

Volume XIX

Behrent's

Performance Warehouse

ORDER ONLINE AT BEHRENTS.COM



Photo by Bob Armbruster



FREE SHIPPING

ON ORDERS \$100 OR MORE. SOME EXCLUSIONS APPLY.

CALL TODAY 877-372-2348 • 845-651-7389



Harry Behrent, President
hbehrent@behrents.com • Extension: 113

Thank you for picking up our 2019 catalog. 2018 was a year of change for Behrent's Performance Warehouse with the launch of our revamped mobile friendly website www.behrents.com, as well as adding new vendors. This helped Behrent's in keeping the throttle down to provide you with everything for your race day.

Behrent's Performance Warehouse strives to provide a superior customer service experience through quality products and competitive pricing. This begins with our knowledgeable sales staff that is always ready to assist you with anything you may need. Our shipping department ensures that your order is packed properly and efficiently. By using both Fed Ex and UPS your order will arrive at your door as quickly as possible using the various shipping options that best suit your needs.

This year's catalog features tons of products from over 100 vendors including new vendors such as Maxima Racing Oils and Racefan. Be sure to visit our website www.behrents.com for the full array of products that we offer. Our website is a great way to find out about everything that is happening here at Behrent's, with links to our social media outlets such as Facebook, Twitter, and Instagram. While on our website, sign up for the Behrent's email blast to get all of the latest industry news such as new product announcements and various promotions that we are running throughout the year.

We appreciate your continued business. Remember, Behrent's offers FREE SHIPPING on all orders over \$100.00 (some restrictions do apply). From all of us at Behrent's, Good luck in the coming race season.



Jeff Behrent, Vice President
jbehrent@behrents.com • Extension: 127

Come Visit Our Booth at:

Northeast Racing Products Show http://northeastracingproducts.com NY State Fair Grounds 581 State Fair Blvd, Syracuse, NY 13209	Motorsports Race Car & Trade Show http://www.motorsporttradeshows.com Greater Philadelphia Expo Center 100 Station Ave, Oaks, PA 19456
PRI Show http://www.performance-racing.com/tradeshows/ Indiana Convention Center 100 S Capitol Ave, Indianapolis, IN 46225	Motorsports Expo https://nysfair.ny.gov/event/motorsports-expo/ NY State Fair Grounds 581 State Fair Blvd, Syracuse, NY 13209

JEFF



Sales Dept.

Our Top Notch sales staff are filled w/racers, NO order takers. They have great knowledge about Oval Track, Drag Race, Hot Rodding, and etc...



Jeff Heotzler's knowledge of racing comes from 30+ years of experience in the sport. He is an expert when it comes to engine and chassis setup. Recently inducted into the Northeast Dirt Modified Hall of Fame. jheotzler@behrents.com • Extension: 120

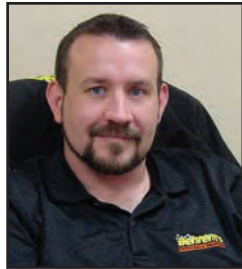

Jon Lynch has over 10+ years of experience in automotive parts. As one of our Sales Managers, Jon has a strong work ethic which helps him strive to make sure our customers get the best care possible. jlynch@behrents.com • Extension: 119

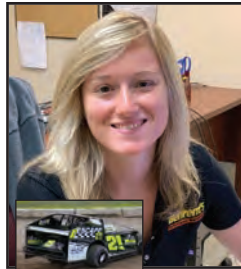

Winter Mead raced a Crate Sportsman at OCSF and Accord Speedway for a number of years. Now she races go karts, motocross, and quads on her time off. Winter is in our sales department. wmead@behrents.com • Extension: 118



Ryan Hill has nearly 10 years of automotive industry experience and a strong passion for dirt racing. Ryan strives to combine his work ethic and love of racing to best assist his customers. rhill@behrents.com • Extension: 117

Behrent's Performance Warehouse

Store Hours:

Mon: 8:30-7:00
 Tue: 8:30-7:00
 Wed: 8:30-5:30
 Thurs: 8:30-5:00
 Fri: 8:30-5:00
 Sat: 9:00-1:00
 Sun: Closed

Controller



Chris Diaz is the controller at Behrent's Performance Warehouse. She handles accounting, inventory control, payroll administration, human resources, and other duties. cdiaz@behrents.com • Extension: 128



Joan Behrent is pictured here with "the kids": Thumper, Flower, Bambi, Daisy, and Teaco. Joan works in accounting. Behind every good man is a good woman...

Art Dept.



Rich Prisco is our Graphic Designer/Multimedia Designer. He manages and designs our catalogs, websites, social media sites like Facebook, Instagram, Twitter, does print ads, trade show posters, and other computer graphic stuff. He also helps out in sales. rprisco@behrents.com • Extension: 130



Behrent's is always looking for good help in our sales staff or shipping department. The right person can receive 401-K, health benefits, and a great working environment.

Behrent's Performance Warehouse

Volume XIX

Shipping Dept.



Garry Sloat raced his DIRT car from '80 to '94. Garry is the head of our shipping department. He takes great pride to make sure our customers get quality service. He is our warehouse manager. gsloat@behrents.com • Extension: 131

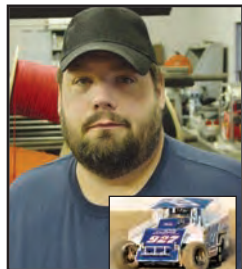

Art Elston used to race this DIRT Sportsman. Art has worked at Behrent's for a number of years and has great racing knowledge. He works in the fabrication shop, rebuilds transmissions, and helps in shipping.

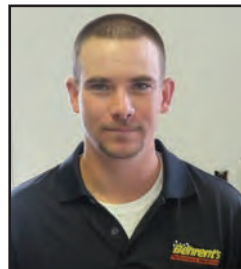

Steven Couser works in our shipping department and also helps out in receiving. When not at work, Steven spends most of his time working on dirt race cars or goes hunting/fishing.

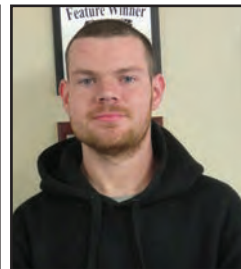

Brendan Butler is a valuable member to the Behrent's shipping department. He helps make sure that the parts you order get shipped out correctly. Brendan works in our shipping department.

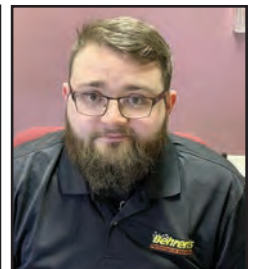

Jesse Babcock is the newest member to the Behrent's team. Jesse is in charge of receiving, inventory control, and helps out in shipping.

Customer Info.

Prices are subject to change without notice. We only accept Visa, Mastercard, and Discover. No C.O.D.'s or checks. For your security we only ship to the billing address. We will accept returns within 30 days of shipping date, and gladly refund the purchase price. Shipping charges are not refundable. We can't accept returns without original invoice. Any part which, in our opinion, appears to be used or mis-handled will not be eligible for exchange or refund. All returned parts must be in clean, resellable condition! We reserve the right to charge up to a 15% restocking fee on returned items. We can't accept returns on custom ordered parts. We can't be responsible for typographical errors. All orders are shipped UPS ground unless otherwise arranged.

NEW PRODUCTS

The Paddock 2 Layer SFI-5



Impact's Paddock suit is the ideal choice for the budget-minded pit crew or driver. Featuring the same excellent fitment and style that Impact is famous for, the Paddock is manufactured from three layers of flame-retardant treated cotton and surpasses the SFI 3.2A/5 standard. The multi-layer quilted construction adds valuable seconds of protection against direct flame and heat transfer while adding durability and comfort. Offered with a boot cut pant leg and available as a one-piece overall or two-piece jacket and pant combo, the Paddock suit is available in sizes ranging from small to 3XL. Colors: Black Only



Paddock 2 Layer Driving Suits Black		
Suit	Jacket	Pants
S.....IMP21100310	IMP211100310	IMP211200310
M.....IMP21100410	IMP211100410	IMP211200410
L.....IMP21100510	IMP211100510	IMP211200510
XL.....IMP21100610	IMP211100610	IMP211200610
XXL.....IMP21100710	IMP211100710	IMP211200710
XXXL.....IMP21100810	IMP211100810	IMP211200810
\$160.00	\$160.00	\$160.00



Revo Carbon

The new REVO CARBON is built with a reinforced Carbon Composite Shell engineered specifically for the Snell SA15 specs. This Carbon Composite Shell is coated with a deep gloss clear for a brilliant shine. Across the chinbar and crown of the helmet, you will see the polished aluminum grill guards of the Siphon12 Vent Network, a system of 6 intake ports, 2 forehead ports and 4, rearward exhaust ports designed to move heated out of the helmet. The bottom of the Helmet is more contoured to today's helmet restraint devices and is lined with a rubber gasket made for easy use and cleaning. **Revo Carbon.....GFO3411BK.....\$474.99**



55 Series Pro Street Drag 18°



The 55 Series seat has the same fit and feel as the 41 Series, slight changes to bottom allows this version to be mounted in a wide range of lay-back angle without raising center of gravity in the race car. Use of .100" thick alum throughout the seat has reduced weight up to 1/2 pound, (varies by size).

Seat	Cloth Cover
15".....KIR55150	\$151.35
16".....KIR55160	\$151.35
17".....KIR55170	\$151.35
18.5".....KIR55185	\$166.48
20".....KIR55200	\$166.48
	KIR5515011 \$117.65
	KIR5516011 \$117.65
	KIR5517011 \$117.65
	KIR5518511 \$128.52
	KIR5520011 \$128.52



Tear-Offs
RAC10209C

Devil Ray

Snell SA 2015 Certified. The Devil Ray Carbon has an exceptionally lightweight carbon shell, that weighs in at 2.9 lbs. for size Medium. Radio communications available. Top air and side pipe options available, \$150 additional charge (call to order). Includes helmet bag. NEW Composite Devil Ray weighs a little more than carbon but if you are looking for an incredible value, the composite Devil Ray is for you. Sizes XS-XXL. Replacement Shields: SIM84300A: Clear
Standard.....SIM683.....**\$399.95**



Helmet Dryer

Newest antibacterial multi-equipment dryer circulates air in a temp controlled environment to safely dry helmets, gloves and footwear. The truth is cheek pads and liners degrade over time from perspiration and bacteria. Keep your equipment in peak condition longer by stopping mold and mildew before it starts. Temp and timer settings. Simple design easily accommodates multiple styles and sizes. Anti-bacterial, eliminates odors and controls bacteria growth. Dual dryer ports. 110 volt. Displays Celsius or Fahrenheit. **SIM97100...\$129.93**



GF7 Side Air

2015 Helmet with a sleek new design from G-Force Racing, the GF7 Full Face has provided a new benchmark in quality, functionality and style. From the outside in you will notice the difference. The outer contact shell is made from a low density, Z38 lightweight composite blend. The shell is then coated with deep rich white gloss paint and finished with a protective clear coat outer layer. The rear of the helmet is accented with double ridge lines that add both style and strength to the GF7 Full Face's shell. **GF7 Side Air.....GFO3127WH.....\$199.99**



Composite Race Fans

It features a universal center hub RACE-FAN made from 6061-T6 Alum and composite blades for a significant decrease in weight over traditional steel fans. Our blades are manufactured using extremely durable high-impact and high-temp fiber reinforced Zytel.

6 Blade Race Fans	
17".....RFN64-1700-006	\$.360.00
19".....RFN64-1900-006	\$.360.00
4 Blade Race Fans	
17".....RFN64-1700-004	\$.265.00
19".....RFN64-1900-004	\$.265.00
3 Blade Race Fans	
17".....RFN64-1700-003	\$.217.50
19".....RFN64-1900-003	\$.217.50
2 Blade Race Fans	
17".....RFN64-1700-002	\$.170.00
19".....RFN64-1900-002	\$.170.00
Blade Only	
17".....RFN62-1700-000	\$.40.00
19".....RFN62-1900-000	\$.40.00

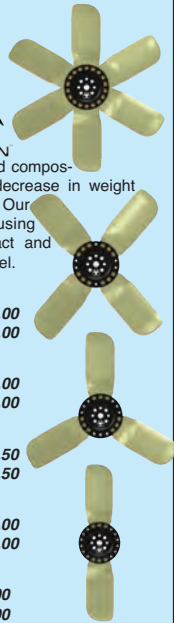

Sprintcar / Dirt Late Model Concept specific Aluminum structure

New enhanced vibration absorption foam construction for better feel during the race. Black Anodized Spokes with Secondary Post Machining (SPM). New MPI signature style while providing a weight reduction. Included in all MPI-D2-15: New lightweight MPI-A-CP-D2. Centerpad with reduced height and weight, MPI center logo in Black & fluorescent Orange colors.
• Dia: 15 inches • Weight: 2 lbs
• Dish depth: 0 inches
• Spoke: 3 slotted spokes
More MPI Products are on page 67.
MPI-D2-15...\$249.00



Sprint Triple Pass

19.75" H x 20.25" W x 3" Thickness
These aluminum with natural finish tri pass radiators are specifically designed for 305 engines in sprint cars and are made to run 50'-70' cooler than std double pass radiators. Requires #10 o-ring boss fittings & small dia 1" radiator cap shown below. Uses the small 1" cap. Inlet/Outlet: Upper Left/Lower Right. Flow Quantity:2
BSC400-49935.....\$220.46

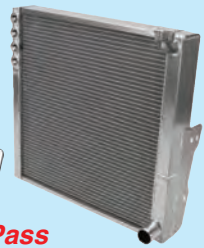

Hubs

6061-T6 Aluminum. 3/8" & 5/16". Made in the USA. Patent Pending.

17".....RFN60-5000-750	\$.75.00
19".....RFN60-5000-625	\$.75.00

Hardware

Hardware Kit for 1 Blade ...RFN61-1000-000	\$.75.00
1/4" Nas Bolt X 1/2" Long...RFN12-0408-000	\$.15.00
1/4" Jet Nut.....RFN18-0250-000	\$.09.00
1/4" Thin Washer.....RFN22-0250-000	\$.07.00



FREE SHIPPING ON ORDERS \$100 OR MORE. SOME EXCLUSIONS APPLY.

**"HOT SHOE!
A Checkered
Past: My Story"**
By Gary Balough
with Bones Bourcier

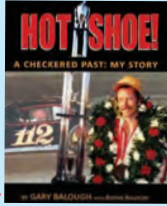

"Hot Shoe! A Checkered Past: My Story" is the autobiography of infamous stock car racer, Gary Balough. Balough is known for being one of the country's winningest drivers on dirt and asphalt short tracks, though his career would take an unexpected turn just as it began to peak. "Hot Shoe" not only covers Balough's illustrious career on the track, but also his fall from grace after becoming involved in organized crime.
BSC-GB73...\$29.99



**Air Mover Fan
900 CFM 115V**



The Mr Gasket Airmover fan features an advanced blade design that produces a high air-flow and quiet operation. The unique shape of the fan housing allows multiple mounting positions to provide ventilation and cooling where it is needed. Ideal for use in the shop, trailer, or at the race track.
• High Volume Airflow - 900 CFM • Built-in Handle
• Advanced Blade Design - High Output/Quiet
• Uses Only 2 Amps when Running
• 15' Long Cord • 1/4 HP Motor • 16.5 Lbs
• 12 Amp Power Outlet - Allows Use of Tools, Lights, or Daisy Chain Operation of Multiple Fans
• Overall Dimensions: 19.5" L x 17.5" W x 8.6" T
• Ideal for Cooling Down Race Engines & Trans
MRG3320G\$219.95

**65 Series Adjustable
Road Race Seat**



New versatile Adjustable Road Race Seat can be used for Kit Cars, Club Racing and even Drag Racing. Vertically adjustable 2-1/2" for customization. Bottom designed for multiple layback angles. (18 to 23 degrees). Extra padding throughout black air knit cover for added comfort. Cover designed to accommodate leg supports. (02100-02200). Uses 99212 (rear) & 99214 (bottom) seat mounts.



Seat and Cover
15".....KIR65150KIT \$439.00
16".....KIR65160KIT \$439.00
17".....KIR65170KIT \$439.00
18-1/2" ..KIR65185KIT \$465.00



Behrent's Racing Black Shirts

Three yarns form the perfect easy going look. 4.5-ounce, 50/25/25 poly/combed ring spun combed cotton/rayon, 32 singles. Tear-away label. 1X1 rib knit neck. Shoulder to shoulder taping.
Please note: This product is transitioning from woven labels to tear-away labels. Your order may contain a combination of both labels. Tri-Blend fabric infuses each garment with unique character. Please allow for slight color variations. Due to the heat sensitivity of tri-blend fabrics, special care must be taken throughout the printing process. Consult your decorator or ink supplier for best printing practices. Colors Black or White.



CARE INSTRUCTIONS: Machine wash cold with like colors. Only non-chlorine bleach. Tumble dry low. Warm iron if necessary.
*Larger sizes are slightly higher.
BSC011...\$15.95*



**Behrent's Racing
Black Hoodies**



8-ounce, 50/50 cotton/poly. Double-needle stitching at waistband and cuffs. Double-lined hood with dyed-to-match drawcord. 1x1 rib knit cuffs and waistband with spandex front pouch pocket. Due to the nature of 50/50 cotton/poly neon fabrics, special care must be.
*Larger sizes are slightly higher.
BSC012...\$25.95*

**RS Series
Engine Oils**



It is a 100% synthetic triple ester based race-grade engine oil. Tech advanced formula contains special anti-wear/extreme pressure additives to protect critical engine components from extreme loads & peak temps generated by high-perf engines. Delivers increased hp, reduces wear on bearings, cams, lifters, crankshafts & extends engine life. High Zinc/Phosphorous formula engineered for use in flat tappet & roller element engines.
0W-10 - 32 oz QuartsMAX39-13901\$13.95
0W-20 - 32 oz QuartsMAX39-14901\$13.95
5W-20 - 32 oz QuartsMAX39-04901\$13.95
5W-30 - 32 oz QuartsMAX39-91901\$13.95
10W-30 - 32 oz QuartsMAX39-01901\$13.95
10W-40 - 32 oz QuartsMAX39-16901\$13.95
10W-50 - 32 oz QuartsMAX39-32901\$13.95
5W-30 - 128 oz Gallons.....MAX39-919128...\$53.95
10W-30 - 128 oz Gallons...MAX39-019128...\$53.95
10W-40 - 128 oz Gallons...MAX39-169128...\$53.95
15W-50 - 128 oz Gallons...MAX39-329128...\$53.95

PANELfast

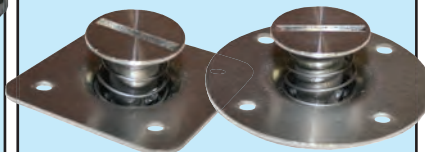

Plates with Self Eject Buttons

1-3/4" Round Alum. Plate w/ 7/16" Self Eject .500 Grip
PANEA6500-8450A\$4.50
1-3/4" Round Alum. Plate w/ 7/16" Self Eject .550 Grip
PANEA6550-8450A\$4.50
1/2" Square Steel Plate w/ Self Eject .500 Grip
PANEA6500-8462\$4.50
1/2" Square Steel Plate w/ Self Eject .550 Grip
PANEA6550-8462\$4.50



Fan Shroud



19" x 27" -31" for Radiator
Adjustable Fan Shroud
Easy to trim for custom fit.
DIR2200FS.....\$129.99



Teo Side Oil Cooler Mount

TEOT059...\$107.25



Behrent's Black Flex Fit Hat

Mid-profile cotton twill cap is structured fitted. Made from cotton/spandex.
S/M.....BSC0520.....\$19.95
L/XL.....BSC0521.....\$19.95

Flex Fit



Behrent's Black Velcro Back Hat

Six-panel twill cap with structured velcro closure, 100% cotton twill.
VelcroBSC0511\$14.95

**Adjustable
Velcro**



**Behrent's Charcoal Velcro Back Hat
Unstructured**

Garment washed cap with unstructured velcro closure, made from cotton.
VelcroBSC0510.....\$15.95

**Adjustable
Velcro**



**SFI 3.3/5
tagged**



Wheeler Glove SFI 3.3/5 (2 Layer)

Certified to SFI 3.3/5 standard, the aggressively styled Wheeler Racing Glove features minimal seam construction and optimized levels of grip via a newly designed leather palm and fingers. Fire-resistant aramid fiber main construction Mid length gauntlet with convenient pull tab.
• Color: Black or Red. Sizes S-XL.
SIMWG...\$149.95

HELMETS

SIMPSON

Voyager 2

Tear-Offs
RAC10209C

Snell SA 2015 Rated The Voyager 2 is a redesign for one of our customer favorites, featuring our largest eye port for excellent field of vision. The helmet interior included contrast stitching and branding. Frontal head restraint ready. Radio communications may be added. Colors: White, gloss black +30 matte black. Recommended for: Multi-use. Circle track, Dirt track, Drag, Karting, Off Road and Road Racing. Sizes XS-L.



SIM610.....\$369.95

Tear-Offs
RAC10209C

Devil Ray

Snell SA 2015 Certified. The Devil Ray Carbon has an exceptionally light-weight carbon shell, that weighs in at 2.9 lbs. for size Medium. Radio communications available. Top air and side pipe options available, \$150 additional charge (call to order). Includes helmet bag. NEW Composite Devil Ray weighs a little more than carbon but if you are looking for an incredible value, the composite Devil Ray is for you. Sizes XS-XXL. Replacement Shields: SIM84300A: Clear



Standard.....SIM683.....\$399.95
Carbon Fiber.....SIM683C.....\$879.95

RACING OPTICS

Tear Offs are on Page 8!

Tear-Offs
RAC10210C

Venator

The Simpson Venator's plush interior offers optional placement of Simpson's ear cup speakers. Plush interior with Simpson branding on cheeks. Gel ear cups with optional padded ear inserts. Frontal Head restraint ready. Recommended for: Multi-use helmet. Circle track, Dirt track, Drag, Karting, Off Road and Road Racing. Sizes XS-XXL. Replacement Shields: SIM84500: Clear. SIM685....\$679.95



Venator CF

FIA 8859-2015, Snell SA 2015 Certified. The Venator helmet features an exceptionally strong outer shell and an energy absorbent liner. Plush interior with Simpson branded cheek pads. Gel ear cups with optional padded ear inserts. Radio Communications available. Included padded helmet bag. Frontal Head Restraint ready. Recommended for: Multi-use helmet. Circle track, Dirt Track, Drag, Karting, Off Road & Road Racing. Sizes XS-XXL. Replacement Shields: SIM84500: Clear. SIM685C....\$999.95



Tear-Offs
RAC10210C

Helmet Sizing Chart

INCHES	20	21	22	23	24	25
CENTIMETERS	51	52	53	54	55	56
HAT SIZE	6 1/8 - 6 1/4	6 1/2 - 7	7 1/8 - 7 1/4	7 1/2 - 7 3/4	7 3/4 - 7 7/8	7 7/8 - 8
HELMET	XS	SM	MD	LG	XL	XXL

SIMPSON

To work it's best, a helmet must fit properly. Measure around your head, just above your ears and eyebrow.

Bandits: Drag Racing

Tear-Offs
RAC10204C

Bandit

Snell SA 2015 rated. Classic flag-ship Bandit design remains true to Simpson's heritage for distinct style and helmets you can trust to do their job. Colors: White, Gloss Black +30 Matte black. Recommended for: Multi-use helmet. Circle track, dirt track, Drag, Karting, Off Road and Road Racing. Sizes: XS-XXL. Replacement Shields: SIM89400A. SIM620.....\$449.95



Tear-Offs
RAC10204C

Carbon Bandit

Snell SA 2015 Certified. Classic Bandit flag ship design, improved aerodynamics through design innovation. 1/3 lbs. lighter than composite Bandit helmet. Radio communications available. Side pipe option available. Includes helmet bag. Frontal Head Restraint ready. Recommended for: Multi-use helmet. Circle track, Dirt track, Drag, Karting, Off Road and Road Racing. Sizes: XS-XXL. Replacement Shields: SIM89400A: Clear. SIM620C.....\$879.95



Tear-Offs
RAC10204C

Speedway RX

Manufactured in the USA. Snell SA2015. Classic "RX" styling with defined Wave Eliminators for increased aerodynamics. Radio communications may be added. Frontal head restraint ready. Colors: white, gloss black. +30 matte black, blue, red, safety orange, silver and pearl white. Recommended for: Multi-use helmet. Circle track, dirt track, Drag, Karting, Off Road and Road Racing. Sizes 7-1/8 - 7-3/4. Replacement Shields: SIM1020-12: Clear. SIM651.....\$669.95



Tear-Offs
RAC10204C

Super Bandit

Manufactured in the USA Snell SA 2015 rated. Classic flag-ship Bandit design remains true to Simpson's heritage for distinct style and helmets you can trust to do their job. Colors: white, gloss black. +30 matte black, blue, red, safety orange, silver and pearl white. Recommended for: Multi-use helmet. Circle track, Dirt track, Drag, Karting, Off Road and Road Racing. Sizes 7-1/8 - 7-3/4. Replacement Shields: SIM89400A: Clear. SIM621.....\$569.95



Tear-Offs
RAC10204C

Drag Bandit

Manufactured in the USA. Snell SA 2015 rated. Classic flag-ship Bandit design remains true to Simpson's heritage for distinct style and helmets you can trust to do their job. Frontal Head Restraint Ready. Drag Sock is SFI.10 rated. Colors: white, gloss black. +30 matte black, blue, red, safety orange, silver and pearl white. Recommended for: Drag Racing. Sizes 7-1/8 - 7-3/4. Replacement Shields: SIM89400A. SIM622...\$779.95



Tear-Offs
RAC10204C

Diamondback

Manufactured in the USA. Snell SA 2015 Rated. Defined "Wave Eliminators" increase functionality from an aerodynamics aspect. Recessed eye port offers a 100% shield seal. Frontal Head Restraint Ready. Radio communications available. Side pipe air option available. Recommended for: Multi-use helmet. Circle track, dirt track, Drag, Karting, Off Road and Road Racing. Sizes 7-1/8 - 7-3/4. Replacement Shields: SIM1020-12: Clear. Standard.....SIM629.....\$699.95. Carbon Fiber.....SIM629C...\$1,599.95



Speedway Shark

Manufactured in the USA Snell SA 2015 Certified

The Speedway Shark helmet has defined wave eliminators that increase functionality from an aerodynamics aspect. Radio Communications available. Frontal head restraint ready - Includes helmet bag. Colors: white, gloss black, +30 matte black, blue, red, safety orange, silver and pearl white. Recommended for: Multi-use helmet. Dirt track, Circle Track, Drag, Karting, Off Road and Road Racing. Sizes 7-1/8 - 7-3/4.

Replacement Shields: SIM1010-17
SIM670.....**\$869.95**



Junior Speedway Shark

Manufactured in the USA Snell SA 2015 Certified. The Jr. Speedway Shark is proportionately sized for younger racers. Frontal head restraint ready. Radio communications available. Colors: White, Gloss black, +30 matte black, blue, red, safety orange, silver and pearl white. Recommended for: Circle track, Dirt track, Drag & Karting. Shields: SIMJ88600: Clear

Colors: White, Gloss black, +30 matte black, blue, red, safety orange, silver and pearl white. Recommended for: Circle track, Dirt track, Drag & Karting. Shields: SIMJ88600: Clear
SIM178.....**\$499.95**

JR Helmet Sizing Chart

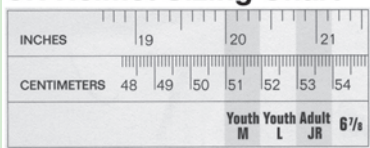

EV1 Vudo

Manufactured in the USA. Snell SA2015 Certified. The Vudo EV1 features a chin bar that offers excellent coverage. Shield pivot system opens and closes with ease. A recessed eye port offers 100% shield seal. Radio communications available. Includes a helmet bag. Colors: white, gloss black, +30 matte black, blue, red, safety orange, silver and pearl white. Recommended for: Multi Use: Stock Car, Dirt Track, Off Road and Road Racing. Sizes 7-1/8 - 7-3/4. Replacement Shields: SIM1010-17: Clear
SIM663...**\$869.95**



Carbon EV1 Vudo

Snell SA 2015 helmets meet Snell's latest and most stringent safety standards. In addition to the strict testing for high impact crashes that Snell certified helmets are subjected to, new tougher requirements have been added for Snell SA2015 certification that also include low velocity and low lateral testing. Additionally, SA 2015 helmets must now be equipped with FIA 8858-2010 compliant M6 terminal mounts for frontal head restraints. A helmet that is Snell SA2015 has passed "Low Velocity" impact testing. Sizes: 7-1/8- 7-5/8. Replacement Shields: SIM1010-17: Clear
SIM663C....**\$1,599.95**



OTW Shorty

The Shorty open faced half helmet is DOT rated and includes a 4-way adjustable strap system and a glare reducing visor. It works well for motorcyclists who prefer the minimum helmet and is popular for sport street bike riders and cruisers. For optimal safety, Simpson recommends that you consider a full face helmet. Color: Black or White. Sizes: XS-XL
SIM143....**\$99.95**



Fresh Air Helmets



Air Inforcer Shark

Made in the USA Snell 2015 rated. Design features include a stylish top cap designed for better pipe placement and a low profile for multiple roof/driver height. Recessed eye port offers a 100% shield seal - Radio communications available. Includes helmet bag. Frontal head restraint ready. Colors: white, gloss black, +30 matte black, blue, red, safety orange, silver and pearl white. Recommended for: Multi-use helmet. Circle track, Dirt track, Off Road and Road Racing. Sizes: 7-1/8 - 7-3/4
Replacement Shields: SIM1010-17: Clear
SIM677**\$899.95**



Air Inforcer Vudo

Manufactured in the USA Snell SA2015 Certified. Design features include a stylish top cap with molded in hose adapter for better air flow and strength. Recessed eye port with 100% shield seal. Frontal head restraint ready. Radio communications are available -Includes a helmet bag. Colors: white, gloss black, +30 matte black, blue, red, safety orange, silver and pearl white. Recommended for: Multi-use helmet. Circle Track, Dirt Track, Off Road and Road Racing. Sizes: 7-1/8 - 7-3/4.
Replacement Shields: SIM1010-17: Clear
SIM662**\$899.95**



Carbon Fiber Air Inforcer Vudo

Manufactured in the USA Snell SA 2015 Certified. Made from exceptionally lightweight, Auto Clave Molded Carbon Fiber. 1/3 lbs. lighter than composite Air Inforcer Vudo. Design features include a stylish top cap with a molded in hose adapter for better air flow and strength. Recessed eye port offers a 100% shield seal. Radio communications are available. Includes padded helmet bag. Frontal Head Restraint ready. Recommended for: Multi-use helmet. Circle track, Dirt track, Drag, Karting, Off Road and Road Racing. Sizes: 7-1/8 - 7-3/4.
Replacement Shields: SIM1010-17: Clear
SIM662C**\$1,699.95**



If you need a new shield and are not sure what helmet it is, just check out the top left side of the shield. It is inscribed right in the shield.

Snell 2005 & Earlier

	Clear	Smoke	Iridium	Amber	Silver Mirror
Voyager	88200A \$49.95	88201A \$49.95	88203 \$69.95	88204A \$59.95	88206A \$69.95
New SW Voyager, Sidepro Voyager	88300A	88301A	88303	88304A	88306A
SW Shark, VUDO, Air Inforcer Shark	88400A	88401A	88402	88403A	
Spdvy Shark, Valor, Sup Shark, Invader	88600A	88601A	88602	88603A	88606A
RX	89200A	89201A	89203	89204A	89206A
Bandit, Super Bandit, Diamond Back	89400A	89401A	89402	89403A	89406A
Jr Speedway Shark	J88600	J88601	J88602	J88603	

Snell 2010 & Newer

	\$59.95	\$59.95	\$79.95	\$69.95	\$79.95
Shark & Vudo	1010-17	1011-17	1013-17	1012-17	1014-17
XBandit, Diamondback, & RX	1020-12	1021-12	1023-12	1022-12	1024-12
SW Voyager, Voyager Evolution	1030-12	1031-12	1033-12	1032-12	1034-12
Bandit, Super Bandit	89400A	89401A	89402	89403A	89406A
Devil Ray	84300A	84301A	84303A	84304A	84306A*...\$69.95*
Venator	84500A	84501A	84503A	84502A	84504A
Voyager 2	88800A	88801A	88803A	88802A	88804A

Pivot Kits

For 101, 102, & 103 (2010 Snells)
Voyager 2 SeriesSIM99014 **\$.12.95**
For Voyager, Model (410).....SIM99022 **\$.12.95**
For Devil RaySIM99013 **\$.12.95**
For Carbon BanditSIM99016 **\$.12.95**
For Bandit and Super Bandit.....SIM99002 **\$.12.95**
Rubber Kit.....SIM99005 **\$.12.00**
For Venator.....SIM99018 **\$.12.95**



RACING OPTICS

Aluminum Posts

Anodized, CNC machined mounting posts. The smooth edges help to provide snag free and tearless removal of tearoff layer. Comes with hardware.
RAC9900...**\$12.95**



Acrysol Shield Cleaner

Acrysol Shield Cleaner is the only cleaner that should be used on Simpson Venator helmet shields and all Stilo helmet shields. It should be applied using a standard paper towel. Micro Fiber cloths should not be used. This product also works for cleaning all other Simpson shields without damaging the anti-fog, anti-scratch, or colored coatings (mirror, iridium). Will not damage shield coatings. Safe to use on most painted or plastic surfaces. Should be used with a regular paper towel and not a micro fiber cloth. No lingering odor. No film residue.

Directions for use:

1. Spray Acrysol on a clean paper towel to saturate.
2. Wipe shield with saturated paper towel to clean.
3. Wipe dry with clean paper towel.

SIMYA0640**\$19.95**



Clear Tear-Offs 10 Laminated

(3 Stacks per Sleeve)..\$29.95

It features our patented laminated tearoff technology, is a 2 mil thick, 10-layer tearoff stack that is great for all dirt racing applications. Each sleeve contains 3 stacks of 10 tearoffs. For a total of 30 tearoffs per sleeve. Optical grade Mylar tearoffs laminated into stacks increase visibility by allowing more light transmission by reducing the amount of reflected light tearoff between layers.

CLEAR



Racer Optics Tear Offs

- RAC10201C...11 1/2"....straight.....Simpson Voyager/Side Pro Elite/ universal straight
- RAC10203C...11 1/2"....banana.....Simpson Matrix/ Jr Shark/ HJC auto racing helmet/ OMP/ Zamp pre 2013
- RAC10204C...11 1/2"....nose notch.....Simpson RX/Super Bandit/Diamond Back/Raider
- RAC10205C...12 3/8"....banana.....Bell GTX/Vortex/ BR-1/ M4/ K-1/ Sport / 276/ 281/ 288 shield/ Pyrotek G-Force/ Racequip/ RCI/ Champion
- RAC10206C...11 1/2"....banana.....Bell Dominator.3/ GTX.3/ GP.3/ HP.3 with SE03/SE05 shield
- RAC10208C...12 1/8"....banana.....Bell Dominator.2/GTX.2/ GP.2/ GP.2 Youth/ Star GP/ Star Infusion/ M.8/287 shield/ Zamp FS.2/ RJS
- RAC10209C...12 3/4"....banana.....Simpson Shark/ VUDDO/ Invader/ Valor/ Sting Ray/ Devil Ray/ K-10/ EV1 Voy Evolution/ Voyager 2/ Impact Air Draft/ Super Sport/ Spider/ EuroSport /1320
- RAC10210C...13".....banana.....Simpson Venator, Sparco RF-5W
- RAC10211C...12 1/4"....nose notch.....Bell Vador/ RaceQuip Vesta 15
- RAC10216C...11 1/2"....vent cut-outs.....Arai with vent cut-outs pre 2011
- RAC10217C...11 1/2"....no cut outs.....Arai GP-5W/ Shoei bike X-11/ Bell Star bike/ HJC bike AR-10/ Stand 21
- RAC10218C...12 3/4"....no cut outs.....Arai GP-6/ GP-6S/ GP-6PED/ SK-6
- RAC10230C...11 7/8"....banana.....Impact Vapor/Air Vapor/Charger/Super Charger- Scorpion EXO-R2000
- RAC10231C...11 1/2"....nose notch.....Impact Champ/Nitro/Super Cyclone
- RAC10235C...12 7/8"....banana.....Bell HP7/ RS7 with SE07 shield and Zylon Visor strip- small tabs
- RAC10237C...12 7/8"....banana.....Bell RS7/ HP7 with SE07 shield/ large tabs for dirt racing
- RAC10245C...12 3/4"....no cut outs.....Arai GP-6/ GP-6S with F1 Zylon visor strip
- RAC10252C...12".....banana.....Stilo ST5 w/ large tabs
- RAC10258C...11 1/4"....straight.....Stilo ST4
- RAC10259C...12".....banana.....Stilo ST5 w/ small tabs
- RAC10285C...12 1/2"....vent cut-outs.....Arai Corsair X/ RX-7V
- RAC10287C...12 1/4"....banana.....Bell Star 2016

RACING OPTICS

Aluminum Posts

Use to replace lost posts, or upgrade other helmets
Tear-Off posts, pair w/screws.
RAC9900..\$12.95



EZ Tear Shield Mounted

It provides a shield for the folded tearoffs to keep you from grabbing them by accident. It protects the folded tabs and guides your hand to the top tearoff so you can get the full benefit of every single tearoff and ultimately keep your vision clear so you can focus on the racing and not fumbling with tearoffs. It is universal and attaches between the lens and the tearoff post and adjusts to accommodate the tearoff tabs on all brands of helmets and tearoffs.



- PULEZTS101BK.....Black.....\$19.99
- PULEZTS101W.....White.....\$19.99

Helmet Shield Protector

Extend the life of your expensive shield! No more scratches, no more firt getting under your SpeedStack7. Exclusive PerimeterSeal adhesively mounts to your visor under your Laminated Tearoffs. Seals out dirt, dust, moisture, fogging, and eliminates scratches. Universal shape fits any flat racing shield with no posts required.

Shield Protectors

Amber.....RAC7221AP3.....\$29.95
Instantly turns your clear visor to high contrast amber, 7 Laminated layers (21 total layers per sleeve)



Smoke.....RAC7221SP3.....\$29.95
Instantly turns your clear visor to smoke, 7 Laminated layers (21 total layers per sleeve)

Helmet Dryer

Newest antibacterial multi-equipment dryer circulates air in a temp controlled environment to safely dry helmets, gloves & footwear. The truth is cheek pads and liners degrade over time from perspiration and bacteria. Keep your equipment in peak condition longer by stopping mold and mildew before it starts. • Temp & timer settings • Simple design easily accommodates multiple styles & sizes • Anti-bacterial, eliminates odors and controls bacteria growth • Dual dryer ports • 110 volt • Displays Celsius or Fahrenheit
SIM97100..\$129.93



Mini Helmet Air System

Self-contained, 12-volt fan with reusable filter moves approx 40-60 CFM of air depending on system voltage. An RF connector allows easy unrestricted helmet removal. A 14" wire is permanently attached to the fan and accepts the 24" pigtail (included). Pigtail has simple red (+) & black (-) wire hook-ups.
Mini Helmet Air System...ALL13012...\$79.99



Tornado Helmet Fan

All Billet Construction. Totally Rebuildable. Multi Position Mount for 1-1/4" Tubing. Bolts up in only a few minutes. No Drilling or Brackets. Stainless Steel Hardware. Weather tight quick disconnect plug. 7 foot Lead wires. Helmet Hose included.
BRP9153..\$181.44



Replacement Hose

BSC80900.....\$25.95

Heavy Duty On/Off Switch w/Rubber Cover

QUA360-1210...\$8.95



"Storm Series" Helmet Blowers

Increased CFM from the standard 3" version. Helps control fogging for drivers with different breathing patterns. Standard 1-1/4" mounts or optional deck / dzus mount. Larger filter and standard hose all included.
BRP9300...\$216.62



Replacement Wire Harness for BRP9300

BRP93001..\$33.42



Replacement Filter

LUBER-FINER
Luber-finer air filters capture harmful particles that can damage expensive engines. Cleaner air can help increase engine efficiency and lead to greater fleet uptime. Remove 99.99%* of airborne contaminants. Meet form, fit and function characteristics for the application.
Air Filter for Parker Pumper...LUBLAF-73...\$16.43



TRANSPONDERS

X2 Transponder Car

The more you know, the faster you go - and that is exactly why we bring you the X2 Transponder for car racing. X2 will guide you to faster laps, as it offers insights into your performance. You can see, analyze and share your training and race results through your personal MYLAPS account. With the additional Direct Power upgrade you can connect your transponder to your car's battery.



X2 Transponder & X2 Transponder Holder. Comes standard as rechargeable, Direct Power upgrade available.

X2 RaceKey. The X2 RaceKey is here to help you manage your subscription and charge your transponder.

X2 RaceKey Mt. The X2 RaceKey Mount comes with the Direct Power upgrade. It helps you mount your RaceKey onto your dashboard and connect it to your X2 Transponder.

Cabling USB cable, 12V cable & CAN cable (Direct Power only). Introducing the X2 RaceKey. New with X2 is the X2 RaceKey. The RaceKey helps you activate your transponder and manage your subscription. When you use the transponder as a rechargeable one, the X2 RaceKey is used to charge it. X2 features supercharging; it will fully charge in only 4 hours. With the Direct Power upgrade, the LED lights on the RaceKey show various notifications such as battery and subscription statuses. X2 Transponders come with a subscription for 1, 2 or 5 years. When the subscription ends, you can renew it with another period: choose the subscription that fits your racing career best.

Transponder Holder (Red)

Holder Only.....AMBX260-HOLDER.....\$7.00

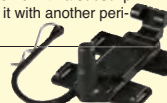

X2 Rechargeable Unit w/Subscription
2 Year Subscription.....AMB10R602...\$239.25

X2 Transponder Wired Unit w/Subscription
2 Year Subscription.....AMB10R612...\$283.18

Is Your Subscription Expired?
1, 2, and 5 Year Renewals Available!

X2 Rechargeable Subscriptions
1 Year Subscription.....AMB11R601
2 Year Subscription.....AMB11R602
5 Year Subscription.....AMB11R605

X2 Direct Wired Subscriptions
1 Year Subscription.....AMB11R611
2 Year Subscription.....AMB11R612
5 Year Subscription.....AMB11R615

Transponder Holder

The mount you need to securely install your Car or Kart X2 Transponder onto your vehicle.

Holder Only...AMBX2-HOLDER...\$7.10

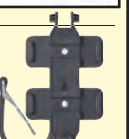

NOMEX UNDERWEAR

Memory Fit Nomex Underwear NEW

SFI 3.3, Memory fit fire retardant underwear for racers. Simpson's unique memory fit fabric becomes softer with each washing and will quickly become your favorite underwear for added race protection.

- SFI 3.3 Certified • Made in the USA
- Nomex blend provides added fire protection
- Anti-microbial treated
- No bulk, unique memory stretch provides built in comfort, while retaining shape
- Contrast stretch stitching for definition

TopSIM20123\$119.95
BottomSIM20124\$119.95



Memory Fit Nomex Head Socks NEW

SFI 3.3 Certified. Made in the USA. Nomex blend provides added fire protection. Anti-microbial treated. No bulk, unique memory stretch provides built in comfort, while retaining shape. Contrast stretch stitching for definition.

SingleSIM23050\$79.95
DualSIM23051\$79.95



Carbon-X Underwear

CarbonX Ultimate Underwear is made from double jersey interlock knit comprised of a patented blend of high-performance fibers. It is inherently flame resistant, will not burn, melt, or ignite when subjected to direct flame.

- Designed to deliver the ultimate in base layer thermal protection
- TPP rating of 13 cal/cm2 and zero seconds after flame
- LW, patented blend of high performance fibers
- Double jersey interlock knit
- Long or short sleeve crew neck top
- Colors: Black only • Size: S - XXL (XXL Available with 15% Upcharge \$114.95)

TopSIM20600\$99.95
BottomSIM20601\$99.95



TOP
SIM20600

BOTTOM
SIM20601



Carbon-X Socks

CarbonX socks are knitted from patented CarbonX yarn and flame-resistant super washed merino wool. Socks feature reinforced tow and heel and a cushioned insole.

- 19" Length • Colors: Black only
- One Size Fits All

SIM23029C..\$42.95

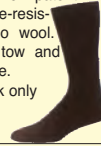

Carbon-X Head Socks

CarbonX Ultimate Underwear is made from double jersey interlock knit comprised of a patented blend of high-performance fibers. It is inherently flame resistant, will not burn, melt, or ignite when subjected to direct flame. • Colors: Black only

Single EyeportSIM23000C\$76.70
Dual EyeportSIM23003C\$76.50



Carbon-X Helmet Skirt

It is made from double jersey interlock knit comprised of a patented blend of high-performance fibers. It is inherently flame resistant, will not burn, melt, or ignite when subjected to direct flame. Colors: Black only

SIM23012C..\$99.95



Ladies Nomex Sports Bra

This comfortable tank style sports bra provides ladies with a safe alternative to unisex undergarments. Underwire, hooks and fabrics in conventional bras have no place on the race track, and are dangerous to race in. Proper support and fire protection is available. The ample design of our sports bra will give you the confidence you need to unzip that suit when you need to cool off without worrying about revealing too much skin.

- Made of fire retardant CarbonX® soft knit, SFI 3.3 approved
- Soft knit eliminates chaffing
- Color: Graphite Gray



SmallSIM20606S ...\$79.95 Large....SIM20606L.....\$79.95
Medium SIM20606M....\$79.95 X-Large SIM20606X ...\$79.95



Neck Support

Reduces neck fatigue for any racer. Removable knit Nomex sleeve. One size with adjustable speedfit fasteners. SFI tag included, SFI 3.3 approved. Black, Blue, and Red

SIM23022.....\$29.95

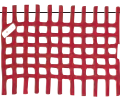

Window Nets

24" x 24" square or 18" x 24" rectangle. Red, Blue, Black

Square NetSIM36003 ..\$99.95
Rectangular Net ...SIM36002 ..\$99.95



Reverse Stitch Shift Boot Cover SFI 48.1

This cover is excellent flame protection...SIM36012..\$79.95



Arm Restraints

A must for Sprint, Midget and Off Road racing. Features padded arm bands & steel hardware. Easy release allows quick entry & exit from driver's compartment. Meets SFI 3.3. Black, Blue, & Red.

SeparateSIM36000\$39.95
JuniorSIM3600J\$34.95
Y-StrapsSIM36001\$44.95



Sprint Window Nets

1" webbing with quick release buckle. Midget/Sprint...SIM36005....\$99.95
Champ Car.....SIM36006.....\$99.95

Helmet Restraint

Fatigue reducing helmet strap. Quick attachment and adjustment. Durable steel hardware, helmet "D-ring" installation. Colors: Black, Blue, Red

SIM36007(color).....\$14.95

JB Cage Net

1" webbing with quick release buckle. Designed for use in conjunction with window net. Do not use separately!

SIM36020 BK...\$69.95



Harness Pads

Attaches to shoulder harness or lap belt. Red, Blue, Black

SIM23020..\$49.95



Nomex Socks

Extra Plush

- Knitted from extra-plush Nomex.
- Natural or Black. • One size fits all

SIM23027\$29.95



Nomex Head Socks

- Knitted from extra-plush Nomex
- Single or dual eyeport
- Colors: Black and Natural

Single Eyeport .SIM23000 .\$79.95
Dual EyeportSIM23003 .\$79.95

FIA Nomex Head Socks

It features a frontal design utilizing a dual layer of Nomex for increased protection. • Colors: Natural

Single Eyeport..SIM23004W .\$79.95
Dual EyeportSIM23005W .\$79.95



Nomex Head Skirt

Single layer 12 oz. Nomex. Keeps dust & debris out. Attaches easily with speedfit system. Black only

StandardSIM23012BK ...\$96.90
ContouredSIM23013BK ...\$99.95
Larger Opening ..SIM23014BK ...\$99.95



CarbonX Head Skirt

StandardSIM23012C ...\$99.95
ContouredSIM23013C ...\$99.95
Larger Opening ..SIM23014C ...\$99.95

FIRE SUITS



Legend II Suit 1 Layer SFI-1

An affordable SFI.1 rated tailored firesuit. FR Cotton suit includes a wrap-around around collar. 360 degree full arm gussets, straight leg cuffs and front pockets.

	Black/Black	Gray/Black
S	SIML202171	SIML205171
M	SIML202271	SIML205271
L	SIML202371	SIML205371
XL	SIML202471	SIML205471

\$199.95



Crossover Suit 2 Layer SFI-5

It is SFI.5 rated with multi-layers of fire protection. Banded collar and straight leg cuffs. This slimline design pattern stands out at the track. Attractive bag gusset is designed for comfort. Plus also includes 360° arm gussets.

	Gray/White/Grp	Bk/White/Gray	Red/White/Bk
S	SIM1904121	SIM1902121	SIM1903121
M	SIM1904221	SIM1902221	SIM1903221
L	SIM1904321	SIM1902321	SIM1903321
XL	SIM1904421	SIM1902421	SIM1903421

\$549.00



Driving Suit STD. 6 SFI-1

SFI 1 racing suit features 3 stripe design with woven satin/twill fabric and zippered patch style breast pocket.

Single Layer Nomex Suits.....\$319.00

	Black	Red	Blue
Small	SIM0302111	SIM0303111	SIM0304111
Medium	SIM0302211	SIM0303211	SIM0304211
Large	SIM0302311	SIM0303311	SIM0304311
X-Large	SIM0302411	SIM0303411	SIM0304411
XX-Large	SIM0302511	SIM0303511	SIM0304511

1 Layer

S
U
I
T

J
A
C
K
E
T

P
A
N
T
S



Single Layer Nomex Jacket.....\$319.00

	Black	Red	Blue
Small	SIM0302112	SIM0303112	SIM0304112
Medium	SIM0302212	SIM0303212	SIM0304212
Large	SIM0302312	SIM0303312	SIM0304312
X-Large	SIM0302412	SIM0303412	SIM0304412
XX-Large	SIM0302512	SIM0303512	SIM0304512

Single Layer Nomex Pants.....\$189.00

	Black	Red	Blue
Small	SIM0302113	SIM0303113	SIM0304113
Medium	SIM0302213	SIM0303213	SIM0304213
Large	SIM0302313	SIM0303313	SIM0304313
X-Large	SIM0302413	SIM0303413	SIM0304413
XX-Large	SIM0302513	SIM0303513	SIM0304513

Driving Suit STD. 19 SFI-5

SFI 5 racing suit features woven satin/twill fabric with vertical quilting and zippered patch style breast pocket.

Double Layer Suits.....\$479.00 (XXL...\$550.85)

	Black	Red	Blue
Small	SIM0402111	SIM0403111	SIM0404111
Medium	SIM0402211	SIM0403211	SIM0404211
Large	SIM0402311	SIM0403311	SIM0404311
X-Large	SIM0402411	SIM0403411	SIM0404411
XX-Large	SIM0402511	SIM0403511	SIM0404511

2 Layer

S
U
I
T

J
A
C
K
E
T

P
A
N
T
S



Double Layer Jackets.....\$550.85 (XXL...\$550.85)

	Black	Red	Blue
Small	SIM0402112	SIM0403112	SIM0404112
Medium	SIM0402212	SIM0403212	SIM0404212
Large	SIM0402312	SIM0403312	SIM0404312
X-Large	SIM0402412	SIM0403412	SIM0404412
XX-Large	SIM0402512	SIM0403512	SIM0404512

Double Layer Pants.....\$332.35 (XXL...\$332.35)

	Black	Red	Blue
Small	SIM0402113	SIM0403113	SIM0404113
Medium	SIM0402213	SIM0403213	SIM0404213
Large	SIM0402313	SIM0403313	SIM0404313
X-Large	SIM0402413	SIM0403413	SIM0404413
XX-Large	SIM0402513	SIM0403513	SIM0404513

Sportsman Elite II 2 Layer

It come with many of the same features as our MTO suits at half the price. Contrasting Platinum chest band and white piping. Satin/Twill with fleece lining. Banded collar. 360° arm gusset. Epaulets. Patch style pockets. Straight leg cuffs and Colored rib cuffs. SFI .5 Rated.

	Black	Red	Blue
S	SIM1502111	SIM1503111	SIM1504111
M	SIM1502211	SIM1503211	SIM1504211
L	SIM1502311	SIM1503311	SIM1504311
XL	SIM1502411	SIM1503411	SIM1504411

\$499.00



XXL	SIM1502511	SIM1503511	SIM1504511
-----	------------	------------	------------

\$573.85

Now available In Jacket and Pants

"Fire Suit Cleaner"



Trial Wash Kit (4 oz. Wash and 4 oz. Spot Cleaner)

It effectively cleans Nomex fabric in std washing machines. It is expressly designed to remove the unique oils, fuel, and soils that are often encountered in the racing environment. Plus it contains an antimicrobial agent to inhibit the growth of bacterial odors, so you'll feel fresh longer.

Trial Wash KitSIMMLVTK44...\$9.95

Helmet Cleaners

Cleaner and Polish in one spray designed to keep helmets clean, shining and protected. Safe to use on all finishes & visors. 4 oz....SIMMLHCP4...\$5.95

Refresher to keep the inside of helmet clean. 4 oz....SIMMLHFR4...\$5.95

Anti-Fog to keep the inside of visor clear. 4oz.....SIMMLHAF4...\$5.95

Rain Repel on outside of visor. 4 oz.....SIMMLHRR4...\$5.95



Helix 2 Layer

It is a part of our DNA strand of high performance racing products. DNA products are designed with athletic performance enhancing features engineered to reduce weight and driver restrictions. SFI.5 Rated. DuPont Nomex fabric. 270 degree arm and back gussets. Knee and Inner Thigh Stretch Panels. Lower back stress relief panel. Upper back ventilation port. No bulk, weight saving patch pockets and embroidered trim and logo. Color: Black/Grey or Red/Grey. Adult S-XXL. Youth XS-XL.

Adult SuitSIMHX.....\$699.00

Youth SuitSIMHXY ...\$399.00



Adult and Youth Available

Simpson Standard Size Chart

Size	Chest	Waist	Hip	Inseam	Neck	Height	Weight
Small	30-34	26-30	33-37	31	14.5	5'5" to 5'7"	115 to 130
Medium	34-38	30-34	37-41	32	15.5	5'7" to 5'10"	140 to 165
Large	38-42	34-38	41-45	33	16.5	5'10" to 6'2"	175 to 200
X-Large	42-46	38-42	45-49	34	17.5	5'11" & over	210 to 225
XX-Large	46-50	42-46	49-53	35	18.5	5'11" & over	235 to 250

Qualifier Suit 2 Layer SFI-5

It is lightweight and extremely breathable and features our softest rib knit lining. The Qualifier has pre-curved floating sleeves and straight leg cuffs with a two-tone modern design. Satin Twill with soft rib knit lining. Straight cut leg. 360° Full arm gusset. Ultra-soft knit cuffs. Colors: Black/Grey, Blue/Grey, and Red/Grey.

	Black/Gray	Red/Gray	Blue/Gray
S	SIML202171	SIML205171	SIML205271
M	SIML202271	SIML205271	SIML205271
L	SIML202371	SIML205371	SIML205271
XL	SIML202471	SIML205471	SIML205271

\$199.95



SFI-15 & SFI-20 Standard Suit Signature Knit Only Nomex

Simpson's Drag suits features Signature knit fabric with vertical quilt, built in arm restraints, and full arm gussets.

SFI-20		SFI-15	
Suits - Black		Suits - Black	
SSIM4802131..	\$1749.00	SSIM4902131..	\$1549.00
MSIM4802231..	\$1749.00	MSIM4902231..	\$1549.00
LSIM4802331..	\$1749.00	LSIM4902331..	\$1549.00
XLSIM4802431..	\$1749.00	XLSIM4902431..	\$1549.00
XXL ..SIM4802531..	\$2011.35	XXL ..SIM4902531..	\$1781.35
Jacket - Black		Jacket - Black	
SSIM4802134..	\$1080.00	SSIM4902134..	\$960.00
MSIM4802234..	\$1080.00	MSIM4902234..	\$960.00
LSIM4802334..	\$1080.00	LSIM4902334..	\$960.00
XLSIM4802434..	\$1080.00	XLSIM4902434..	\$960.00
XXL ..SIM4802534..	\$1242.00	XXL ..SIM4902534..	\$1104.00
Pants - Black		Pants - Black	
SSIM4802133..	\$719.00	SSIM4902133..	\$639.00
MSIM4802233..	\$719.00	MSIM4902233..	\$639.00
LSIM4802333..	\$719.00	LSIM4902333..	\$639.00
XLSIM4802433..	\$719.00	XLSIM4902433..	\$639.00
XXL ..SIM4802533..	\$826.85	XXL ..SIM4902533..	\$734.85



Youth Legend II 2 Layer Suit

SFI-5 with SFI Tag

Double racing stripes on arms and legs. Includes SIM logo patch on arms and Nomex ribbed cuff. Stylish inset pockets & banded racing collar. Traditional cuffed legs. Made with premium fire retardant woven satin/twill fabric with fleece lining. Sizes: XS-XL

SIMY402.....\$269.95

Junior Simpson Standard Size Chart							
Size	Chest	Waist	Hip	Inseam	Neck	Height	Weight
Small	31-33	24-26	29-31	23	12	4'1" to 4'5"	60 to 75
Medium	33-36	26-28	31-33	24	13	4'5" to 5'0"	75 to 90
Large	36-38	29-31	34-36	26	13	5'0" to 5'4"	90 to 105
X-Large	39-41	32-34	38-40	28	14	5'4" to 5'6"	105 to 120



Super Sport Glove SFI 3.3/1 (1 Layer)

The Super Sport is an entry level racing glove that protects and performs. Changed Inside Seam. This is an SFI 3.3/1 certified glove of Nomex construction. This is an SFI 3.3/1 certified glove of Nomex construction with leather palm and silicone graphics. Color: Black. Sizes S-XL.
SIMSS...\$79.95

SFI 3.3/1 tagged

Impulse SFI 3.3/5 (2 Layer)

The Impulse Professional racing glove provides protection and grip in all the right areas. Inside Seam. SFI 5 Rated Racing Glove with Nomex construction. Exceptionally soft palm constructed of goat leather. Colors: Red, Black, and White. Sizes XXS-XXL.
SIMIM...\$99.95

SFI 3.3/5 tagged

Hi-Vis SFI 3.3/5 (2 Layer)

The Hi-Vis racing glove was developed for professional drivers who prefer the feel of an all leather palm. This is an SFI 3.3/5 approved racing glove w/Nomex & leather construction. Colors: Black w/Yellow Trim, Fluorescent Yellow w/Black Trim Size: XS-XXL.
SIMHV...\$119.95

SFI 3.3/5 tagged

Predator SFI 3.3/5 (2 Layer)

Meets SFI 3.3/5. Includes SFI tag. The Predator Glove is constructed of Nomex, the fabric of choice for protective gear. Nomex's reduced heat transfer capabilities bring an unmatched level of protection. The Predator also features an extra long bunch free gauntlet and knock out style that is sure to get you noticed. Colors: Black and White. Sizes S-XL.
SIM20800...\$139.95

SFI 3.3/5 tagged

Competitor SFI & FIA Approved (2 Layer)

Meets SFI 3.3/5 & FIA requirements. Nomex construction; distinctive white trim out. Silicon palm and touch points for superior grip and limited bunching. Colors: Red, Black, White, and Pink. Sizes S-XL. (XXL in black only)
SIM21300...\$139.95

SFI 3.3/5 tagged

Wheeler Glove SFI 3.3/5 (2 Layer)

Certified to SFI 3.3/5 standard, the aggressively styled Wheeler Racing Glove features minimal seam construction and optimized levels of grip via a newly designed leather palm and fingers. Fire-resistant aramid fiber main construction Mid length gauntlet with convenient pull tab Color: Black or Red. Sizes S-XL.
SIMWH...\$149.95

SFI 3.3/5 tagged

Vortex SFI 3.3/5 (2 Layer)

The Vortex is an SFI 3.3/5 rated professional racing glove with Nomex construction. Strategically placed wrist bone padding provides additional protection in this stressed area. External seams and pre-curved palms provide comfort. Tapered and pre-curved fingers and fourchettes give the driver excellent control. Silicone palm gripper design and striking embroidered knuckle logo add to the Vortex gloves' appeal. Black/White or Grey/White. Sizes S-XL.
SIMVR...\$159.95

SFI 3.3/5 tagged

DNA Gloves SFI 3.3/5 (2 Layer)

It is a high performance driving glove using knit Nomex® that conforms to each individual driver's hands for a unique custom fit. SFI 3.3/5 certified, the DNA glove features external seams, tapered and pre-curved fingers, pre-curved palm, exclusive DNA design silicone palm and finger grips, strategically placed knuckle and wrist bone padding and performance inspired style lines. Wear the DNA for unmatched comfort and performance. Black/Blue, Black/Red, and Black/White. Size S-XL.
SIMDG...\$179.95

SFI 3.3/5 tagged

Young Gun Youth Glove SFI 3.3/5 (2 Layer)

Double layer Nomex knit construction with an SFI 3.3/5 rating. The Young Gun is super stylish and super protective. Available in kids sizing Small, Medium and Large. Color: Black with White and Silver accents.
SIMYGY...\$79.95

Apex Kart Glove

The Apex Kart glove provides protection and grip in all the right areas. Goat leather palms are super soft and pliable. The Apex is offered in a full size range. You will not be disappointed with this glove. This IS NOT SFI Glove. Colors: Red, Blue, Black. Sizes S-XL.
SIMAX...\$39.95

SIMAX...\$39.95

High Top w/SFI Tag

High-top design made of satin suede leather and FR inner fleece lining is SFI 3.3/5 approved. Fleece Nomex lining. Satin suede toe, heel and lace guard reinforcements. Triple layer anterior toe area for added wear protection. Non-slip, super-sensitive PU sole with posi-grip traction. Sizes: 3-14 Black. Sizes: 8-12 Blue, Red including 1/2 sizes.
SIM28000...\$99.95



Midtop

The Midtop shoes is SFI 3.3/5 certified. A single speed-fit closure locks away laces. Achilles relief cut for maximum flexibility. Fleece FR lining. Satin suede toe, heel and lace guard reinforcements. Triple layer anterior toe layer for added wear protection. Non-slip, super sensitive PU sole with posi-grip traction. Attractive Black and Gray two tone design.
SIMMT000...\$99.95



Adrenaline w/SFI Tag

Meets SFI 3.3/5 and includes SFI tag. Single Speedfit closure. Low cut Achilles support for maximum flexibility. Fleece Nomex lining. Satin suede toe, heel and lace guard reinforcements. Triple layer anterior toe area for added wear protection. Non-slip, super-sensitive PU sole with posi-grip traction. Black Only. Sizes: 4-14. Including 1/2 Sizes.
SIMAD000...\$129.95



Adrenaline Youth w/SFI Tag

Meets SFI & includes SFI tag. youth 1-3 black, NOT including 1/2 sizes
SIMAD...\$99.95

YOUTH



Stealth Sprint w/SFI Tag

A new take on our ever-popular Sprint shoe, The Stealth sports the Simpson S-Logo & a modified lace guard for those who prefer a futuristic look. SFI 3.3/5 certified and includes SFI Tag. New improved softer leather. High-top design with Simpson's easy to clean leather upper. Simpson's exclusive EnviroGuard lace cover hinges at the tonguebase with full-length speedfit closures on each side. Fleece Nomex lining with flat seams & athletic insert. Super smooth leather toe, lace, and heel guard reinforcements. Type R polyurethane sole with posi-grip pattern. Seven hole lace-up with dual speedfit closure and lace guard. Adjustable wrap-around ankle support. Sloping Achilles heel design. Sizes: 4-14 including 1/2 sizes
SIMSP...\$139.95



DNA Shoes SFI 3.3/5

The DNA Shoe is our newest slim, light-weight, form fitting performance shoe with heat releasing perforated panels designed to meet the needs of today's fastest drivers. SFI 3.3/5 certified. DuPont Nomex lining. Plush tongue and ankle padding. Exclusive pedal sensitive Red Rubber Sole. Colors: Black/Red, Black/White.
SIMDA...\$199.95



Fire Resistant Laces

Size: 48". Colors: Black Only.

SIMFRLACES...\$4.95

Shoe Sizing Conversion Chart

U.S. Men	U.S. Women	U.S. Men	U.S. Women
4.....	5.5	8.5.....	10.5
4.5.....	6	9.....	11
5.....	6.5	9.5.....	11.5
5.5.....	7	10.....	12
6.....	7.5	10.5.....	12.5
6.5.....	8	11.....	13
7.....	9	11.5.....	13.5
7.5.....	9.5	12.....	14
8.....	10		

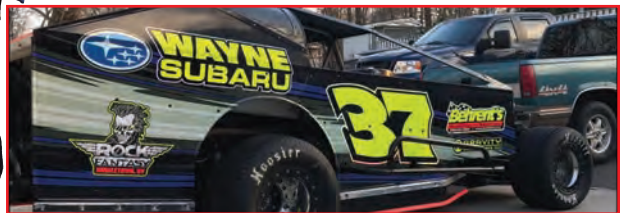

Apex Kart Jacket

Our ripstop CarbonX sleeve provides heat protection and reinforcement in an area that is prone to heat and stress. An easy to wear rear tuck flap keeps the jacket from riding up during action periods but still looks great out of the kart. Sizes S-XXL. Colors Red & Black. NOT Fire Resistant

	Black	Red	
S.....	SIM0102182	SIM0103182	\$179.95
M.....	SIM0102282	SIM0103282	\$179.95
L.....	SIM0102382	SIM0103382	\$179.95
XL.....	SIM0102482	SIM0103482	\$179.95
XXL.....	SIM0102582	SIM0103582	\$206.94



SEAT BELTS

5-Point Std Latch & Link Seat Belts



Latch & Link

Drop forged alloy steel with cadmium plating. Standard 3" military specification webbing on shoulder and lap belts with heat cut and sealed ends. Pull up or pull down adjusters. V-type or Individual shoulder harnesses. Adjusters include anti-slip springs. No left side adjuster option available. Floor mount, bolt-in seat belts, or wrap around. **Add R, BK, or BU at the end of the part # for color. R=Red, BK=Black, and BU=Blue.**

Std Latch and Link

62" Seat Belt		Pull Up	Bolt In	SIM29061.....	\$129.95
62" Seat Belt	Hans Shoulders	Pull Up	Bolt In	SIM29061-30010	\$129.95
55" Seat Belt		Pull Down	Bolt In	SIM29063.....	\$129.95
55" Seat Belt	Hans Shoulders	Pull Down	Bolt In	SIM29063-30010	\$129.95
55" Seat Belt	Wrap Around	Pull Down		SIM29064.....	\$129.95
55" Seat Belt	Wrap - Hans	Pull Down		SIM29064-30010	\$129.95
55" Seat Belt	Roll Bar V Harness	Pull Down	Bolt In	SIM29065.....	\$129.95
Sprint Car	No Right Side Adj.	Pull Down		SIM29066.....	\$129.95
Sprint Car	No Right Side Adj. Hans	Pull Down		SIM29066-30010	\$129.95
Sprint Car	No Right Side Adj.	Pull Down		SIM29075.....	\$129.95
Sprint Car	No Right Side Adj. Hans	Pull Down		SIM29075-30010	\$129.95

Add "P" to the end of Part # for Platinum Series (+\$10)

SFI 16.1 Sport Latch & Link



The Simpson SFI 16.1 Sport Latch and Link belt system features polyester construction for maximum protection and minimum elongation. This belt system is affordable and configured to be adaptable to many race cars. SFI 16.1 Sport L&L, Pull Down SIM29043..\$109.95



Sprint Car Ratchet Belts 16.1 Latch & Link Ratchet Seat Belts

For when the ride is especially rough and you want to keep those belts tightened down. Ratchet belts are available in left side or right side, with Alum or Steel adjusters. These belts from our Platinum Plus line are manufactured at North Carolina facility. In other words, like all Simpson belts, made in the USA! Black Only.

w/ Steel Adjs, Left side fixed, Right side Ratchet	SIMSB.51201	\$329.95
w/ AL Adjs, Right-side Ratchet	SIMSB.51202	\$379.95
w/ Steel Adjs, Left-side Ratchet	SIMSB.51203	\$329.95
w/ AL Adjs, Left-side Ratchet	SIMSB.51204	\$379.95



5-Point Camlock Seat Belts



Camlock Lever Technology

Try our new lever Camlock/Clip system redesigned to be 15% lighter. A unique internal release mechanism is engineered to eject belts clip quickly. Our belts clips are interchangeable with rotary camlock. These systems feature a sleek matte black finish.

Add R, BK, or BU at the end of the part # for color. R=Red, BK=Black, and BU=Blue.

Camlock

Formula Car 6-Way		Pull Up	Bolt-InSIM29114	\$279.95
62" Seat Belt	Floor Mount	Pull Up	Bolt-InSIM29102	\$249.95
55" Seat Belt		Pull Up	Bolt-InSIM29104	\$249.95
55" Seat Belt	Roll Bar V Harness	Pull Down	Bolt InSIM29108	\$249.95
55" Seat Belt		Pull Down	Bolt InSIM29110	\$249.95
55" Seat Belt	Hans Shoulder	Pull Down	Bolt InSIM29110-30010	\$249.95
55" Seat Belt	Wrap Around	Pull Down	Bolt InSIM29112	\$249.95

Add "P" to the end of Part # for Platinum Series (+\$10)



5 Point Drag Camlock

Drag Racing 5-Way Seat Belt covered with Nomex SIM29116.....\$279.95

Add "P" to the end of Part # for Platinum Series SIM29116P....\$289.95

5-Point Std Latch F/X Seat Belts

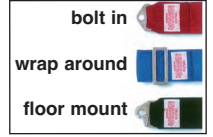
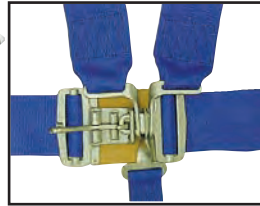

Latch F/X

Compact integrated latch, link, and adjuster reduces size by 30%. Drop forged construction reduces weight by 30% V-type or individual shoulder harnesses. Adjusters include anti-slip spring. No left side adjuster option available. Add R, BK, or BU at the end of the part # for color. R=Red, BK=Black, and BU=Blue.

Latch F/X

62" Seat Belt	Wrap Around	Pull Down	SIM29072\$129.95
62" Seat Belt	Wrap Around	Hans Pull Down	SIM29072-30010\$129.95
62" Seat Belt		Pull Down	Bolt-InSIM29073\$129.95
62" Seat Belt	Hans Shoulders	Pull Down	Bolt-InSIM29073-30010\$129.95
62" Seat Belt	Roll Bar V Harness	Pull Down	Bolt-InSIM29074\$129.95

Add "P" to the end of Part # for Platinum Series (+\$10)

Which style do I need?

Std Latch and Link

Compact latch and link assembly, lap belt adjusters are located in between the latch assembly and the anchor point.

Latch F/X

Full size latch assembly, adjusters are located on the latch assembly, preventing interference with the seat.

SFI 16.5 Seat Belts



Approved SFI 16.5
Also available in black platinum.



Rotary Series Camlock

Pull Down	Bolt-in BlackSIM29118SO	...\$249.95
Pull Up	Bolt-in BlackSIM29119SO	...\$249.95

Latch & Link Series

Pull Down	Bolt-in BlackSIM29054SO	...\$159.95
Pull Up	Bolt-in BlackSIM29055SO	...\$159.95

Rotary Series Camlock w/2" Uppers

Pull Down	Bolt-in BlackSIM29828SO	...\$249.95
Pull Up	Bolt-in BlackSIM29829SO	...\$249.95

Latch FX Series

Pull Down	Bolt-in BlackSIM29073SO	...\$159.95
Pull Down	Bolt-in PlatinumSIM29073SP	...\$164.95

6-Point Harness



Latch and Link (Pull Down, Bolt-in)
SIM290636\$139.95

Latch and Link (2" Harness, Pull Down, Bolt-in)
SIM290636H\$139.95

Latch F/X
SIM290736\$139.95

Latch F/X
SIM290736H\$139.95



Quarter Midget Seat Belts



Quarter Midget Seat Belts

Wrap around seat belt pull down individual harness wrap around. Add R, BK, or BU at the end of the part # for color. R=Red, BK=Black, and BU=Blue.

Roll Bar Wrap around HarnessPull DownSIM29025\$99.95
Individual Harness Bolt inPull DownSIM29026\$99.95
Roll Bar Wrap around HarnessPull UpSIM29025BKPU\$99.95

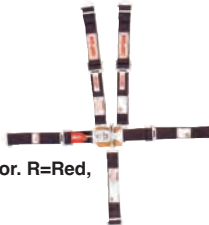

HELMETS



The 1320

It features a wide eyeport for a panoramic view. 2 adjustable forehead vents are used both to cool the head and defog the shield. Sizes: S-XL. Standard Colors are Silver, White, Gloss Black, and Flat Black. SA2015.



Std.....IMP14515. **\$329.00**

Champ

Tear-Offs
RAC10231C

It features a radical chinbar design that extends coverage over the mouth & nose and acts as a breath deflector. The expanded eyeport works in every racing cockpit and on every racing bike. Sizes available are S-XL. Std colors are Silver, Black & white are available. SA2015.



IMP13015.....**\$549.00**

Charger

Tear-Offs
RAC10230C

It features a unique wrap-around eyeport for wide angle panoramic vision. This computer designed interior features an active memory foam in the liner and cheekpads that adjust and customize the fit every time you put the helmet on. Sizes available are S-XXL. Std colors are Silver, Black & White. SA2015.



IMP14015....**\$499.00**



Ultralightweight

Draft TS

It offers an exceptional range of front and peripheral vision. The extended wicker bill captures downward airflow to reduce helmet lifting and buffeting while our "Intelligent Gray Matter" liner (a variable-density, single-piece helmet liner) is upholstered with fire retardant soft-knit Nomex for the ultimate in comfort. Adult Sizes: XS-XL. SA2015.



Draft TS.....IMP19715 ...**\$795.00**
Carbon Fiber.....**\$1,500.00**



Mud-X Cleaner

Cleans and shines plastic, polycarbonate, chrome, fiberglass, paint, vinyl and leather. Leaves an invisible coating that protects surfaces and repels dirt, dust, fingerprints, smudges and bugs. **Excellent for helmet shields.**

ALL78232.....**\$12.99**



Adult Helmet Sizing Chart

X-Small	6 3/4" to 6 7/8"	20 5/8" to 21"
Small	6 7/8" to 7"	21 5/8" to 22"
Medium	7 1/8" to 7 1/4"	22 1/2" to 22 3/4"
Large	7 3/8" to 7 1/2"	23 1/4" to 23 5/8"
X-Large	7 5/8" to 7 3/4"	24" to 24 1/2"

Youth Helmet Sizing Chart

Small (2 inserts)	6 1/8" to 6 1/4"	19" to 19 1/4"
Medium (1 insert)	6 3/8" to 6 1/2"	19 1/2" to 20"
Large (No insert)	6 5/8" to 6 3/4"	20 1/2" to 21"

Measure the head 1" above the eyebrows across a point at the back of the head.

Junior Helmets

Mini Vapor

"Ripple Effect" boundary layer aerodynamic features incorporated in the shell construction and interchangeable cheekpads for a custom fit. SA2015. Colors are white, silver, shiny black, & flat black.



IMP11315..**\$399.00**

Quick-Fit memory foam sizing pads (included) SFI/FIA & DDT Approved

Mini Champ

Featuring expanded chinbar design and interchangeable cheekpads for custom fit. SA2015. Colors available are white, silver, shiny black, and flat black.



IMP11415..**\$399.00**

Silver

White

Gloss Black

Flat Black

Carbon Fiber



\$20 More

\$\$\$ More

Ultralightweight

Vapor

It is the result of extensive 3D modeling to create a specially designed Ripple Effect aerodynamic boundary layer to stabilize the helmet under high speed airflow, so this is the perfect open-wheel helmet. Constructed of super lightweight Carbon-Kevlar tri-weave, a composite taken from the aerospace industry, the Vapor also includes Impacts Kevlar tri-weave, a composite taken from the aerospace industry, the Vapor also includes Impacts Gray Matter helmet liner, Impact's standard eyeport with a three-position detent 1/8" polycarbonate shield, interchangeable sizing cheekpads with dual D-ring closure. Sizes: S-XL. Std colors are Silver, Flat/Gloss Black, white, & carbon fiber are available. SA2015.



Std...IMP12515..**\$795.00** Tear-Offs
Carbon Fiber..**\$1,500.00** RAC10230C

Ultralightweight

Vapor LS

It features Impact's lightweight tri-weave construction and is loaded with features. Aggressive chin-bar styling provides for additional room for the microphone while integrated vents offer cooling, fog-free. A wide-angle, wrap-around eye port, a Kevlar® chin strap with dual D-ring closure, and a 1/8" polycarbonate shield with exceptional visual acuity finish off the newest addition to Impact's line of Made in the USA helmets. Sizes: S-XL. Std colors are Silver, Flat/Gloss Black, white, and carbon fiber are available. SA2015.



Std...IMP12915. **\$795.00** Tear-Offs
Carbon Fiber..**\$1,500.00** RAC10230C

Cheek Pads

If your helmet fits tight or lose in the cheek area.

Charger/Champ/Vapor
IMP11111121.....Thin Pad.....**\$39.95**
IMP11111122.....Standard Pad..**\$39.95**
IMP11111123.....Thick Pad.....**\$39.95**

1320/1320 Air/Air Draft
IMP11111131.....Thin Pad.....**\$39.95**
IMP11111132.....Standard Pad..**\$39.95**
IMP11111133.....Thick Pad.....**\$39.95**

Mini Champ/Mini Vapor
IMP11111141.....Thin Pad.....**\$39.95**
IMP11111142.....Standard Pad..**\$39.95**
IMP11111143.....Thick Pad.....**\$39.95**

Velocity
IMP11111151.....Thin Pad.....**\$39.95**
IMP11111152.....Standard Pad..**\$39.95**
IMP11111153.....Thick Pad.....**\$39.95**

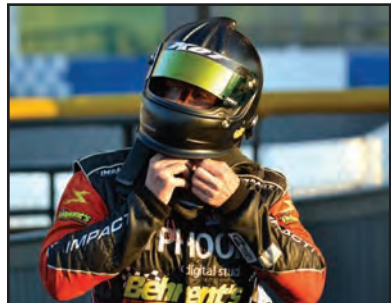

FRESH AIR HELMETS



IMPACT
Tear-Offs
RAC10209C
The 1320 Side Air

Same value-packed options as Impact's 1320 helmet but with the addition of fresh air comfort circulated through air port channels directed onto the visor, minimizing fog and contaminates while also providing fresh air and cooling comfort. It is a custom handcrafted fiberglass shell manufactured to Impact's exacting standards providing racers with an affordable Made in the USA. Sizes: XS-XL. Colors are Silver and Flat Black. SA2015.

Side Air .IMP14715. **\$379.00**



The 1320 Tear-Offs Top Air
RAC10209C

Same value-packed options as the 1320 helmet but with the addition of fresh air comfort circulated through air port channels directed onto the visor, minimizing fog and contaminates while also providing fresh air and cooling comfort. It is a custom handcrafted fiberglass shell manufactured to Impact's exacting standards providing racers with an affordable Made in the USA helmet. Sizes: XS-XL. Colors are Silver & Flat Black. SA2015.

Top Air ..IMP14815. **\$399.00**



Tear-Offs RAC10230C Super Charger

It features a new air induction design we call the Head Dress. It utilizes fortified Speed Channels to emphasize air-flow across the shield. Adult sizes: XS-XL. Std colors are Silver. Black and white are also available. SA2015.

Top Air.....IMP17015.. **\$549.00**
Side Air.....IMP17915.. **\$549.00**



Air Draft

It utilizes Impact's new solution to air induction that provides air conditioning, anti-fog and a system to reduce air contamination inside the helmet. Plus the latest in tech, performance and function resulting in this handmade ultra lightweight helmet. Sizes: S-XL. Std colors are Silver. Flat/Gloss Black, white, & carbon fiber are available. SA2015.

Top AirIMP19315... **\$849.00**
Side AirIMP19615... **\$849.00**
Carbon Fiber **\$1,599.00**



Air Vapor

It provides air conditioning, anti-fog and a system to reduce air contamination inside the helmet. SFI/FIA and Snell Approved. Sizes: S-XL. Std colors are Silver. Flat/Gloss Black, white & carbon fiber are available. SA2010.

Top AirIMP16015 **\$849.00**
Side AirIMP16115..... **\$849.00**
Carbon Fiber..... **\$1,599.00**



Nitro

A self contained air filtration system that functions solo to purify inhaled air, or in conjunction with onboard bottle air systems. SNELL & SFI/FIA approved. Sizes: S-XL. Std colors are Silver. Flat/Gloss Black, white, and carbon fiber are available. SA2015.

IMP18015.... **\$1,199.00**
Carbon Fiber. **\$1,899.00**



Air Draft OS20

It is offered in the Carbon-Kevlar tri-weave composite. The tri-weave composite is available in four standard colors including silver, white, and two different blacks - flat and glossy. Std width removable cheek pads are included however a variety of cheek pads ranging from thin to thick are available. With the Air Draft OS20 offered in helmet sizes from XS to XL and customizable cheek pad thicknesses. Like Impact by MasterCraft Safety's full line of helmets, the Air Draft OS20 manufactured in USA. Adult sizes: XS-XL. SA2015.

Std...IMP19915.. **\$849.00**
Carbon Fiber.. **\$1,599.00**



Tear-Offs RAC10209C Air Vapor SC

It offers an aggressive chin bar design providing more room for the microphone while increasing driver comfort and reducing fog. It also features a tapered lower design allowing for additional clearance between the helmet and the frontal head restraint devices. The Air Vapor SC offers a truly customized fit with a interchangeable, variable-density cheek pads. Made in the USA helmets. Adult Sizes: XS-XL. SA2015.

Top Air.....IMP16915 **\$849.00**
Top Air Carbon Fiber..... **\$1,599.00**



Shield Bags

Hold up to 2 shields in our handy shield carrying case that comes with a soft, yet sturdy material outside and an optical quality cloth inside to separate the two.

IMP81500010... **\$10.00**



Shield Foam Kits

It features a Nomex outer layer for added fire protection.

1/4"IMP10000025 **\$25.00**
1/8"IMP10000026 **\$25.00**



Breath Deflector

It is designed to direct breath down & away from the face shield to reduce fogging.

IMP10000012... **\$30.00**



Replacement Air Adapters for Fresh Air Impact Helmets

Made of plastic.

RoundIMP10000030
OvalIMP10000031
90 degree ..IMP10000032.. **\$10.00**



Pivot Kits

Made of metal.

IMP10000000.. **\$14.95**

IMPACT							
Anti Fog Shields	Clear	Light Smoke	Dark Smoke	Amber	Yellow Chrome	Blue Chrome	Chrome
Helmet Types	\$59.00	\$65.00	\$65.00	\$69.00	\$63.00	\$63.00	\$63.00
Vapor/Air Vapor/Vapor SC/							
Charger/Super Charger/Draft	IMP12199901	IMP12199902	IMP12199903	IMP12199904	IMP12100905	IMP12100906	IMP12100908
Champ/Nitro/Drag Champ	IMP13199901	IMP13199902	IMP13199903	IMP13199904	IMP13100905	IMP13100906	IMP13100908
Air Draft/Draft TS/SS/SS Air							
Spider/1320/Fueler	IMP19399901	IMP19399902	IMP19399903	IMP19399904	IMP19300905	IMP19300906	IMP19300908
Mini Champ	IMP11499901	IMP11499902	IMP11499903	N/A	IMP11400905	IMP11400906	IMP11400907
Mini Vapor	IMP11399901	IMP11399902	IMP11399903	N/A	IMP11300905	IMP11300906	IMP11300907

IMPACT New Style

Racer Suits 2 Layer SFI-5

Racer 2 Layer Driving SFI-5 Suits

Black/Blue Black/Red Black/Gray
 S.....IMP24215306...IMP24215307..IMP24215313
 M.....IMP24215406...IMP24215407..IMP24215413
 L.....IMP24215506...IMP24215507..IMP24215513
 XL.....IMP24215606...IMP24215607..IMP24215613
 XXL.....IMP24215706...IMP24215707..IMP24215713..\$599.00
 XXXL.....IMP24215806...IMP24215807..IMP24215813..\$699.00

Racer 2 Layer Driving SFI-5 Jackets

Black/Blue Black/Red Black/Gray
 S.....IMP22515306...IMP22515307..IMP22515313
 M.....IMP22515406...IMP22515407..IMP22515413
 L.....IMP22515506...IMP22515507..IMP22515513
 XL.....IMP22515606...IMP22515607..IMP22515613
 XXL.....IMP22515706...IMP22515707..IMP22515713..\$335.00
 XXXL.....IMP22515806...IMP22515807..IMP22515813..\$435.00

Racer 2 Layer Driving SFI-5 Pants

Black/Blue Black/Red Black/Gray
 S.....IMP23315306...IMP23315307..IMP23315313
 M.....IMP23315406...IMP23315407..IMP23315413
 L.....IMP23315506...IMP23315507..IMP23315513
 XL.....IMP23315606...IMP23315607..IMP23315613
 XXL.....IMP23315706...IMP23315707..IMP23315713..\$310.00
 XXXL.....IMP23315806...IMP23315807..IMP23315813..\$410.00



IMPACT

Carbon6 Firesuit

Impact's Carbon 6 suit blends exceptional form and function with many of the must-have attributes commonly found only in custom suits. Manufacturer certified to comply with the SFI Foundations 3.2A/5 Spec. Functional Back & Auxillary Gusset. Anatomical Stretch Crotch. 360 degree full-floating arm gussets. Inset front pants pockets. With emphasis on driver comfort, Impact incorporated breathable anatomical stretch paneling in strategic areas for increased range of motion providing a superior performance fit. Hand-crafted from lightweight sateen Nomex the Impact Carbon 6 features V-stitch quilting for exceptional thermal performance. Deep inset pockets and bootcut cuffs finish this exclusive two-layer SFI 3.2A/5 rated suit.

Carbon6 2 Layer Driving SFI-5 Driving Suits

Black/Blue Black/Red Black/Gray
 S.....IMP23000306...IMP23000307..IMP23000313
 M.....IMP23000406...IMP23000407..IMP23000413
 L.....IMP23000506...IMP23000507..IMP23000513
 XL.....IMP23000606...IMP23000607..IMP23000613
 XXL.....IMP23000706...IMP23000707..IMP23000713..\$999.00



Adult Standard Firesuit Sizing

Size	Height	Weight (lbs.)	Chest	Waist	Hips	Torso	Inseam
Adult S	5'4" to 5'6"	130 to 150	38"-40"	29"	33"	27"	31"
Adult M	5'6" to 5'8"	150 to 170	42"-44"	32"	36"	28"	31"
Adult L	5'8" to 5'10"	170 to 190	46"-48"	36"	40"	29"	32"
Adult XL	5'10" to 6'1"	190 to 210	50"-52"	39"	44"	31"	33"
Adult XXL	6' to 6'2"	220 to 240	54"-56"	44"	47"	32"	33"

Racer 2 Layer Suit SFI-5

Soft and breathable Gabardine Nomex III finish fire resistant shell lined with cool and comfortable ImpactMAX moisture management knit liner. 360° floating sleeve full arm gusset. Expandable knit lower back Lumbar panel allows ease of movement. Box quilting. Wide athletic shoulder silhouette aids in movement. Inset pant pocket. Straight leg cuffs. Ribbed fire resistant wrist and ankle cuffs. Banded collar and adjustable waist belt.

#1 Seller!



Racer 2 Layer SFI-5 Driving Suits

	Black Suit	Black Jacket	Black Pants
SmallIMP24215310IMP22515310IMP23315310
MediumIMP24215410IMP22515410IMP23315410
LargeIMP24215510IMP22515510IMP23315510
X-LargeIMP24215610IMP22515610IMP23315610
2X-LargeIMP24215710IMP22515710IMP23315710

\$310.00 \$310.00 \$310.00

3X-Large.....IMP24215810IMP22515810.....IMP23315810
\$410.00 \$410.00 \$410.00

The Paddock 2 Layer SFI-5

Impact's Paddock suit is the ideal choice for the budget-minded pit crew or driver. Featuring the same excellent fitment and style that Impact is famous for, the Paddock is manufactured from three layers of flame-retardant treated cotton and surpasses the SFI 3.2A/5 standard. The multi-layer quilted construction adds valuable seconds of protection against direct flame and heat transfer while adding durability and comfort. Offered with a boot cut pant leg and available as a one-piece overall or two-piece jacket and pant combo, the Paddock suit is available in sizes ranging from small to 3XL. Colors: Black Only



Paddock 2 Layer Driving SFI-5 Driving Suits Black

	Suit	Jacket	Pants
SIMP21100310IMP21110310IMP21120310
MIMP21100410IMP21110410IMP21120410
LIMP21100510IMP21110510IMP21120510
XLIMP21100610IMP21110610IMP21120610
XXLIMP21100710IMP21110710IMP21120710
XXXLIMP21100810IMP21110810IMP21120810

\$160.00 \$160.00 \$160.00



IMPACT

SFI 15 & SFI-20 Team Drag 2-Piece Firesuit

SFI Foundation's 3.2A/15 Specification. Fire-retardant outer layer with cool, comfortable proprietary multi-layer inner. 360 degree full-floating arm gussets. Comfortable ribbed arm and ankle cuffs (will tuck into your race shoes/boots) for a tight seal and fit. Front patch pants pockets. Available in Black/Red, Black/Gray, and Black/Blue.

IMP29300(size)	SFI-15 Jacket.....	\$629.50
IMP29400(size)	SFI-15 Pants.....	\$599.00
IMP29600(size)	SFI-20 Jacket.....	\$678.00
IMP29700(size)	SFI-20 Pants.....	\$651.00

SFI 15

SFI-20

Junior Drag/ Quarter Midgets Suits

SFI 3.2A-5 Approved

It is constructed of a fire resistant shell fabric designed allow for a growing racer. 1-piece suit with plenty of extra seam allowance to let-out as the young racer grows. Adjustable waist belt. Machine washable. Color: Black. Sizes are Youth SM thru Youth XL.
 • Has built in arm restraints.
 IMP21400.....**\$383.00**



Youth Standard Firesuit Sizing

Size	Height	Weight	Chest	Waist	Hips	Torso	Inseam
Youth S	4'1" to 4'4"	50 to 65	27"-29"	23"	26"	19"	22"
Youth M	4'3" to 4'7"	70 to 90	28"-30"	25"	27"	21"	25"
Youth L	4'5" to 4'9"	80 to 100	34"-36"	27"	31"	23"	27"
Youth XL	4'7" to 4'11"	90 to 120	35"-37"	28"	32"	25"	29"

5-Point Latch and Link System

It includes choice of individual shoulder harness, 60" latch & link lap belts & single anti-sub belt.



Individual Shoulder Sets
 Pull Down Lap 2 Intergrated Adjusters
 IMP59111111.....\$149.95
 Pull Down Lap 2 Intergrated Adjusters
 w/2" Hans Shoulder
 IMP59111111-59888888\$184.95

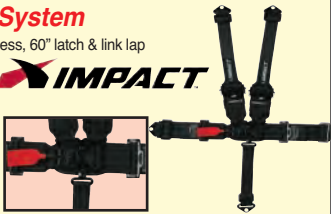

2" Latch & Link System Quarter Midget/Jr. Dragster

• Single 5-Point Sub Belt • Pull Up
 IMP52116661.....\$109.99



2" Cam-Loc System Quarter Midget/Jr. Dragster

• Single 5-Point Sub Belt
 • Pull Up
 IMP57346661.....\$149.95



Anchor Hardware

IMP50000011 .3-Bar Adjuster\$3.00
 IMP50000021 .Bolt-in Anchor\$3.00
 IMP50000031 .Clip-in Anchor\$5.00
 IMP50000041 .Eye Bolt Anchor...\$7.00



Arm Restraints

Padded arm bands with webbed leashes & 2 adjustments for both arm circumference & leash length. Meets SFI requirements. Color: Black
 IMP75000910...\$60.00



Neck Support w/SFI

High density compression foam increases in resistance the more it is compressed. This compression cycle helps control head and neck roll.

Adult Black.....IMP74500010.....\$39.00
 Child Black.....IMP74501010.....\$39.00



Redlined Drag Glove SFI 3.3/20 Certified

Innovation, technology and design have come together to create Impact's newest drag glove offering both comfort and performance. Designed specifically for the drag-strip and featuring superior fire protection with its SFI rating of 3.3/20 and a TPP of over 100, the Impact Redline glove offers an anatomically correct pre-formed shape and suede insert panels on the palm and fingers allow maximum comfort and grip. The zig-zag elastic gauntlet ensures the gloves stay comfortably in place over the fire suit. Adult Sizes S-XXL. Colors: Black Only.
 IMP37500.....\$249.95



Drag/Nitro Over-Boot

Our Impact Top Fuel/Top Alcohol Over-Boot, which fits securely over Impact race shoes, is made with Nomex inner & outer and is designed with a full toe to calf zipper & overlock hook and loop extra-length cover. Black only.
 IMP4900.....\$249.00



Pro Stock Chutes

The 8' crossform chute is used for 200+ mph cars and comes in an 4-point configuration w/pack and pilot chute. The 10' model is designed with an 8-point configuration and includes both pack and pilot chute. Colors: Black/Red/Blue
 8'IMP77008.....\$429.00
 10'IMP77010.....\$465.00



Nylon Nitro Chute

Designed with 200-300+ mph cars in mind. Made to deploy quickly and consistently. The science of parachute design considers: flight stability, deployment force, flow-through, attachment points and packing. Colors: Black/Red/Blue
 Complete Set...IMP77013...\$499.00



10' Sky Jacker Drag Chute

Handmade Crossform design delivers reliable and durable performance for cars up to 200 mph. Complete with nylon pack and pilot chute. Colors: Black, Red, or Blue.
 SIM42020(color) ..\$429.95



IMPACT Helmet Skirt

Available as a do-it-yourself hook and loop attachment, our helmet skirt is manufactured from a soft knit Nomex providing added protection from heat transfer while also reducing dirt and debris from entering the helmet. The 2-layer skirt is available in our std or tapered-in design. The tapered-in design allows the skirt to be tucked into the driving suit more easily while reducing interference between the skirt and frontal head restraint device.



2-Layer Velcro Attachment - Standard.....IMP10000016...\$75.00
 2-Layer Velcro Attachment - Tapered.....IMP10000022...\$75.00

Holeshot 20 Drag Glove

Meets SFI .20. 20% lighter than the competition. Meets SFI 20. Newly developed Nomex technology with conforming stretch for improved dexterity. Made in the USA/Black only. Sizes S-XL.
 SIM37015.....\$299.95



Holeshot 20 Drag Boots

50% lighter than standard drag boots. No side zipper to maneuver. Newly developed Nomex material stretches over the shoe for improved fit. Made in the USA. SFI .20 rating Colors: Black only Shoe Sizes: S (5-1/2 to 7), M (7 to 8-1/2), ML (8-1/2 to 10), L (10 to 11-1/2), XL (11-1/2 to 13)
 SIM37021.....\$399.95



IMPACT Redline Drag Shoe 3.3/20

Impact's Redline SFI 3.3/20 series high top is the ultimate in drag racing protection. Ideal for nitro and alcohol-powered racecars, the Redline features an ultra-plush meta-aramid interior offering an unparalleled level of defense against direct flame and heat transfer. Manufactured from exceptionally lightweight soft-suede exterior, Impact's Redline is designed with an ultra-thin, oil-resistant, and anti-static sole providing superior pedal sensitivity. Featuring a vapor permeable inner sole liner for improved moisture wicking, the Redline also offers a deep Achilles cut-out for maximum range of motion and finishes.
 IMP49107010.....\$425.00



SIMPSON Simpson Beanie

The Beanie sports black with the simpson logo. Stay warm and be yourself.
 SIM43050.....\$15.99



Pull Over Hoodie

Warm up on cool nights in a Simpson Hoodie. Drawstring hood and cozy front pocket.
 SIM43075(Size) ..\$39.99



HELMETS



Tear-Offs
RAC10205C

Sport

The Sport is designed for entry level racers who demand value and quality at an affordable price. The Sport incorporates classic Bell design styling, standard size eye opening, comfortable interior fit and a lightweight composite shell. The all-purpose Sport offers closed face protection, a wide range of features, full ventilation and is a perfect choice for racers on a budget or enthusiasts just entering the sport.

- 281 3mm SRV Shield (SRV-2 Pivot Sys) – Clear Shield
- Snell SA2015 Homologation

Size...White.....Matte Black
S.....BEL1424001.....BEL1424011
M.....BEL1424002.....BEL1424012
L.....BEL1424003.....BEL1424013
XL.....BEL1424004.....BEL1424014
\$399.95 \$399.95

Size...Orange.....Edge
S.....BEL1424021.....BEL1424031
M.....BEL1424022.....BEL1424032
L.....BEL1424023.....BEL1424033
XL.....BEL1424024.....BEL1424034
\$499.95 \$499.95



BR-1

The BR-1 is the first model in the industry that can be used as a traditional helmet, side air forced air or top air forced air model. By utilizing an innovative kit system, racers can now customize the BR-1 to adapt to different forms of racing or seat configurations. It features an aero front chin gurney (duckbill) and comes standard with rear facing Venturi airflow vents installed for dirt track forms of racing. The Top Air and Side Air kits are sold separately with multiple nozzle options.

- 281 3mm SRV Shield (SRV-2 Pivot Sys) – Clear Shield
- Snell SA2015 Homologation

Size...White.....Matte Black
S.....BEL1421001.....BEL1421011
M.....BEL1421002.....BEL1421012
L.....BEL1421003.....BEL1421013
XL.....BEL1421004.....BEL1421014
\$529.95



Add on Air Kits for BR.1 Helmet

Description.....White.....Black
Top Air Kit.....BEL2070041.....BEL2070042
Side Air Kit.....BEL2070039
Side Plate Kit.....BEL2070033.....BEL2070034
\$39.95

Forced Air Adapter (Straight).....BEL2070066 **\$9.95**
Forced Air Adapter (90 Degree).....BEL2070067 **\$12.95**

Pivot Kits & Eyepoint Foam Kit

SRV-1 Pivot Kit (287 SRV).....BEL2020021 \$17.95
SRV-2 Pivot Kit (all others).....BEL2020031 \$17.95
Eyepoint Foam Kit V.10.....BEL2080002 \$12.95

K.1 Pro

The K.1 Pro is a multi-use, full-feature helmet with superior ventilation, aero styling and Bell's aggressive chin bar design and front chin gurney (Duckbill). The K.1 Pro is a great helmet for open wheel racers, closed car racers and kart racers who demand superior features including light weight, excellent fit and multiple ventilation options. It can be used in an open wheel configuration with air intake (included) & w/a closed car configuration w/top forced air insert (sold separately). The K.1 Pro is available in std colors & the Circuit Graphic in Red or Blue.

- 287 3mm SRV Shield (SRV-1 Pivot Sys) – Clear Shield
- Sizes S (57) to XL (61+) • Snell SA2015 Homologation

Size...White.....Matte Black
XXS.....BEL1420001.....BEL1420011
XS.....BEL1420002.....BEL1420012
S.....BEL1420003.....BEL1420013
M.....BEL1420004.....BEL1420014
L.....BEL1420005.....BEL1420015
XL.....BEL1420006.....BEL1420016
\$529.95 \$529.95

Size...Red.....Blue
S.....BEL1420023.....BEL1420033
M.....BEL1420024.....BEL1420034
L.....BEL1420025.....BEL1420035
XL.....BEL1420026.....BEL1420036
\$629.95 \$629.95



GP.3 Tear-Offs RAC10206C

It combines traditional F1 styling, versatile air intake system and lightweight carbon composite shell with leading-edge aerodynamic performance. It is a great option for open wheel, formula racers and karters who demand professional features, performance and comfort. The GP.3's improved shield integration, double screen anti fog (DSAF) visor, rubber gasket seal and manual lever closable air intake vents provide maximum ventilation and clear vision in the most demanding racing environments.

- SE03 3MM DSAF Shield (SV SE03/05 Pivot Sys) –
- Snell SA2015 & FIA8859-2015 Homologation

Size.....White.....Matte Bk
7-1/8".....BEL1313001.....BEL1313011
7-1/4".....BEL1313002.....BEL1313012
7-3/8".....BEL1313003.....BEL1313013
7-1/2".....BEL1313004.....BEL1313014
7-5/8".....BEL1313005.....BEL1313015
7-3/4".....BEL1313006.....BEL1313016
\$729.95

Size.....Carbon

-(7-1/8")-BEL1206001
7-1/8".....BEL1206002
7-1/4".....BEL1206003
7-3/8".....BEL1206004
+(7-3/8") BEL1206005
7-1/2".....BEL1206006
7-5/8".....BEL1206007
7-5/8"+.....BEL1206008
\$999.95



M.8

The M.8 is the next evolution in Bell's legendary M series design concept incorporating traditional styling, enhanced visibility and versatile features allowing the helmet to be used in all forms of racing. The M.8 provides outstanding comfort and features including a lightweight composite shell, Comfort-Plus interior, superior ventilation with manual lever air intake vents and a large eye opening. The M.8 is a great choice for racers who want a LW, multi-purpose helmet with a wider field of vision (especially for those who wear eye glasses) & updated Bell styling & performance.

- SRV-8 3mm SRV Shield (SRV-1 Pivot Sys)
- Snell SA2015 Homologation

Size.....White.....Matte Black
XXS.....BEL1419001.....BEL1419011
XS.....BEL1419001.....BEL1419012
S.....BEL1419003.....BEL1419013
M.....BEL1419004.....BEL1419014
L.....BEL1419005.....BEL1419015
XL.....BEL1419006.....BEL1419016
2XL.....BEL1419007.....BEL1419017
3XL.....BEL1419008.....BEL1419018
4XL.....BEL1419009.....BEL1419019
\$529.95

Size.....Carbon

-(7-1/8").....BEL1208001
7-1/8".....BEL1208002
7-1/4".....BEL1208003
7-3/8".....BEL1208004
7-1/2".....BEL1208005
7-5/8".....BEL1208006
7-3/4".....BEL1208007..... \$949.95



Breath Deflector

Designed to direct breath down and away from the face to minimize fogging. Keeps dust out. Simple installation and removal. Fits all Bell SA2010 rated helmets.

BEL2110001.....**\$19.95**



Tear Off Posts

The alum tail dual hole tearoff posts kits are now available, the new post features two holes so that the post can be used on the SRV shield or the SE shields. Each set of posts will come with a detailed instruction card for both style shields.

BEL2030043.....**\$15.95**



Vador

It is a complete design departure for Bell, incorporating a sinister blunt nose design and fighter pilot style shield. Features include a lightweight composite shell, comfortable interior fit and rear facing vents to prevent dust and dirt from entering the helmet. The Vador also incorporates Bell's fire retardant rubber eyepoint gasket for improved visor seal and natural breath deflector integrated into the chin bar. Designed primarily for use in drag racing, karting and dirt track racing.

- 289 3MM SRV Shield (SRV-1 Pivot Sys) – Clear Shield
- Sizes S (57) to XL (61+)
- Snell SA2015 Homologation

Size.....White.....Matte Bk
S.....BEL1422001.....BEL1422011
M.....BEL1422002.....BEL1422012
L.....BEL1422003.....BEL1422013
XL.....BEL1422004.....BEL1422014
\$529.95

Tear-Offs RAC10211C



GTX.3

It features a lightweight carbon composite shell and sleek aero styling including, front chin bar gurney and integrated rear wing for enhanced aerodynamic performance at higher speeds. The versatile GTX.3 provides industry-leading performance, professional features and is an ideal choice for racers competing in open wheel, open compartment, formula, karting and dirt track forms of racing.

- SE03 3MM DSAF Shield (SV SE03/05 Pivot Sys)
- FIA8859-2015 Homologation

Size.....White.....Matte Bk
7-1/8".....BEL1314001.....BEL1314011
7-1/4".....BEL1314002.....BEL1314012
7-3/8".....BEL1314003.....BEL1314013
7-1/2".....BEL1314004.....BEL1314014
7-5/8".....BEL1314005.....BEL1314015
7-3/4".....BEL1314006.....BEL1314016..... \$729.95

Size.....Carbon

-(7-1/8").....BEL1207001
7-1/8".....BEL1207002
7-1/4".....BEL1207003
7-3/8".....BEL1207004
7-1/2".....BEL1207005
7-5/8".....BEL1207006
7-3/4".....BEL1207007..... \$999.95



Helmet Size Chart		
Std Size.....Inches	Hat Size	
XXXXS.....20-1/16"	6-3/8	
XXXS.....20-1/2"	6-1/2 to 6-5/8	
XXS.....21-1/14"	6-3/4 to 6-7/8	
XS.....22"	7	
S.....22-3/8"	7-1/8	
M.....22-3/4"	7-1/4 to 7-3/8	
L.....23-5/8"	7-1/2	
XL.....24 to 24-3/8"	7-5/8 to 7-3/4	
2XL.....24-3/4"	7-7/8 to 8	
3XL.....25-5/8"	8-1/8 to 8-1/4	
4XL.....26-3/8"	8-3/8 to 8-1/2	

Dominator.2

The legendary Dominator is the most innovative, popular and successful open wheel helmet that Bell has ever produced. It is a worthy successor to the legacy of the original Dominator and is the next evolution in compact, lightweight aerodynamic helmet design and performance. The Dominator.2 incorporates the latest tech and updates while retaining the aggressive and distinctive Dominator styling, this helmet is designed for open wheel, dirt track and kart racers who demand aerodynamic stability, outstanding comfort and fit plus superior ventilation.

- 287 3mm SRV Shield (SRV-1 Pivot Sys) – Clear Shield
- Sizes 7 1/8 (57) to 7 5/8+ (61+)
- Available in White or Matte Black
- Snell SA2015 Homologation



Tear-Offs
RAC10208C

SizeWhite.....Matte Bk
7-1/8" ..BEL1312001.....BEL1312011
7-1/4" ..BEL1312002.....BEL1312012
7-3/8" ..BEL1312003.....BEL1312013
7-1/2" ..BEL1312004.....BEL1312014
7-5/8" ..BEL1312005.....BEL1312015
7-3/4" ..BEL1312006.....BEL1312016.. **.\$829.95**

HP7 Carbon

The FIA8860 homologated, Carbon Fiber HP7 has been developed through close collaboration with leading F1 drivers and teams and as aerodynamically sleek, lightweight and efficient as possible for the intense demands of open-wheel, open-cockpit forms of racing that compete at higher speeds.



Tear-Offs
RAC10237C

- SE07 3MM DSAF Shield (SV SE07 Pivot Sys) Clear
- Sizes 7 1/8 Minus (57-) to 7 5/8 Plus (61+)
- Carbon Finish • Snell SA2015 Homologation
- FIA8860-2015 Homologation

Size.....Bill.....No Bill
6-7/8".....BEL1101001.....BEL1101021
-(7").....BEL1101002.....BEL1101022
7".....BEL1101003.....BEL1101023
+7".....BEL1101004.....BEL1101024
-(7-1/8")..BEL1101005.....BEL1101025
7-1/8".....BEL1101006.....BEL1101026
7-1/4".....BEL1101007.....BEL1101027
7-3/8".....BEL1101008.....BEL1101028
+7-3/8".....BEL1101009.....BEL1101029
7-1/2".....BEL1101010.....BEL1101030
7-5/8".....BEL1101011.....BEL1101031
+7-5/8".....BEL1101012.....BEL1101032.. **.\$3499.95**

GP.2 Youth

It is a fantastic choice for young racers who demand great styling, superior features, light weight and excellent fit in a smaller configuration. It is built specifically for children and younger racers who need a youth helmet that is fire retardant.



- 287 3MM SRV Shield (SRV-1 Pivot System)
- SFI 24.1 (2015) Youth Homologation

Size.Silver.....Flat Black
4XS..BEL1425021.....BEL1425011
3XS..BEL1425022.....BEL1425012
2XS..BEL1425023.....BEL1425013
XS...BEL1425024.....BEL1425014

.\$299.95 \$299.95

Size.White.....Orange
4XS..BEL1425001.....BEL1425031
3XS..BEL1425002.....BEL1425032
2XS..BEL1425003.....BEL1425033
XS...BEL1425004.....BEL1425034

.\$299.95 \$299.95

RS7

Based on the HP7 design and featuring a lightweight carbon composite shell using Bell's high-pressure proprietary molding system, the RS7 uses an innovative shell and shield design to improve acoustic comfort, aerodynamic performance and energy absorbing capacities. The RS7 double screen anti fog (DSAF) visor and rubber gasket seal ensures air, water and dust will not enter the eyeport.



Tear-Offs
RAC10237C

- SE07 3MM DSAF Shield (SV SE07 Pivot Sys) - Clear
- Sizes 7 1/8 (57) to 7 5/8+ (61+)
- Available in White or Matte Black
- Snell SA2015 Homologation
- FIA8859-2015 Homologation

SizeWhite.....Matte Bk
6-3/4" ..BEL1310001.....BEL1310011
6-7/8" ..BEL1310002.....BEL1310012
7".....BEL1310003.....BEL1310013
7-1/8" ..BEL1310004.....BEL1310014
7-1/4" ..BEL1310005.....BEL1310015
7-3/8" ..BEL1310006.....BEL1310016
7-1/2" ..BEL1310007.....BEL1310017
7-5/8" ..BEL1310008.....BEL1310018
7-3/4" ..BEL1310009.....BEL1310019.. **.\$829.95**

RS7 Carbon

SizeNo Bill.....Bill
6-3/4" ..BEL1204021.....BEL1204001
6-7/8" ..BEL1204022.....BEL1204002
7".....BEL1204023.....BEL1204003
-(7-1/8")..BEL1204024.....BEL1204004
7-1/8" ..BEL1204025.....BEL1204005
7-1/4" ..BEL1204026.....BEL1204006
7-3/8" ..BEL1204027.....BEL1204007
+(7-3/8")..BEL1204028.....BEL1204008
7-1/2" ..BEL1204029.....BEL1204009
7-5/8" ..BEL1204030.....BEL1204010
+(7-5/8")..BEL1204031.....BEL1204011.. **.\$1329.95**

Sport EV

The Sport EV, an extended vision helmet with an extra-large eye opening has been designed for the entry level racer who demands value and quality at an affordable price. The all-purpose Sport EV incorporates classic Bell design styling, a wide range of features and is a perfect choice for racers who prefer a wide eyeport or who wear eyeglasses.



Tear-Offs
RAC10205C

- 288 3 mm SRV Shield (SRV-1 Pivot Sys)
- Sizes S (57) to XL (61+)
- White or Matte Black
- Snell SA2015 Homologation

Size...White.....Matte Black
S.....BEL1423001.....BEL1423011
M.....BEL1423002.....BEL1423012
L.....BEL1423003.....BEL1423013
XL.....BEL1423004.....BEL1423014.. **.\$429.95**

HP5 Touring

It is intended for racers in closed car environments who use an external cooling system (not included) and want the added protection of the FIA8860 std. The ultra-versatile HP5 Touring can be used as an all-purpose helmet, with visor peak for closed car racing and with available side and top forced air attachments making it flexible and adaptable to multiple forms of racing.



- SE05 3MM shield (SV SE03/05 Pivot Sys) – Clear Shield
- Snell SA2015 Homo • FIA8860-2015 Homologation

Size.....Carbon Fiber
-(7-1/8") ..BEL1102001
7-1/8" ..BEL1102002
7-1/4" ..BEL1102003
7-3/8" ..BEL1102004
+(7-3/8")..BEL1102005
7-1/2" ..BEL1102006
7-5/8" ..BEL1102007
+(7-5/8")..BEL1102008

.\$2399.95

Sport Mag

The Bell tradition of building high quality open face helmets with classic styling lives on in the Sport Mag. The Sport Mag helmet is designed for racers who enjoy the feel of an open face helmet and demand value and quality at an affordable price.



- Sizes S (57) to XL (61+)
- Available in White, Gloss Black, Safety Orange
- Safety Orange Color Recommended for Boat Racing
- Snell SA2015 Homologation

SizeWhite.....Black
S.....BEL1426001.....BEL1426011
M.....BEL1426002.....BEL1426012
L.....BEL1426003.....BEL1426013
XL.....BEL1426004.....BEL1426014
2XL.....BEL1426005.....BEL1426015
3XL.....BEL1426006.....BEL1426016
4XL.....BEL1426007.....BEL1426017.. **.\$299.95**

KC7-CMR

An ultra-lightweight youth karting helmet based on the HP7 design platform. The sleek, aerodynamic design features an advanced ventilation system with 14 intake and extraction channels that can be used with or without air intake covers to maximize cooling. The RS7 double screen anti fog (DSAF) visor and rubber gasket seal ensures water will not enter the eye opening in rain conditions.



Tear-Offs
RAC10208C

SizeWhite.....Green Graphic
6-1/2" ..BEL1311001
6-5/8" ..BEL1311002
6-3/4" ..BEL1311003.....BEL1311011
6-7/8" ..BEL1311004.....BEL1311012
7".....BEL1311005.....BEL1311013
7-1/8" ..BEL1311006.....BEL1311014
7-1/4" ..BEL1311007.....BEL1311015
7-3/8" ..BEL1311008.....BEL1311016

.\$529.95

Helmet Shields



Type	Clear	Amber	Light Smoke	Dark Smoke	Chrome Blue	Chrome Gold	Chrome Silver
Price	.\$59.95	.\$59.95	.\$59.95	.\$59.95	.\$79.95	.\$79.95	.\$79.95
287 SRV- K.1 Pro, Star GP, Star Infusion, Dominator.2							
GTX.2, GP.2, GP.2 Youth	BEL2010171	BEL2010174	BEL2010172	BEL2010173	BEL2010175		BEL2010176
276 SRV- Vortex GT, K.1 Sport	BEL2010151	BEL2010154	BEL2010152	BEL2010153	BEL2010155	BEL2010157	BEL2010156
281 SRV- M.4, Sport, BR.1	BEL2010161	BEL2010164	BEL2010162	BEL2010163	BEL2010165		BEL2010166
288 SRV- Infusion EV/Sport EV	BEL2010181	BEL2010184	BEL2010182	BEL2010183	BEL2010185	BEL2010187	BEL2010186
289 SRV- Vador	BEL2010191	BEL2010194	BEL2010192	BEL2010193	BEL2010195	BEL2010197	BEL2010196
Price	.\$79.95	.\$79.95	.\$79.95	.\$79.95	.\$79.95	.\$69.95	.\$79.95
M.8 SA2015 (SRV-8) 3mm	BEL2010201	BEL2010204	BEL2010202	BEL2010203	BEL2010205		BEL2010206
Type	Clear	Yellow	Light Smoke	Dark Smoke	Blue Mirror	Gold Mirror	Silver Mirror
Price	.\$79.95	.\$79.95	.\$79.95	.\$79.95	.\$79.95	.\$79.95	.\$79.95
HP7/RS7 Carbon/RS7 Ult(SE07)	BEL2010041	BEL2010044	BEL2010042	BEL2010043	BEL2010047	BEL2010046	BEL2010045
GP.3/GTX.3 (SE03)	BEL2010001	BEL2010004	BEL2010002	BEL2010003	BEL2010007	BEL2010006	BEL2010005

RADIOS



Fusion+ (Plus) 1600 Driver Scanner Only

It is preprogrammed with 1,600 channels for frequencies between 450-470 MHz, and will allow you to manually scan through the channels, 1 or 100 at a time, to the channel that you want to monitor. Or you have the option of finding a driver's channel by simply following the easy to read channel chart. Channel charts are updated weekly and are available on our website or at trackside locations. It is designed to listen to one driver at a time. You can save your favorite driver to the default channel. It utilizes the industry std 3.5 mm jack, allowing the use of a headset. Each RACEceiver Fusion 1600 package contains a RACEceiver, holster, one AAA battery. It is a must for drivers since it allows race officials to broadcast directly to drivers for safety and efficiency purposes without having the drivers talk back.



RCVY1600.....\$99.95

Ace 1600

w/ built in Driver Splitter

It is made to use with a 2-way radio. It has 2 audio ports and takes the audio from the 2-way radio and routes it through the Ace and out so that the driver only has to use one earpiece to listen to both audio sources. It will reduce the volume of the audio from the 2-way radio when the officials are using the frequency and talking to the field, making it much easier to hear the instructions coming from the officials. It comes with a fully enclosed holster, AAA battery, instructions and a 36 mm male to male coiled cord. You may need an addition adapter depending on your 2-way radio set up.

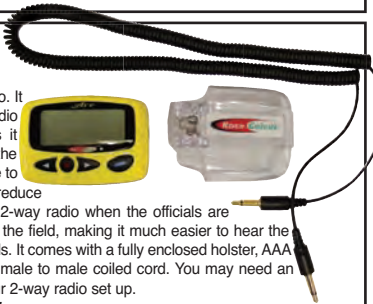

RCVADP1600.....\$109.95

Audible Alert

The Audible Alert wires into the warning lights or sending unit in your race car, sending an audible beep, beep, beep to your ear, through your earpiece, when the oil pressure, water temp, etc., light comes on. The Audible Alert can be used alone or with your RACEceiver or 2-way radio using the helmet splitter that is included in the package. The Mute button allows you to silence the alert for 60 seconds. When the condition is cleared, the alert will reset.



RCVAWI-02.....\$62.95

Helmet Speakers

The soft, padded speakers attach to the inside of your helmet by Velcro pads (included). They have a long section of cable which connects via the jack. The helmet speakers have a standard 3.5mm jack and will work with any MP3, GPS or music device that has this size input.



RCVHS100.....\$29.95

RaceQuip

Snell SA2015 Full Face Helmets

- Fiber Reinforced Polymer (FRP) Hand Laid Shell
- EPS Liner with Nomex Interior
- HANS/HNR M6 Threaded Inserts Installed
- Distortion Free 3mm Polycarbonate Low Fog Shield
- Tear-Off Posts Hand Ratchet to Eight Positions
- Silicone Eyeport Gasket Seals Out Dirt



PRO15



PRO15 Side Air

- PRO15 Full Face (shown)RQP273XXY ...\$219.95
- PRO15 Side AirRQP293XXY ...\$269.95
- PRO15 Top AirRQP263XXY ...\$279.95
- PRO Youth SFI 24.1RQP223XX93 ..\$219.95
- VESTA15 Full FaceRQP283XXY ...\$349.95

Replace XX with = 00 Black, 11 for White, 66 for Gloss Steel, 88 for Hot Pink, 99 for Flat Black, or 35 for Carbon Graphic.

Replace Y with = 0 for XXS, 1 for XS, 2 for SM, 3 for MED, 5 for LRG, 6 for XL, 7 for XXL, and 8 for 3XL.

VESTA15



Clear Case Replacement Enclosed Holder

RCVCASE.....\$7.50



Semi Pro Driver Earpiece - Dual

This stereo earpiece has all the features & performance that you expect from more expensive earpieces. The professional high quality speaker has low distortion & high impedance for clarity. It has a braided cord for durability & foam covers for noise reduction and comfort. It comes with 2 sizes of foam replacements for your convenience.



RCVDE2.....\$49.95

Rookie Driver Earpiece

It is a mid-level stereo earpiece that has terrific sound quality. And it comes with 3 sizes of replaceable rubber tips for a more custom fit. The cord is designed to fall down one side of the body depending on the side you are wearing your audio device.



RCVML100.....\$24.95

Fully Enclosed Car Box

The in-car box was created for those drivers who would like to mount the RACEceiver inside the car. This Box will house your RACEceiver and mount easily inside your car on the roll bar or where you choose. Designed only for the RACEceiver 1600.



RCVCEB1600\$9.95

LAPceiver A.L.T. (Audible Lap Timer) w/ IR Beacon Transmitter

It is a device that allows you to get your lap times in the palm of your hand. You can see the lap times on the large LCD display and hear it audibly using a separate earpiece (not included in the package). You can even choose to have the LapCeiver A.L.T. tell you if the current lap is faster than the previous laps.



Transponder Mode This mode works with a Timing & Scoring System and the transponder that you have on your car. The transponder sends a signal to the Timing & Scoring System that your track is using and a LapCeiver transmitter connected to that system sends the same signal to the LapCeiver A.L.T. You can input the serial number of up to 5 transponders into the LapCeiver A.L.T., one in each of the 5 memory banks. Each memory bank will hold up to 500 laps.

Infra-Red (IR) Mode This mode works with an IR transmitter that is set up across the track. When your car passes through the beam, the Infra-Red Detector, mounted on your car and connected to the LapCeiver A.L.T., detects the beam. It then sends it to the LapCeiver A.L.T., triggering the timing, which shows up on the display. In this mode you use one memory bank at a time. You see your times on the track and you can try different driving styles or different lines to get the quickest times. Times are stored and can be recalled once you are back in the pits.



Audible Lap Timer.....RCVLAP-IRT-101PK.....\$199.50

Lap TimerRCVLAP\$call

Beacon Transmitter.....RCVIRT-101PK.....\$call

SA2015 Vesta 15 Carbon Fiber

RaceQuip's Vesta 15 Carbon Fiber Snell SA-2015 helmets are unique and opposite from traditional auto racing helmet styling. These innovative new helmets feature a uniquely shaped chin bar to support a scalloped faceshield design. Fire Retardant Paint & Interior. Sizes Small To 2X-Large.



RQP921390.....\$599.95

SFI-1 and SFI-5 Suits, Jackets, & Pants

Exceeds SFI 3.2A/1 or 3.2A/5 Ratings. Pyrovatex FRC and Moex Construction. Fresh, Stylish Designs. Black Epauletes, Belt, and High Back Collars. Pleated Back Panel for Flexibility. Boot Cuff Pant Legs



- SFI-1 Single Layer 1 pc Suit.....RQP110XXY ...\$99.95+
- SFI-1 Single Layer JacketRQP111XXY ...\$59.95+
- SFI-1 Single Layer Pants.....RQP11200Y ...\$59.95+
- SFI-5 Multi Layer 1 Pc Suit.....RQP120XXY ...\$259.95+
- SFI-5 Multi Layer Jacket.....RQP121XXY ...\$149.95+
- SFI-5 Multi Layer Pants.....RQP12200Y ...\$139.95+
- SFI-1 Youth/Jr. Suits, Jackets, and Pants also available.

Replace XX with = 00 Black, 10 for Red, 02 for Blue.

Replace Y with = 2 for SM, 3 for MED, 4 for MED TALL, 5 for LRG, 6 for XL, 7 for XXL, 8 for 3XL, 9 for 4XL, and 0 for 5XL.

SFI Rated Nomex Gloves

1 Layer or 2 Layer Nomex Knit Construction. High Grip Suede Leather Reinforced Palm. Colors: Black, Red, Blue w/ Grey or Black Suede. Soft, Supple, & Comfortable.



- SFI-1 Single LayerRQP351XXY ...\$39.95
- SFI-5 Double LayerRQP355XXY ...\$49.95
- SFI-5 Double Lyr YouthRQP355009Y ..\$49.95
- SFI-5 2 Lyr Long Angle Cut.....RQP358XXY ...\$59.95
- SFI-5 2 Lyr Long Outseam.....RQP359XXY ...\$69.95
- SFI-5 2 Lyr Outseam w/Elastic.....RQP356XXY ...\$69.95

Replace XX with = 00 Black, 01 for Red, or 02 Blue.

Replace Y with = 1 for XS, 2 for SM, 3 for MED, 5 for LRG, 6 for XL, 7 for XXL, and 8 for 3XL.

Basic Race Shoe



SFI Rated Racing Shoes

Suede Leather Upper. Pyrovatex Flame Retardant Liner. Molded Flexible Rubber Sole. Padded Ankle and Arch Support. Euro Shoe features Carbon-L Wear Pads.



Euro Carbon-L Shoe

Basic Race Shoe (Full Sizes 8-13)RQP30300YYY ...\$69.95

Euro Carbon-L Shoe (Half Sizes 1-20)RQP30500YYY ...\$89.95+

All shoes are Black, replace YYY with 3 digit size like 080, 085, 090, 100, 105, 110, 115, 120, etc.

Motorola MagOne Stingray System

Short Track 2-Man System
* Helmet not included.

Complete 2 Man System
RAERE840.....\$899.95

For the Car:

- Motorola BPR40 Radio
- RE4302 Legacy Harness
- RE503 Legacy PTT Switch
- RB-3 Radio Mounting Kit

For the Crew Chief:

- Motorola BPR40 Radio
- RE005 Legacy Headset
- RE3736 Radio Interface Cable

For the Driver:

- RE1 Foam Earmolds
- RE705 Legacy Flex Boom Helmet Kit



Motorola Stingray Extra Crew

- Motorola BPR40 Radio
 - RE005 Legacy Headset
 - RE3736 Radio Interface Cable
 - RaceBELT
- RAERE841.....\$399.95



Car Harness



Universal Harness

(requires radio interface cable)
9' Cable • BNC Style Connector
RAERE4005..\$98.95

Legacy Harness

Fits Kenwood/Reliant
RAERE4909.....\$119.95

Splitter Cord

Share your scanner and the excitement! Our 1/8" 2-way splitter fits most popular scanners.
RAERE-66.....\$12.14

Standard Open Face

Legacy open face stock car metal helmet kit. Noise Canceling Mic.
RAERE504.....\$79.76

Compact Flex Boom

RaceTRAC legacy stock car flex boom helmet kit. Noise Canceling Mic.
RAERT605.....\$179.95

Legacy Harness

This Legacy stock car harness will work with the following radios:
GP300, SP50, P110, P1225, GTX, CP150, CP200, CT150, CT250, CT450, PR400, GP2000, GP308, GP68, SP10, SP21, GP350
(requires a HLN9482 adapter)
RAERE4302.....\$119.95

Standard Flex Boom (features Std MIC)

Stock Car Style 3-Conductor Straight Cord
RAERE705.....\$109.95



Radio Box

The swivel mount keeps your box vertical on nearly any bar and Joe's quality protects your investment from damage and vibration in a lightweight package that mounts in seconds. Boxes measure 5" x 3-3/4" x 2-1/2".
1-1/2" clamp..JOE11312..\$47.95
1-3/4" clamp..JOE11314..\$47.95



Push to Talk Switches

(velcro mounted)

Push to Talk (PTT) Switches

RaceTRAC Hole Mt thru the Wheel
RAERT403.....\$89.95

David Clark PTT

RAERT603.....\$149.95

RaceTRAC Platinum PTT

RAERE703.....\$89.95

Legacy PTT

RAERE503..\$59.95

Antennas

Thick Roof Mount

9' Cable • BNC Style Connector
RAERT711-U.....\$89.95

Roof Mount

9' Cable • BNC Style Connector
RAERE511-U.....\$69.95

Car Antennas

3db Phantom Antenna
RAERT311-U..\$99.95

Earmolds

Foam Race Mold

These foam earmolds are great for fans or drivers. Just roll these high quality ear foams between your fingers and fit down into your ears and you will be able to hear great without any bulky headset.
RAERE1.....\$101.44

Semi Custom Race Mold

These earmolds are great for the super speedway race-fan or the Friday night racer. Comfortable and clear. Highest Quality!
RAERE2.....\$128.95

Replacement foam covers

RAEBUNS1..\$2.95

SOLO-3 Miniature 1600 UHF Frequency Receiver

- Track Legal
 - Micro Receiver (2.45"W x 1.68"H x .75"D)
 - 1600 UHF Frequencies
 - 2 Channels
 - 2-Way Radio Interface
 - Module
 - Clear Acrylic Clip Case
 - 1 Year Warranty
- RAERE-SOLO-3.....\$99.95

Mounting Boxes

(For In-Car) Sturdy Alum. Radio Mounting Box

RAERB-4...\$39.95

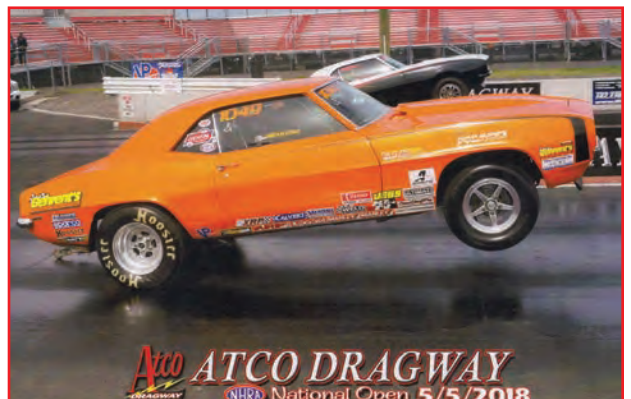



GP Race Suit

Certified to FIA and SFI homologation standards, the GP Race Suit features a fully floating arm construction and elasticated stretch panel on the back for excellent, anatomical performance fit. Light, close-fitting and featuring an Aramidic three-layer construction this suit is supremely comfortable. Certified to FIA 8856-2000 & SFI 3.2A Level 5 homologation std. 100% Aramidic outer layer with twin Aramidic internal layer for max heat transfer protection. Aramidic reinforced, elasticated lower back panel for unrestricted movement. Anatomical arm, leg and torso paneling patterned for optimum driving position fit. Internal flat seams reduce pressure points in the suit for a more comfortable driving experience. Close-fitting design and adjustable collar and belted waist for precise fit. Floating arm construction for unrestricted performance. Alpinestars shoulder epaulette construction to facilitate effective extraction of driver in event of a crash. Ribbed, stretchable wrist cuff and boot leg cuff for excellent comfort and fit. Anatomical thigh pockets for convenient, unobtrusive storage. Sizes: 44-60.

ALP3355117.....\$699.95

GP Delta Suit

Certified to FIA (FIA: 8856-2000 No: RS.285.16) and SFI (SFI: 3.2A/5) Standards. Advanced 2 layer construction for weight saving and improved heat resistance performance. 100% aramidic outer layer provides excellent resistance to heat, plus aramidic lining for maximum heat transfer protection. Anatomical arm, leg, and torso paneling patterned for optimum driving position fit. Internal flat seams reduce pressure points in the suit for a more comfortable driving experience. Fully floating arm construction to facilitate effective extraction of driver in event of a crash. Ribbed, stretchable wrist and foot cuff helps keep suit in position while driving. Sizes: 44-60 (44-64 in Black)

ALP3355617.....\$549.95

Knoxville Boot Cut Suit

The Knoxville Suit is ergonomically profiled for a close-fitting performance fit with a boot cut leg construction. As well as incorporating excellent safety features and innovative materials, the Knoxville is certified to SFI standards, and is lightweight and anatomically optimized. Certified to SFI Level 3.2 A/5 standard. Advanced two-layer construction for weight saving and comfort in the cockpit. 100% Aramidic outer layer provides excellent resistance to heat. Aramidic lining for maximum heat transfer protection. Anatomical arm patterning for optimum driving position fit. Internal flat seams reduce pressure points in the suit for a more comfortable driving experience. Fitted design and adjustable collar and elasticated waist for precise and secure fit. Boot cut leg construction for comfort while driving. Alpinestars shoulder epaulette construction to facilitate effective extraction of driver in event of a crash. Unobtrusive thigh pockets for convenient storage. Sizes: 44-66.

ALP3355916.....\$399.95

Suit	GP Race	Delta	Knoxville
Main Construction.....	2 Layer	2 Layer	2 Layer
Main Assembly Weight.....	380 gsm	380 gsm	410 gsm
Breathability	Good	Good	Average
Full Floating Armhole	Yes	Yes	No
Arms & Leg Anatomically Designed	Yes	Yes	No
Internal Flat Seams Constructions	Yes	Yes	Yes
Lumbar Stretch Panel	Yes	No	No
Fit	Athletic	Regular	Comfort
Driving Experience	Advanced	Comfort	Beginner

Size	Neck	Chest	Waist	Hip	Inseam	Outer Arm	Height	US Pant Size
40	13.8"	30 3/4 - 32 1/4"	25 1/4 - 26 3/4"	31 1/8 - 32 5/8"	28" - 28 3/4"	19 1/4 - 20 1/8"	4' 11" - 5' 1"	24
42	14.2"	32 1/4 - 33 7/8"	26 3/4 - 28 3/8"	32 5/8 - 34 1/4"	28 3/4 - 29 1/8"	20 1/8 - 20 3/4"	5' 2" - 5' 4"	26
44	14.6"	33 7/8 - 35 3/8"	28 3/8 - 29 7/8"	34 1/4 - 35 7/8"	29 1/8 - 29 7/8"	20 7/8 - 21 1/4"	5' 4" - 5' 5"	28
46	15"	35 3/8 - 37"	29 7/8 - 31 1/2"	35 7/8 - 37 3/8"	30 3/8 - 30 3/4"	21 5/8 - 22"	5' 6" - 5' 7"	30
48	15.4"	37" - 38 5/8"	31 1/2 - 33 1/8"	37 3/8 - 39"	31 1/8 - 31 1/2"	22 1/2 - 22 7/8"	5' 7" - 5' 8"	32
50	15.7"	38 5/8 - 40-1/8"	33 1/8 - 34 5/8"	39" - 40 1/2"	31 7/8 - 32 1/4"	23 1/4 - 23 5/8"	5' 9" - 5' 10"	34
52	16.1"	40 1/8 - 41 3/4"	34 5/8 - 36 1/4"	40 1/2 - 42 1/8"	32 5/8 - 33 1/8"	24" - 24 3/8"	5' 11" - 6"	36
54	16.5"	41 3/4 - 43 1/4"	36 1/4 - 37 3/4"	42 1/8 - 43 3/4"	33 1/2 - 33 7/8"	24 3/4 - 25 1/4"	6" - 6' 2"	38
56	16.9"	43 1/4 - 44 7/8"	37 3/4 - 39 1/4"	43 3/4 - 45 1/4"	34 1/4 - 34 5/8"	25 5/8 - 26"	6' 2" - 6' 3"	40
58	17.3"	44 7/8 - 46 1/2"	39 1/4 - 41"	45 1/4 - 46 7/8"	35" - 35 3/8"	26 3/8 - 26 3/4"	6' 3" - 6' 5"	42
60	17.7"	46 1/2 - 48"	41" - 42 1/2"	46 7/8 - 48 3/8"	35" - 35 3/8"	26 3/8 - 26 3/4"	6' 3" - 6' 5"	44
62	18.1"	48" - 49 5/8"	42 1/2 - 44 1/8"	48 3/8 - 50"	35 7/8 - 36 1/4"	27 1/8 - 27 1/2"	6' 5" - 6' 6"	46
64	18.1"	49 5/8 - 51 1/8"	42 1/8 - 45 5/8"	50" - 51 5/8"	35 7/8 - 36 1/4"	27 1/8 - 27 1/2"	6' 5" - 6' 6"	48



ZX EVO Long Sleeve Top/Bottom

FIA Approved SFI 3.3/5

Alpinestars ZX Series EVO layers are constructed with Lenzing FR®; an innovative natural viscose fiber that affords exceptional flame resistance and protection against heat transfer. This Formula 1 specification underwear is extremely lightweight and thin, while being incredibly soft to the touch for greatly enhanced comfort when wearing a driving suit.

- Top - Black.....ALP4755216-106\$159.95
- Bottom - Black.....ALP4755716-106\$139.95
- Top - White.....ALP4755216-201\$159.95
- Bottom - White.....ALP4755716-201\$139.95



Race Long Sleeve Top/Bottom

FIA Approved SFI 3.3/5

Lightweight materials offering high breathability and flame-resistance properties, the Race Tops and Bottoms are Formula 1 specification underwear that incorporates a relaxed fit for comfort when wearing a driving suit.

- Top - Black.....ALP4754516-12B\$134.95
- Bottom - Black.....ALP4754716-12B\$114.95
- Top - White.....ALP4754516-21F\$134.95
- Bottom - White.....ALP4754716-21F\$114.95



ZX EVO Head Sock FIA Approved SFI 3.3/5

Alpinestars ZX Series EVO layers are constructed with Lenzing FR®; an innovative natural viscose fiber that affords exceptional flame resistance and protection against heat transfer. This Formula 1 specification underwear is extremely lightweight and thin, while being incredibly soft to the touch for greatly enhanced comfort when wearing a driving suit.

- Head Sock - BlackALP4754916-10-O/S ..\$79.95
- Head Sock - White.....ALP4754916-20-O/S ..\$79.95



Race Head Sock FIA Approved SFI 3.3/5

Lightweight materials offering high breathability and flame-resistance properties, the Race Balaclava is a Formula 1 specification piece that incorporates a relaxed fit for comfort when wearing a racing helmet.

- Head Sock - BlackALP4754816-10-O/S ..\$64.95
- Head Sock - White ..ALP4754816-20-O/S ..\$64.95



ZX Sock FIA Approved

Advanced ZX underwear series socks developed by Alpinestars. Complies with FIA8856-2000 homologation standard. Special material formulation offers more breathability than standard Nomex. Lightweight, seamless construction designed to reduce pressure points. Fabric is extremely soft to the touch and flexible for enhanced comfort. Lenzing FR material is a special natural viscose fiber with unique thermal insulation and permanent flame resistance properties that help prevent heat stress.

- Sock - Black
- Sock - White



Nomex Sock FIA Approved

FIA 8856-2000 Approved. Seamless construction. Knee length.

- Sock - Black
- Sock - White.....



Tech 1-Start Racing Gloves SFI 3.3/5

Extremely lightweight and comfortable, the Tech 1 Start Glove features ergonomic suede inserts for excellent grip response while the Nomex® main shell offers high levels of heat and flame resistance. The Tech 1 Start is homologated to FIA and SFI standards.

ALP3551617.....\$84.95



ALP3551617-30-

ALP3551617-10-

ALP3551617-70-



ALP3551117-12-

ALP3551117-155-

ALP3551117-156-

ALP3551117-231-

ALP3551117-551-

Tech 1-Race Gloves SFI 3.3/5

Certified to SFI and FIA homologation standards, the aggressively styled Alpinestars Tech 1 Race Glove features minimal seam construction, optimized levels of grip via a newly extended silicone printed full palm and finger areas, as well as a pre-curved finger structure to aid fit, reduce fatigue and offer excellent feel sensitivity and fit. Sizes: S-XXL.

ALP3551117.....\$119.95



ALP3551117-167-



ALP3550217-1155-

ALP3550217-132-

ALP3550217-12-

ALP3550217-967-

ALP3550217-1091-

Tech 1-Z Racing Gloves SFI 3.3/5

Drawing on decades of technical expertise from Alpinestars' racing program, the Tech 1-Z Glove features an ergonomically evolved chassis design, an innovative finger construction and new extended silicone grip patterning to deliver supreme lever control, comfort feel sensitivity and performance. Constructed from Nomex® and a flame-resistant lining the Tech 1-Z ensures excellent levels of protection against the build-up of heat.

ALP3550217.....\$149.95



ALP3550317-1431-

ALP3550316-17-

ALP3550317-1045-

ALP3550317-12-

ALP3550317-718-

Tech 1-ZX Racing Gloves SFI 3.3/5

Complying fully with FIA and SFI homologation standards Alpinestars' premium auto racing glove, the Tech 1-ZX, features an innovative Nomex® construction with minimal seam stitching and reduced material construction to offer superior levels of performance, cockpit comfort and sensitivity on the car's controls. An ergonomically evolved chassis design and new extended silicone grip patterning offers excellent fit and grip where and when it is most needed.

ALP3550317.....\$199.95



ALP3550317-1042-

	Tech.....	Tech.....	Tech.....	Tech.....
Gloves	1-ZX	1-Z	1-Race	1-Start
Assembly w/Thinner Bonded Fabric	Yes	Yes	Yes	Yes
New Fit	Yes	Yes	Yes	Yes
Weight Saving Due to New Construction	Yes	Yes	Yes	Yes
Precurved	Yes	Yes	Yes	No
Outside Stitching	Yes	No	No	No
Inner Stitching	No	Yes	Yes	Yes
Inside Palm Latex Sprayed	Yes	Yes	No	No
Printed Silicone Palm	Yes	Yes	Yes	Yes
Heat Transfer Graphic	Yes	Yes	Yes	Yes
Thinner Seams on the Wrist	Yes	Yes	Yes	Yes
Driving Experience	Superior	Excellence	Advanced	Comfort



ALP2710618-12-(size)

ALP2710618-713-(size)

ALP2710618-31-(size)

SP Racing Shoes

Designed and constructed to offer excellent levels of breathability and performance fit, the SP Shoe is extremely comfortable, both in and out of the car. It is derived from Alpinestars F1 racing development program to deliver both enhanced feel and grip of the pedals. It is certified to FIA 8856/2000 homologation stds. Main upper constructed from premium suede for optimum levels of durability, comfort and fit. Full tongue upper, lateral and medial constructed from perforated suede for enhanced ventilation and optimized breathability. It features multi-compound construction and ergonomic polypropylene heel counter, which provides support, protection and stability plus integrated PU fireproof heel for comfort. LW micro-porous padding around the heel and insole enhances comfort. FIA label on the tongue made from fireproof TPR. Logos & graphics are embroidered.

ALP2710618.....\$199.95



ALP2710115-104-(size)

ALP2710115-119-(size)

ALP2710115-1519-(size)

ALP2710115-7210-(size)

ALP2710115-1241-(size)

ALP2710115-199-(size)

Tech 1-T Racing Shoes

Incorporating premium materials - inside and out - the Tech 1-T is an extremely lightweight, abrasion-resistant shoe that offers superb comfort features and performance. It incorporates a weight-saving, rubber-compound textured sole for outstanding grip, heel-to-toe feel and vibration resistance. It is certified to FIA homologation standards. Main upper constructed from durable, full-grain leather for optimized levels of durability, comfort and abrasion resistance. Strategically positioned perforation zones for enhanced cooling performance and max airflow. Dual closure system incorporates adjustable Velcro strap plus lace loop system for durability, personalized fit and secure closure. Nomex tubular lining construction for excellent heat-resistance, weight-saving and reduced seams. Lightweight rubber compound sole with textured grip and improved pedal feel in race conditions. It features multi-compound construction ergonomic polypropylene heel counter, which provides support, protection and stability plus an integrated PU fireproof heel for comfort. Lightweight micro-porous padding around the heel and insole enhances comfort. FIA /Alpinestars label on the tongue made from fireproof TPR. All graphic elements are printed for weight-saving.

ALP2710115.....\$269.95



ALP2715115-104-(size)

ALP2715115-123-(size)

ALP2715115-237-(size)

ALP2715115-1045-(size)

ALP2715115-167-(size)

ALP2715115-21-(size)

Tech 1-Z Racing Shoes

Incorporating advanced performance technologies and premium materials such as kangaroo leather, the extremely lightweight Tech 1-Z features streamlined foot-shaping, extensive perforation zones and Alpinestars' exclusive rubber compound sole for superb levels of comfort and maneuverability in the confines of the cockpit. The Tech 1-Z shoe is certified to FIA 8856/2000 homologation standards. Lightweight micro-porous padding around the heel and foot bed enhances comfort. All graphic elements are printed for weight-saving and improved performance. Low-cut collar in heel to allow for greater Achilles heel comfort and improved range of movement. Collar padding constructed from Nitrile rubber for comfort and weight-saving. Tongue padding made in double layer CarbonX material for additional flame-retardant properties, plus reduced weight. FIA /Alpinestars label on the tongue made from fireproof TPR.

ALP2715115.....\$329.95

		Driving Shoe Size Chart												
US		5	6	7	7.5	8	8.5	9	9.5	10	10.5	11	12	13
Euro		37	38	39	40	40.5	41	42	42.5	43	43.5	44	45.5	47

Shoes	Tech 1-Z	Tech 1-T	SP
Assembly	Kangaroo Leather	Full Grain Leather	Suede
Closure System	Speed Top Lacing	Conventional	Conventional
Dual Closure Sys Inc Adj Velcro Strap	Yes	Yes	No
1-Piece Foot & Heel Counter	Yes	No	No
Rounded Heel	Yes	Yes	Yes
Perforated Leather	Yes	Yes	No
Printed Graphic Element	Yes	Yes	No
Additional Lateral Protection	No	Yes	No
Driving Experience	Excellence	Advanced	Comfort

Steps to Buying a **hans**

• Step 1: Pick degree you need

Model 10 - Extreme Upright Seat: Fits many Sprint cars. Fits many people weighing under 75 lbs. in an upright seat. If you sit very upright & cannot get comfortable with a Model 20 try this Model.

Model 20 - Upright Seat: Fits all sedans including NASCAR, Busch, Sprint, Midget, Quarter Midget, Drag, Modified, Bandalero & similar. All sportscars including Porsche, BMW, Corvette, Honda, Viper etc. All Panof Racing Series cars. Marine apps including UIM & Drag Boats. **NOTE:** Drivers over 200 lbs. may find a Model 30 more comfortable in vehicles listed above.

Model 30 - Semi Reclined Seat: Fits Formula Mazda, Atlantic, Infiniti Pro, Barber Dodge, IRL, C/D Sports Racer, Formula 1 and similar.

Model 40 - Recylined Seat: The Model 40 is a rare application and fits extremely reclined seats such as Vintage Formula Ford and Bonneville cars. Please measure your seat (use an angle meter available at DIY-type stores) before ordering.

• Step 2: Neck Size

Hans Device Sizing Chart

Neck size is the starting point for fitting.

11" 12" 13" 14" 15" 16" 17" 18" 19" 20"



Hans III

The HANS III represents the third generation of injection molded HANS devices and features a contemporary approach to reducing weight. Using an all new design and polymer, the device features a hollow collar that substantially minimizes weight. Engineered reinforcements ensure an exceptionally strong structure that provides the same level of safety as every HANS device. The reduced mass guarantees the lightest and most comfortable injection molded HANS ever.

Size	Post Anchor	Quick Click Release
Medium	HANDK14237.311SFI..	\$449.00
Large	HANDK14247.311SFI..	\$449.00



Hans Sport III (Youth)

The SFI 38.1 certified, HANS III Youth features a hollow collar that substantially minimizes weight and is engineered for the growing young racer. Reinforcements ensure an exceptionally strong structure that provides the same level of safety as every HANS device.

Size/Anchor/Tether	2010 Snell Helmets	2015 Snell Helmets
20Y/Post Anchor/Sliding	HANDK16217.321SFI..	\$429.00
20Y/Quick Click/Sliding	HANDK16217.421SFI..	\$429.00

Hans Adjustable Series

"Adjust your Hans for any degree to use in multiple applications!"

The HANS Adjustable, which meets the SFI Foundation's Spec. 38.1 for head and neck restraints, enables all drivers to purchase a HANS with full confidence of a comfortable fit no matter what type of car or racing seat they use.

Hans Adjustable

Size/Anchor/Tether	2010 Snell Helmets	2015 Snell Helmets
Med/Post Anchor/Sliding	HANDK13034.32SFI..	\$549.00
Lrg/Post Anchor/Sliding	HANDK13044.32SFI..	\$499.00

Med/Quick Click/Sliding	HANDK13034.42SFI..	\$549.00
Lrg/Quick Click/Sliding	HANDK13044.42SFI..	\$549.00

*Adjusts from 10 to 40 Degree for all forms of racing.



Hans Pro Ultra Carbon Fiber Lightweight

Size/Anchor/Tether	2010 Snell Helmets	2015 Snell Helmets
20M/Post Anchor/Sliding	HANDK13235.32SFI..	\$979.00
20L/Post Anchor/Sliding	HANDK13245.32SFI..	\$979.00

20M/Quick Click/Sliding	HANDK13235.42SFI..	\$979.00
20L/Quick Click/Sliding	HANDK13245.42SFI..	\$979.00

Snell SAH2010 helmets have a threaded insert (nutwasher) bonded directly inside the helmet shell. Anchors for these helmets are sold without nutwashers. These anchors use an indexing collar instead of a post and include a tool to orient or index the anchor from the outside of the helmet shell.



Hans Post Collar Anchor



Professional Series

With Aluminum Base
SAH Helmet
SA Helmet

Nutwasher Backing

Nuts Set of 2
HANK9115

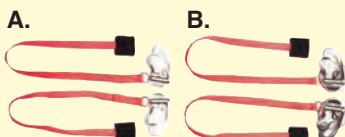

Quick Click Attachment Fits SAH Helmet

A.) SAH Helmet
Without Nut Washer

Fits SA Helmet

B.) SAH Helmet

Sliding Tether for Post Collar Anchor

Sport II (Shown)
Sport I, Professional
Adjustable, Pro Ultra
Hans III



Sliding Tether for Quick-Click Anchor

Sport II (Shown)
Sport I, Professional
Adjustable, Pro Ultra
Hans III



Padding (Socks Only)

Gel Padding Kit



Foam Pad

K9005-Black, K9007 - Blue, K9024 - Red, K9008 - Blue.

Hybrid Sport

The Hybrid Sport is a great head restraint device for those racing on a budget. The Hybrid Sport with it's new light-weight design and DuPont carbon /polymer construction provides maximum comfort and maneuverability with superior strength. All of Simpson's Hybrid Series head restraints are designed for easily exiting the car without danger of being entangled in other gear by offering the lower profile of any comparable devices. The device comes with optional patented SAS(Seatbelt Anchor System)for even greater coverage in flips and barrel rolls. When the worst happens, you'll have the same great protectoin every time.

- Available with patent pending multi-tether system to enhance side to side movement
- DuPont carbon polymer construction - QR Tethers and D-Ring kit as standard.
- Sleek, modern profile with defined wings for seatbelt containment
- We can further customize your Hybrid Sport with any of the following options. The Seatbelt Anchor System is encouraged for drivers in markets such as Sprint cars and provides more stability to the driver in flips and barrel rolls.
- Dual End tethers and M6 Anchors or Post Clip Tethers & Post Anchors, Additional \$65.
- Seat Belt Anchor System is available with all tether systems. Additional \$40.



Hybrid Sport

Size	QR + D-Ring	PA
Child (4-6 yrs old)	SIMHS.XSC.11..\$399.00.	SIMHS.XSC.11.PA..\$464.00
Child (7-9 yrs old)	SIMHS.CHD.11..\$399.00.	SIMHS.CHD.11.PA..\$464.00
Youth (9-12 yrs old)	SIMHS.YTH.11..\$397.00.	SIMHS.YTH.11.PA..\$464.00
X-Small	SIMHS.XSM.11..\$598.95.	SIMHS.XSM.11.PA..\$664.00
Small	SIMHS.SML.11..\$594.50.	SIMHS.SML.11.PA..\$664.00
Medium	SIMHS.MED.11..\$599.00.	SIMHS.MED.11.PA..\$664.00
Large	SIMHS.LRG.11..\$599.00.	SIMHS.LRG.11.PA..\$664.00
X-Large	SIMHS.XLG.11..\$586.95.	SIMHS.XLG.11.PA..\$664.00

Hardware	Price
QR + D-Ring	SIMFSI.DRK\$27.00
PA	SIMPA.HAK.....\$70.00
M6 Hemet Anchor SFI 38.1 Certified	SIMM61.HAK.....\$70.00
M6 Hemet Anchor SFI 38.1 Certified SAH	SIMM61.HAK.SAH...\$65.00

*Add SAS for Seat Belt Anchor System

JR. Sizes	Smallest Adjustment	Largest Adjustment
X-Small Child (4-6 yrs old)	22"	26"
Child (7-9 yrs old)	22"	26"
Youth (9-12 yrs old)	26"	30"

Adult Sizes	Smallest Adjustment	Largest Adjustment
X Small	32"	36"
Small	36"	40"
Medium	40"	44"
Large	44"	48"
X-Large	48"	52"



NecksGen Rev2Lite

The REV 2 LITE is the ultimate head and neck restraint. Weighing in at only 1.2 lbs. / 550 grams, the REV2 LITE carries the same level of protection and certifications as the NecksGen Original and REV devices. The REV2 LITE has all the same features as the REV, but adds a clever new adjustable tether system, rubber grip friction pads to help you feel locked in your seat better, higher belt guides to keep everything locked in place and for multiple impact situations. The shoulder pads are improved, and as an exclusive new feature, the REV2 LITE comes with free recertifications.



NecksGen Unit	Price
NecksGen "REV" Device - Medium	NECNG501 ..\$569.00
NecksGen "REV" Device - Large	NECNG502 ..\$569.00

Sizing the REV is fairly simple if you use this handy chart. Remember that fitment is based on personal preference, and sizing isn't necessarily limited to the measurements shown. If your neck is wider than the inside dia of the device shown, the device could still fit, and will function properly, but some comfort will be sacrificed. If you are on the edge between a medium and a large but have narrow shoulders, go with the medium.

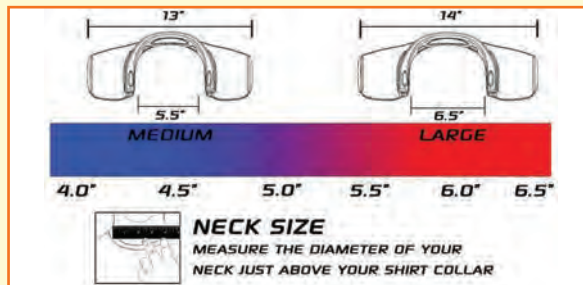

NecksGen Rev

NecksGen's commitment to keeping racers safe by providing the most technologically advanced, Frontal Head Restraints (FHR) on the market! This radical departure from conventional designs, exemplifies simplicity and un-needed mass to provide the user with the utmost comfortable and light-weight device, without compromising safety. The device has been tested by SFI laboratories and is certified to be manufacturer's compliant to the SFI 38.1 specification, making it approved for use by most sanctioning bodies.



NecksGen Unit	Price
NecksGen "REV" Device - Small	NECNG23 ..\$399.00
NecksGen "REV" Device - Medium	NECNG21 ..\$499.00
NecksGen "REV" Device - Large	NECNG20 ..\$499.00
"REV" Quick Release Hardware	NECNG27 ..\$79.00
Replacement Pad w/velcro	NECNG261 ..\$39.15

Sizing the REV is fairly simple if you use this handy chart. Remember that fitment is based on personal preference, and sizing isn't necessarily limited to the measurements shown. If your neck is wider than the inside dia of the device shown, the device could still fit, and will function properly, but some comfort will be sacrificed. If you are on the edge between a medium and a large but have narrow shoulders, go with the medium.

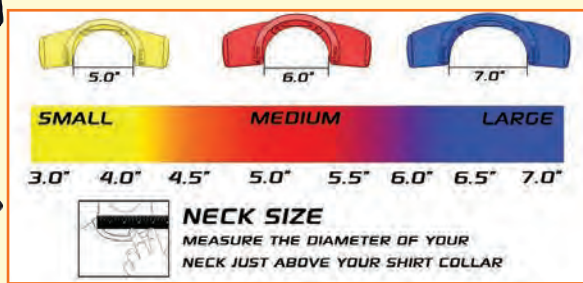

Impact Accel Frontal Head Restraint

The Impact Accel offers unparalleled comfort combined with the ultimate in frontal and angular impact protection. Affordably priced and adjustable, the Impact Accel is your go-to safety device regardless of seat angle or complement of motorsports. Constructed from light-weight yet durable DuPont carbon composite material, the Accel can withstand the rigors of nightly racing whether you compete in drag, circle track or off-road. Includes helmet hardware, no need to purchase separate FHR posts for your helmet!

- Adjusts Between 10-40 Degrees for a Variety of Uses.
- Weighs Less than 2 Pounds (1.8 Pounds or 816.5 Grams).
- Body Forming Shoulder Pads offer Unparalleled Comfort.
- Offers Superior Angular Impact Protection & SFI 38.1 Compliant.
- Made from Carbon Fiber DuPont Composite Materials.
- Includes helmet hardware. FHR posts for your helmet.

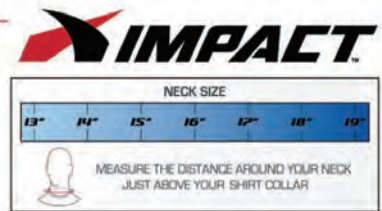

Std Size w/Quick Release & D-Ring	IMP92000499 ..\$536.00
-----------------------------------	------------------------

HELMETS



Call for Helmet Specials!

GF3

Tear-Offs
RAC10205C

- Rating: SNELL SA2015
- LW Composite Shell
- Flame Retardant
- Reinforced mounting points for Helmet Restraint Devices.
- Sizes: XS- XXL
- Colors, BK, WH, MB



A time tested baseline design from G-FORCE Racing Gear, the GF3 is the benchmark in quality, functionality and style. From the outside in you will notice the difference. The outer contact shell is made from a low density, lightweight composite blend. The shell is then coated with deep, rich white, gloss black or matte black paint and finished with a protective clear coat outer layer. The rear of the helmet is accented with double ridge lines that add both style and strength to the GF3 shell. Reinforced mounting points for all SFI approved Restraint Devices are built into the shell during production for added durability. An optically correct, .125" thick, ProFit Shield encloses the extra wide eye port opening and secures to the rubberized, eye port gasket to keep dust and dirt out. The ProFit Shield is help in place by two aircraft aluminum, wide-head bolts for easy change-out and removal. The thumb indentation makes lifting the shield, even with gloves, simple and clean. The pivot kit contains 5 shield ratchet positions so that the driver can adjust to their liking.

GF3GFO3123.....\$249.99

GF7 Side Air

2015 Helmet with a sleek new design from G-Force Racing, the GF7 Full Face has provided a new benchmark in quality, functionality and style. From the outside in you will notice the difference. The outer contact shell is made from a low density, Z38 lightweight composite blend. The shell is then coated with deep rich white gloss paint and finished with a protective clear coat outer layer. The rear of the helmet is accented with double ridge lines that add both style and strength to the GF7 Full Face's shell.

GF7 Side Air.....GFO3127WH.....\$199.99



Carbon Fiber

CF3 Carbon Fiber Low Price!

- Rating: SNELL SA2015
- Carbon Fiber Composite Shell
- Flame Retardant Liner
- G-79 Impact Liner with Conehead Technology
- G-FLOW Ventilation System
- Reinforced mounting points for Helmet Restraint Devices.
- Sizes: S-XXL • Colors, BK

Tear-Offs
RAC10205C

A new take on the previous design carbon fiber helmet from G-FORCE Racing Gear, the CF3 is the new standard in functionality and style. From the outside in you will notice the difference. The outer contact shell is made with a ultra-lightweight, Carbon Fiber and composite blend which weighs 15-20% less than standard models. The shell is then coated with deep, rich protective clear coat outer layer. The CF3 outer layer is also accented with a muted, matte black racing stripe with pinstripe outer borders down the center. The rear of the helmet is accented with double ridge lines that add both style and strength to the CF3 shell.



CF3GFO3128.....\$349.99

GF1

- Rating: Snell SA2015
- LW Composite Shell
- Flame Retardant
- G-FLOW Top/Rear Vents
- Reinforced Mounting Points for Head & Neck Restraint Devices
- Kevlar Chinstrap
- Impact Liner made with Conehead Technology
- Sizes: S-XXL • Colors: BK, WH

GF1 open face helmet is based on classic design with modern features. The GF1 is both lightweight and durable due to a fiberglass composite shell. The driver will notice a lighter feel and less neck strain when wearing the GF1 helmet. The G-79 interior impact liner is produced using the proprietary, Conehead Technology.

GF1GFO3121.....\$179.99



Revo

- Rating: SNELL SA2015
- Removable Cheek Pads
- Siphon12 Ventilation
- Network Reinforced mounting points for Helmet Devices.
- Sizes: XS- XXL
- Colors, BK, WH, MB

G-Force Racing Gear has created the all new REVO Full Face helmet to provide a premium fit and style option to the helmet line. The new REVO is built with a Strategically Reinforced Composite Shell engineered specifically for the SNELL SA2015 specs. This SRC Shell is coated with a deep gloss white, gloss black or matte black paint. Across the chinbar and crown of the helmet, you will see the polished aluminum grill guards of the Siphon12 Ventilation Network, a system of 6 intake ports, 2 forehead ports and 4, rearward exhaust ports designed to move heated out of the helmet. The bottom of the REVO Helmet is more contoured to today's helmet restraint devices and is lined with

RevoGFO3410.....\$299.99



Revo Carbon

G-FORCE Racing Gear has created the all new REVO CARBON Full Face helmet to provide a premium fit and style option to the helmet line with a carbon finish. The new REVO CARBON is built with a reinforced Carbon Composite Shell engineered specifically for the Snell SA15 specs. This Carbon Composite Shell is coated with a deep gloss clear for a brilliant shine. Across the chinbar and crown of the helmet, you will see the polished aluminum grill guards of the Siphon12 Vent Network, a system of 6 intake ports, 2 forehead ports and 4, rearward exhaust ports designed to move heated out of the helmet. The bottom of the Helmet is more contoured to today's helmet restraint devices and is lined with a rubber gasket made for easy use and cleaning.

Revo Carbon.....GFO3411BK.....\$474.99



Pivot Kits

SA 2015: GF3
Pivot KitsGFO3016.....\$14.99



Hex Key

Hex Key.....GFO8620.....\$7.99



Adult Helmet Shields

- EX9 (Clear).....GFO8631.....\$44.99
- EX9 (Dark Smoke).....GFO8632.....\$44.99
- EX9 (Mirror Light Smoke).....GFO8633.....\$44.99
- EX9 (Amber).....GFO8634.....\$44.99
- EX9 (Blue).....GFO8635.....\$49.99
- EX9 (Light Smoke).....GFO8636.....\$44.99
- Profit for GF3 (Clear).....GFO8601.....\$34.99
- Profit for GF3 (Smoke).....GFO8602.....\$34.99
- Profit for GF3 (Mirror Smoke).....GFO8603.....\$34.99
- Profit for GF3 (Amber).....GFO8604.....\$39.99
- Profit for GF3 (Blue Mirror).....GFO8605.....\$39.99
- Profit for GF3 (Light Smoke).....GFO8606.....\$34.99
- Revo (Clear).....GFO8701.....\$54.99
- Revo (Smoke).....GFO8702.....\$64.99
- Revo (Mirror Smoke).....GFO8703.....\$64.99
- Revo (Amber).....GFO8704.....\$64.99
- Revo (Blue Mirror).....GFO8705.....\$64.99

Junior Helmet Shields

Profit Jr. (Clear).....GFO8611.....\$34.99



Helmet Sizing Chart

Size	Hat	Inches
X-Small	6-5/8" to 6-3/4"	20-7/8" to 21-1/4"
Small	6-7/8" to 7"	21-5/8" to 22"
Medium	7-1/8" to 7-1/4"	22-3/8" to 22-3/4"
Large	7"-3/8" to 7-1/2"	23-1/8" to 23-1/2"
X-Large	7-5/8" to 7-3/4"	23-7/8" to 24-1/4"
XX-Large	7-7/8" to 8"	24-3/4" to 25-1/8"





2 Layer Suit GF745

- SFI 3.2A/5 Rating • TPP rating of 23
- LW Nomex/Nomex knit • Size S-XXL
- Color: Black, Blue, or Red

It has been designed to provide a premium product at reasonable prices. This multi-layered, meta-aramid/para-aramid blend suit with a fire retardant knit inner exceeds SFI 3.2a/5 standards in all categories

- Suit.....GFO4745...**\$399.99**
- JacketGFO4746...**\$229.99**
- Pants.....GFO4747...**\$209.99**
- Boot Cuffed Pants

Nomex Fabric
3.2A/5 Rating

Brand New!

3 Layer Suit GF505

- SFI 3.2A/5 Rating • Pyrovatex Fabric
- TPP rating of 26 • Size S-XXXL
- Color: Black, Red, and Blue.

The GF505 is our most popular suit available in an SFI-5 rating. We ask any driver to compare the 505 suit to our competitors. We go above and beyond what you have come to expect from an entry-level multi-layer suit. This suit comes with std epaulets, belt with loops, matching Nomex cuffs, arm and leg stripes, and a large chest white-board with contrasting piping. All with white stripes across the chest & down the arms & legs.

- Suit.....GFO4380...**\$269.99**
- JacketGFO4385...**\$164.99**
- Pants.....GFO4386...**\$144.99**

Pyrovatex Fabric
3.2A/5 Rating

Adult Only

2 Layer Suit GF525

- SFI 3.2A/5 Rating • Pyrovatex Fabric
- TPP rating of 21 • Black, Red, and Blue.
- Size S-3XL (4XL Pants & Jackets)

It has a SFI 3.2A/5 rating. The SFI 3.2A/5 tag is included and has been moved to the left arm cuff so that tech inspectors can easily see the certification. The multi layers of this suit have been produced with a proprietary blend of Pyrovatex fabric & classified materials to achieve the TPP rating of 21. The inner layer of the GF-525 is a comfortable bend that wicks moisture from the skin while providing a breathable feel. Has Boot Cuff.

- Suit.....GFO4525...**\$264.99**
- JacketGFO4526...**\$164.99**
- Pants.....GFO4527...**\$144.99**

Pyrovatex Fabric
3.2A/5 Rating

1 Layer Suit GF145

- SFI 3.2A/1 Rating • Pyrovatex Fabric
- TPP rating of 10 • Black, Red, and Blue.
- Adult Size: S-3XL
- Child Size: S-L

The GText construction that has been used in all G-Force Racing Gear suits has been utilized to manufacture the GF-145 at specs that exceed the SFI 3.2A/1 specifications. The SFI 3.2A/1 tag is included and has been moved to the left arm cuff so that tech inspectors can easily see the certification. The single layer of this suit is made with Pyrovatex fabric to achieve the TPP rating of near 10. Boot Cuff on all.

- Suit.....GFO4145...**\$109.99**

Pyrovatex Fabric
3.2A/1 Rating

Adult & Child

1 Layer Suit GF125

- SFI 3.2A/1 Rating • Pyrovatex Fabric
- TPP rating of 10 • Black, Red, and Blue.
- Size S-3XL (4XL Pants & Jackets)

The GText construction that has been used in all G-Force Racing Gear suits has been utilized to manufacture the GF-125 at specs that exceed the SFI 3.2A/1 specifications. The SFI 3.2A/1 tag is included and has been moved to the left arm cuff so that tech inspectors can easily see the certification. The single layer of this suit is made with Pyrovatex fabric to achieve the TPP rating of near 10. Boot Cuff on all.

- Suit.....GFO4125...**\$109.99**
- Jacket.....GFO4126...**\$69.99**
- Pants.....GFO4127...**\$59.99**

Pyrovatex Fabric
3.2A/1 Rating



Sizing Chart for Driving Suit

SIZE	CHEST	STOMACH*	WAIST**	HIP	INSEAM	SLEEVE***	NECK
CHILD (S)	27-29"	23-26"	21-24"	26-28"	18-19"	20-21"	10.5-11.5"
CHILD (M)	30-32"	27-29"	24-26"	30-32"	21.5-22.5"	23-24"	11.5-12.5"
CHILD (L)	33-34"	29.5-31"	26-28"	33.5-34.5"	24"	26.5-27.5"	12-13"
S	36-38"	32.5-35"	29-32"	35-37"	29-30"	28-29"	13-14"
M	38-41"	35-38"	32-35"	38-40"	30-31"	30-32"	13.5-15"
L	42-46"	40-43"	38-40"	42-44.5"	32-33"	33-34"	15-16.5"
XL	46-49"	43-46"	41-43"	45-48"	32.5-33.5"	34-35"	16-17.5"
XXL	50-54"	47-51"	44-48"	50-52.5"	32.5-33.5"	35-37"	17.5-19"
XXXL	70.5"	66"	70"			41.5"	24-25"

* Measure at the largest circumference ** Measure at your normal beltline
*** Measure from the back of the neck at the ctr to your wrist; arm bent 90° angle at the elbow

G5 Gloves Adult & Child

They are designed for those who require the stringent SFI-5 requirements while giving the racer the lightweight feel and flexibility of the G1 RaceGrip glove. Premium quality Nomex and premium leather are used along with a reinforced leather palm, leather reinforced knuckle pad, and adjustable Velcro wrist closure. The G5 gloves are lined with a flame retardant fabric that wicks moisture away from your hands while maintaining that unique RaceGrip feel. SFI 3.3/5 RATING. Color: Black, Blue, Red, & Orange. Size: XXS-XXL & Child S-M.

- GFO4101...**\$39.99**



G6 Gloves Adult

They were designed to be the new standard in functionality in an affordable glove. This SFI 3.3/5 rated, a flame retardant outer knit layer, supple leather palm and a Velcro adjuster to snug the fit. This allows for less weight and bulk on the hands that all users will appreciate. It uses Cross-Hatch stitching for durability. With a mid-level price point the G6 is set to be the first choice for an SFI 3.3/5 Glove. Colors Black, Blue, or Red. Size S-XXL.

- GFO4106...**\$59.99**



G7 Silicone Infused Glove SFI 3.3/5

The all new G7 Race Glove was designed to offer the first Silicone Infused glove at a minimal price. This SFI 3.3/5 rated, professional driver's glove is made with a flame retardant base knit layer, Silicone Infused palm and a simple elastic wrist to snug the fit. This allows for less weight and bulk on the hands that all users will appreciate. G-Force Racing Gear uses CrossHatch stitching for durability. Sold in black with gray colors and all come with the black and red silicone for grip. With a mid-level price point the G7 is set to be the first choice for a high grip glove. Sold in Black and Gray design with Red accents. Size: S-XXL.

- GFO4107...**\$69.99**



GF 235 RaceGrip Mid Top Shoes

Full leather construction with double-stitch seams. Rubberized sole for long life and good pedal feel. Ankle padding for comfort and fit. Comfort fit insoles for superior arch support. The shoe is lined with fire-retardant cotton to keep your feet cool in hot racing conditions and extra comfort is provided by a RaceGrip innersole with arch support. The RaceGrip sole is manufactured from a high grip rubber compound and its low-profile beveled sole that keeps the shoe from catching on the pedals. SFI 3.3/5 RATING. Color: Black, Blue, and Red. • Size: 3-14.

- GFO0235...**\$69.99**



GF 236 Shoe *While Supplies Last*

The tread rolls up the back and has chamfered edging to prevent any catches in a heated pedal exchange. The laces on the Pro Series Racing Shoe are secured under a Velcro enclosure to stop annoying slack from coming loose. The back of this shoe has a deep cut-out where the shoe meets the back of the leg to allow for the rolling and rocking that comes with perf driving. SFI 3.3A/5 Rating. Size: 3-14. Color: Black.

- GFO0236...**\$89.99**



Boot Heel Shield

They are constructed from exclusive Coolquilt and FR cotton to provide a cooler racing environment for any racing shoe. They also offer added protection against engine and exhaust heat.

- GFO1001...**\$24.99**



2 Piece Drag Suit GF 575 Nomex Fabric 3.2A/15 Rating

- SFI 3.2A/15 Rating • TPP rating of 63
- Multiple Layers using both Nomex and Kevlar layer
- Size S-XXL
- Color: Only Black

- JacketGFO4576...**\$749.99**
- Pants.....GFO4577...**\$699.99**



Latch & Link Seat Belts



Individual Shoulder

• SFI 16.1 RATING • Colors: Black, (Blue and Red Prices are higher.)
Adjustment Length • Shoulder: 26" - 50" • Pull-Up Lap: 38" - 80"
 • Pull-Down Lap: 38" - 67" • Sub-Strap: 7" - 25"

5 point Harness Black.....Pull-Down..GFO6000BK.....\$69.99
 5 point Harness Red/Blue..Pull-Down..GFO6000RD/BU \$74.99
 6 point Harness.....Pull-Down..GFO6001.....\$74.99
 5 point Harness.....Pull-Up.....GFO6100.....\$89.99



H-Type Pull Down

• SFI 16.1 RATING • Colors: Black, Blue, and Red.
Adjustment Length • Shoulder: 26" - 80" • Pull-Down Lap: 38" - 67"
 • Sub-Strap: 7" - 25"
 5 point HarnessPull-DownGFO6030.....\$84.99



V-Type Pull Down

• SFI 16.1 RATING • Black, (Blue & Red prices are higher). • Sub-Strap: 7" - 25"
Adjustment Length • Shoulder: 26" - 80" • Pull-Down Lap: 38" - 67"
 • Sub-Strap: 7" - 25"
 5 point Harness Black.....Pull-Down...GFO6020BK.....\$69.99
 5 point Harness Red/Blue..Pull-Down...GFO6020RD/BU...\$74.99



Nascar Style

• SFI 16.5 RATING • Colors: Black, Blue, and Red.
 Nascar legal harness set with single adjustment lap belt (similar to Sprint cars) and anti-slip springs in all adjusters.
 5 point HarnessPull-Up.....GFO6240.....\$109.99
 6 point HarnessPull-Up.....GFO6241.....\$119.99

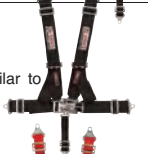

Junior Racer

• SFI 16.1 RATING • Colors: Black, Blue, and Red.
Adjustment Length • Shoulder: 19" - 35" • Pull-Down Lap: 18.5" - 49" • Sub-Strap: 6" - 15.5"
 5 point HarnessPull-Up.....GFO6460.....\$69.99



Camlock Seat Belts

Individual Shoulder

• SFI 16.1 RATING • Colors: Black, Blue, and Red.
Adjustment Length • Shoulder: 26" - 50" • Pull-Up Lap: 38" - 80"
 • Pull-Down Lap: 38" - 67" • Sub-Strap: 7" - 25"

5 point Harness Black.....Pull-Down...GFO7000BK.....\$149.99
 5 point Harness Red/Blue..Pull-Down...GFO7000RD/BU \$154.99
 6 point Harness.....Pull-Down...GFO7001.....\$154.99
 5 point Harness Black.....Pull-Up.....GFO7100BK.....\$154.99
 6 point Harness.....Pull-Up.....GFO7101.....\$154.99



Camlock H-Type Harness Set

• SFI 16.1 RATING • Colors: Black, Blue, and Red.
Adjustment Length • Shoulder: 26" - 80" • Pull-Up Lap: 38" - 67"
 • Pull-Down Lap: 38" - 80" • Sub-Strap: 7" - 25"

5 point Set Black...Pull-DownGFO7030BK \$164.99
 5 point Set.....Pull-Up.....GFO7130.....\$159.99



Camlock U-Type Shoulder Drag Racing Harness Set

• SFI 16.1 RATING • Colors: Black, Blue, and Red.
Adjustment Length • Shoulder: 22" - 36" • Pull-Up Lap: 22" - 60"
 • Sub-Strap: 7" - 25"

4 point SetPull-UpGFO7543.....\$179.99



Junior Racer

Camlock Harness Set

• SFI 16.1 RATING • Colors: Black, Blue, and Red.
Adjustment Length • Shoulder: 19" - 35" • Pull-Up Lap: 18.5" - 49"
 • Sub-Strap: 6" - 15.5"

5 point SetPull-UpGFO7460.....\$149.99



Pro-Series 2" Latch Link 5-Point Individual Harness

Pro-Series 2" Latch Link 5-Point Individual Harness
 2" Webbing
 Pull-Down Lap Adjusters

5 point HarnessPull-DownGFO6570...\$69.99



Pro-Series 2" Camlock 5-Point Individual Harness

Pro-Series 2" Latch Link 5-Point Individual Harness
 2" Webbing
 Pull-Down Lap Adjusters

5 point HarnessPull-DownGFO7570...\$149.99



4 Point Pull Down Seat Belts

2 inch sewn shoulder/lap harness. Sewn shoulder padding. E-Z alum. shoulder adjusters. Midnight Black hardware (including leather piece behind the latch). Removable sternum strap. MOLLE attachment system on shoulder straps
 Pull-DownGFO9100.....\$109.99



5 Point Pull Down Seat Belts

2 inch sewn shoulder/lap harness. Sewn shoulder padding. E-Z alum. shoulder adjusters. Midnight Black hardware (including leather piece behind the latch). Removable sternum strap. MOLLE attachment system on shoulder straps.
 Pull-DownGFO9101.....\$119.99



5 Point Pull Down SFI 16.1 Seat Belts

3 inch SFI 16.1 Rated harness. Sewn shoulder padding. E-Z alum shoulder adjusters. Midnight Black hardware (including leather piece behind the latch).
 Pull-DownGFO9002.....\$99.99



6 Point Camlock

16.5 Rated Pull Down Seat Belts

Restraint device ready shoulder belts featuring 3" to 2" webbing. Midnight Black hardware. Speed Pull Tabs for quick tension release. Quarter Turn camlock buckle for easy engagement and quick release. Lap adjusters contain Anti-Slip Springs for added security. LW E-Z alum shoulder adjusters.
 Pull-DownGFO7601.....\$199.99



6 Point Camlock

FIA/SFI 16.5 Rated Pull Up Seat Belts

Pull-Up lap adjustment with Anti-Slip Springs. Restraint device ready shoulder belts featuring 3" to 2" webbing. Midnight Black Hardware. Speed Pull Tabs for quick tension release. Quarter Turn camlock buckle for easy engagement and quick release. Comes std with Snap Hook hardware. E-Z alum shoulder adjusters.
 Pull-Up.....GFO7611.....\$249.99

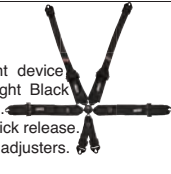

Nomex Underwear

Flame-retardant underwear is essential for providing the last line of defense in a fire. The soft knit is hypoallergenic and more comfortable on the skin than the old standby. The double stitching provides added durability.
 • SFI 3.3 RATING • Size: S-XXL

Top.....GFO4160...\$69.99
 Bottom.....GFO4161...\$69.99



Socks

They softest and most comfortable on the market today. Made from soft knit Nomex material, our socks give the driver or crew member hypoallergenic coverage with a soft texture feel. Sometimes a drivers shoe is just not enough and socks provide an extra layer of protection. Size: S-XL

GFO4140...\$19.99



Head Socks

Made from an innovative soft knit CoolTec material, our balaclava gives the driver or crew member hypoallergenic coverage with a soft texture feel and a minimum TPP rating of 10. Single layer balaclava comes with 1 large eyeport. The double layered balaclavas are available in single or dual eye port versions. SFI 3.3 RATING • Color: Black, Blue, Red, and Natural.

GFO4112

1 Lyr EyePort..\$34.99 • 2 Lyr EyePort..\$59.99



Helmet Skirt

Use the G-Force Racing Gear Nomex helmet skirt with our SideDraft helmet and any fresh air system for the ultimate in driver comfort. Color: Black, Red, Blue, and Natural.

GFO4240...\$44.99

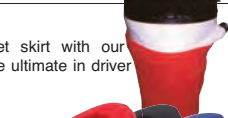

SFI 3.3 Rated Neck Supports

It is constructed of high density, fire retardant foam. The outer layer covering is soft, knit CoolTec and is removable for easy cleaning. • SFI 3.3 Rating • Color: Black, Blue, or Red.

Medium (12.5"-15.5").....GFO4122MED(color)...\$34.99

Large (15.5"-19.5").....GFO4122LRG(color)...\$34.99



Arm Restraints SFI 3.3 Rating

The arm restraints are covered in flame-retardant foam and flame retardant cloth - not cheaper nylon covered arm restraints used by other manufacturers. The cuffs and straps are made from high-strength nylon. For ease of use, we use individual straps with quick release clips.

• Color: Black, Blue, or Red.

• Sizes: Adult and Junior.

GFO4087...\$29.99



Harness Pads

They are covered in a flame-retardant fabric with a Velcro closure for easy adjustment or removal.
 • Colors: Black, Blue, and Red.

3" Standard.....GFO4098...\$19.99

2" Tuner/Jr Belt.....GFO4097...\$19.99



BAGS

Helmet Bag



Protect your helmet in Simpson's plush helmet bag with iconic SIM harness patches. Race inspired checkered graphics and logo accent zippers complete the look. Sturdy 600d poly construction. SIM23305\$34.95



Raceway Helmet Bag

Designed for your Helmet, Head & Neck Device and Extra Shields. Carry on compatible. Sturdy 600d poly construction. Padded, lined and vented main compartment. Side accessory compartment and ID Window. Padded grab handle and removable shoulder strap. Heavy duty hardware. Rugged protective bottom with skids. Iconic Simpson harness patches. Simpson red accent zippers. Race inspired checkered graphics. Dimensions: 20" L x 11" W x 13" H SIM23304\$54.95



Speedway Bag

It can hold your helmet, a head and neck restraint, suit, shoes, gloves and more. Padded, lined and ventilated main compartment. Interior mesh organizer compartment. Wet/Dry side compartments. ID window, padded grab handles and removable shoulder straps. Race inspired checker graphics, iconic Simpson harness patch and logo accent zippers complete the look. Dimensions 27" L x 13" W x 15" H SIM23301\$89.95



Super Speedway Bag

Comfortably holds helmet, Head and Neck device, 2 suits, 2 shoes, 2 gloves and everything else you need for a day at the track. Heavy duty trolley system and smooth rolling polyurethane wheels. Large padded and lined main compartment, separate top compartment. Separate helmet storage compartment. Exterior pockets and compressions straps. ID Window and multiple grab handles. Heavy duty hardware. Race inspired checker graphics, iconic Simpson harness patch and logo accent zippers complete the look. Dimensions 33.5" L x 18" W x 16.5" D SIM23303\$199.95

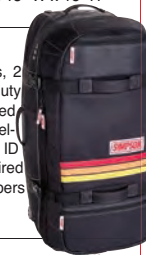

Pit Pack

It has plenty of Simpson style is designed to hold every-thing you need to keep you organized for a day at the track. Dual main compartments. A laptop pocket with external access. Mesh drink holder. Multiple accessory pockets and an organizer front pocket. Padded back panel and shoulder straps. Size: 18" L x 13" W x 10" D. SIM23307\$59.95



Racing Suit Tote Bag

This bag is the perfect size for carrying your racing suit to the track. The tote bag features sturdy 600d poly construction, logo accent zippers and iconic Simpson harness patches. SIM23306\$19.95



Dual Shield Bag

It is designed to hold 2 shields with separation between. It can be machined washed. Microfiber is excellent for cleaning them. SIM23900.....\$5.99



Padded Helmet Bag



A double-lined tear resistant nylon outer-shell and soft faux shearing liner keeps your gear safe while two easy-to-carry handles make transporting your helmet to and from the track a breeze. The Impact helmet bag offers a full length zipper and extra space for easy helmet storage and integrated pockets provide for miscellaneous accessories. IMP71000915.....\$52.00



Super Race Bag

It offers 3 separate compartments and is designed to hold your helmet, suit, head and neck restraint, gloves, shoes and accessories. Constructed of heavy-duty nylon with webbed handle and a removable shoulder strap, the Gear Bag has one large main compartment and two 3/4 zip side pockets and reinforced base to help the bag keep its shape during loading & carrying. 27" long x 12" wide x 11" deep. IMP72000010.....\$49.00



Angle Front Net



Similar to the standard G-Force Racing Gear Ribbon Window Nets with the addition of webbing to match the angle of the A-pillar of the race car. Measures: 18" x 26". Colors: Black, Blue, Red, White, Yellow, Orange, Purple, Green, and Silver. GFO4134...\$24.99

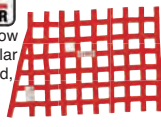

Ribbon Window Net

G-Force Racing Gear Ribbon Window Nets are all jig built to ensure consistent dimensions. 1" wide webbing and double overlap construction provide a strong, durable net. Measures: 18" x 23". Colors: Black, Blue, Red, White, Yellow, Orange, Purple, Green, and Silver. GFO4131...\$19.99

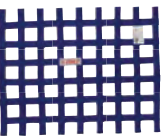

Sprint Car/Quarter Midget Window Net

Our exclusive 5-point mounting system allows the driver to accurately locate the position of the cage net and limit the vertical movement. Colors: Black, Blue, Red, White, Yellow, Orange, Purple, Green, and Silver. GFO4130...\$14.99



SFI Rated Mesh Window Net

• Measures: 17" x 21.5" • Color: Black GFO4135BK...\$24.99



Gear Bag



Super bag with built-in wet storage is perfect for boots or dirty clothes. Expandable side pocket for gloves and two front pockets for tear offs, log books, rule books, and more. 24" L x 12" W x 14" H....GFO1005...\$39.99



GF Helmet Bag

It is an improvement on a tested design. It has taken the standard fleece lined bag and upsized it for more space. Store your helmet with a head and neck device in this bag for safe keeping. GFO1006...\$19.99



GF Backpack

It is perfect for the local track visit or a multi-state journey. Designed by former crew members and drivers, this pack fits the need of most any application. 8 separate compartments are standard in this pack, 1 long side pocket, 2 short side pockets, 1 laptop backside sleeve, 1 hand held device pocket, 1 bottom edge pocket, 1 shallow front pocket and 1 main deep pocket are std. Adjustable shoulder straps and even a port for your headphones make this the bag to travel with. GFO1007...\$49.99



Roll Bar Padding Soft

- Fire retardant • 3' length
- Offset hole provides more protection
- Black.....KIR99001\$5.01
- Red.....KIR99002\$5.01
- Blue.....KIR99003\$5.01
- Yellow.....KIR99004\$5.01
- Orange.....KIR99005\$5.01
- Purple.....KIR99006\$5.01
- Gray.....KIR99007\$5.01

SFI 45.1 Hi-Density Roll Bar Padding



3' lengths. Fire retardant high density foam. U-shaped design velcros on. Black.

- 1/2" thick ...JAZ690-003-01 \$30.52
- 3/4" thick ...JAZ690-002-01 \$30.95
- 1" thick ...JAZ690-001-01 \$39.28

SFI Roll Bar Padding

It is ideal for tight areas and has a unique, compact design that provides driver protection to a specific area. Each size has peel and stick backing for easy installation, meets SFI 45.1 specs and is sold in 3' long sections (black only). 5/8" Thick SFI Mini Roll Bar Padding, Fits 1-1/4" To 1-3/4" O.D. Tubing. ALL14112.....\$24.99

Hi-Density Roll Bar Padding

Fire retardant high density foam. 1" Thick padding. U-shaped design. Self adhesive. 3' lengths

- 7/8" to 1-3/8" tubing
- SFI 45.1Black ...KIR99021\$24.58
- SFI 45.1Red.....KIR99022\$19.97
- SFI 45.1Blue.....KIR99023\$19.97

- 1-1/2" to 1-7/8" tubing
- SFI 45.1Black ...KIR99011.....\$24.58
- SFI 45.1Red.....KIR99012.....\$24.58
- SFI 45.1Blue.....KIR99013.....\$24.58
- Blue.....KIR99033.....\$13.05

Tie Wraps

3/16" tie wraps, 50 per pack. (BK) Black, (DB) Dk. Blue, (G) Green, (GR) Gray, (O) Orange, (P) Purple, (R) Red, (Y) Yellow, (W) White. TIE 12 (.....\$4.75

Champ Suit 2 Layer



It was manufactured utilizing advanced Nomex materials providing drivers with the highest level of fire protection, breathability, comfort and professional modern appearance. The 360-degree, full floating sleeves, as well as both crotch and lower back stretch panels provide full range of motion while driving. The Champ suit is lightweight and a perfect choice for auto racing venues and exceeds the stringent SFI 3.2A/5 & FIA 8856-2000 homologation stds.

Black/Red**Black/Blue****White/Red****White/Blue**
 S.....K1-20-CHA-NR-S.....K1-20-CHA-NB-S.....K1-20-CHA-WR-S.....K1-20-CHA-WR-S
 M.....K1-20-CHA-NR-M.....K1-20-CHA-NB-M.....K1-20-CHA-WR-M.....K1-20-CHA-WR-M
 L.....K1-20-CHA-NR-L.....K1-20-CHA-NB-L.....K1-20-CHA-WR-L.....K1-20-CHA-WR-L
 XL.....K1-20-CHA-NR-XL.....K1-20-CHA-NB-XL.....K1-20-CHA-WR-XL.....K1-20-CHA-WR-XL
 2XL.....K1-20-CHA-NR-2XL.....K1-20-CHA-NB-2XL.....K1-20-CHA-WR-2XL.....K1-20-CHA-WR-2XL
 3XL.....K1-20-CHA-NR-3XL.....K1-20-CHA-NB-3XL.....K1-20-CHA-WR-3XL.....K1-20-CHA-WR-3XL
\$895.00**\$895.00****\$895.00****\$895.00**

GT 2 Layer Suit

The K1 GT auto racing suit is a Nomex®, SFI-rated fire suit that is perfect for auto racing venues. The GT suit has a TPP rating of 25.5 - a full 6 points higher than what is required by SFI! It's 2-layer design is both light weight and breathable.



Black/Teal**Black/Green****Black/Orange**
 S.....K1-20-GT2-NB-S.....K1-20-GT2-NV-S.....K1-20-GT2-NO-S.....**\$595.00**
 M.....K1-20-GT2-NB-M.....K1-20-GT2-NV-M.....K1-20-GT2-NO-M.....**\$595.00**
 L.....K1-20-GT2-NB-L.....K1-20-GT2-NV-L.....K1-20-GT2-NO-L.....**\$595.00**
 XL.....K1-20-GT2-NB-XL.....K1-20-GT2-NV-XL.....K1-20-GT2-NO-XL.....**\$595.00**
 2XL.....K1-20-GT2-NB-2XL.....K1-20-GT2-NV-2XL.....K1-20-GT2-NO-2XL.....**\$595.00**
 3XL.....K1-20-GT2-NB-3XL.....K1-20-GT2-NV-3XL.....K1-20-GT2-NO-3XL.....**\$595.00**

Precision 2 Layer Suit

Combining precision styling, fit and revolutionary design we have created a suit that not only offers almost zero restrictions to movement, but raises the competitive bar with its ultra-lightweight outer shell, and unbeatable breathability at a fraction of the cost. This advanced, premium Nomex driver's suit is precisely the choice for racers across multiple segments of the motorsports industry.



Black/Blue**Black/Red****Black/Orange**
 S.....K1-20-PR2-NB-S.....K1-20-PR2-NR-S.....K1-20-PR2-GO-S.....**\$699.00**
 M.....K1-20-PR2-NB-M.....K1-20-PR2-NR-M.....K1-20-PR2-GO-M.....**\$699.00**
 L.....K1-20-PR2-NB-L.....K1-20-PR2-NR-L.....K1-20-PR2-GO-L.....**\$699.00**
 XL.....K1-20-PR2-NB-XL.....K1-20-PR2-NR-XL.....K1-20-PR2-GO-XL.....**\$699.00**
 2XL.....K1-20-PR2-NB-2XL.....K1-20-PR2-NR-2XL.....K1-20-PR2-GO-2XL.....**\$699.00**
 3XL.....K1-20-PR2-NB-3XL.....K1-20-PR2-NR-3XL.....K1-20-PR2-GO-3XL.....**\$699.00**

Victory 1 Layer Suit

It has designed an industry first breathable suit. The Victory SFI 3.2A/1 Single Layer suit is constructed of Proban fire retardant cotton material with Hydro Oleo treatment to repel fluids. This unique material has been designed to allow air to pass through to keep cool, yet maintain full fire protection for the driver. This suit includes full 360 degree arm gussets to provide optimal mobility and the Crotch Stretch Panel allows the driver to easily slip in and out of the vehicle without the worry of pulled seams.



S.....K1-20-VIC-N-S.....**\$215.00**
 M.....K1-20-VIC-N-M.....**\$215.00**
 L.....K1-20-VIC-N-L.....**\$215.00**
 XL.....K1-20-VIC-N-XL.....**\$215.00**
 2XL.....K1-20-VIC-N-2XL.....**\$215.00**
 3XL.....K1-20-VIC-N-3XL.....**\$215.00**



Triumph 2 - 1 Layer Suit

Meeting stringent SFI 3.2A/1 certification standards, our K1 single layer race suit is an ideal fire suit for a variety of racing classes, including dirt track and oval racing leagues such as Midgets, Quarter Midgets, Bandoleros, Sprint Cars, Legends, and Thunder Roadsters as well as sports car racing classes such as SCCA Solo and ProSolo.



Suit.....**Jacket**.....**Pants**
 S.....K1-20-TR2-NW-S.....K1-21-TR2-NW-S.....K1-22-TR2-NW-S
 M.....K1-20-TR2-NW-M.....K1-21-TR2-NW-M.....K1-22-TR2-NW-M
 L.....K1-20-TR2-NW-L.....K1-21-TR2-NW-L.....K1-22-TR2-NW-L
 XL.....K1-20-TR2-NW-XL.....K1-21-TR2-NW-XL.....K1-22-TR2-NW-XL
 2XL.....K1-20-TR2-NW-2XL.....K1-21-TR2-NW-2XL.....K1-22-TR2-NW-2XL
 3XL.....K1-20-TR2-NW-3XL.....K1-21-TR2-NW-3XL.....K1-22-TR2-NW-3XL
\$99.00.....**\$99.00**.....**\$99.00**

K1 Champ Shoe SFI 3.3/5 Certified

Our K1 Champ Nomex race shoes are specifically designed to meet the needs of auto racers, and are SFI 3.3/5 certified to meet competition eligibility. Constructed from high quality Nomex, leather and rubber, the Champ is a useful and comfortable racing shoe that not only provides superb pedal feel, but also protection against fire. **Sizes: 6.5-14**
 Black/White.....K1-24-CHP-NG-(size)..**\$155.00**



Champ LW 2-Lyr Nomex Gloves SFI 3.3/5 & FIA 8856

It was developed in conjunction with professional race car drivers in all classes to provide a top of the line, FIA 8856-2000 & SFI 3.3/5 rated Nomex glove, with the latest in innovative features, while remaining the most affordable in class. This ultra-lightweight glove, with anatomically correct shape, provide maximum comfort and functionality. **Colors: Black (N), Blue (B), Red (R), Flo Blue (FB), Flo Red (FR), Flo Green (FV), or Flo Yellow (FY). Sizes: S-XL.**
 K1-23-CHP-(color)-(size)**\$95.99**



Flex Gloves

SFI 3.3/5 - FIA 8856-2000

Complying with both FIA 8856-2000 & SFI 3.3/5 homologation stds. Featuring a seamless, pre-curved palm and finger design that naturally flows with the contour of the hand, the palm of the Flex glove is strategically engineered with an ultra-grip, fire resistant silicon surface for improved flexibility, grip and comfort. **Colors: Black (NG), Red (RG), White (GW), Flo Blue (FB), Flo Green (FV), and Flo Yellow (FY). Sizes: S-XL.**
 K1-23-FLX-(Color)-(Size)**\$115.99**



Track 1 SFI 3.3/5

Certified to SFI 3.3/5 standards, the NEW Track 1 Nomex gloves incorporate the latest, innovative materials and premium design features at an entry level cost. Pre-curved fingers and palm help reduce fatigue while driving. New strategically positioned silicone printing throughout glove for weight savings & improved grip. Pre-Curved fingers w/ external stitching. Elastic cuff opening for ease and secure fit. Minimal externally stitched seams to eliminate discomfort and pressure points while driving. **Colors: Black (N), Blue (B), or Red (R). Sizes S-XL.**
 K1-23-TR1-(Color)-(Size)**\$79.00**



K1 Premier Double Layer Nomex Headsock

Our double-layer, fire-resistant Nomex head sock is ideal for both karters and auto racers. Not only does it provide enhanced fire protection and safety, but it has been designed for comfort and usability as well. Perhaps most importantly, though, it is designed and manufactured in compliance with FIA standards, making it competition eligible. It is designed to meet the highest quality standards at an affordable price, as we understand the importance of budgets when it comes to racing.
 White.....K1-26-DLH-W**\$45.00**



K1 Premier Nomex Tech Layers

SFI 3.3 Approved SFI requires a TPP (Thermal Protective Perf) rating of 6. It is tested at 11.9 - Almost double the minimum requirement! Our new Premier shirt is made with a softer material and a more ergonomic, form-fit cut to prevent bunching and provide better comfort. **Sizes: 6XS-3XL.**
 Tops - White.....K1-26-PUS-W-(size)**\$99.95**
 Bottoms - White...K1-26-PUP-W-(size)**\$87.00**

K1 Premier - Nomex Fire Socks

Nomex fabric, which both absorbs and wicks moisture away from the body and provides invaluable protection against heat and fire, provides the racer with everything that he or she could want in a fabric. It is lightweight and comfortable, yet durable enough to withstand extreme temperatures.
 White.....K1-26-NSO**\$22.00**

K1 Single Layer Nomex Headsock

Our single-layer, fire-resistant Nomex® balaclava is a great head sock for both karters and auto racers. Constructed from single-layer Nomex for enhanced breathability and comfort, and featuring a reverse stitched design for a closer and less obtrusive fit, our fire-resistant balaclava head sock is a great addition for individuals who regularly compete while wearing a helmet. Not only can it provide additional comfort, but it will make you safer in the unfortunate event that an accident results in a fire. Put simply, if you race karts or are involved in auto racing, we highly recommend our Nomex balaclava head sock.
 White.....K1-26-SLH-W**\$39.00**
 Black.....K1-26-SLH-N**\$39.00**



K1 Safety-X Single Layer

SFI 3.3 Approved SFI requires a TPP (Thermal Protective Performance) rating of 6. It is tested at 11.9 - Almost double the minimum requirement! Our new Safety X shirt is made with a softer material and a more ergonomic, form-fit cut to prevent bunching and provide better comfort. **Sizes: S-3XL.**
 Top Black/Blue.....K1-26-XUS-N.....**\$130.00**
 Bottom Black/Blue.....K1-26-XUP-N.....**\$115.00**



DIRT MODIFIED & MIDGETS

79 Series 10° Layback Containment Seat



Designed for:
Sprint Cars,
DIRT Modifieds

10 degree layback. - Constructed from TIG welded .080" 5052 grade aluminum. Additional MIG welding adds strength. - Contoured elongated bottom for added thigh and hip support. - Right side leg extension built in, left side cut back for easy entry, exit. - Designed to accommodate all head and neck restraints. - Unique design allows up to 2" of energy absorbing padding on bottom. - Cover comes fully padded with 1/2" energy absorbing padding. - Rib and reinforced Shoulder supports have extra 1/2" energy absorbing padding directly on seat.

Seat & Cover

14"KIR79140KIT **\$1295.00**
14.5".....KIR79145KIT **\$1295.00**
15"KIR79150KIT **\$1295.00**
15.5".....KIR79155KIT **\$1295.00**
16"KIR79160KIT **\$1295.00**
17"KIR79170KIT **\$1295.00**

89 Series Intermediate 10° NE Modified, Sprint Car Seat



Smaller sizes fit Midgets & 600 Micros. Easily removable cover has additional 1/2" energy absorbing padding for extra lumbar support. 10° layback. Will fit all early style Sprint Chassis. Designed to accommodate all head & neck restraints. Constructed from TIG welded .100" 5052 grade alum. MIG welding adds strength. Contoured elongated bottom reinforced for added thigh & hip support. Energy absorbing padding on seat bottom. Rib & reinforced shoulder supports have extra 1/2" energy absorbing padding directly on seat. Right side leg extension built in, left side cut back for easy entry, exit.

Seat & Cloth Cover Combo

14".....KIR89140KIT. **\$769.00**
15".....KIR89150KIT. **\$769.00**
16".....KIR89160KIT. **\$769.00**
17".....KIR89170KIT. **\$769.00**
18".....KIR89180KIT. **\$789.00**

Designed for:
Sprints &
North East
Dirt Modifieds

Brackets and Mounts

Rear Seat Mounts.....KIR99208....**\$35.49**
A Frame Mt 1-1/4 C Plates Pair ..KIR99215....**\$26.39**

56LW Series 10° Layback



Strategically placed flared openings to lighten and strengthen seat. TIG welded .100" 5052 grade aluminum. MIG welded inside for added strength. Offset aluminum extrusion around perimeter of seat for added rigidity. Progressive rib bead adds extra strength. Upholstery is double stitched around belt openings and all stress points. Multi-position lap belt openings for easy mounting. Submarine belt opening is standard. Machine plate added to reinforce shoulder belt openings. Seat back is double cross broke for added strength and comfort. High density foam on rib supports for added comfort.

Designed for:
Asphalt Midget
Dirt Midget
Sprints



Seat	Tweed Cover
14".....KIR56100LW \$328.42	KIR58111LW \$126.49
15".....KIR56300LW \$328.42	KIR58311LW \$126.49
16".....KIR56500LW \$328.42	KIR58511LW \$126.49
17".....KIR56700LW \$328.42	KIR58511LW \$126.49

MINI SPRINTS & QTR MIDGETS

37 Series Micro Mini Sprint 10° Layback Containment Seat

Designed for:
Micros
Mini Sprints

Unique 3 part design for max vertical customization. Seat has 3" of vertical torso & shoulder height adjust. Head restraint has 2" of vertical adjustment, 1-1/2" of lateral adjust. Head restraint has 1/2" horizontal adjust so Right Head Pad can be moved. Head can be rotated down for additional peripheral vision. Works with all head & neck restraints. Comes w/99216, 1" C-Clamps for add head restraint support. 270 Micro Sprints use 40 Series Kit.



12"KIR37120KIT **\$639.00**
13"KIR37130KIT **\$639.00**
14"KIR37140KIT **\$639.00**
15"KIR37150KIT **\$639.00**
16"KIR37160KIT **\$639.00**

50 Series LW 10° Layback Mini Sprint

Detachable Left Front section of seat allows seat to be used for all classes of Micro Sprints. Strategically placed flared openings save weight & add strength.

Designed for:
Micros
Mini Sprints

Seat	Cover
13".....KIR50130 \$299.30	KIR5013011 \$81.99
14".....KIR50140 \$299.30	KIR5014011 \$81.99
15".....KIR50150 \$299.30	KIR5015011 \$81.99
16".....KIR50160 \$299.30	KIR5016011 \$81.99



24 Series 8° Layback Child Seats

Designed for:
Quarter Midgets

All of Kirkey smaller sized seats are designed and manufactured with the same care and attention to detail as our other professional racing seats.

Seat	Vinyl Cover
10".....KIR24900 \$113.75	KIR24901 \$99.65
11".....KIR24100 \$113.75	KIR24101 \$99.65
12".....KIR24200 \$113.75	KIR24201 \$99.65
13".....KIR24300 \$113.75	KIR24301 \$99.65
14".....KIR24400 \$113.75	KIR24401 \$99.65



34 Series Child Adj Contain

It is intended to give kids the safety of a full containment seat at an affordable price. Designed for TQ Midgets, Slingshots and other entry level classes for kids.

12".....KIR34120KIT **\$509.00**
14".....KIR34140KIT **\$509.00**



Child Head Support

Right KIR00100C...**\$24.12**
cover KIR00101C...**\$15.87**
Left KIR00200C...**\$24.12**
cover KIR00201C...**\$15.87**



MODIFIEDS, STREET STOCKS

88 Series Intermediate 18° Layback Containment Seat

Constructed from TIG welded .100" 5052 grade aluminum. Additional MIG welding adds strength. Contoured elongated bottom reinforced for added thigh and hip support. Rear Seat mount KIR99208.

Seat & Cover Combo
14".....KIR88140KIT **\$769.00**
15".....KIR88150KIT **\$769.00**
16".....KIR88160KIT **\$769.00**
17".....KIR88170KIT **\$769.00**
18.5".....KIR88185KIT **\$789.00**

Designed for:
Dirt Late Model,
Asphalt Late Models,
Midwest Modifieds,
Street Stock,
Crate Late Models.



70 Series Std 20 Deg Layback Containment Seat

Our std 20° layback containment seat is designed for the low horse powered short track race car. Designed for short track racing. seat and cover combo **\$499.59**

Seat & Cover Combo
13".....KIR70130KIT **\$499.59**
14".....KIR70140KIT **\$509.00**
15".....KIR70150KIT **\$509.00**
16".....KIR70160KIT **\$509.00**
17".....KIR70170KIT **\$509.00***

Designed for:
IMCA Modified
Street Stock



58 Series LW 20° Layback

Racers who want to save weight but demands the ultimate in comfort & safety.

Tweed Cover
14".....KIR58100LW **\$328.42** KIR58111LW **\$126.49**
14.5".....KIR58200LW **\$328.42** KIR58311LW **\$126.49**
15".....KIR58300LW **\$328.42** KIR58311LW **\$126.49**
15.5".....KIR58400LW **\$328.42** KIR58311LW **\$126.49**
16".....KIR58500LW **\$328.42** KIR58511LW **\$126.49**
16.5".....KIR58600LW **\$328.42** KIR58511LW **\$126.49**
17".....KIR58700LW **\$328.42** KIR58511LW **\$126.49**

Designed for:
Dirt Late Models
IMCA Modified
Street Stock



38 Series 20° Layback NEW

Unique bottom design allows seat to be mounted in multiple layback angles without raising center of gravity in the race car. Front of seat raised for leg and thigh support. Seat comes std with lap belt openings, dbl shoulder belt openings & sub belt opening to works with all belts.

Seat
14".....KIR38140. **\$163.98**
15".....KIR38150. **\$163.98**
16".....KIR38160. **\$163.98**
17".....KIR38170. **\$163.98**
18.5".....KIR38185. **\$178.91**
20".....KIR38200. **\$178.91**

Tweed Covers
KIR3814011. **\$105.06**
KIR3815011. **\$105.06**
KIR3816011. **\$105.06**
KIR3817011. **\$105.06**
KIR3818511. **\$116.12**
KIR3812011. **\$104.29**

Designed for:
Dirt Late Models
IMCA Modified
Street Stock



78 Series Intermediate 18° Deluxe Layback Containment Seat SFI 39.2

Seat passes SFI 39.2 Certification. Rear Seat mount available. (part # 99208).

Seat & Cover Combo
14".....KIR78140KIT **\$1429.00**
15".....KIR78150KIT **\$1429.00**
15.5".....KIR78155KIT **\$1429.00**
16".....KIR78160KIT **\$1429.00**
17".....KIR78170KIT **\$1429.00**

Designed for:
Dirt Late Model,
IMCA, Legend,
Street Stock



DRAG RACING



55 Series NEW Pro Street Drag 18°



The 55 Series seat has the same fit and feel as the 41 Series, slight changes to bottom allows this version to be mounted in a wide range of layback angle without raising center of gravity in the race car. Use of .100" thick alum throughout the seat has reduced weight up to 1/2 pound, (varies by size).

Seat	Cloth Cover
15".....KIR55150 \$151.35	KIR5515011 \$117.65
16".....KIR55160 \$151.35	KIR5516011 \$117.65
17".....KIR55170 \$151.35	KIR5517011 \$117.65
18.5".....KIR55185 \$166.48	KIR5518511 \$128.52
20".....KIR55200 \$166.48	KIR5520011 \$128.52

16 Series Econo 20° Drag



Designed for low horse power cars on small tracks. Seat side lowered for lap belts. MIG welded .125" think 5052 grade aluminum. Progressive rib bead adds extra strength. Seat bottom is contoured to support lower back and hips. Submarine and shoulder belt opening is std. Rubber moulding around perimeter of seat. Extra thick, high density foam padding on bottom to support thighs. Extra padding added in rib area for safety and comfort. Upholstery is double stitched around belt openings and all stress areas.

Seat	Tweed Cover
15.5".....KIR16400 \$127.40	KIR16411 \$108.61
17.5".....KIR16800 \$127.40	KIR16811 \$108.61

19 Series Economy 10° Layback



Designed for low horse power cars on small tracks. Seat side lowered for lap belts. MIG welded .125" think 5052 grade aluminum. Progressive rib bead adds extra strength. Seat bottom is contoured to support lower back and hips. Submarine and Shoulder belt opening is standard. Rubber moulding around perimeter of seat. Headrest reinforced with offset aluminum extrusion. Upholstery is double stitched around belt openings and all stress areas. Double rib support. 14.5" seat uses the same cover as the 15.5" seat.

Seat	Cover
14.5".....KIR19200 \$127.40	KIR09401 \$99.19
15.5".....KIR19400 \$127.40	KIR09401 \$99.19
17.5".....KIR19800 \$127.40	KIR09801 \$99.19

ROAD RACING

45 Series Deluxe 18° Layback Road Race Containment

For Drag Cars & Road Race Constructed from TIG welded .100" thick 5052 grade alum. MIG welded inside for added strength. Reinforced rib and shoulder restraints have high density padding for more protection & comfort. Shoulder and head restraint symmetrically designed for unobstructed peripheral vision and comfort. Designed to accommodate 6 point seat belts. Padded full cover for comfort and safety.



Seat	Black Cloth Cover
15".....KIR45300 \$535.63	KIR45341 \$263.45
16".....KIR45500 \$535.63	KIR45541 \$263.45
17".....KIR45700 \$535.63	KIR45741 \$263.45
18".....KIR45900 \$535.63	KIR45941 \$263.45

	
KIR99203	KIR99201

Brackets and Mounts
Aluminum Floor Seat MountKIR99203**\$69.07**
Rear Seat Mount.....KIR99201**\$35.04**

71 Series Standard 20° Road Race Containment Seat



Our standard 20 Degree layback containment seat is designed for the low horse powered short track road race car. Designed to give you more value for your money. Designed for entry level road racing. Available in sizes 14" to 17". Built in head and shoulder restraints. Designed to accommodate all head and neck restraints. Seat height can be adjusted 1" higher or 1" lower cover available in black cloth only.



Seat	Cloth Cover
14".....KIR71100 \$392.21	KIR71111 \$135.59
15".....KIR71300 \$392.21	KIR71311 \$135.59
16".....KIR71500 \$392.21	KIR71511 \$135.59
17".....KIR71700 \$392.21	KIR71711 \$135.59

47 Series Intermediate 15° Layback Road Race Seat

It is designed especially for entry level road course cars. It has the same quality construction as our Deluxe seat at an affordable price. This seat is very comfortable making it ideal for endurance events. Built with reinforced alum. Added lateral support for high G cornering.



Seat	Air Knit Cover
15".....KIR47300 \$219.40	KIR47341 \$262.99
16".....KIR47500 \$219.40	KIR47541 \$262.99
17".....KIR47700 \$219.40	KIR47741 \$262.99
18".....KIR47900 \$217.10	KIR47941 \$262.99



Seat Brackets
Upper bracketsKIR99212.....**\$36.35**
Lower bracketsKIR99214.....**\$45.45**

65 Series Adjustable Road Race Seat

Kirkey's new versatile Adjustable Road Race Seat can be used for Kit Cars, Club Racing and even Drag Racing. Vertically adjustable 2-1/2" for customization. Bottom designed for multiple layback angles. (18 to 23 degrees). Extra padding throughout black air knit cover for added comfort. Cover designed to accommodate leg supports. (02100-02200). Uses 99212 (rear) and 99214 (bottom) seat mounts.



Seat and Cover
15".....KIR65150KIT \$439.00
16".....KIR65160KIT \$439.00
17".....KIR65170KIT \$439.00
18-1/2".....KIR65185KIT \$465.00



Brackets and Mounts
Aluminum Floor Seat Mount...KIR99212**\$36.35**
Rear Seat MountKIR99214**\$45.45**

ASPHALT

73 Series 15° Layback Full Containment Asphalt

Replaces 53 series seat. Reinforced vertically adj head restraint with SFI 45.2 high-impact padding. Pre-punched shoulder mounting locations for easy installation. No square corners on bottom. Molded rubber inserts for lap and sub belt openings. Black air knit cover. Contoured bottom foam on cover has built-in leg separator for high g-force cornering support.



Seat & Cover Combo
14".....KIR73140KIT \$1239.00
15".....KIR73150KIT \$1239.00
16".....KIR73160KIT \$1239.00
17".....KIR73170KIT \$1239.00
18".....KIR73180KIT \$1239.00

92 Series SFI 39.1 Asphalt Modified Containment Seat

Kirkey Racing Fabrications most advanced aluminum seat to date. Designed to pass the stringent SFI 39.1 certification and NASCAR touring series rules. Easy installation and reasonable cost make this an easy choice for any racer.

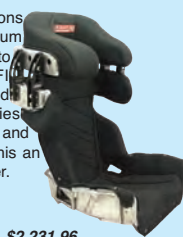

Seat
CustomKIR92000 \$2,231.96

Cover for
KIR92000 ..KIR92051**\$571.21**



Mini Pro Stock

Perfect for drag sedans. 30.25" high and 18.75" wide. Provisions for 5-way belts built into seat and cover.



Bare Seat	JAZ100-110-01	\$87.05
Vinyl Cover	JAZ150-111-01	\$65.39

Pro High Back

Perfect for trucks or drag sedans. Deep bucket and lateral support. 34" high and 20.75" wide. Provisions for 5-way belts built into seat and cover.



Bare Seat	JAZ100-140-01	\$94.80
Vinyl Cover (shown)	JAZ150-141-01	\$77.01

Turbo Pro

Designed for road racing and off road. Wrap around lateral support in shoulder and thigh area for high speed cornering. Molded in 5/16" x 18 threaded inserts. Compatible with 5 point harnesses. Black vinyl cover standard.



Bare seat	JAZ100-150-01	\$94.80
Vinyl Cover (shown)	JAZ150-151-01	\$82.82

STREET

09 Series Econo 20° Layback

Our most inexpensive seat has the same quality as our most expensive! Our layback designs offers extra headroom for all chassis & entry level racing classes.

seat **\$127.40** vinyl cover **\$71.89**

Seat	Vinyl Cover
14.5"....KIR09200 \$127.40	KIR09401 \$99.19
15.5"....KIR09400 \$127.40	KIR09401 \$99.19
17.5"....KIR09800 \$127.40	KIR09801 \$99.19



55V Series Vintage Class Bucket Seat

Same fit as the 41V Series with slight changes to the bottom which allows it to be mounted in a wide range of layback angles without raising the center of gravity. The addition of punched flared holes reduces weight and gives the seat a true "Rat Rod" look.

Seat	Cover
15"....KIR55150V \$190.65	KIR5515001V \$126.95
16"....KIR55160V \$190.65	KIR5516001V \$126.95
17"....KIR55170V \$190.65	KIR5517001V \$126.95
18"....KIR55185V \$190.65	KIR5518501V \$126.95



ACCESSORIES



Sprint/Midget Leg Protector

Lightweight alum formed to surround center steering unit. Fire retardant foam eliminates bulky cover.

Sprint Leg Protector.....KIR99500**\$65.95**
Midget Leg ProtectorKIR99502**\$65.95**

Center Steering Leg Protector Attaches to Seat

Full containment knee guard. Keeps your knees from getting banged up in a crash. This padded aluminum knee guard bolts or dzuses directly to your seat which makes it easy to remove in a hurry. Lightweight and safe. KIR99600.....**\$65.95**



Center Steer Padded Knee Guard

Fits Profile Steel and Alum, and GME Steel and Alum boxes. (may also fit others). Simple to install- 2 hose clamps install around box side tubes. Constructed from .100" Aluminum and TIG welded for strength. Completely padded for safety around the knees. Has clearance for large (2kw) inboard starter. Will clear Winters and Bert shifter linkages. BRP9046...**\$95.60**

Sliding Seat Mounts

NHRA accepted. For use with Universal Mts. JAZ450-011-03...**\$43.56**

Universal Mounts

NHRA accepted. Predrilled for 9 seat height and angle adjustments. JAZ450-010-09...**\$33.17**



KIR99212

Seat Brackets

Mounts seat to existing roll bar tubes. Specially designed for our road race seat, but can also be used with any seat.

Aluminum Floor Seat Mount...KIR99212.....**\$36.35**
Rear Seat MountKIR99214.....**\$45.45**

Molded Foam Seat Insert Kit

Designed to add form-fitting high-density padding to your current seat's bottom & lower lumbar, Kirkey's Molded Foam Seat Insert creates a custom fit for better support. Please note this kit is meant to be used with a seat that properly fits the driver as is. If the seat is too large for you already, you will need to purchase a 2nd kit. Kit includes all necessary materials:

- 2 containers of foam (Part A & B)
- 1/4" Foam Sheet
- 1 Roll Dbl-Sided Adhesive Gaffers Tape
- Foam Mixer
- Electric Knife
- Plastic Bag - Checklist
- Seat Cover Material
- KIR99300...**\$257.60**



Window Net Mounts

Heavy duty latch style mount kit with mounting tabs. 29" long rod.

Round Style ..JAZJAZ-908-03 ..**\$48.56**



Clamp-On Net Kit

Clamp-On Kit eliminates welding. Designed to clamp the ALL10219 Kit to chassis tubing. Kit for 1-1/2" Tubing....ALL10221.....**\$41.99**
Kit for 1-3/4" Tubing....ALL10222.....**\$41.99**



Spring-Loaded Round Tube

It eliminates the latch release and provides easy entry and exit. Pushing against the handle releases or fastens window net. Complete with top spring tube, 3/4" flat alum for bottom of net, chassis mounting hardware, handle and instructions. ALL10219.....**\$28.99**

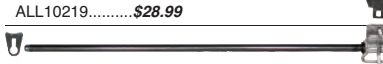

Latch Type Round Bar

Lever latch release has a 7/16" round upper support rod for use with border style nets. Brackets are included. ALL10217.....**\$41.99**



Latch Type Flat Bar

It is the lever latch release type used in most circle track or drag cars. 1" x 3/16" x 29" steel bar securely anchors the window net. Complete with mounting bracket.

Window Net Kit Latch.....ALL10218.....**\$45.99**
Replacement Mounting Tabs...ALL99070.....**\$8.99**

Accessories for Standard Seat

Head Support

tweed cover
right KIR00100...**\$24.12**
cover KIR00111...**\$15.87**
left KIR00200...**\$24.12**
cover KIR00211...**\$15.87**

Shoulder Support

tweed cover
right KIR00500...**\$32.12**
cover KIR00511...**\$19.87**
left KIR00600...**\$32.12**
cover KIR00611...**\$19.87**

Leg Support

tweed cover
right KIR00300...**\$31.40**
cover KIR00311...**\$17.61**
left KIR00400...**\$31.40**
cover KIR00411...**\$17.61**



Head Restraint Pad 1"

68/69 Series - Black Tweed
KIR68HP111.....**\$35.09**

Rear Seat Mount Aluminum for 73 & 91 Series

Rear mount for the 73 and 91 series. Attaches to the rear of the seat and then connects to the roll cage. Some fabrication required. KIR99209.....**\$63.65**

High Density Foam Sheet

Foam Sheet -.5" Peel & Stick 16" x 54"
KIR99401.....**\$25.55**

Leg Restraint Aluminum

For 68, 69, 70, 71, 73 Series.
Padded deluxe leg restraint can be bolted to 68-69-70-71-73 Series seats. This increases side support to the leg under heavy cornering and especially in case of a side impact. Comes with hardware to mount to seat. Restraint is made out of the same grade of aluminum as seat and can be ordered in any of the standard fabrics and colors listed with each seat. Substitute the last two numbers in the support part number with the appropriate fabric & color number.
Left SideKIR02200**\$36.26**
Right Side.....KIR02100**\$36.26**

Rear Seat Mount - 3/16" Aluminum for 70 & 71 Series Seat

Rear mount for the 70 and 71 series seats. Constructed using 3/16" high quality aluminum. Bolts to the rear of the seat and then connects to the roll cage. Never mount to sheet metal. Some fabrication required.

KIR99211.....**\$36.35**

Lumbar Support

Dense foam supports your lower back. Includes snaps and rivets for installation into your aluminum seat. KIR99020.....**\$16.99**

Foam

3/4" Thicker Right Side Foam
KIRFOAM79HRWIDE ..**\$87.49**
Left Side Foam
KIRFOAM89HLS.....**\$41.33**
Right Side Foam
KIRFOAM89HRS**\$74.91**





The same race-proven movements used in our original Sport-Comp gauges, this series add superior White LED through the dial lighting technology and glowing red pointers.

2-5/8" Digital Stepper Motor Gauges w/Peak & Warning

- Fuel Pressure 0-15 PSI.....AUT7661 **\$259.95**
- Fuel Pressure 0-100 PSI.....AUT7663 **\$259.95**
- Nitrous Pressure 0-1600 PSI.....AUT7674 **\$259.95**
- Oil Pressure 0-100 PSI.....AUT7653 **\$259.95**
- Water Temp 100°-260° F.....AUT7655 **\$195.95**
- Oil Temperature 140°-340° F.....AUT7656 **\$194.95**



Born on the ovals of NASCAR and refined on road courses & drag strips around the world, Spek-Pro gauges are the most advanced instruments ever conceived. Bright 7 color LED lighting, configurable warning points, and peak recall make sure you stay focused on the task at hand. Pro Control outputs allow the gauges to control vehicle function at predetermined points. Digital stepper motor design & motorsport grade sending units provide superior accuracy.

5" Tach, 11,000 RPM, SPEK

Size: 2-1/16" (52.4mm)
Type: Digital Stepper Motor Range: 0-11,000 RPM. The patented air core meter movement, wound in house to exacting standards, can move the needle from 0 - 10,000 rpm in 333 milliseconds.
AUTP239328....**\$397.88**



2-1/16" Digital Stepper Motor Gauges

- Fuel Pressure 0-15 PSI.....AUTP315328 **\$253.43**
- Oil Pressure 0-120 PSI.....AUTP325328 **\$253.43**
- Oil Temp 100°-300° F.....AUTP322328 **\$213.67**
- Water Temp 100°-300° F.....AUTP346328 **\$213.67**



SPORT-COMP

5" Pedestal Mount Tach

8,000 RPM. w/ external amber shift light...AUT3905..**\$289.95**

10,000 RPM w/Amber Light on Shield..AUT3903..**\$289.95**

10,000 RPM w/ Adj Redline Pointer.....AUT3900..**\$199.95**

Autogage

5" Monster Shift-Lite Tachs

With external Shift Lite
10,000 RPM ..AUT233904...**\$193.16**
8,000 RPMAUT233905...**\$193.16**

Standard
10,000 RPM ..AUT233902...**\$196.57**

PRO-COMP

5" Pedestal Mount Memory Tachs

Features Memory to recall highest RPM.
9,000 RPM...AUT6809...**\$299.95**
11,000 RPM.AUT6811...**\$299.95**

3-3/4" Pedestal Mount Tach

10,000 RPM. Features memory and with remote mounted memory switch.
AUT6601..**\$319.95**

5" In-Dash Electric Tach

10,000 RPM. Features memory to recall highest RPM.
AUT6801..**\$339.95**

EXTREME ENVIRONMENT Auto Meter



2-1/16" Extreme Environment Gauges

They feature a waterproof design that is sealed front and rear for protection against the elements in exposed cockpits. These gauges have a smart full dial color change digital alarm circuit ensures visibility in any lighting condition.

- Oil Temperature 100°-340° F.....AUT9240..**\$169.95**
- Oil Pressure 0-120 PSI.....AUT9253..**\$199.95**
- Water Temp 100°-300° F.....AUT9255..**\$169.95**
- Fuel Pressure 0-15 PSI.....AUT9261..**\$199.95**

Mounting Cups

2-5/8" Autometer & Autogage

For use with all 2-5/8" Mechanical Temp and Pressure Gauges.
AUT3203.Chrome...**\$39.95**
AUT3204.Black.....**\$24.95**



2-5/8" Pro-Comp Liquid-Filled

For use w/Liquid-Filled Pressure & Temp Gauges (except brake pressure)
AUT5202..Black.....**\$28.95**

Digital Pro Shift System Shift Light, Level 1

Size: 2 1/16" (52.4mm) • Range: 0-15k RPM (.5 - 6 Pulse Ignitions) LED digital display. Single stage programmable "super-bright" shift light with user selectable dimming. Operates on most 4, 6, 8, 10, & 12 cyl engines with points, electronic, DIS & most 12V high perf racing ignitions.
AUT4387....**\$199.95**



ULTRA-LITE 5" In-Dash Tachs

10,000 rpm Dual Range w/Memory....AUT4499..**\$339.95**

10,000 rpm w/Memory
AUT4494..**\$339.95**

10,000 rpm for In-Dash Mounting.....AUT4498..**\$214.95**



TEL TAC II Digital Tach

It is a self-contained digital tach with built-in memory recall. Compact 3-1/8" x 3-1/8" size is easy to mount. Extremely rugged construction allows it to perform in almost any racing environment. Tel Tac II recalls and displays the highest overall RPM for up to 30 minutes after the car is shut off. Tel Tac Oval Track Pro shows the highest overall RPM, the four lowest RPMs and the four highest RPMs from two laps. This allows you to tune your car correctly, not guess. Powered by common 9 volt battery. The tach works on 4, 6 and 8 cylinder engines with either magnetos or distributors. This tach is not lighted.
TELTACH.....**\$304.00**

Oval Track Pro Digital Tach

Self-contained digital tach with built-in memory. Small, easy to mount. Memory display lasts 30 minutes after car is shut off. Powered by 9 volt battery. 3 1/8" x 3 1/8" dimensions. Works on 4-6-8 cylinder mags or distributors. Max. RPM reading: V8 up to 12,000 rpm 4 and 6 cylinder up to 15,000 rpm. Tel Tac Oval Track Pro shows the highest overall RPM, the four lowest RPM's and the four highest RPM's from 2 laps. This allows you to tune your car correctly, not guess.
TELOTP.....**\$439.99**

Wiring Harness

Wiring harness can be utilized for use of Tel Tac in multiple cars, or simply as a replacement harness.

TEL1001.....**\$30.95**



Autogage

Street & performance tachs and gauge consoles for the budget minded enthusiast.



ULTRA-LITE

Born on the high speed ovals of NASCAR and refined in motor-sport competition throughout the world, it's no surprise the Ultra-Lite gauges have become the most popular series in the Auto Meter line. The use of lightweight materials and engineered to near bulletproof standards, the matte brushed aluminum dial and bezel look clean and right at home in any application. More professional racers trust Ultra-Lites than any other gauge.



SPORT-COMP

An industry icon since the 1970's, our Sport-Comp gauges reinvented performance gauges as we know it. A clean, easy to read design, highly ruggedized movements built to withstand sportsman competition. A purpose built line of gauges designed and built to accomplish the singular mission of providing the most accurate information possible to the driver. At home on the street as they are on the track, the timeless design is the finishing touch to set off any serious build.



ULTRA-NITE

Glow in the dark dial faces provide limited duration visibility for night races while minimizing instrument weight. These products have no provisions for back-lighting.



Glow In The Dark



PRO-COMP

The most rugged gauges available, these tough liquid filled mechanical gauges have more than 20 years of race proven heritage in the most extreme conditions.



Glow In The Dark



2-5/8" Mech Gauges

	Autogage	Sport-Comp	Ultra-Lite	Ultra-Nite	Pro-Comp
Blower Pressure 0-60 PSI	-----	AUT3402 \$89.95	AUT4402 \$89.95	-----	AUT5402 \$102.95 AUT5403 \$149.95
Blower Pressure w/Memory 0-60 PSI.....	-----	-----	-----	-----	-----
Brake Pressure 0-2000 PSI.....	-----	-----	AUT4426 \$119.95	-----	AUT5426 \$129.95
Boost/Vacuum 30 IN. HG / 20 PSI.....	AUT2310 \$50.65	AUT3401 \$89.95	AUT4401 \$89.95	-----	AUT5401 \$102.95
Boost/Vacuum 30 IN. HG / 30 PSI.....	-----	AUT3403 \$89.95	AUT4403 \$89.95	-----	-----
Fuel Pressure 0-15 PSI.....	AUT2311 \$50.65	AUT3411 \$73.95	AUT4411 \$78.95	AUT4511 \$82.95	AUT5411 \$99.95
Fuel Pressure 0-100 PSI	-----	AUT3412 \$78.95	AUT4412 \$78.95	-----	AUT5412 \$99.95
Fuel Pressure with Isolator 0-15 PSI	-----	AUT3413 \$189.95	AUT4413 \$189.95	-----	AUT5413 \$209.95
Oil Pressure 0-100 PSI	AUT2312 \$50.65	AUT3421 \$78.95	AUT4421 \$82.95	AUT4521 \$82.95	AUT5421 \$99.95
Oil Pressure 0-150 PSI	-----	AUT3423 \$78.95	AUT4423 \$82.95	AUT4523 \$89.95	-----
Oil Pressure 0-200 PSI	-----	AUT3422 \$78.95	AUT4422 \$82.95	-----	AUT5422 \$99.95
Oil Temp 100°-340°F	AUT2314 \$56.62	-----	-----	-----	-----
Oil Temp 140°-280°F 6' Tubing	-----	AUT3441 \$107.95	AUT4441 \$114.95	AUT4541 \$125.95	AUT5441 \$139.95
Oil Temp 140°-280°F 12' Tubing.....	-----	AUT3443 \$114.95	-----	-----	AUT5443 \$149.95
Transmission Temp 140°-280°	-----	AUT3451 \$104.95	AUT4451 \$114.95	-----	AUT5451 \$137.95
Vacuum 30 IN. HG	AUT2317 \$49.66	AUT3484 \$76.95	AUT4484 \$81.95	-----	AUT5484 \$99.95
Water Temp 100°-280°F.....	AUT2313 \$56.62	-----	-----	-----	-----
Water Temp 120°-240°F 6' Tubing	-----	AUT3432 \$104.95	AUT4432 \$118.95	AUT4532 \$129.95	AUT5432 \$139.95
Water Temp 120°-240°F 12' Tubing	-----	AUT3433 \$114.95	AUT4433 \$119.95	-----	AUT5433 \$139.95
Water Temp 140°-280°F 6' Cap Water Res.....	-----	AUT3431 \$104.95	AUT4431 \$115.95	AUT4531 \$119.95	AUT5431 \$139.95
Water Temp 140°-280°F 4' Cap Water Res.....	-----	-----	-----	AUT4535 \$121.95	-----
Temperature 140°-340°F	-----	-----	AUT4435 \$119.95	-----	AUT5435 \$139.95

2-1/16" Mech Gauges Autogage

	Autogage	Sport-Comp	Ultra-Lite
Boost/Vacuum 30 IN. HG / 20 PSI	-----	AUT3301 \$76.95	AUT4301 \$76.95
Boost/Vacuum 30 IN. HG / 30 PSI	-----	AUT3303 \$76.95	AUT4303 \$76.95
Fuel Pressure 0-15 PSI	-----	AUT3311 \$72.95	AUT4311 \$72.95
Fuel Pressure 0-100 PSI	-----	AUT3312 \$72.95	AUT4312 \$72.95
Fuel Pressure with Isolator 0-15 PSI.....	-----	AUT3313 \$184.95	AUT4313 \$189.95
Oil Pressure 0-100 PSI.....	AUT2332 \$37.73	AUT3321 \$74.95	AUT4321 \$74.95
Oil Pressure 0-150 PSI.....	-----	AUT3323 \$74.95	AUT4323 \$74.95
Oil Pressure 0-200 PSI.....	-----	AUT3322 \$74.95	AUT4322 \$74.95
Oil Temp 140°-280°F.....	-----	AUT3341 \$99.95	AUT4341 \$99.95
Vacuum 30 IN. HG.....	AUT2337 \$42.44	AUT3384 \$72.95	AUT4384 \$72.95
Water Temp 100°-280°F.....	AUT2333 \$45.68	-----	-----
Water Temp 120°-240°F 6' Tubing	-----	AUT3332 \$99.95	AUT4332 \$99.95
Water Temp 120°-240°F 12' Tubing	-----	AUT3333 \$104.95	AUT4333 \$115.95
Water Temp 140°-280°F.....	-----	AUT3331 \$99.95	AUT4331 \$99.95
Transmission Temp 140°-280°	-----	AUT3351 \$104.95	AUT4351 \$104.95



Longacre

AccuTech SMi Gauges

SMi Stepper motor gauges use a small electronic motor that only turns a tiny fraction of a rotation to drive the pointer. It is electronically controlled and is much more precise than the traditional mechanical instruments whose accuracy can be affected by many factors. Many professional race teams - NASCAR, etc. - are switching to this style of gauge for the improved accuracy (see the in-car cameras). Approved for use by IMCA.

Oil Pressure	0-100 psi	LON46540	\$153.62
Fuel Pressure	0-15 psi	LON46535	\$153.62
Fuel Pressure	0-100 psi	LON46538	\$153.62
Fuel Pressure	100-280 psi	LON46545	\$105.62
Water Temp	100-340 psi	LON46548	\$105.62
Oil Temperature	100-340 psi	LON46553	\$105.62
Oil Temperature	100-280 psi	LON46550	\$105.62

AccuTech Sportsman

Affordable economy steel case gauges. Solid brass CNC machined gears and industry std mechanisms. Viscous damped pointers for steady readings. Gauges come complete with back lights, temp manifold fittings, bkts & self-locking nuts. 2-5/8" mech gauges.

Fuel Pressure	0-15 psi	LON46506	\$32.91
Oil Pressure	0-100 psi	LON46506	\$32.91
Oil Temperature	0-340 psi	LON46521	\$41.16
Water Temperature	0-280 psi	LON46516	\$41.16



4 Gauge Alum Panel w/ Sportsman Gauge OP,WT,OT,FP

Pointers are viscous damped for steady readings. Gauges have CNC machined solid brass gears. Industry std fittings and connections. Pre-wired with "Fat" wiring and soldered heat-shrink terminals. Sharp looking aluminum panel...black anodized with clean, cool graphics. Warning lights and all senders are included. 2 5/8" mech gauges with NEW style graphics and back lights. Black LON44435\$196.96



3 Gauge Aluminum Panel w/ Sportsman Gauges OP,WT,OT

Pointers are viscous damped for steady readings. Gauges have CNC machined solid brass gears. Industry std fittings and connections. Pre-wired with "Fat" wiring and soldered heat-shrink terminals. Sharp looking aluminum panel...black anodized with clean, cool graphics. Warning lights and all senders are included. 2 5/8" mech gauges with NEW style graphics and back lights. Black LON44431\$160.06



3 Gauge Aluminum Panel w/ Sportsman Gauges - OP,WT,FP

Pointers are viscous damped for steady readings. Gauges have CNC machined solid brass gears. Industry standard fittings and connections. Pre-wired with "Fat" wiring and soldered heat-shrink terminals. Sharp looking aluminum panel...black anodized with clean, cool graphics. Warning lights and all senders are included. 2 5/8" mechanical gauges with NEW style graphics and back lights. Black LON44433\$160.06

Seals-it

Dashboard Gauge Grommet Seal

2-1/16"	SEADB206-225	\$8.95
2-5/8"	SEADB206-275	\$9.95



2 Gauge Aluminum Panel w/ Sportsman Gauges - OP,WT

Pointers are viscous damped for steady readings. Gauges have CNC machined solid brass gears. Industry standard fittings and connections. Pre-wired with "Fat" wiring and soldered heat-shrink terminals. Sharp looking aluminum panel...black anodized with clean, cool graphics. Warning lights and all senders are included. 2 5/8" mechanical gauges with NEW style graphics and back lights. Black LON44430\$107.06



2 Gauge Sportsman w. AccuTech SMi Tach - OP,WT

Much more accurate than traditional "air core" tachs. Maximum RPM recall - Just push the Recall button. 2 stage High RPM Warning light. Helps prevent over-revving of expensive motors. Can also be used as a 2 stage shift light. LED back light - Back light shows through the dial face PLUS the pointer is LED illuminated to make this the easiest tach to read - and super sharp looking too. Black LON44440\$288.05



Flip-up Start / Ignition Panel with Pilot Light

Flip-up and Weatherproof Covers: Panel includes both aircraft style flip-up and silicone rubber weatherproof ignition switch covers - easily changed to match your preference. **Easy to Install:** Panel comes pre-wired for an easy installation - even easier with Heavy Duty Wiring Harness 44930. Panel can be mounted directly to your dash or to your roll bar with Mounting Brackets 22783 or 22787.

Matching Graphics: Clean modern graphics match our 2015 gauge and battery disconnect panels. High capacity (40 amp at 12 volts DC) ignition switch with aircraft style cover and pilot light - Easy to turn off in an emergency from any angle, even with gloves. Will not turn off from vibration. Silicone rubber weatherproof ignition switch cover included - to keep out dirt and moisture. Starter button with weatherproof cover. Great looking Aluminum Panel - black anodized with clean, modern graphics. Pre-wired with high insulation "Fat" wires and soldered terminals with heat shrink connections. Plugs into Longacre wiring harness P/N 44930. Mounts to 1-3/4" or 1-1/2" roll bar with Longacre Bolt-On Mounting Brackets P/Ns 22783 or 22787. LON44863\$40.50



Flip-up Start / Ignition panel w/ 2 acc & pilot lights

High capacity (40 amp at 12 volts) ignition switch with aircraft style cover and pilot light - Easy to turn off in an emergency from any angle, even with gloves. Will not turn off from vibration. Silicone rubber weatherproof ignition switch cover included - to keep out dirt and moisture. Starter button with weatherproof cover. 2 acc switches with silicone rubber switch covers and pilot lights. Great looking Alum Panel - black anodized with clean, modern graphics. Plugs into wiring harness LON44930. Mts to 1-3/4" or 1-1/2" roll bar w/Bolt-On Mounting Bkts LON22783 or LON22787 LON44867\$60.46



Mini Brake Balance Panel



See exactly what your balance is. Panel comes w/ (2) 1-1/2" 1500 psi liquid filled gauges & fittings with bleeders. Panel dimensions - 7" x 3-1/2" Standard LON44124\$70.70 Carbon Fiber LON44128\$69.99

Battery Disconnect w/Panel 2 Terminal



Manual battery disconnect switch with a bright red handle. Easier to find in an emergency. Prevents battery drain. 175 amp continuous rating, 6-36 volt, 1000 peak. Great looking Aluminum Panel - black anodized with clean, modern graphics LON45760\$35.32

Battery Disconnect Switch only 4 Terminal



Required in NASCAR, SCCA, NHRA. Manual battery disconnect switch with a bright red handle. Easier to find in an emergency. Prevents battery drain. 175 amp continuous rating, 6-36 volt, 1000 peak. LON45780\$30.98

Weatherproof Battery Disconnect 4 Terminal



The back side of these switches are completely sealed and weatherproofed with a tough, waterproof polymer coating. Keeps out dirt, dust and moisture that can turn a critical switch into a useless dead end connection, possibly putting you out of a race. Battery disconnect required in NASCAR, SCCA, NHRA. LON45788\$45.03

AccuTech Digital Tach



Ultra lightweight - only about 1-1/2 ounces. 3-1/2" x 1-1/2". State of the art electronics give you accuracy to within 10 RPM. Fast response. Easy to read. Easy recall. High RPM warning light to help prevent over-revving of the engine. Uses CR2032 battery. 10,000 RPM LON44391\$192.02 19,000 RPM LON44402\$220.82

Water Pressure Warning Lite Kit



3.5-4.5 psi Alerts you to leaks in the cooling system. Prevents expensive engine damage. Kit includes sender, light, wire, and terminals LON40141\$28.86

Sprint Car Battery pack complete kit



For low oil pressure warning light. Includes holder for LW 9V battery, low oil pressure switch (20 psi), warning light, heavy duty mag kill switch w/ weatherproof switch cover, wire and terminals. LON45620\$36.00

Waterproof Switch Panels



Designed with the racer in mind, panels feature well marked switches and indicator lights. Units are completely wired for easy installation and include detailed instructions. w/o Light ALL80160\$42.99 With Light ALL80162\$48.99

Toggle Extensions



Push-on extensions are 1-7/8" long, offered in red or black and sold as a 2-pack. Black Extensions (2-Pack) ALL80168\$3.69



4 Gauge Panel

Oil Pressure, Water Temp, Oil Temp, and Fuel Pressure with isolator

Ultra-Lite.....QUA300-1400\$469.49



3 Gauge Panels

Oil Pressure, Water Temp, Oil Temp.

Ultra-NiteQUA300-2300\$347.24

Sport-Comp....QUA300-3300\$304.00

Pro-Comp.....QUA300-4300\$471.24

2 Gauge Panels

with Oil Pressure and Water Temp.

Ultra-NiteQUA300-2200\$284.58

Sport-CompQUA300-3200\$204.98



Three Gauge Panels

Oil Pressure., Water Temp., Oil Temp.

QUA310-5300.....\$159.50

2 Gauge Panels

Oil Pressure

and Water Temp.

QUA310-5200

\$105.11



Gauge Panel with Tach

2 Gauge Panel w/ 3-3/4" Tach OP-WT

QUA310-3210..\$408.80

3 Gauge Panel w/ 3-3/4" Tach OP-WT-OT

QUA310-3310..\$449.61

Terminal Block

4 locations with jumper.....QUA360-1263..\$9.95

5 locations with jumper.....QUA360-1261..\$9.95

6 locations with jumper.....QUA360-1262..\$9.95

Magneto Signal Converter

Converts mag signal to work w/standard ignition tach.

AUT9118...\$97.95

Black Aluminum Gauge Panel

For all 2-1/16" Autometer gauges.

2-Hole...AUT2237...\$21.95

For all 2-5/8" Aut gauges.

1-Hole...AUT3231...\$20.95

2-Hole...AUT3232...\$22.95

3-Hole...AUT3233...\$23.95

Temp Adapters

3/8" Brass NPTAUT2263\$10.95

1/2" Brass NPTAUT2264\$10.95

1/2" Alum. NPTAUT2273\$13.95

SWITCH PANELS

Just like Quantum's gauge panels, their switch panels feature soldered and heat shrunk connections. More reliability, less DNF's.

Ignition Switch Panel

A heavy duty rubber sealed push button for your starter and your choice a rubber sealed toggle, or flip cover safety switch.

Toggle for magneto.....QUA350-1505 ...\$32.50

Flip SwitchQUA350-1510 ...\$37.02

Flip Switch for mag.....QUA350-1515 ...\$42.50

Starter button, 1 Ignition & 2 Accessory Switches, 3 Indicator Lights

A heavy duty rubber sealed push button for your starter, 3 rubber sealed toggles and 3 red indicator lights.

Button, 3 Toggles w/ 3 Lights
QUA350-1555.....\$64.00

Starter Button, Ign & Acc. Switches w/ 2 Lights

A heavy duty rubber sealed push button for your starter and rubber sealed toggles each of which activates a red indicator light.

Button, 2 Toggles w/ 2 Lights
QUA350-1570...\$48.65

Starter Button, Ignition Switch w/Light

A heavy duty rubber sealed push button for your starter and a rubber sealed toggle which activates a red indicator light.

Toggle w/Light.....QUA350-1530 \$38.16

Toggle w/Light for mag.QUA350-1535 \$37.55

Battery Disconnect Switch

A high amperage on/off switch for ignitions with or without alternator.

Without Alternator
QUA350-1540\$34.32

With Alternator
QUA350-1545\$34.50

Battery Disconnect Switch Handle

Battery Disconnect Red Handle with screw

QUA360-1241\$6.00

1 Standard Ignition,
1 Starter Button,
and 3 Std Accessory
QUA350-1630...\$55.87

1 Standard Ignition,
1 Momentary Starter,
and 3 Std Accessory
QUA350-1631...\$53.07

1 Flip Ignition,
1 Starter Button,
& 3 Accessory Switch
QUA350-1635...\$59.56



Silver Face Gauges

Fuel Pressure 0-15 psi.....QUA310-2004 ..\$30.45

Oil Pressure 0-100 psi.....QUA310-2008 ..\$30.45

Water Temperature 100-280 degree ..QUA310-2012 ..\$39.95

Oil Temperature 100-340 degree ..QUA310-2016 ..\$39.95

Clear LED Gauge Light

QUA310-2000.....\$5.00

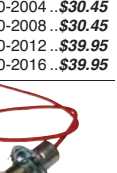

1 Starter Button,
1 Standard Ignition,
1 Accessory Switch,
and 2 Lites
QUA350-1570..\$48.65



1 Flip Ignition,
1 Starter Button,
1 Accessory Switch,
and 2 Lites
QUA350-1571...\$52.61



1 Starter Button,
1 Standard Ignition,
1 Parker Pumper,
and 3 Lites
QUA350-1572...\$56.09



1 Starter Button,
1 Standard Ignition,
2 Accessory Switch,
and 3 Lites
QUA350-1575...\$53.88



1 Flip Ignition,
1 Starter Button,
2 Accessory Switch,
and 3 Lites
QUA350-1576...\$55.90



1 Starter Button,
1 Std Ignition,
1 Parker Pumper,
1 Acc Switch, & 4 Lites
QUA350-1577...\$61.89



1 Standard Ignition,
and 1 Starter Button,
QUA350-1600..\$35.63



1 Flip Ignition,
and 1 Starter Button,
QUA350-1605..\$39.50



1 Standard Ignition,
1 Starter Button,
and 1 Std Accessory
QUA350-1610..\$42.50



1 Standard Ignition,
1 Momentary Starter,
and 1 Std Accessory
QUA350-1611..\$42.39



1 Standard Ignition,
1 Momentary Starter,
and 1 Dual Ignition
QUA350-1612..\$42.50



1 Flipping Ignition,
1 Starter Button,
and 1 Acc Switch
QUA350-1615...\$45.62



1 Standard Ignition,
1 Start Button,
and 2 Std Accessory
QUA350-1625...\$51.25



1 Standard Ignition,
1 Momentary Starter,
and 2 Std Accessory
QUA350-1621...\$43.43



1 Flip Ignition,
1 Starter Button,
& 2 Accessory Switch
QUA350-1625...\$54.39

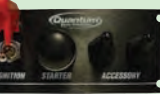

Bulbs & Sockets

Bulb and Socket No. 168/4.9 Watt
AUT3211\$7.95

For use with 2-1/16" and 2-5/8" gauges (steel cases)
Also used in some tachs and speedometers.

Replacement Bulb 3 Watt
AUT3216.....\$5.95

For use with most gauges; and some tachs and speedometers. Bulb and Twist In Socket No. 86
AUT3219.....\$7.95





Far Superior to Common Racing Designs

A stronger drive and more powerful 2.2 KW motor provide for your engine or vehicle. We recommend the TS100 series starters for engine or vehicle. We recommend the TS100 series starters for engines smaller than 420 CID & up to 14:5:1 compression. Chevy 168 tooth flexplate Std drive ..MEZTS100 ..\$355.13 Chevy 153 tooth flexplate Std drive ..MEZTS101 ..\$355.13



The Engine Builder's Choice.

Engines exceeding 540 CI, 632, or even larger are the norm. If this fits your description then we've got the prescription. Our TS400 design features a powerful 2.2 KW motor and a drive assembly specifically designed for extreme starting conditions. Virtually all of the power transmitting components have been scrutinized to bring you reliability unmatched by any other manufacturer.



Chevy offset for 168 tooth flexplate Super Duty drive.....MEZTS400\$540.90

Chevy offset for 168 tooth flexplate or 153 tooth flexplate Super Duty drive.....MEZTS400DP\$540.90

The TST400 Starter

Fits big and small block Chevy engines. It requires that you use this in conjunction with part # FPT flexplate (139 tooth "ten pitch"). It is mandatory that the two "ten pitch" components be used together, the starter and flexplate combination will install exactly like a normal 12 pitch (std Chevy) combination but will provide a deeper and stronger gear set.



Chevy offset for 139 tooth 10 pitch flexplate Super Duty drive.....MEZTST400\$540.90

Switches PAINLESS

On/Off Rocker Red LightPAI80401 ...\$15.99
On/Off Rocker Amber Light.....PAI80404 ...\$14.99
On/Off Rocker Blue Lighted.....PAI80405 ...\$15.99
On/Off/On Rocker Red Light.....PAI80403 ...\$19.99



Starter Button

Button w/Rubber Cover
PAI80503...\$20.99



Alternator Pulleys MOROSO

Single groove 5" dia pulley slows alt for high revving racing apps. Fits GM and Ford alts with 21/32" shaft. High grade cast alum ..MOR64800 ...\$36.88
Machined billet alum ...MOR64870 ...\$57.66



Alternator Mount Brackets

Designed to mt any GM Delcotron alt to SBC's & 90" V6. Early heads need to be drilled & tapped. MOR63825.....\$62.71



Chevy 168 Tooth Flywheel (Staggered Mount) Mastertorque

Weight: 10 lbs. • Torque @ peak HP: 180
POW9612.....\$208.48



Ford SB 289, 302, 351 W & C A/T & 5 Sp M/T (3/4" Offset)

Mastertorque 10 lbs. • Torque @ peak HP: 180 • Rated kw: 1.4
NaturalPOW9603.....\$198.50

XS Torque 8 lbs. • Torque @ peak HP: 200 • Rated kw: 1.4
NaturalPOW9503.....\$228.43
ChromePOW19503.....\$318.20



Mopar, Chrysler, Dodge, Plymouth 65-87

Mastertorque 10 lbs. • Torque @ peak HP: 180 • Rated kw: 1.4
NaturalPOW9613\$183.54

XS Torque 8 lbs. • Torque @ peak HP: 200 • Rated kw: 1.4
NaturalPOW9513\$228.43
ChromePOW19513\$338.15



'67-'69 Camaro/Nova Spacer Kit

It was designed for owners for '67-'69 Camaros that would like to install the 100 Amp Pro Series Kit POW8-881 but have a problem installing it with crossmembers. This spaces the crank pulley and bracket out 1", away from the crossmembers.....POW981.....\$48.88



Mil-Spec Momentary On-Off Switch

2 Screw w/Rubber Cover
QUA360-1209MIL-SPEC ..\$19.95



Mil-Spec On-Off Switch

2 Screw w/Rubber Cover
QUA360-1210MIL-SPEC ..\$19.95



Mil-Spec On-On Switch

3 Screw w/Rubber Cover
QUA360-1213MIL-SPEC ..\$21.40



Starter Button w/Rubber Cover

QUA360-1225.....\$10.28



#1 Seller



High Torque Starters

These Bsc starters are 35% smaller than OEM, yet have 50% more torque. Available in either 1.4Kw or 2.2Kw rating, both come with 3.75 reduction drive, & indexable mt so starter can be rotated, allowing for pan or header clearance. Dual bolt pattern fits either 153 or 168 tooth flywheel.

Fits straight bolt pattern blocks only!
HD Chevy 1.4KwSTAR1000\$149.95
HD Chevy 2.2KwSTAR1002\$161.95

NEW High Torque Starter with Clockable Mount

HD Chevy 180ft/lbs
STAR1003\$167.87



SBC Mini-Starter 1.4kw

It's smaller, lighter and has several mounting options. Perfect starter for circle track cars with clearance problems in the chassis or around header pipes. SBC 153 and 168 tooth applications. Note: Also fits BBC. ALL80520....\$159.99



Starter Solenoid

Ford-style solenoid is perfect for use with high torque racing starters. Flat base eases mounting, and a remote under hood starter switch or timing light hook-up can be easily adapted. ALL76203....\$13.99



Big Switch w/Extension Kit

This industrial lever allows for remote mounting of the Big Stick. The kit includes a custom 15" aluminum rod, handle and the switch. The switch is activated by turning action. FLAFR1003-4.....\$137.46



MSD Ignition Advanced Power System Starter

Gear reduction of 4.4:1 improves torque for great cranking. 3 horsepower motor provides power for high compression engines. Downsized design helps clearance issues with oil pans and exhaust. MSD5095.....\$296.95



Starter Saver w/Signal Stabilizer

Compact unit provides 10" or 20" of start retard to ease pressure on the starter & flywheel during cranking. Built-in LED monitors trigger input signals. Built-in signal stabilizer produces steady timing at all rpm. Must be used with an MSD Ignition Control, magnetic pickup trigger and only on V-8 applications. MSD8984.....\$133.95



Custom Lengths Available!



Battery Cables

Black

7" CableQUA802-0733BK.....\$11.86

9" CableQUA802-0933BK.....\$12.47

14" Cable ..QUA802-1433BK.....\$14.04

Red

20" Cable ..QUA802-2053RDC...\$16.56

25" Cable ..QUA802-2553RDC...\$18.00

37" Cable ..QUA802-3733RDC...\$21.46

40" Cable ..QUA802-4033RDC...\$22.32

52" Cable ..QUA802-5233RDC...\$25.78



3/16" Double Ended Drill Bits (6)

3/16"BSC90006\$6.00
1/8"BSC90007\$5.25



Thru Firewall Battery Connector

Black.....QUA360-1250....\$9.98
Red.....QUA360-1251....\$9.98



Battery Jumper Terminals

QUA360-1255..\$26.95



GM/Delco 10dn, 10si, 12si Alt

Natural "OE" Look
Amperage...Part #
80A.....POW8003 ...\$118.60
100A.....POW8002 ...\$129.58
140A.....POW47294 ...\$159.50



Chrome "OE" Look
Amperage...Part #
80A.....POW17127 ...\$144.54
100A.....POW17294 ...\$144.54
140A.....POW37293 ...\$181.45



BBC SWP Alt Kits

26.772" Long, 10mm Wide,
Radius Tooth Belt
JON680-10 HD. \$16.89



SBC SWP Alt Kits

26.457" Long, 10mm Wide,
Radius Tooth Belt
JON672-10 HD. \$16.78



Combination Battery & Alt Kill Switch

It is designed to completely shut down the battery and charging system in an emergency situation. Meets IHRA, NHRA & SCCA sanctioning body requirements
Rated Capacity: Battery - 2000 Amp Surge
• 150 Amp Continuous • Alt - 120 Amp
FLAFR1013.....\$79.92



The Little Switch - With Mounting Bkt

It is rated at 100 amps continuous service and 500 amps for 10 second. Competition approved by IMSA, ARCA, and SCCA.
• Prevents Battery Drain • Water Resistant
FLAFR1002.....\$34.15

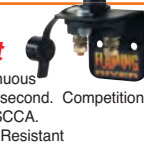

Heavy Duty On/Off Switch w/Rubber Cover for Magneto
QUA360-1220.....\$11.58



Heavy Duty On/Off Switch w/Rubber Cover
QUA360-1210.....\$8.95



Toggle Switch 2 Position On/Off/On w/Rubber Cover
QUA360-1211.....\$11.95



Momentary On/Off Switch w/Rubber Cover
QUA360-1209MILSPEC..\$19.95



On/Off Switch w/Rubber Cover
QUA360-1210MILSPEC..\$19.95



NEW

Bulk Wire - High Temp

Colors	Gauge	Length	Part #	Price
Red	#16	25 ft	QUA360-1500	\$8.92
Red	#16	100 ft	QUA360-1501	\$14.77
Red	#14	25 ft	QUA360-1600	\$10.01
Red	#14	100 ft	QUA360-1502	\$20.39
Red	#12	100 ft	QUA360-1503	\$31.40
Red	#10	100 ft	QUA360-1504	\$64.74
Yellow	#16	25 ft	QUA360-1505	\$8.92
Yellow	#16	100 ft	QUA360-1506	\$14.89
Black	#16	25 ft	QUA360-1510	\$8.92
Black	#16	100 ft	QUA360-1511	\$14.89
Green	#16	25 ft	QUA360-1515	\$8.92
Green	#16	100 ft	QUA360-1516	\$14.89
Orange	#16	25 ft	QUA360-1520	\$8.92
Orange	#16	100 ft	QUA360-1521	\$14.89
White	#16	25 ft	QUA360-1525	\$8.92
White	#16	100 ft	QUA360-1526	\$14.89
Blue	#16	100 ft	QUA360-1531	\$14.89
Brown	#16	100 ft	QUA360-1536	\$14.89
Black/White 2 pair Gray Covered	#16	25 ft	QUA360-1540	\$10.76



Heavy Duty On/Off Switch with Flip Cover
QUA360-1205.....\$14.95



Heavy Duty On/Off Switch with Flip Cover for Magneto
QUA360-1215.....\$18.30



3 Wire Connector

For 2 speed motor like Parker Pumper
QUA360-1265...\$5.95



Master Switch w/Rock Shield

No Mud or Rocks Allowed. Protect that master switch from mud and rocks. The constant beating these switches take can cause them to fail internally.



Total Power - Main Shut-Off. For Total Power with locating pin
BRP9467.....\$28.97

Rebco Style Main Power Shut-Off. For Rebco Style with flats on mounting thread
BRP9468.....\$28.97



Super Battery Disconnect

Red Knob, 500 Amp, 2 Pole
QUA360-1247....\$56.55



Starter Solenoid Four Pole

QUA360-1227....\$11.95



Starter Solenoid Three Pole

QUA360-1228....\$11.95



Oil Pressure Kit w/Light (red) 20 psi sender

Regular.....QUA320-1200.....\$20.60
Jumbo.....QUA320-1205.....\$26.10



Oil Temp Kit w/Light (blue) 275° sender

Regular.....QUA320-1230.....\$24.38
Jumbo.....QUA320-1235.....\$22.95



Water Temp. Kit w/Light (amber) 230° F sender

Regular.....QUA320-1220.....\$25.95
Jumbo.....QUA320-1225.....\$25.95



Fuel Pressure Kit w/Light white 4 psi sender

Regular.....QUA320-1240.....\$22.50
Jumbo.....QUA320-1245.....\$24.59

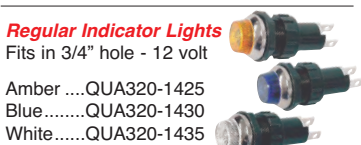

Jumbo Indicator Lights

Fits in 1" hole - 12 volt

Amber...QUA320-1400
Blue.....QUA320-1405
White....QUA320-1410
Red.....QUA320-1415
\$16.00



Indicator Light

Fits in 1/2" hole - 12 volt
QUA360-1260....\$6.95



Oil Pressure Sender

20 psi...QUA320-1260..\$11.88

Fuel Pressure Sender

4 psi...QUA320-1255...\$9.96

Water Temp Sender

230° F...QUA320-1265..\$18.38

Oil Temp Sender

275° F...QUA320-1270..\$15.14



Quick Disconnect Starter Harness

Fits Tilton style starters.....MOR74245..\$50.56
Fits most GM style starters..MOR74250..\$34.64



Push/Pull Battery Disconnect

18" long alum actuator, swing arm link, & necessary bushing & fasteners to mount to switch.
MOR74105.....\$62.71

Battery Disconnect Switches

Limited service (drag race without alt)
20 amp rating.....MOR74100.....\$38.36
Heavy Duty (oval track, RVs, street applications, drag cars with alternators)....MOR74101.....\$46.88



Battery Cable Terminal Kits

2 Battery Ends
MOR74175.....\$19.08
2 Remote End
MOR74170.....\$18.28



Battery Cable Kits

High Grade 2 gauge copper. Ideal for moving battery to rear for better weight distribution.
1.) 20' w/ 4 terminals.....MOR74005.....\$100.53



2.) 20' w/4 term. 8' w/top post term. and 6" 12 gauge leads w/butt connectors, rubber lined clamps, grommets and shrink sleeving.....MOR74055.....\$138.40

Thru-Panel Battery Connector

Fits thru 1-1/4" hole. 1 per package.
MOR74145.....\$15.66



Quick Disconnect Battery Connector

Quick release half turn lock for easy charger hook-ups.
2 per pack.....MOR74155...\$149.31

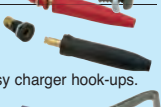

Battery Quick-Connect Plug

Instantly connect your car to charger or auxiliary battery.
MOR74200.....\$60.39

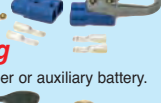

Remote Battery Jumper Terminals

2 per package. Color coded caps.
MOR74140.....\$43.11



Battery Terminal Disconnect Switch

Switch is rated at 100 amps for 12 or 24 DC use.

Battery Terminal Disc Switch
MOR74103.....\$16.17
Bat Terminal Disc Switch, Side Post
MOR74104.....\$17.34



Starter Heat Shield

High temp insulation between two sheets of aluminum.

Small Tilton style starters
MOR74299.....\$34.71



Starter Button

35 amp, waterproof for dash or underhood mounting.
MOR74120....\$12.40



Toggle Switches

1-1/2" handle, momentary..MOR74124..\$19.17
1-1/2" handle, on/off.....MOR74125..\$11.41
11/16" handle, on/of.....MOR74126..\$8.21

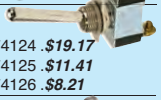

Adj. Momentary Switch

15 amp rating is ideal for operating trans-brakes. Adj collar allows button travel to be preset from .020 to .219" to adjust for reaction time.
MOR74123.....\$33.17



Universal Momentary Switch & Cable

Remote switch and cable for radio, trans brakes, line locks or nitrous. Button is normally open, short throw, mounts in 1/4" hole.
MOR74122....\$46.03

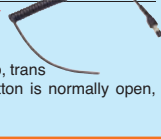

WIRING HARNESS

PAINLESS

12-Circuit Universal Harness GM Keyed Steering Column

It includes GM (column mounted) ignition switch plugs and a GM (column mounted) turn signal switch plug pre-terminated and ready to install. Also has pre-wired plugs for headlights and the dimmer switch.

PAI10101.....\$299.99

18-Circuit Universal Harness GM Keyed Steering Column

It allows you to add accessories to the basic wiring such as power windows, door locks, stereo, etc. This kit includes GM (column mounted) ignition switch plugs and a GM (column mounted) turn signal switch plug pre-terminated and ready to install. Also has pre-wired plugs for headlights and the dimmer switch.

PAI10201.....\$349.99

69-74 GM Muscle Cars

A pre-wired factory style bulk-head connector plugs into to the fuse block through the firewall in the stock location. Easy-to-install, factory original, quick connect terminals are included for the in-dash printed circuit board. Pre-terminated plugs for the ignition and turn signal switches are included. 69-74 Nova, El Camino, Monte Carlo, Apollo, Chevelle, Cutlass, Skylark, Tempest and GTO.

PAI20102...\$731.99

12 Circuit 66-67 Chevy II / Nova Harness

This vehicle specific 12-circuit harness makes easy work of rewiring your Nova. Kit includes three harnesses: Main harness, Tail harness, Dome harness. The following connectors are already installed on the harness: Headlight switch, Headlight connectors, Fuel gauge connector, Dimmer switch, Brake switch, Heater switch, Blower resistor, Wiper switch, Backup switch, Horn, Dash light sockets, Warning light sockets. Includes: Alt pigtail with connector installed, Harness for factory air, 2 door jamb switches, High output all kit, 50 amp Maxi Fuse.

PAI20110...\$768.99

12-Circuit Universal Fuse Block

Use this OEM style pre-wired fuse block to replace your existing fuse block or as a starting point for custom wiring. All you have to do is terminate your circuit wire and attach it to the fuse block.

PAI30001\$154.99

12-Circuit Pro-Street Harness

Looking to operate your circuits through the factory switches and not a switch panel? This Pro-Street harness is for you. Contains all the features of the 12-circuit harness in the Drag Race Wiring Kit but with necessary pigtailed to direct wire the start, ignition, fan, fuel pump, water pump & lighting circuits.

PAI50002....\$503.99

Drag Race Wiring Kit

The 8-rocker switch control center plugs directly into the 12-circuit Pro Street harness making this the easiest and most complete way to wire a race car. Harness circuits include electric water pump, radio, electric fan, fuel pump, brake lights, headlights, tail lights, wipers, turn signals, flashers, horn and coil. The switch panel features heavy duty rocker switches to control start, ignition, fan, fuel pump one, fuel pump two, water pump, lights and one accessory.

PAI50003...\$794.99

5.0L Ford Wiring Harness/86-93

Factory style replacement harness for this popular Ford EFI engine. Harness comes complete with factory connectors, terminals, color coded and plugs directly into the factory ECM. Harness is designed to mount ECM either on the firewall, underneath the dash or kick panel.

PAI60510...\$514.99

4 Switch Fused Panel with all necessary wiring and hardware

Heavy duty LW non-reflective housing designed to mount to a roll bar using std metal hose clamps. Lighted rocker switches are color coded for quick visual reference. All circuits individually fused and easily accessible for quick testing & replacement. Kit comes complete with 18 feet of TXL wire using machine applied, vibration resistant, fully insulated terminals. Panel controls: Start, Ignition and 2 accessories.

PAI50301...\$269.99

6 Switch Fused Panel

Heavy duty LW non-reflective housing designed to mount to a roll bar using std metal hose clamps. Lighted rocker switches are color coded for quick reference. All circuits individually fused and easily accessible for quick testing and replacement. All units come complete with 18 feet of TXL wire using machine applied, vibration resistant, fully insulated terminals. Kit controls: Start, ignition, fuel pump, electric fan/water pump and two accessories.

PAI50302...\$334.99

Fan-Thom Electric Fan Relay

Designed as inexpensive protection for your electric fan. Provides constant voltage, protects from voltage and amperage spikes and keeps fan from feeding back through the system. An absolute necessity if adding an on/off switch to your electric fan circuit.

PAI30101...\$27.99

Fan Relay w/Thermostat

Designed as inexpensive protection for your electric fan. Provides constant voltage, protects from voltage and amperage spikes and keeps fan from back feeding through the system. The Fan-Thom II comes with a threaded thermostat that screws into the engine block or manifold for a professional installation. Thermostat thread size: 3/8"-18 NPT fitting.

(on @ 195° • off @ 185°)..PAI30102...\$54.99
(on @ 185° • off @ 175°)..PAI30103...\$54.99

Universal Fuel Pump Relay

A relay will prevent voltage drops at the pump thus maintaining constant fuel pump pressure, and will prevent fuel pump amperage overloads from damaging the electrical system. It's a good idea to relay your fuel pump for the street and a must when you're racing.

PAI50102.....\$34.99



The First Mate Electrical Repair Kit

BSC80760.....\$39.06



Deutsch Compatible AT Series Connector Kit (224 pc)

BSC80765.....\$106.38



Vinyl Insulated Terminal Kit with Crimper

BSC80756...\$22.83

Terminal Kit w/o Crimper

BSC80757...\$6.75



Dual Wall 3:1 Shrink Tube 6" Length 1/8"-1" (66 pc.)

BSC80751.....\$47.93

Dual Wall 3:1 Shrink Tube 6" Length 1/8"-1" (30 pc.)

BSC80752.....\$21.60

Electric Water Pump Relay

This relay kit provides constant voltage to maximize cooling efficiency and protect the main electrical system from damaging amperage overloads.

PAI50106..\$29.99

High Amp Alternator Shut Down Relay

This new kit, complete with 250 amp solenoid, will effectively handle alternator feedback of the highest amperage alternators. Eliminates engine run-on when the master disconnect is turned off.

PAI50105\$137.99

8-Circuit Race Car Harness

Machine pre-terminated fuse block and relays. Every circuit is protected with a fuse AND a 30-amp relay for maximum reliability. Kit: Start, ignition, electric water pump, electric fan, electric fuel pump #1, electric fuel pump #2, lights, & accessories. Comes w/18' of wire per circuit, terminals, wire ties, fusible link, rubber grommet, and easy to follow instructions. Designed to be used with our PAI50201 & PAI50202 non-fused switch panels.

PAI50001\$423.99



Battery Extender 6, 8, 12 16V/5A

Battery extenders keep your battery at full charge on a continuous basis. Batteries not kept at full charge become sulfated. Compatible with all Lead Acid Batteries: Std (Flooded), AGM, Gel Cell - 6v, 8v, 12v and 16v. Parasitic drain protection. Fully automatic "smart" charging enables energy efficient and safe charging via AutoMeter's advanced software and digital circuitry. The BEX series chargers are fully equipped with sophisticated circuitry that will safely charge and maintain batteries without overcharging. Charging lights will tell you what stage of charge your battery is currently taking. Your battery is ready to go when you need it. Ruggedized and Water Resistant. BEX series battery extenders are purpose built to resist water. AUTOBEX-5000.....\$74.95

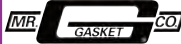

Battery Box Kit - Trunk Mounted - for Up to 12" Long Batteries

Includes a plastic battery case molded from polyethylene, battery hold-down and brackets, 20' of 2 ga. stranded copper battery cable, 4 lugs, a pair of cable ends and related hardware. Case measures 12" x 6 3/4" x 10" high. MRG6279....\$117.95



Battery Boxes

Universal, lightweight steel battery boxes may be welded or bolted to the frame. Boxes are available in two sizes and include hold down hardware.



Full Size, 11-3/4" Wide x 7-1/4" Deep
ALL76100.....\$25.99

Short Style, 9-1/2" Wide x 7-1/4" Deep
ALL76101.....\$23.99



Lightweight Battery Box 11" x 7"

It is designed to be quickly bolted in. Box is 11" wide x 7" deep and includes 3/8" hold down hardware. Zinc plated for corrosion resistance. ALL76102.....\$52.99



Charging Post Bracket

Securely mt charging posts on vehicles where battery is not easily accessible. Pre-drilled holes allow quick mounting to frame or body. Double-D hole design positions posts close together, but provides enough room for charging or jumper cable clamps. Charging posts sold separately. ALL60064.....\$17.99



Drag Race Battery Box

It may be welded or bolted to any chassis. LW box is 7-1/4" wide x 10-1/4" deep, and includes hold down. ALL76106.....\$44.99



S/S Drop-Out Battery Box

Designed for street rods and machines where battery mts under floor. Drop-out feature eases battery service & replacement, and complement underside. Box is 10-1/2" wide, 7" deep & 9-1/2" tall and will accept most std batteries. ALL76105.....\$164.99



Combo Battery & Alt Kill Switch

It is designed to completely shut down the battery and charging system in an emergency situation. Ideal for racing, vehicle storage, marine and RV apps. Prevents battery drain, theft, and reduces the risk of electrical fire. PushOff for emergency shut-down and color-coded to indicate operating position-ON or OFF, with a durable spring-loaded design. Meets IHRA, NHRA & SCCA sanctioning body requirements.



Rated Capacity: Battery - 2000 Amp Surge • 150 Amp Continuous • Alternator - 120 Amp
FLAFR1013.....\$79.92



Economy Battery Disconnect Switch

QUA360-1242....\$13.50



QUA360-1240

Heavy Duty Battery Disconnect Switch

Without AlternatorQUA360-1240 ..\$25.40
With AlternatorQUA360-1245 ..\$26.28



Weatherproof Battery Disconnect Switch

450 amps
QUA360-1240WP..\$34.59



Weatherproof Battery Disconnect Switch w/Alt Terminals

QUA360-1245WP....\$36.53



Sealed Battery Box

Approved by NHRA & IHRA. Holds series 24 battery. Holes for cable and vent not drilled for custom installation. Doesn't include cable. Ideal for relocating a battery to the rear of any race, street or show vehicle with or without a rear firewall. Holds a Series 21, 24, 26, 34, 42, 54, 55, 56, 61, 62, 63, 85, 86 and 96R battery with either top-post or side-post terminals; Outside Dims: 13-1/8" W, 11-1/8" D, 11-1/8" T. Fully approved for racing by NHRA, IHRA & SCCA. Includes all mounting hardware, rubber cable clamps & grommets.



Black....MOR74051...\$69.21

Sealed Battery Box

Jaz Sealed Battery Case is a rotational molded plastic case that is resistant to battery acid. The case measures 10-1/2" long, 13" wide and 9-1/2" tall. Fits group 24 batteries with top or side post terminals.



- Completely sealed with gasket in lid
- Vent tube to carry battery gasses outside of vehicle
- NHRA & IHRA approved 3/8" hold down rods
- Mounting bracket and all hardware included
- Size: 10-1/2" L x 13" W x 9-1/2" H

JAZ700-500-01...\$87.70



Thru Firewall Battery Connector

Black .QUA360-1250 ..\$9.98
Red ...QUA360-1251 ..\$9.98



Battery Jumper Terminals

QUA360-1255...\$26.95



Remote Battery Jumper Terminals

2 per pkg. Color coded caps.
MOR74140.....\$43.11



Battery Terminal Disconnect Switch

Switch is rated at 100 amps for 12 or 24 DC use.



Bat Terminal Disc Switch
MOR74103.....\$16.17

Bat Terminal Disc Switch, Side Post
MOR74104.....\$17.34



Photo by Bob Armbruster



Push/Pull Battery Disconnect

18" long alum actuator, swing arm link, and necessary bushing and fasteners to mount to switch.
MOR74105.....\$62.71



Battery Disconnect Switches

Limited service (drag race without alternator)
20 amp rating.....MOR74100.....\$38.36

Heavy Duty (oval track, RVs, street applications, drag cars with alternators)....MOR74101.....\$46.88

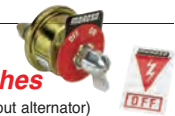

Battery Cable Terminal Kits

2 Battery Ends
MOR74175.....\$19.08

2 Remote End
MOR74170.....\$18.28



Battery Cable Kits

High Grade 2 gauge copper. Ideal for moving battery to rear for better weight distribution.

1.) 20' w/ 4 terminals.....MOR74005.....\$100.53

2.) 20' w/4 term. 8' w/top post term. and 6" 12 gauge leads w/butt connectors, rubber lined clamps, grommets and shrink sleeving.....MOR74055.....\$138.40



Thru-Panel Battery Connector

Fits thru 1-1/4" hole. 1 per package.
MOR74145.....\$15.66



Quick Disconnect Battery Connector

Quick release half turn lock for easy charger hook-ups.
2 per pack....MOR74155...\$149.31



Battery Quick-Connect Plug

Instantly connect your car to charger or auxiliary battery.
MOR74200.....\$60.39



BATTERIES

S680 12 Volt AGM Battery

Good start up output, Over 1000 Amps will start most V8's. Weighs less than 17 lbs. Super compact - Can be mounted virtually anywhere. Includes SAE post terminals and protective metal case for under hood use.
XSPS680\$135.99



S680 12 Volt AGM Battery

Part #.....Price.....Weight.....L x W x H
XSPS680.....\$135.99.....16.2 lbs7.28 l x 3.19 w x 6.67 h.....CA@32°F 300

S975 12 Volt AGM Battery

Weighs only 29 lbs. Thin width fits in between frame rails. Great for race cars and street rods with limited space. Popular drag, circle track, and off road racing application. Includes SAE post terminals and protective metal case for under hood use.
XSPS975\$189.99



S975 12 Volt AGM Battery

Part #.....Price.....Weight.....L x W x H
XSPS975.....\$189.99.....29.1 lbs7.83 l x 5.3 w x 6.67 h.....CA@32°F 500

S1600 16 Volt AGM Battery

Lightest 16V battery! Test results have proven that they outperform other 16 V batteries weighing 10-20 lbs. more. Their cutting-edge lead acid battery tech produces more energy in a smaller space because each cell is compressed before insertion into the case.
XSPS1600 ...\$299.99



S1600 16 Volt AGM Battery

Part #.....Price.....Weight.....L x W x H
XSPS1600.....\$299.99.....30.80 lbs10.28 l x 7.24 w x 6.75 h.....CA@32°F 500

S925 12 Volt AGM Battery

Weighs less than 27 lbs. Low height fits in compact battery trays and under seats. Great for race cars and street rods with limited space. Mounts directly into GM group 34 applications when using part # 527 adapter kit. Includes SAE post terminals and protective metal case for under hood use.
XSPS925\$179.99



S925 12 Volt AGM Battery

Part #.....Price.....Weight.....L x W x H
XSPS925.....\$179.99.....26.83 lbs6.65 l x 7.08 w x 5.07 h.....CA@32°F 550

S1200 12 Volt AGM Battery

Weighs only 36 lbs. Compact design, fits in almost any factory battery location. Great for race cars and street machines with higher amp loads. Enough power to crank the biggest performance engines. Includes SAE post terminals and protective metal case for under hood use.
XSPS1200 ...\$215.99



S1200 12 Volt AGM Battery

Part #.....Price.....Weight.....L x W x H
XSPS1200.....\$215.99.....36.23 lbs7.97 l x 6.73 w x 6.79 h.....CA@32°F 725



S3400 12 Volt AGM Battery

Weighs only 47 lbs. Compact design, fits in almost any factory battery location. Great for race cars and street machines with higher amp loads. Enough power to crank the biggest performance engines. Includes SAE post terminals and protective metal case for under hood use.
XSPS3400 ...\$299.99



S3400 12 Volt AGM Battery

Part #.....Price.....Weight.....L x W x H
XSPS3400.....\$299.99.....47 lbs10.28 l x 6.75 w x 7.24 h.....CA@32°F 1000A

D1600 16 Volt AGM Battery

Strongest 16 volt battery available. AGM battery technology. Longer life. Superior cranking. Fast charge capability. Vibration resistant. Rugged ABS case. Includes SAE post terminals and 3/8" bolts.
XSPD1600 ...\$299.99



D1600 16 Volt AGM Battery

Part #.....Price.....Weight.....L x W x H
XSPD1600.....\$299.99.....46.00 lbs10.24 l x 6.75 w x 7.2 h.....CA@32°F 675

16V AGM Battery Charger

16V AGM compatible. 20A max output. 2 charging modes. LED indicators and ammeter to monitor status. 6' heavy duty cables w/clamps. Built-in cooling fan for reliability. Compact size, only 16 lbs. Constant current/constant voltage.
XSP1004...\$234.99



12V/16V AGM Intelli Charger

12 volt and 16 volt AGM compatible. 25A Max output. 3 charging modes. LED indicators and ammeter to monitor status. 6' heavy duty cables w/clamps. Built-in cooling fan for reliability. Compact size, only 24 lbs. Constant current/constant voltage.
XSP1005...\$334.99



16V High Frequency AGM IntelliCharger, 15A

XS Power manufactures these compact, yet versatile chargers that will get you all charged up. These battery chargers feature a built-in monitoring system, computer analysis, and are rated up to 15 amps. They come available in 12, 14, and 16 V versions.
XSPHF1615.....\$199.99



Advanced AGM Lightweight

Batteries have always presented the same problems of weight, safety, and cost. In racing, aerospace, and advanced technology industries, weight and safety present the two biggest challenges. Braille Battery's solution is developing lighter, more powerful batteries to suit the needs of these markets. Braille Battery's Advanced AGM batteries have allowed for more power, safer design and less overall weight than the batteries they replace, as the performance leader in the 12 volt sealed AGM (lead-acid) marketplace.



Part #	Price	Weight	L x W x H	PCA	Ah	Positive
BRLB106	\$149.99	6.9 lbs.	5.8" x 3.4" x 4.2"	527	10	Left
BRLB129	\$159.99	9.5 lbs.	5.8" x 3.4" x 5.1"	813	12	Left
BRLB14115	\$169.99	11.5 lbs.	5.8" x 3.4" x 5.8"	904	15	Left
BRLB2015	\$199.99	15 lbs.	6.8" x 3.4" x 6.1"	1067	20	Right
BRLB2317	\$199.99	17 lbs.	6.8" x 4" x 6.1"	1191	23	Left
BRLB2317RP	\$199.99	17 lbs.	6.8" x 4" x 6.1"	1191	23	Right
BRLB2618	\$219.99	18.5 lbs.	8.1" x 3.5" x 6.3"	1168	26	Right
BRLB3121	\$229.99	21 lbs.	6.6" x 5.2" x 6.8"	1380	31	Right



Lightweight Carbon Fiber AGM

Patent Pending Carbon Case Design Made for Extreme Temperatures and Vibration. More Reliability and Performance in High Temperatures. Exclusive Appearance and Design. Hand Selected Premium Products for the Highest Performing Advanced AGM Product.



Part #	Price	Weight	L x W x H	PCA	Ah	Positive
BRLB106C	\$274.99	6.9 lbs.	5.8" x 3.4" x 4.2"	527	10	Left
BRLB14115C	\$299.99	11.5 lbs.	5.8" x 3.4" x 5.8"	904	15	Left
BRLB2015C	\$324.99	15 lbs.	6.8" x 3.4" x 6.1"	1067	21	Right
BRLB3121C	\$374.99	21 lbs.	6.6" x 5.2" x 6.8"	1380	31	Right



Long Lasting Endurance Series

Original equipment replacement that have the highest cranking power and the longest run times (Amp/Hr Ratings) in their class. These batteries offer the AGM internal racing technology developed for our Advance AGM and Carbon Fiber batteries.



Part #	Price	Weight	L x W x H	PCA	Ah	Positive
BRLB6034	\$299.99	41 lbs.	10.1" x 6.3" x 7.75"	2132	60	Left
BRLB7548	\$339.99	45 lbs.	10.9" x 6.8" x 7.5"	2390	75	Right
BRLB10049	\$399.99	58 lbs.	13.9" x 6.8" x 7.5"	2856	100	Right



MICRO-LITE LITHIUM

Micro • Lite LW Lithium-ion

Carbon Composite Casings* with CNC Precision Cell Top Design Contain Ultra-Lightweight Lithium-Ion Chemistries Hand Selected and Built by a Braille Factory Technician in the USA. High Current Interconnects, Proprietary Sine-Wave Balancing and High Amp Brass Terminals are just some of the Exotic Technologies for Professionals and Enthusiast that Demand the Best.



Part #	Price	Weight	L x W x H	PCA	Ah	Positive
BRLMLF1T	\$399.99	1 lbs.	7" x 1.3" x 2.3"	150	9	Left
BRLML9C	\$949.99	3.7 lbs.	5.8" x 3.4" x 4.25"	693	36	Left/Right
BRLML14C	\$1249.99	4.5 lbs.	5.75" x 3.4" x 5.8"	827	42	Left
BRLML20C	\$1499.99	6.1 lbs.	6.8" x 3.4" x 6"	1152	48	Right
BRLML30C	\$1999.99	9.3 lbs.	6.6" x 5.2" x 6.88"	1658	84	Right
BRLB128L	\$1999.99	8.8 lbs.	10" x 3.25" x 6.5"	1482	90	Right



SUPER-SIXTEEN LITHIUM

Light & Strong Super 16V Lithium

Braille's exclusive 16 volt Lithium technology offers more starting performance and stable voltages per pound than any option available on the market. Sealed Safe Design in popular sizes that are mountable in any position.



Part #	Price	Weight	L x W x H	PCA	Ah	Positive
BRLB168L	\$1899.99	8 lbs.	10" x 3.25" x 6"	1925	60	Left
BRLB169L	\$899.99	8.9 lbs.	10" x 3.25" x 6"	950	75	Left



INTENSITY LITHIUM

Race Lithium-ion Intensity Carbon

Race Winning Lithium Technology Designed for the Enthusiast and the Professional. Tremendous Weight Savings, Original Equipment Direct Replacement Sizing and Superior Starting. Excellent Off-Season Storage Performance. Brass Terminals, and High Amp Design. RoHS, Environmentally Friendly and DOT Approved. Custom Design Available.



Part #	Price	Weight	L x W x H	PCA	Ah	Positive
BRLI34CE	\$1549.99	9.7 lbs.	10.4" x 6.3" x 5.5"	1320	75	Left/Right
BRLI34CX	\$1599.99	10.2 lbs.	10.4" x 6.8" x 7.7"	1320	75	Left/Right
BRLI34CS	\$2499.99	17.5 lbs.	10.4" x 6.8" x 7.7"	2500	145	Left/Right
BRLI48CE	\$1599.99	10 lbs.	11" x 6.8" x 5.5"	1340	75	Right
BRLI48CX	\$1649.99	10.5 lbs.	11" x 6.8" x 7.7"	1340	75	Right
BRLI48CS	\$2479.99	18 lbs.	11" x 6.8" x 7.7"	2520	150	Right
BRLI49CE	\$1999.99	13.9 lbs.	13.9" x 6.8" x 5.5"	2020	114	Right
BRLI49CX	\$2099.99	14.4 lbs.	13.9" x 6.8" x 7.7"	2020	114	Right
BRLI49CS	\$3499.99	21.5 lbs.	13.9" x 6.8" x 7.7"	3150	189	Right



Electronic Battery Charger

Braille Battery's 2 amp trickle battery chargers are a safe, reliable way to extend the life of your Braille battery or any type of 12 V battery in your shop or home.

Features include:

- 12 V charger • 2 amp hour • 3-LED indicator
- Reverse polarity protection
- Race and alligator quick-connects, perfect for race cars, street cars, and motorcycles.

BRL1232\$99.99



Super 16TM Lithium B169L Battery

Lighter. Stronger. Faster. Easy Install: Direct Group 34 Drop In Replacement. **Lighter:** 40 Pounds Lighter than Equal Capacity. **Safer:** Sealed Safe Design. **Efficient:** Stable Voltage Output. **Greener:** Modular Design For Service or Repair. **Reliable:** Longer Cycle Life, Better shelf Life.

BRLB168LC.....\$1999.99

Voltage Class: 16 volts
 Full Charge Range: 17.4-17.6 volts
 Pulse Cranking Amps @ 80F: 950
 Nominal Capacity (C/5 rate): 25 AH
 Lead-Acid Equivalent Cap: 75 Lithium AH (LAH)
 Life Cycle @ 80% DOD: Up to 1000 cycles
 Life Cycle @ 10% DOD: Up to 5000 cycles



Battery charger: Braille 1632L - "Super 16" 2 amp lithium
 Rapid Recharge: Braille 16310L - "Super 16" 10 amp lithium
 Max Charge Voltage @70F: Up to 20.5 volts • Recommended Charge Voltage: 18.25 Volts

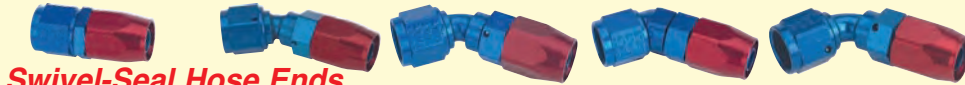

Swivel-Seal Hose Ends

size	straight	30°	45°	45° Low Profile	60°
-6	EAR800106...\$8.14	EAR803106...\$23.50	EAR804606...\$21.56	EAR804506...\$24.04	EAR806106...\$21.56
-8	EAR800108...\$10.19	EAR803108...\$28.01	EAR804608...\$26.58	EAR804508...\$28.74	EAR806108...\$26.58
-10	EAR800110...\$13.77	EAR803110...\$31.70	EAR804610...\$29.62	EAR804510...\$35.79	EAR806110...\$29.62
-12	EAR800112...\$19.00	EAR803112...\$40.03	EAR804612...\$36.31	EAR804512...\$44.05	EAR806112...\$36.31
-16	EAR800116...\$28.62	EAR803116...\$48.46	EAR804616...\$43.59	EAR804516...\$64.63	EAR806116...\$43.59



size	90°	90° Low Profile	120°	150°	180°
-6	EAR809106...\$20.81	EAR809006...\$22.34	EAR812006...\$24.93	EAR815006...\$25.15	EAR818006...\$25.11
-8	EAR809108...\$26.81	EAR809008...\$28.74	EAR812008...\$29.06	EAR815008...\$29.10	EAR818008...\$28.43
-10	EAR809110...\$30.21	EAR809010...\$34.79	EAR812010...\$33.55	EAR815010...\$31.60	EAR818010...\$32.65
-12	EAR809112...\$36.31	EAR809012...\$41.29	EAR812012...\$40.24	EAR815012...\$40.28	EAR818012...\$38.98
-16	EAR809116...\$44.57	EAR809016...\$61.43	EAR812016...\$59.02	EAR815016...\$58.73	EAR818016...\$61.12

Swivel-Seal hose ends have a unique nipple and cutter design, a design aerospace proven for over 45 years. Tightening the ferrule pulls the hose into a sharp cutter providing an unsurpassed seal. Most common uses for the Swivel-Seal are fuel lines and remote oil filter or dry sump lines. For use with Perform-O-Flex or Pro-Lite 350 hose only.

Use with Perform-O-Flex or Pro-Lite 350



Use with Perform-O-Flex or Pro-Lite 350

Auto-Fit hose ends provide the reliability of the Swivel-Fit, but are easier to assemble and are less expensive. Barbs on both the inside and outside of the fitting grip the hose as you tighten to ensure a positive seal. Common uses for Auto-Fit hose ends are fuel and oil lines, gauges, and water lines. They should only be used with the Perform-O-Flex hose in this catalog.



Auto-Fit Hose Ends

size	straight	45°	90°	120°	150°	180°
-4	EAR300104...\$8.55	EAR304604...\$19.42	EAR309104...\$19.42	EAR312004...\$24.25	EAR315004...\$24.25	EAR318004...\$23.91
-6	EAR300106...\$7.33	EAR304606...\$17.88	EAR309106...\$17.88	EAR312006...\$17.88	EAR315006...\$17.88	EAR318006...\$17.88
-8	EAR300108...\$9.44	EAR304608...\$19.99	EAR309108...\$19.99	EAR312008...\$19.99	EAR315008...\$19.99	EAR318008...\$19.99
-10	EAR300110...\$11.56	EAR304610...\$22.10	EAR309110...\$22.10	EAR312010...\$22.10	EAR315010...\$22.10	EAR318010...\$22.10
-12	EAR300112...\$16.83	EAR304612...\$26.31	EAR309112...\$26.31	EAR312012...\$26.31	EAR315012...\$26.31	EAR318012...\$26.31
-16	EAR300116...\$24.22	EAR304616...\$35.81	EAR309116...\$35.82	EAR312016...\$35.81	EAR315016...\$35.81	EAR318016...\$35.81
-20	EAR300120...\$56.44	EAR304620...\$84.34	EAR309120...\$84.35	EAR312020...\$84.34	EAR315020...\$84.34	EAR318020...\$84.34
-24	EAR300124...\$101.95	EAR304624...\$122.95	EAR309124...\$122.95	EAR312024...\$122.95	EAR315024...\$122.95	EAR318024...\$122.95

Auto-Mate hose ends are still the best barbed aluminum nipple hose ends. Used with the Econo-O-Fit hose clamp cover, they provide a sure seal for most applications of fuel and oil lines, heater and water hoses, or crankcase vents...



Auto-Mate Hose Ends

size	straight	45°	90°	120°	180°
-4	EAR700104...\$8.38	EAR704604...\$20.26	EAR709104...\$17.36	EAR712004...\$19.41	EAR718004...\$19.41
-6	EAR700106...\$8.13	EAR704606...\$20.26	EAR709106...\$17.36	EAR712006...\$19.41	EAR718006...\$19.41
-8	EAR700108...\$8.03	EAR704608...\$21.11	EAR709108...\$19.41	EAR712008...\$20.43	EAR718008...\$21.46
-10	EAR700110...\$11.50	EAR704610...\$24.53	EAR709110...\$23.50	EAR712010...\$23.50	EAR718010...\$30.73
-12	EAR700112...\$15.94	EAR704612...\$25.55	EAR709112...\$27.60	EAR712012...\$27.60	EAR718012...\$34.06
-16	EAR700116...\$26.21	EAR704616...\$33.74	EAR709116...\$33.74	EAR712016...\$33.74	EAR718016...\$43.96



Swivel-Seal & Auto-Fit Replacement Sockets

Hose size	Price
4	EAR898043...\$4.17
6	EAR898063...\$3.11
8	EAR898083...\$4.17
10	EAR898103...\$5.22
12	EAR898123...\$5.22
16	EAR898163...\$10.50
20	EAR898203...\$17.88
24	EAR898243...\$38.67

Male Pipe Threads

Thread Size	Hose Size	straight	Thread Size	Hose Size	45°	Thread Size	Hose Size	90°
1/8	6	EAR820162...\$12.82	1/8	6	EAR824562...\$31.85	1/8	6	EAR829062...\$31.85
1/4	6	EAR820106...\$13.37	1/4	6	EAR824506...\$31.85	1/4	6	EAR829006...\$29.60
3/8	6	EAR820166...\$15.79	3/8	6	EAR824566...\$31.85	3/8	6	EAR829066...\$31.30
3/8	8	EAR820108...\$16.19	3/8	8	EAR824508...\$38.57	3/8	8	EAR829008...\$34.09
1/2	8	EAR820188...\$20.65	1/2	8	EAR824588...\$38.59	1/2	8	EAR829088...\$35.21
3/8	10	EAR820111...\$20.65	3/8	10	EAR824511...\$42.47	3/8	10	EAR829011...\$37.45
1/2	10	EAR820110...\$20.65	1/2	10	EAR824510...\$41.36	1/2	10	EAR829010...\$37.45
1/2	12	EAR820113...\$31.85	1/2	12	EAR824513...\$50.31	1/2	12	EAR829013...\$50.65
3/4	12	EAR820112...\$26.32	3/4	12	EAR824512...\$50.31	3/4	12	EAR829012...\$50.65

Male AN Threads

Male Thread Size (AN)	Hose Size	Straight Flare/O'Ring	45° O'Ring Only	90° O'Ring Only
7/16-20 (AN-4)	6	-----	EAR844564...\$35.79	EAR849064...\$35.05
1/2-20 (AN-5)	6	-----	EAR844565...\$35.79	EAR849065...\$35.05
9/16-18 (AN-6)	6	EAR840106...\$12.17	EAR844506...\$35.05	EAR849006...\$35.05
3/4-16 (AN-8)	6	-----	EAR844568...\$38.57	EAR849068...\$35.05
9/16-18 (AN-6)	8	-----	EAR844586...\$35.05	EAR849086...\$39.50
3/4-16 (AN-8)	8	EAR840108...\$15.62	EAR844508...\$38.57	EAR849008...\$39.50
7/8-14 (AN-10)	8	-----	EAR844581...\$38.57	EAR849081...\$39.50
3/4-16 (AN-8)	10	-----	EAR844509...\$42.23	EAR849009...\$43.18
7/8-14 (AN-10)	10	EAR840110...\$16.37	EAR844510...\$42.23	EAR849010...\$43.18
1/16-12 (AN-12)	10	-----	EAR844511...\$52.00	EAR849011...\$52.00
7/8-14 (AN-10)	12	-----	EAR844513...\$52.00	EAR849013...\$52.00
1/16-12 (AN-12)	12	EAR840112...\$22.91	EAR844512...\$52.00	EAR849012...\$52.00

Cushioned Tubing Hose Clamps

Alum Finish	Fits Tube or Hose O.D.	Pkg. Qty	Price
EAR171003	3/16" ----	10	\$13.98
EAR171004	1/4" ----	10	\$13.98
EAR171005	5/16" ----	10	\$13.98
EAR171006	3/8" ----	10	\$13.98
EAR171008	1/2" (-6)	5	\$10.19
EAR171010	5/8" (-8)	5	\$10.19
EAR171012	3/4" (-10)	5	\$10.19
EAR171016	1" (-12)	5	\$10.19

Perform-O-Flex SS Braided Hose

size	3'	6'	10'	20'	33'
-4	EAR403004..\$25.26	EAR406004..\$46.37	EAR410004..\$74.85	EAR420004..\$147.95	EAR433004..\$239.95
-6	EAR403006..\$28.42	EAR406006..\$52.68	EAR410006..\$86.43	EAR420006..\$168.95	EAR433006..\$276.95
-8	EAR403008..\$31.60	EAR406008..\$60.07	EAR410008..\$98.06	EAR420008..\$193.95	EAR433008..\$316.95
-10	EAR403010..\$34.76	EAR406010..\$66.40	EAR410010..\$109.95	EAR420010..\$213.95	EAR433010..\$350.95
-12	EAR403012..\$37.92	EAR406012..\$72.73	EAR410012..\$119.95	EAR420012..\$234.95	EAR433012..\$384.95
-16	EAR403016..\$48.47	EAR406016..\$93.82	EAR410016..\$155.95	EAR420016..\$306.95	EAR433016..\$502.95
-20	EAR403020..\$66.39	EAR406020..\$130.95	EAR410020..\$213.95	EAR420020..\$422.95	
-24	EAR403024..\$81.88	EAR406024..\$153.95	EAR410024..\$255.95	EAR420024..\$511.95	



Flame Guard

Non-asbestos insulating sleeve.
 3/8 ID EAR730006...\$5.21
 1/2 ID EAR730008...\$6.28
 3/4 ID EAR730010...\$8.38
 1 ID EAR730012...\$9.44
 1 1/4 ID EAR730014...\$10.50
 1 1/2 ID EAR730016...\$11.56
 All prices per foot.

Pro-Lite 350 Braided Hose

size	3'	6'	10'	20'	33'
-4	EAR350304..\$25.26	EAR350604..\$47.42	EAR351004..\$76.94	EAR352004..\$151.95	EAR353304..\$245.95
-6	EAR350306..\$28.43	EAR350606..\$53.74	EAR351006..\$87.50	EAR352006..\$170.95	EAR353306..\$280.95
-8	EAR350308..\$31.60	EAR350608..\$60.07	EAR351008..\$98.04	EAR352008..\$193.95	EAR353308..\$315.95
-10	EAR350310..\$34.76	EAR350610..\$66.40	EAR351010..\$109.95	EAR352010..\$215.95	EAR353310..\$350.95
-12	EAR350312..\$37.92	EAR350612..\$72.73	EAR351012..\$119.95	EAR352012..\$235.95	EAR353312..\$384.95
-16	EAR350316..\$47.42	EAR350616..\$91.73	EAR351016..\$151.95	EAR352016..\$298.95	EAR353316..\$489.95
-20	EAR350320..\$66.40	EAR350620..\$130.95	EAR351020..\$215.95	EAR352020..\$425.95	EAR353320..\$698.95



Flame Guard

Non-asbestos insulating sleeve.
 3/8 ID EAR570006...\$5.22
 1/2 ID EAR570008...\$6.61
 3/4 ID EAR570010...\$8.45
 1 ID EAR570012...\$9.48
 1 1/4 ID EAR570014...\$10.50
 1 1/2 ID EAR570016...\$11.56
 All prices per foot.

A high quality synthetic rubber reinforced by a full coverage braided fabric sheath. Rated at 250psi and 250° F for continuous service. Suitable for fuel, oil or water. Use only with Super Stock hose ends.

Super Stock Hose - Black

Bulk (Sold by Foot)	10'	20'	33'
EAR780004	N/A	N/A	N/A
EAR780006	EAR781006..\$43.19	EAR782006...\$83.29	EAR783306..\$134.95
EAR780008	EAR781008..\$50.58	EAR782008...\$96.98	EAR783308..\$157.95
EAR780010	EAR781010..\$61.12	EAR782010...\$119.95	N/A
EAR780012	N/A	N/A	N/A

Super Stock Hose - Blue

Bulk (Sold by Foot)	10'	20'	33'
EAR790004	N/A	N/A	N/A
EAR790006	EAR791006..\$43.19	EAR792006...\$83.28	EAR793306..\$134.95
EAR790008	EAR791008..\$53.74	EAR792008...\$104.95	EAR793308...\$169.95
EAR790010	EAR791010..\$64.30	EAR792010...\$134.30	N/A
EAR790012	N/A	N/A	N/A

Inner Support Spring

#...4' Length'		
6...	EAR773406..\$11.39	12...EAR773412..\$11.39
8...	EAR773408..\$11.39	16...EAR773416..\$11.39
10...	EAR773410..\$11.39	

LS Steam Vent Adapters

Replace the rigid hard lines with these adjustable outlet, O-ring seal adapters that converts to -3 or -4 AN plumbing. Earl's Steam tube adapters are the most adjustable and lowest profile available.

-4 Single Out (2)	EARLS9804	\$38.98
-4 Dual Out (2)	EARLS9805	\$49.53
-4 Single (1) & -4 Dual Out (1)	EARLS9806	\$42.14
-3 Single Out (2)	EARLS9807	\$38.98
-3 Dual Out (2)	EARLS9808	\$49.53
-3 Single (1) & -3 Dual Out (1)	EARLS9809	\$42.14

Inner Support Spring for Super Stock Hose

The inner support spring is to be used with Super Stock Hose to prevent collapse when in suction service or when very bend must be made.

Hose #...4' Length'
 10.....EAR770410...\$11.39
 12.....EAR770412...\$11.39

ONLY works with Super Stock!

While designed for street and marine applications, Super Stock hose ends have found favor with racers because of their reliability and ease of use. Simply push the sleeve onto the hose, and push onto the barbed fitting. For use as fuel and oil lines, remote filter or cooler. Only for use with Super Stock hose. Not for use with any stainless steel braided line.

Super Stock Hose Ends

size	straight	45°	90°	120°	180°	Male Pipe Thread (NPT)
-4	EAR700145..\$5.38	EAR704645..\$17.36	EAR709145..\$17.36	EAR712045..\$17.36	EAR718045..\$20.05	EAR720142..\$8.14 (1/8)
-6	EAR700167..\$5.38	EAR704667..\$17.36	EAR709167..\$17.36	EAR712067..\$17.36	EAR718067..\$21.25	EAR720164..\$11.39 (1/4)
-8	EAR700109..\$5.39	EAR704609..\$20.43	EAR709109..\$19.41	EAR712009..\$23.50	EAR718009..\$21.46	EAR720186..\$11.39 (3/8)
-10	EAR700111..\$7.58	EAR704611..\$24.53	EAR709111..\$23.50	EAR712011..\$23.50	EAR718011..\$30.07	EAR720111..\$14.29 (1/2)
-12	EAR700113..\$13.34	EAR704613..\$28.62	EAR709113..\$27.60	EAR712013..\$27.60	EAR718013..\$34.19	EAR720113..\$15.31 (3/4)



DO NOT Use with Perform-O-Flex or Pro-Lite 350

Speed-Seal Hose Ends

size	Aluminum	Steel	Stainless
-3	EAR600133...\$11.81	EAR600103..\$8.14	EAR609193..\$33.52
-4	EAR600134...\$13.21	EAR600104..\$9.17	EAR609194...\$39.14

Low Profile 45°

size	Aluminum	Steel	Stainless
-3	EAR604533...\$36.64	EAR604503..\$24.53	EAR604593..\$49.82
-4	EAR604534...\$36.88	EAR604504...\$25.55	EAR604594...\$50.02

Non Adjustable Tube 45°

size	Aluminum	Steel	Stainless
-3	EAR604633...\$24.00	EAR604603..\$12.22	EAR604693..\$33.52
-4	EAR604634...\$25.35	EAR604604...\$13.24	EAR604694...\$36.51



Speed-Flex SS Braided / Teflon Hose

size	10'	20'
-3	EAR610003...\$35.81	EAR620003...\$68.51
-4	EAR610004...\$45.30	EAR620004...\$86.43

We recommend -3 lines for brakes because they produce higher pressure with little fluid displacement. Clutch systems on the other hand require less pressure, but more displacement of fluid, so we recommend -4 lines for them. Use only with Speed-Seal hose ends.



Non Adjustable Low Profile 90°

size	Steel
-3	EAR608903...\$19.91
-4	EAR608904...\$22.97

Adjustable Low Profile 90°

size	Steel	Stainless
-3	EAR609103...\$14.29	EAR609193...\$33.52
-4	EAR609104...\$14.80	EAR609194...\$39.14



Power Steering Hose

size	6'	10'	20'
-6	EAR130606...\$53.65	EAR131006...\$82.17	EAR132006...\$156.95



Power Steering Hose Ends

size	straight	45°	90°
-6	EAR130106..\$9.62	EAR134606..\$20.43	EAR139106...\$19.97

Pipe Thread to AN Adapters

Pipe Thread to AN Adapters Straight

size	NPT	aluminum straight	steel straight
-3	1/8	EAR981603.....\$3.12	EAR961603.....\$2.96
-3	1/4	EAR981643.....\$5.23	
-4	1/8	EAR981604.....\$3.19	EAR961604.....\$2.14
-4	1/4	EAR981644.....\$4.18	EAR961644.....\$3.96
-4	3/8	EAR981646.....\$5.23	EAR961646.....\$5.97
-6	1/8	EAR981662.....\$4.18	
-6	1/4	EAR981606.....\$4.70	
-6	3/8	EAR981666.....\$4.69	
-8	1/2	EAR981668.....\$6.13	
-8	1/4	EAR981607.....\$5.18	
-8	3/8	EAR981608.....\$4.39	
-8	1/2	EAR981688.....\$6.12	
-10	3/8	EAR981611.....\$6.22	
-10	1/2	EAR981610.....\$6.22	
-10	3/4	EAR981609.....\$10.25	
-12	1/2	EAR981613.....\$10.77	
-12	3/4	EAR981612.....\$10.77	
-16	3/4	EAR981615.....\$18.60	
-16	1	EAR981616.....\$18.86	
-20	1 1/4	EAR981620.....\$27.69	



Pipe Thread to AN Adapters - 45°

size	NPT	aluminum 45°	steel 45°
-3	1/8	EAR982303.....\$8.75	EAR962303.....\$8.95
-4	1/8	EAR982304.....\$8.73	EAR962304.....\$5.14
-4	1/4	EAR982344.....\$9.99	
-6	1/8	EAR982362.....\$10.68	
-6	1/4	EAR982306.....\$8.75	
-6	3/8	EAR982366.....\$11.95	
-6	1/2	EAR982368.....\$18.73	
-8	1/4	EAR982307.....\$14.80	
-8	3/8	EAR982308.....\$10.34	
-8	1/2	EAR982388.....\$17.27	
-10	3/8	EAR982311.....\$17.00	
-10	1/2	EAR982310.....\$17.27	
-10	3/4	EAR982309.....\$24.00	
-12	1/2	EAR982313.....\$23.64	
-12	3/4	EAR982312.....\$23.50	
-16	1	EAR982316.....\$34.04	



Pipe Thread to AN Adapters - 90°

size	NPT	aluminum 90°	steel 90°
-3	1/8	EAR982203.....\$8.24	EAR962203.....\$7.74
-4	1/8	EAR982204.....\$8.36	EAR962204.....\$5.12
-4	1/4	EAR982244.....\$8.80	
-6	1/8	EAR982262.....\$10.22	
-6	1/4	EAR982206.....\$8.36	
-6	3/8	EAR982266.....\$12.08	
-6	1/2	EAR982268.....\$18.57	
-8	1/4	EAR982207.....\$13.71	
-8	3/8	EAR982208.....\$10.59	
-8	1/2	EAR982288.....\$18.57	
-10	3/8	EAR982211.....\$18.12	
-10	1/2	EAR982210.....\$18.41	
-10	3/4	EAR982209.....\$22.44	
-12	1/2	EAR982213.....\$23.46	
-12	3/4	EAR982212.....\$24.00	
-16	3/4	EAR982215.....\$37.46	
-16	1	EAR982216.....\$37.46	



Tee-Pipe Thread on Side

A	B	C	aluminum	steel
-3	-3	1/8	EAR982503...\$10.34	EAR962503...\$8.17
-4	-4	1/8	EAR982504...\$10.39	
-6	-6	1/4	EAR982506...\$11.67	
-8	-8	3/8	EAR982508...\$17.00	
-10	-10	1/2	EAR982510...\$19.46	
-12	-12	3/4	EAR982512...\$31.61	

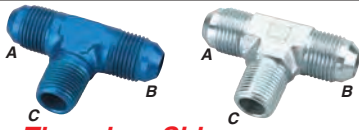

Tee-Pipe Thread on Run

A	B	C	aluminum	steel
1/8	-3	-3	EAR982603...\$10.51	EAR962603...\$7.34
1/8	-4	-4	EAR982604...\$10.13	
1/4	-6	-6	EAR982606...\$11.34	
3/8	-8	-8	EAR982608...\$17.00	
1/2	-10	-10	EAR982610...\$19.43	
3/4	-12	-12	EAR982612...\$32.80	
1	-12	-12	EAR982616...\$52.04	

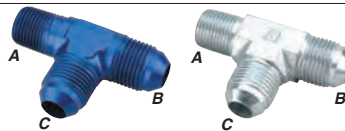

Pipe Thread to Pipe Thread Adapters



NPT to NPT Adapters

size	Male	Female	Price
1/8	EAR991101...\$4.18	EAR991001...\$5.30	
1/4	EAR991102...\$5.23	EAR991002...\$7.52	
3/8	EAR991103...\$8.39	EAR991003...\$8.72	
1/2	EAR991104...\$9.45	EAR991004...\$10.59	
3/4	EAR991106...\$11.57	EAR991006...\$16.53	

45° Elbow

Internal/External Pipe Thread

A	B	Part #	Price
1/8	1/8	EAR991501...\$9.45	
1/4	1/4	EAR991502...\$11.57	
3/8	3/8	EAR991503...\$13.67	



90° Elbow

Internal/External Pipe Thread

A	B	Part #	Price
1/8	1/8	EAR991401...\$7.34	
1/4	1/4	EAR991402...\$12.62	
3/8	3/8	EAR991403...\$15.78	



90° Elbow

Internal Pipe Thread

A	B	Part #	Price
1/8	1/8	EAR991601...\$10.59	
1/4	1/4	EAR991602...\$11.70	
3/8	3/8	EAR991603...\$14.90	

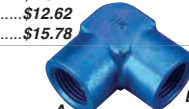

NPT Female Tee

1/8	EAR991701...\$10.51	
1/4	EAR991702...\$11.57	
3/8	EAR991703...\$15.78	



NPT Reducer Bushing

Female	Male	Part #	Price
1/8	1/4	EAR991201...\$5.07	
1/4	3/8	EAR991202...\$6.72	
1/8	3/8	EAR991203...\$6.16	
3/8	1/2	EAR991204...\$6.57	
1/4	1/2	EAR991205...\$7.88	
1/8	1/2	EAR991206...\$8.73	
1/2	3/4	EAR991207...\$9.65	
3/8	3/4	EAR991208...\$9.65	
1/4	3/4	EAR991209...\$11.65	
3/4	1	EAR991210...\$15.31	
1/2	1	EAR991211...\$15.08	
3/8	1	EAR991212...\$15.22	
3/4	1 1/4	EAR991213...\$25.27	



Metric Thread to an Adapter

Part #	Ftg Size	Thread	Price
EAR9919BFB	-4	10 mm x 1	\$8.59
EAR9919BFC	-4	10 mm x 1.25	\$8.59
EAR9919BFD	-4	10 mm x 1.5	\$8.59
EAR9919BFE	-4	12 mm x 1	\$9.00
EAR9919BFF	-4	12 mm x 1.5	\$8.59
EAR9919BFH	-4	14 mm x 1.5	\$8.59
EAR9919DFC	-6	10 mm x 1.25	\$8.67
EAR9919DFD	-6	10 mm x 1.5	\$8.67
EAR9919DFG	-6	12 mm x 1.5	\$8.67
EAR9919DFH	-6	18 mm x 1.5	\$8.67
EAR9919DFJ	-6	14 mm x 1.5	\$8.67
EAR9919DFK	-6	16 mm x 1.5	\$8.67
EAR9919DFL	-6	18 mm x 1.5	\$8.67
EAR9919DFM	-6	20 mm x 1.5	\$8.67
EAR9919DFN	-6	22 mm x 1.5	\$8.67
EAR9919DFP	-6	24 mm x 1.5	\$8.67
EAR9919DFQ	-6	26 mm x 1.5	\$8.67
EAR9919DFR	-6	28 mm x 1.5	\$8.67
EAR9919DFJ	-6	16 mm x 1.5	\$8.67
EAR9919DFK	-6	18 mm x 1.5	\$8.67
EAR9919DFL	-6	20 mm x 1.5	\$8.67
EAR9919DFM	-6	22 mm x 1.5	\$8.67
EAR9919DFN	-6	24 mm x 1.5	\$8.67
EAR9919DFP	-6	26 mm x 1.5	\$8.67
EAR9919DFQ	-6	28 mm x 1.5	\$8.67
EAR9919DFR	-6	30 mm x 1.5	\$8.67
EAR9919DFJ	-6	16 mm x 1.5	\$10.81
EAR9919DFK	-6	18 mm x 1.5	\$11.90
EAR9919DFL	-6	20 mm x 1.5	\$11.90
EAR9919DFM	-6	22 mm x 1.5	\$11.90
EAR9919DFN	-6	24 mm x 1.5	\$11.90
EAR9919DFP	-6	26 mm x 1.5	\$14.08
EAR9919DFQ	-6	28 mm x 1.5	\$17.65
EAR9919DFR	-6	30 mm x 1.5	\$17.65
EAR9919DFG	-6	18 mm x 1.5	\$17.65
EAR9919DFH	-6	20 mm x 1.5	\$24.15
EAR9919DFI	-6	22 mm x 1.5	\$24.15
EAR9919DFJ	-6	24 mm x 1.5	\$24.15
EAR9919DFK	-6	26 mm x 1.5	\$24.15
EAR9919DFL	-6	28 mm x 1.5	\$24.15
EAR9919DFM	-6	30 mm x 1.5	\$24.15

Special Purpose Adapters

size	45° Alum	90° Alum	Price
-3	EAR924103...\$21.60	EAR921103...\$21.05	
-4	EAR924104...\$15.27	EAR921104...\$14.73	
-6	EAR924106...\$18.41	EAR921106...\$14.73	
-8	EAR924108...\$23.05	EAR921108...\$21.05	
-10	EAR924110...\$29.65	EAR921110...\$27.38	
-12	EAR924112...\$40.12	EAR921112...\$34.77	
-16		EAR921116...\$47.53	
Steel		90° Steel	
-3		EAR966303...\$6.95	
-4		EAR966304...\$6.95	

AN Port Adapter

("O" Ring Seal)
(Port End contoured for max. flow)



A	B	Part #	Price
-6	(AN 4) 7/16-20	EAR985064...\$8.39	
-6	(AN 5) 1/2-20	EAR985065...\$9.49	
-6	(AN 6) 9/16-18	EAR985006...\$8.39	
-6	(AN 8) 3/4-16	EAR985068...\$11.83	
-8	(AN 6) 9/16-18	EAR985086...\$12.30	
-8	(AN 8) 3/4-16	EAR985008...\$10.51	
-8	(AN 10) 7/8-14	EAR985081...\$13.67	
-10	(AN 8) 3/4-16	EAR985009...\$13.20	
-10	(AN 10) 7/8-14	EAR985010...\$13.20	
-10	(AN 12) 1 1/16-12	EAR985011...\$17.89	
-12	(AN 10) 7/8-14	EAR985013...\$17.89	
-12	(AN 12) 1 1/16-12	EAR985012...\$17.89	
-16	(AN 16) 1 1/16-12	EAR985015...\$23.16	
-16	(AN 16) 1 5/16-12	EAR985016...\$23.16	

AN Tee

Female Swivel on Side

A	B	C	Part #	Price
-3	-3	-3	EAR925103...\$34.81	
-4	-4	-4	EAR925104...\$16.87	
-6	-6	-6	EAR925106...\$20.00	
-8	-8	-8	EAR925108...\$30.52	
-10	-10	-10	EAR925110...\$35.76	
-12	-12	-12	EAR925112...\$41.23	



AN Tee

Female Swivel on Run

A	B	C	Part #	Price
-3	-3	-3	EAR926103...\$34.66	
-4	-4	-4	EAR926104...\$18.50	
-6	-6	-6	EAR926106...\$20.00	
-8	-8	-8	EAR926108...\$30.60	
-10	-10	-10	EAR926110...\$34.81	
-12	-12	-12	EAR926112...\$45.13	



45° Female

AN Swivel to Female AN Swivel - Tube

A	B	Part #	Price
-3	-3	EAR939203...\$15.06	
-4	-4	EAR939204...\$14.50	
-6	-6	EAR939206...\$14.50	
-8	-8	EAR939208...\$17.87	
-10	-10	EAR939210...\$22.35	
-12	-12	EAR939212...\$25.12	
-16	-16	EAR939216...\$32.92	



90° Female

AN Swivel to Female AN Swivel - Tube

A	B	Part #	Price
-3	-3	EAR935103...\$15.78	
-4	-4	EAR935104...\$15.06	
-6	-6	EAR935106...\$14.50	
-8	-8	EAR935108...\$17.87	
-10	-10	EAR935110...\$22.35	
-12	-12	EAR935112...\$25.12	
-16	-16	EAR935116...\$32.92	





Black Hard Anodized Fittings are on PGS 49-51!

90° Female

AN to Male Swivel NPT (or Metric)

A	B	Part #	Price
-3	1/8	EAR923103	...\$35.38
-4	1/8	EAR923104	...\$24.23
-4	1/4	EAR923144	...\$24.23
-6	1/4	EAR923106	...\$23.46
-6	1/8	EAR923162	...\$23.46
-6	3/8	EAR923166	...\$23.46
-8	1/4	EAR923107	...\$26.98
-8	3/8	EAR923108	...\$26.98
-8	1/2	EAR923188	...\$30.60
-10	1/2	EAR923110	...\$40.11
-10	3/8	EAR923111	...\$40.11
-12	1/2	EAR923113	...\$48.42
-12	3/4	EAR923112	...\$48.42
-6	12mm x 1.25	EAR923191	...\$23.46
-6	12mm x 1.5	EAR923192	...\$23.46

Straight

AN Swivel to Male NPT

A	B	Part #	Price
-3	1/8	EAR916103	...\$10.95
-4	1/8	EAR916104	...\$8.80
-4	1/4	EAR916144	...\$8.33
-6	1/4	EAR916106	...\$8.80
-6	1/8	EAR916162	...\$10.56
-6	3/8	EAR916166	...\$11.32
-8	1/4	EAR916107	...\$11.16
-8	3/8	EAR916108	...\$10.59
-8	1/2	EAR916188	...\$14.26
-10	1/2	EAR916110	...\$13.91
-10	3/8	EAR916111	...\$13.29
-12	3/4	EAR916112	...\$19.50
-12	1/2	EAR916113	...\$19.50

90° Elbow

A	B	Part #	Price
-3	-3	EAR982103	...\$15.32
-4	-4	EAR982104	...\$15.32
-6	-6	EAR982106	...\$15.32
-8	-8	EAR982108	...\$16.47
-10	-10	EAR982110	...\$18.72
-12	-12	EAR982112	...\$21.99
-16	-16	EAR982116	...\$32.16

Flare Expanders Alum

A	B	Part #	Price
3	4	EAR9893034	...\$11.10
4	6	EAR9893046	...\$10.41
6	8	EAR9893068	...\$10.52
8	10	EAR9893810	...\$12.50
10	12	EAR9893102	...\$15.62
12	16	EAR9893126	...\$35.82
3	4	EAR9693034	...\$17.01 Steel

Carburetor / Power Steering Adapters

Carter/Edelbrock w/5/8-20 thread size

Adapter Size 9/16-24 hose end -6

EAR991941\$8.51

Single Inlet Holley

Adapter Size 9/16-24 hose end -6

EAR991942\$8.89

Dual Feed Holley

Adapter Size 7/8-20 hose end -6

EAR991943\$8.63

Weber

Adapter Size 12 mm x 1.50 hose end -6

EAR991944\$8.63

Dellorto/Solex/Mikuni

Adapter Size 12 mm x 1.25 hose end -6

EAR991945\$8.63

5/16 inverted flare/power steering/fuel pump

Adapter Size 1/2-20 hose end -6

Aluminum.....EAR991946...\$7.16

SteelEAR961946...\$11.18

3/8 inverted flare/power steering /fuel pump

Adapter Size 5/8-18 hose end -6

AluminumEAR991947...\$7.16

SteelEAR961947...\$11.18

Dual Feed Holley

Adapter Size 7/8-20 hose end -8

EAR991948\$9.17

Rochester

Adapter Size 7/8-20 hose end -6

EAR991949\$8.51

Rochester '75-up

Adapter Size 1-20 hose end -6

EAR991952\$8.45

Weber

Adapter Size 10 mm x 1 hose end -6

EAR991953\$8.75

Power steering/inverted flare

Adapter Size 11/16-18 hose end -6

AluminumEAR991950...\$6.90

SteelEAR961950...\$11.18

Dellorto/cupped banjo

Adapter Size 7mm banjo hose end -6

EAR991951\$10.51

Power Steering/Fuel Injection

O'Ring Seal 14mm x 1.5

EAR991954\$8.75

O'Ring Seal 16mm x 1.5

Aluminum.....EAR991955\$8.75

Steel.....EAR961955\$11.18

O'Ring Seal 18mm x 1.50 thread size

Aluminum.....EAR991956\$8.75

Steel.....EAR961956\$11.18

Fuel Injection Adapters

Dual Feed Holley/Remain with 7/8-20 thread size hose end -8

EAR991957\$9.11

Fuel Injection Female O-Ring Seal with Female 14mm x 1.5 thread size

EAR9894DBH\$7.59

Fuel Injection Female O-Ring Seal with Female 16mm x 1.5 thread size

EAR9894DBJ\$7.59

-8 AN Male Tee with -4 AN on Run

Blue AluminumEAR982484\$25.05

Black Aluminum.....EARAT982484...\$21.05

-6 AN Male to 9/16 Banjo...EAR977606...\$10.51

-4 AN Male to 9/16 Banjo...EAR977646...\$10.51

9/16 - 18 Bolt.....EAR97596...\$9.91



Flare Reducers

A	B	Part #	Price
-6	-4	EAR9892064	...\$9.81
-8	-4	EAR9892084	...\$11.57
-8	-6	EAR9892086	...\$10.07
-10	-4	EAR9892104	...\$13.08
-10	-6	EAR9892106	...\$12.43
-10	-8	EAR9892108	...\$12.81
-12	-6	EAR9892126	...\$13.74
-12	-8	EAR9892128	...\$13.14
-12	-10	EAR9892120	...\$19.50
-16	-10	EAR9892160	...\$24.22
-16	-12	EAR9892162	...\$25.87
-20	-16	EAR9892206	...\$46.00

Union Reducer

A	B	Part #	Price
-4	-3	EAR991902	...\$4.77
-5	-4	EAR991903	...\$6.36
-6	-4	EAR991906	...\$7.13
-6	-5	EAR991907	...\$7.26
-8	-6	EAR991912	...\$6.66
-10	-6	EAR991914	...\$9.43
-10	-8	EAR991915	...\$9.46
-12	-6	EAR991918	...\$14.14
-12	-8	EAR991919	...\$14.04
-12	-10	EAR991920	...\$14.14
-16	-10	EAR991922	...\$21.77
-16	-12	EAR991923	...\$18.95
-20	-16	EAR991924	...\$29.64

AN Reducer

A	B	Part #	Price
-10	-8	EAR989404	...\$20.08
-12	-8	EAR989409	...\$29.06
-12	-10	EAR989410	...\$29.06
-16	-12	EAR989411	...\$42.78
-4	-3	EAR989443	...\$11.57
-6	-4	EAR989464	...\$12.62
-8	-6	EAR989486	...\$13.67



Adapter Fittings / Aluminum

size	straight union	tee	o-ring port plug
-3	EAR981503...\$4.18	EAR982403...\$8.39	EAR581403*...\$4.38
-4	EAR981504...\$3.26	EAR982404...\$9.42	EAR581404*...\$5.35
-6	EAR981506...\$5.23	EAR982406...\$9.42	EAR581406*...\$5.35
-8	EAR981508...\$5.97	EAR982408...\$15.79	EAR981408...\$4.06
-10	EAR981510...\$7.98	EAR982410...\$20.00	EAR981410...\$6.09
-12	EAR981512...\$12.72	EAR982412...\$30.05	EAR981412...\$8.34
-16	EAR981516...\$21.80	EAR982416...\$50.82	EAR981416...\$10.77
-20	EAR981520...\$31.88		

Steel

size	tee
-3	EAR962403...\$7.34
-4	EAR962404...\$7.34

***2 per package**



Hose Barb to Pipe Thread Adapters / Alum

Hose	NPT	straight	45°	90°
1/4	1/8	EAR984004...\$5.14	EAR984404...\$19.72	EAR984204...\$14.65
3/8	1/4	EAR984006...\$5.33	EAR984406...\$19.89	EAR984206...\$17.67
1/2	3/8	EAR984008...\$8.53	EAR984408...\$20.17	EAR984208...\$18.06
5/8	1/2	EAR984010...\$12.65	EAR984410...\$24.68	EAR984210...\$19.43
3/4	3/4	EAR984012...\$18.73	EAR984412...\$38.54	EAR984212...\$27.78



AN to AN Bulkhead Fittings / Aluminum

size	straight	45°	90°	Bulkhead Tee	Tee on the run	Nut
-3	EAR983203...\$6.29	EAR983703...\$9.65	EAR983303...\$8.39	EAR983403...\$16.84	EAR980403...\$13.44	EAR592403*...\$3.97
-4	EAR983204...\$5.44	EAR983704...\$8.39	EAR983304...\$7.16	EAR983404...\$13.21	EAR980404...\$13.70	EAR592404*...\$3.97
-6	EAR983206...\$6.04	EAR983706...\$11.57	EAR983306...\$9.87	EAR983406...\$15.44	EAR980406...\$13.91	EAR592406*...\$3.97
-8	EAR983208...\$7.54	EAR983708...\$15.78	EAR983308...\$14.29	EAR983408...\$19.43	EAR980408...\$21.43	EAR992408...\$3.64
-10	EAR983210...\$11.24	EAR983710...\$19.53	EAR983310...\$18.73	EAR983410...\$19.08		EAR992410...\$3.87
-12	EAR983212...\$14.86	EAR983712...\$28.79	EAR983312...\$28.96	EAR983412...\$37.25		EAR992412...\$3.67
-16	EAR983216...\$28.63		EAR983316...\$42.15			EAR992416...\$6.54

AN to AN Bulkhead Fittings / Steel

size	straight	45°	90°	Bulkhead Tee	Tee on the run	Nut
-3	EAR963203...\$7.34	EAR963703...\$6.95	EAR963303...\$6.95	EAR963403...\$6.95	EAR960403...\$25.69	EAR502403*...\$6.98
-4	EAR963204...\$6.95					EAR502404*...\$6.98

***2 per package**



Banjos

AN size	Hole Dia	Tube Size	Part #	Price
-3	3/8		EAR997603	\$8.27
-4	7/16		EAR997604	\$9.09
-3	10mm		EAR997631	\$8.30
-3	7/16		EAR997634	\$8.54
-3	12mm		EAR997635	\$8.51
-4	10mm		EAR997641	\$9.36
-4	3/8		EAR997643	\$9.36

Brake

Adapter/Steel IF=Inverted flare

-3 to 10mm x1.0	EAR592032	\$12.26
-3 to 10mm x1.25 IF	EAR592035	\$12.26
-4 to 10mm x1.0	EAR592042	\$13.62
-4 to 10mm x1.25 IF	EAR592045	\$12.26
-4 to 7/16-20 IF	EAR591941	\$10.87
-3 to 3/8-24 IF short	EAR581531	\$9.79
-3 to 7/16-24 IF	EAR591932	\$10.87
-4 to 7/16-24 IF	EAR591942	\$13.14
-4 to 3/8-24 IF short	EAR591972	\$12.26
-4 to 3/8-24 IF long	EAR591982	\$12.26
-3 to -4	EAR501902	\$9.75

Brass "T"

w/ mounting hole

3/8" - 24 IF on all 3 ends	EAR972052	\$12.63
3/8" - 24 IF on sides, 3/8" - 24 straight on T	EAR972050	\$12.63

T-Brake Adapter

7/16-24 I.F. on one run, 3/8-24 other run and branch, 7/16 mounting hole. EAR972051\$12.63

Hyperfirm Brake Line Adapter T - Style .375 in.-24 I.F. On Branch 3 AN Male On One Run .4375 in.-I.F. On Other Run EAR972051A\$16.29

Hyperfirm Brake Line Adapter T - Style #3 AN Male On Branch .375 in. -24 I.F. On One Run .4375 in.-24 On Other Run EAR972051B\$16.29

Bare Alum/Style B Female Outlets

Inlet	Outlet	Part #	Price
10 AN	10 AN (2)	EAR100176	\$51.15
3/8 NPT	1/4 NPT (2)	EAR100179	\$26.33
1/2 NPT	3/8 NPT (2)	EAR100183	\$51.15
1/2 NPT	1/2 NPT (2)	EAR100184	\$51.15

Bare Alum/Style B Male Outlets

Inlet	Outlet	Part #	Price
3/8 NPT	-6 AN Male	EAR100181	\$34.77

Line Clamps Polished

Clamp I.D. Size

3/16" .6 Qty	EAR170203	\$21.04
1/4" .6 Qty	EAR170204	\$21.04
5/16" .6 Qty	EAR170205	\$21.04
3/8" .4 Qty	EAR170206	\$21.04
7/16" .4 Qty	EAR170207	\$21.04
1/2" .3 Qty	EAR170208	\$21.04
9/16" .3 Qty	EAR170209	\$21.04

Hose & Tubing Separators

Crafted from 6061-T6 billet alum alloy these clamps are the finest available to finish off a professional plumbing installation. Clamps come with counter sunk allen head screws in a variety of colors and sizes for separating, isolating and securing fuel, oil and brake lines.

Long Banjos

Hole: 3/8"-10mm, Height: 10mm

Lg. Rd Banjo	EAR9978031	\$11.86
Lg. 15' Rd Banjo	EAR9978033	\$13.26
Lg. 30' Rd Banjo	EAR9978034	\$13.26
Lg. 40' Rd Banjo	EAR9978035	\$13.26
Lg. 25' Side Rd Banjo	EAR9978036	\$13.26

Banjo Bolts

(includes 2 crush washers)

Thread Size	Banjo Hole	Price
3/8-24 single	3/8	EAR977503 \$5.58
7/16-20 single	7/16	EAR977504 \$5.58
3/8-24 double for 2 banjos	3/8	EAR977513 \$6.51
7/16-20 double for 2 banjos	7/16	EAR977514 \$6.51
10mm x1.25 single	10mm	EAR977515 \$5.58
10mm x 1.0 single	10mm	EAR977517 \$5.58
10mm x 1.25 double	10mm	EAR977518 \$6.51
10mm x 1.0 double	10mm	EAR977519 \$6.51
10mm x 1.50 single	10mm	EAR977520 \$6.51
7/16-24 single	7/16	EAR977522 \$5.58

Tubing Adapter

-3 to 3/8-24 Fem	EAR989531	\$5.85
-4 to 3/8-24 Fem	EAR989541	\$5.85
-3 to 3/8-24 IF	EAR989543	\$5.85
-4 to Fem 10mm x 1.0 IF	EAR989544	\$6.92
-3 to 10mm x1.0 Fem	EAR989534	\$5.85
-3 to 10mm x1.25	EAR989535	\$5.85
-3 to 10mm x 1.0 IF Honda	EAR989537	\$5.85
-3 to 10mm x1.0 IF	EAR989545	\$5.85
-3 to 10mm x1.25 IF	EAR989536	\$5.55
-4 to 3/8-24 IF	EAR989542	\$5.85
-4 to 10mm x1.0	EAR989542	\$6.92
-4 to 7/16-24 IF	EAR989548	\$6.29
-3 to 7/16-24 IF	EAR989549	\$6.29

Straight Transmission Oil Cooler Adapter

Nickel Plated Steel Construction. High Pressure Capabilities.

-6 Male to 1/4-18 NPSM Male -Short (Front)	EAR961980	\$10.51
-6 Male to 9/16-18 Threads -Long (Rear)	EAR961983	\$10.51
-6 Male to 9/16-18 Threads -Short (Front)	EAR961982	\$10.51
-6 Male to 1/4-18 NPSM Male -Long (Rear)	EAR961981	\$10.51
-6 Male to 1/4-18 NPSM Male	EAR940006	\$18.95

10' Alum Tubing

Easily hand formed. Can be flared and used with nut and sleeve. 100 psi max pressure, not for brakes. 10' length.

3/8 aluminum line	EAR100034	\$17.89
1/2 aluminum line	EAR100037	\$20.98

25' Brake Line

3/16 steel line	BSC70300	\$22.77
1/4 steel line	BSC70400	\$22.75

25' Alum Fuel Line

3/8 aluminum line	MOR65330	\$30.25
1/2 aluminum line	MOR65340	\$38.02
5/8 aluminum line	MOR65345	\$46.53

(not for use w/high pressure fuel injection systems)

Size	Red Anodized	Polished
3/16 (3 Qty)	EAR167003 \$18.02	EAR167203 \$18.02
1/4 (3 Qty)	EAR167004 \$18.02	EAR167204 \$18.02
5/16 (3 Qty)	EAR167005 \$18.02	EAR167205 \$18.02
3/8 (2 Qty)	EAR167006 \$18.02	EAR167206 \$18.02
7/16 (2 Qty)	EAR167007 \$18.02	EAR167207 \$18.02
1/2 (2 Qty)	EAR167008 \$18.02	EAR167208 \$18.02
9/16 (2 Qty)	EAR167009 \$18.02	EAR167209 \$18.02
5/8 (2 Qty)	EAR167010 \$18.02	EAR167210 \$18.02
11/16 (2 Qty)	EAR167011 \$18.02	EAR167211 \$18.02
3/4 (2 Qty)	EAR167012 \$18.02	EAR167212 \$18.02
13/16 (2 Qty)	EAR167013 \$18.02	EAR167213 \$18.02
7/8 (2 Qty)	EAR167014 \$18.02	EAR167214 \$18.02
15/16 (2 Qty)	EAR167015 \$18.02	EAR167215 \$18.02
1 (2 Qty)	EAR167016 \$18.02	EAR167216 \$18.02
17/32 (2 Qty)	EAR167019 \$18.02	EAR167219 \$18.02
19/32 (2 Qty)	EAR167020 \$18.27	EAR167220 \$18.27
21/32 (2 Qty)	EAR167022 \$18.02	EAR167222 \$18.02

O-Rings

Buna N is compatible with most fuels, hydraulic fluids and lubricants up to 275° F. Viton is preferred for synthetic lubricants, oxygen bearing fuels and non-ether based brake fluids. It also has a longer service life and a temp rating of 400°F.

Size	Qty	Buna N #	Viton #
-3	10	EAR176003 \$4.17	EAR176103 \$4.17
-4	10	EAR176004 \$4.17	EAR176104 \$4.17
-6	10	EAR176006 \$4.17	EAR176106 \$4.17
-8	10	EAR176008 \$4.17	EAR176108 \$4.17
-10	5	EAR176010 \$4.17	EAR176110 \$4.17
-12	5	EAR176012 \$4.17	EAR176112 \$5.22
-16	5	EAR176016 \$4.17	EAR176116 \$5.22

AN 901

Aluminum Crush Washers

AN size	ID	Per Pk	Part #	Price
-3	3/8	10	EAR177003	\$6.28
-4	7/16	10	EAR177004	\$6.28
-5	1/2	10	EAR177005	\$6.28
-6	9/16	10	EAR177006	\$6.28
-8	3/4	5	EAR177008	\$6.28
-10	7/8	5	EAR177010	\$6.28
-12	1 1/16	5	EAR177012	\$6.28
-16	1 5/16	2	EAR177016	\$6.28
10mm	10mm	10	EAR177100	\$6.28

Stat-O-Seals

The very best sealing washer available. A synthetic rubber o-ring locked to the ID of an aluminum washer. Provides a positive seal from -85 to 450°F.

AN size	ID	Per Pk	Part #	Price
-	3/16	2	EAR178003	\$5.84
-	1/4	2	EAR178004	\$5.84
-	5/16	2	EAR178005	\$5.84
-3	3/8	2	EAR178006	\$4.31
-4	7/16	2	EAR178007	\$5.84
-5	1/2	2	EAR178008	\$5.40
-6	9/16	2	EAR178009	\$5.40
-	5/8	2	EAR178010	\$9.65
-8	3/4	2	EAR178012	\$9.65
-10	7/8	2	EAR178014	\$13.35

Dowty Seals

The English version of our Stat-O-Seal, the Dowty Seal is considerably smaller in diameter & thicker in cross section.

AN size	ID	Per Pk	Part #	Price
-	3/16	2	EAR178103	\$5.84
-	1/4	2	EAR178104	\$5.84
-	5/16	2	EAR178105	\$5.84
-3	3/8	2	EAR178106	\$5.84
-4	7/16	2	EAR178107	\$5.84
-5	1/2	2	EAR178108	\$7.50
-6	9/16	2	EAR178109	\$8.72
-	5/8	2	EAR178110	\$9.65
-8	3/4	2	EAR178112	\$7.57
-10	7/8	2	EAR178114	\$13.35
-12	1 1/16	2	EAR178117	\$21.03

NPT Plug/Alum	AN Cap / Alum
1/16 EAR593201 \$6.57	-3 EAR592903 \$5.97
1/8 EAR593202 \$5.84	-4 EAR592904 \$5.97
3/8 EAR593203 \$5.84	-6 EAR592906 \$5.97
1/4 EAR593204 \$6.92	-8 EAR592908 \$4.77
1/2 EAR993205 \$4.15	-10 EAR992910 \$6.20
3/4 EAR993206 \$4.96	-12 EAR992912 \$8.99
	-16 EAR992916 \$10.47
	-20 EAR992920 \$25.27

NPT Plug Hex Head

1/8	EAR993301	\$3.43
1/4	EAR993302	\$3.96
3/8	EAR993303	\$4.80
1/2	EAR993304	\$5.85
3/4	EAR993306	\$6.92

Pipe Plugs

8 Piece Kit can be used to plug vacuum accessory holes for intake manifolds or fill plug holes in transmissions and rear ends. Socket Head Chrome Plated Steel. 8-Piece Set - Includes: (2) 1/8" NPT (2) 1/4" NPT (2) 3/8" NPT (2) 1/2" NPT. MRG6352G\$15.48

Swivel-Seal hose ends have a unique nipple and cutter design, a design aerospace proven for over 45 years. Tightening the ferrule pulls the hose into a sharp cutter providing an unsurpassed seal. Most common uses for the Swivel-Seal are fuel lines and remote oil filter or dry sump lines. For use with Perform-O-Flex or Pro-Lite 350 hose only.



Ano-Tuff Swivel-Seal Hose Ends

size	straight	30°	45°	45° Low Profile	90°	90° Low Profile
-6	EARAT800106 \$8.65	EARAT803106 .\$23.50	EARAT804606 .\$27.38	EARAT804506 .\$30.85	EARAT809106 .\$27.38	EARAT809006 .\$27.38
-8	EARAT800108 \$11.57	EARAT803108 .\$28.01	EARAT804608 .\$26.58	EARAT804508 .\$35.11	EARAT809108 .\$29.50	EARAT809008 .\$29.50
-10	EARAT800110 \$13.67	EARAT803110 .\$31.70	EARAT804610 .\$31.61	EARAT804510 .\$35.79	EARAT809110 .\$31.61	EARAT809010 .\$31.61
-12	EARAT800112 \$18.90	EARAT803112 .\$42.09	EARAT804612 .\$37.93	EARAT804512 .\$53.60	EARAT809112 .\$37.93	EARAT809012 .\$37.93
-16	EARAT800116 \$30.55	EARAT803116 .\$52.62	EARAT804616 .\$48.48	EARAT804516 .\$77.77	EARAT809116 .\$48.48	EARAT809016 .\$52.70



Use with Perform-O-Flex or Pro-Lite 350

size	120°	150°	180°
-6	EARAT812006 \$27.38	EARAT815006 .\$27.38	EARAT818006 .\$27.38
-8	EARAT812008 \$29.50	EARAT815008 .\$29.50	EARAT818008 .\$29.50
-10	EARAT812010 \$31.61	EARAT815010 .\$31.61	EARAT818010 .\$31.61
-12	EARAT812012 \$37.93	EARAT815012 .\$37.93	EARAT818012 .\$37.93
-16	EARAT812016 \$48.48	EARAT815016 .\$48.48	EARAT818016 .\$48.48



Auto-Mate hose ends are still the best barbed aluminum nipple hose ends. Used with the Econo-O-Fit hose clamp cover, they provide a great look and a sure seal for most applications of fuel and oil lines, heater and water hoses, or crankcase vents. They make a great hose end for street or show. For use with Perform-O-Flex or Pro-Lite 350 hose only.

Use with Perform-O-Flex or Pro-Lite 350



Ano-Tuff Auto-Mate Hose Ends

size	straight	45°	90°	120°	150°	180°
-4	EARAT700104 \$8.39	EARAT704604 \$20.61	EARAT709104 \$20.61	EARAT712004 \$22.18	EARAT715004 \$22.18	EARAT718004 \$22.18
-6	EARAT700106 \$8.12	EARAT704606 \$20.61	EARAT709106 \$20.61	EARAT712006 \$22.08	EARAT715006 \$22.08	EARAT718006 \$22.08
-8	EARAT700108 \$8.09	EARAT704608 \$22.08	EARAT709108 \$22.08	EARAT712008 \$27.58	EARAT715008 \$27.58	EARAT718008 \$27.58
-10	EARAT700110 \$11.50	EARAT704610 \$28.03	EARAT709110 \$28.03	EARAT712010 \$32.55	EARAT715010 \$30.91	EARAT718010 \$32.55
-12	EARAT700112 \$17.74	EARAT704612 \$32.06	EARAT709112 \$32.06	EARAT712012 \$36.22	EARAT715012 \$36.22	EARAT718012 \$38.12
-16	EARAT700116 \$25.73	EARAT704616 \$41.09	EARAT709116 \$41.09	EARAT712016 \$49.17	EARAT715016 \$46.71	EARAT718016 \$49.17

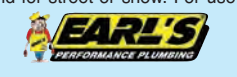

Perform-O-Flex SS Braided Hose

size	3'	6'	10'	20'	33'
-4	EAR403004 .\$25.26	EAR406004 .\$46.37	EAR410004 .\$74.85	EAR420004 .\$147.95	EAR433004 .\$239.95
-6	EAR403006 .\$28.42	EAR406006 .\$52.68	EAR410006 .\$86.43	EAR420006 .\$168.95	EAR433006 .\$276.95
-8	EAR403008 .\$31.60	EAR406008 .\$60.07	EAR410008 .\$98.06	EAR420008 .\$193.95	EAR433008 .\$316.95
-10	EAR403010 .\$34.76	EAR406010 .\$66.40	EAR410010 .\$109.95	EAR420010 .\$213.95	EAR433010 .\$350.95
-12	EAR403012 .\$37.92	EAR406012 .\$72.73	EAR410012 .\$119.95	EAR420012 .\$234.95	EAR433012 .\$384.95
-16	EAR403016 .\$48.47	EAR406016 .\$93.82	EAR410016 .\$155.95	EAR420016 .\$306.95	EAR433016 .\$502.95
-20	EAR403020 .\$66.39	EAR406020 .\$130.95	EAR410020 .\$213.95	EAR420020 .\$422.95	
-24	EAR403024 .\$81.88	EAR406024 .\$153.95	EAR410024 .\$255.95	EAR420024 .\$511.95	

Male AN Threads

Thread Hose Size	Size	Size straight
AN-6	6	EARAT840106 .\$13.36
AN-8	8	EARAT840108 .\$17.54
AN-10	10	EARAT840110 .\$18.87
AN-12	12	EARAT840112 .\$21.92

Pro-Lite 350 Braided Hose

size	3'	6'	10'	20'	33'
-4	EAR350304 .\$25.26	EAR350604 .\$47.42	EAR351004 .\$76.94	EAR352004 .\$151.95	EAR353304 .\$245.95
-6	EAR350306 .\$28.43	EAR350606 .\$53.74	EAR351006 .\$87.50	EAR352006 .\$170.95	EAR353306 .\$280.95
-8	EAR350308 .\$31.60	EAR350608 .\$60.07	EAR351008 .\$98.04	EAR352008 .\$193.95	EAR353308 .\$315.95
-10	EAR350310 .\$34.76	EAR350610 .\$66.40	EAR351010 .\$109.95	EAR352010 .\$215.95	EAR353310 .\$350.95
-12	EAR350312 .\$37.92	EAR350612 .\$72.73	EAR351012 .\$119.95	EAR352012 .\$235.95	EAR353312 .\$384.95
-16	EAR350316 .\$47.42	EAR350616 .\$91.73	EAR351016 .\$151.95	EAR352016 .\$298.95	EAR353316 .\$489.95
-20	EAR350320 .\$66.40	EAR350620 .\$130.95	EAR351020 .\$215.95	EAR352020 .\$425.95	EAR353320 .\$698.95

Thread Hose Size	Size	Size 90°
AN-6	6	EARAT849006 .\$34.45
AN-8	8	EARAT849008 .\$39.83
AN-10	10	EARAT849010 .\$43.02

Aluminum AN Fitting Wrench -3 to -16

It is CNC machined from true aerospace grade 7075 billet aluminum and features a precision mechanism with a Steel Nickel knurled thumbwheel. Quick size adjustment make it ideal for use in the pit area, staging lanes, or back at the shop. Fits AN -3 to -16 hose ends. EAR230400...**\$56.27**



AN Thread Size

AN	Tube OD	Thread
-2	1/8	5/16-24
-3	3/16	3/8-24
-4	1/4	7/16-20
-5	5/16	1/2-20
-6	3/8	9/16-18
-8	1/2	3/4-16
-10	5/8	7/8-14
-12	3/4	1 1/8-12
-16	1	1 5/8-12
-20	1 1/4	1 5/8-12
-24	1 1/2	1 7/8-12
-28	1 3/4	2 1/4-12
-32	2	2 1/2-12

Thread Size	Hose Size...Straight
1/4	6...EARAT820106 .\$14.62
3/8	6...EARAT820166 .\$17.64
3/8	8...EARAT820108 .\$17.67
1/2	10...EARAT820110 .\$23.04

Thread Size	Hose Size	Size 90°
1/4	6	EARAT829006 .\$32.23
3/8	6	EARAT829066 .\$34.46
3/8	8	EARAT829008 .\$39.83
1/2 NPT	10	EARAT829010 .\$41.68



Swivel-Seal and Auto-Fit Replacement Sockets

Hose size	size	price
4	12	EARAT898123\$5.68
6	16	EARAT898163\$10.00
8	20	EARAT898203\$17.11
10	24	EARAT898243\$37.52



Carb Adapter for Holley

7/8-20 Dual Feed Holley
Thread to -8 AN. 3" long.
EARAT915383L.....\$19.79



AN to AN Adapters

Female AN Tee ("O" Ring Seal)

A	B	C	Part #	
-4	-4	-4	EARAT993804\$12.70
-6	-6	-6	EARAT993806\$12.70
-8	-8	-8	EARAT993808\$17.60
-10	-10	-10	EARAT993810\$26.29
-12	-12	-12	EARAT993812\$35.54

Adapter Fitting Aluminum

straight female swivel

-3	EARAT915103\$9.45
-4	EARAT915104\$8.02
-6	EARAT915106\$7.82
-8	EARAT915108\$9.20
-10	EARAT915110\$12.12
-12	EARAT915112\$16.49
-16	EARAT915116\$22.75



Tube Nut/Aluminum

AN size Tube Size

-3	3/16	EARAT581803\$4.97
-4	1/4	EARAT581804\$4.97
-6	3/8	EARAT581806\$3.66
-8	1/2	EARAT981808\$2.41
-10	5/8	EARAT981810\$3.37
-12	3/4	EARAT981812\$4.09
-16	1	EARAT981816\$7.10



Tube Sleeve/Aluminum

AN size Tube Size

-3	3/16	EARAT581903\$3.18
-4	1/4	EARAT581904\$3.36
-5	5/16	EARAT581905\$4.34
-6	3/8	EARAT581906\$3.37
-8	1/2	EARAT981908\$1.76
-10	5/8	EARAT981910\$2.27



NPT Plug/Aluminum

1/16	EARAT593201	..\$6.62
1/8	EARAT593202	..\$5.85
1/4	EARAT593203	..\$5.85
3/8	EARAT593204	..\$6.92
1/2	EARAT993205	..\$4.34
3/4	EARAT993206	..\$5.81



AN Cap / Aluminum

-3	EARAT592903	..\$5.97
-4	EARAT592904	..\$5.97
-6	EARAT592906	..\$5.97
-8	EARAT992908	..\$5.54
-10	EARAT992910	..\$6.16
-12	EARAT992912	..\$8.89
-16	EARAT992916	..\$11.13
-20	EARAT992920	..\$22.76



NPT Plug Hex Head

1/8	EARAT993301\$3.43
1/4	EARAT993302\$3.94
3/8	EARAT993303\$3.94
1/2	EARAT993304\$5.51
3/4	EARAT993306\$6.50



Carburetor / Power Steering Adapters

Single Inlet Holley

Adapter Size 9/16-24 • hose end -6
EARAT991942...\$10.20



Dual Feed Holley

Adapter Size 7/8-20 • hose end -6
EARAT991943...\$9.12



Weber

Adapter Size 12 mm x 1.50 • hose end -6
EARAT991944...\$9.91



Dellorto/Solex/Mikuni

Adapter Size 12 mm x 1.25 • hose end -6
EARAT991945...\$11.28



5/16 inverted flare / power steering / fuel pump

Adapter Size 1/2-20 • hose end -6
EARAT991946...\$7.89



3/8 inverted flare / power steering / fuel pump

Adapter Size 5/8-18 • hose end -6
EARAT991947...\$7.89



Dual Feed Holley

Adapter Size 7/8-20 • hose end -8
EARAT991948...\$10.67



Weber

Adapter Size 10 mm x 1
hose end -6
EARAT991953...\$9.91



Flare Expanders

A	B	Part #	
3	4	EARAT9893034\$12.36
4	6	EARAT9893046\$10.25
6	8	EARAT9893068\$11.44
8	10	EARAT9893810\$13.48
10	12	EARAT9893102\$17.30
12	16	EARAT9893126\$35.82



Carburetor, Power Steering, Fuel Pumps, Fuel Injection

-8 AN Male to 3/4"-16 Male...EARAT991958...\$10.48
-6 AN Male to 3/4"-16 Male...EARAT991959...\$9.72

Power Steering/Fuel Injection

O'Ring Seal 14mm x 1.5
EARAT991954...\$9.20
O'Ring Seal 16mm x 1.5
EARAT991955...\$9.91
O'Ring Seal 18mm x 1.50 thread size
EARAT991956...\$9.91
Dual Feed Holley/Reman with 7/8-20 thread size
EARAT991957...\$10.23



Fuel Shut-Off Valve

inlet	outlet	
3/8 NPT	-6	EARAT230502...\$42.03
3/8 NPT	-8	EARAT230503...\$42.03
1/2 NPT	-10	EARAT230505...\$54.57



Aluminum Tubing Adapters

"A"....."B".....Part #

-6 AN Male5/16"	EARAT165056	..\$11.33
-6 AN Male1/4"	EARAT165064	..\$11.41
-6 AN Male3/8"	EARAT165006	..\$11.33
-8 AN Male3/8"	EARAT165086	..\$13.67
-8 AN Male1/2"	EARAT165008	..\$12.62
-10 AN Male1/2"	EARAT165010	..\$15.76
-6 AN Female5/16"	EARAT165156	..\$10.73
-6 AN Female3/8"	EARAT165106	..\$11.55
-8 AN Female1/2"	EARAT165108	..\$13.64
-10 AN Female5/8"	EARAT165110	..\$18.64



Replacement Compression Sleeves

Tubing size

1/4"	EAR165040\$2.96
5/16"	EAR165050\$2.96
3/8"	EAR165060\$2.96
1/2"	EAR165080\$3.97
5/8"	EAR165100\$3.97



Adapter Fittings / Aluminum

*2 per package

size	straight union	tee	o-ring port plug
-3	EARAT981503 \$6.07	EARAT982403 \$8.39	EARAT581403* \$4.69
-4	EARAT981504 \$3.28	EARAT982404 \$9.42	EARAT581404* \$5.51
-6	EARAT981506 \$5.23	EARAT982406 \$9.42	EARAT581406* \$5.51
-8	EARAT981508 \$5.97	EARAT982408 \$15.78	EARAT981408 \$4.06
-10	EARAT981510 \$7.98	EARAT982410 \$20.00	EARAT981410 \$6.09
-12	EARAT981512 \$12.46	EARAT982412 \$30.05	EARAT981412 \$8.94
-16	EARAT981516 \$21.40	EARAT982416 \$51.17	EARAT981416 \$11.35

Hose Barb to Pipe Thread Adapters / Alum

Hose	NPT	straight	45°	90°
1/4	1/8	EARAT984004 \$5.95	EARAT984404 \$19.72	EARAT984204 \$16.40
3/8	1/4	EARAT984006 \$6.17	EARAT984406 \$19.89	EARAT984206 \$19.06
1/2	3/8	EARAT984008 \$8.33	EARAT984408 \$20.08	EARAT984208 \$20.08
5/8	1/2	EARAT984010 \$12.39	EARAT984410 \$24.68	EARAT984210 \$21.57
3/4	3/4	EARAT984012 \$21.09	EARAT984412 \$38.54	EARAT984212 \$30.85

AN to AN Bulkhead Fittings / Aluminum

size	straight	45°	90°
-3	EARAT983203...\$6.29	EARAT983703...\$10.25	EARAT983303...\$10.25
-4	EARAT983204...\$5.87	EARAT983704...\$9.20	EARAT983304...\$7.92
-6	EARAT983206...\$6.36	EARAT983706...\$16.84	EARAT983306...\$10.25
-8	EARAT983208...\$8.27	EARAT983708...\$17.89	EARAT983308...\$15.27
-10	EARAT983210...\$12.21	EARAT983710...\$20.27	EARAT983310...\$20.27
-12	EARAT983212...\$15.27	EARAT983712...\$27.38	EARAT983312...\$30.60
-16	EARAT983216...\$30.60		EARAT983316...\$42.15

Bulkhead Tee

EARAT983403	..\$16.84
EARAT983404	..\$13.67
EARAT983406	..\$14.73
EARAT983408	..\$18.95
EARAT983410	..\$20.00
EARAT983412	..\$37.25

Nut

EARAT592403*	..\$3.97
EARAT592404*	..\$3.97
EARAT592406*	..\$5.97
EARAT992408	..\$3.15
EARAT992410	..\$3.22
EARAT992412	..\$3.37
EARAT992416	..\$6.95

Pipe Thread to AN Adapters

Pipe Thread to AN Adapters Straight

size	NPT	aluminum straight	
-3	1/8	EARAT981603.....\$3.20	
-4	1/8	EARAT981604.....\$3.49	
-4	1/4	EARAT981644.....\$5.23	
-6	1/8	EARAT981662.....\$5.07	
-6	1/4	EARAT981606.....\$4.18	
-6	3/8	EARAT981666.....\$5.47	
-6	1/2	EARAT981668.....\$6.32	
-8	1/4	EARAT981607.....\$5.18	
-8	3/8	EARAT981608.....\$5.57	
-8	1/2	EARAT981688.....\$6.50	
-10	3/8	EARAT981611.....\$6.54	
-10	1/2	EARAT981610.....\$7.48	
-10	3/4	EARAT981609.....\$10.48	
-12	1/2	EARAT981613.....\$10.95	
-12	3/4	EARAT981612.....\$11.35	
-16	3/4	EARAT981615.....\$21.05	
-16	1	EARAT981616.....\$21.96	
-20	1 1/4	EARAT981620.....\$28.44	

Pipe Thread to AN Adapters - 45°

size	NPT	aluminum 45°	
-3	1/8	EARAT982303.....\$8.39	
-4	1/8	EARAT982304.....\$9.20	
-4	1/4	EARAT982344.....\$14.84	
-6	1/8	EARAT982362.....\$19.97	
-6	1/4	EARAT982306.....\$8.39	
-6	3/8	EARAT982366.....\$11.57	
-6	1/2	EARAT982368.....\$17.89	
-8	1/4	EARAT982307.....\$16.61	
-8	3/8	EARAT982308.....\$10.51	
-8	1/2	EARAT982388.....\$16.34	
-10	3/8	EARAT982311.....\$15.78	
-10	1/2	EARAT982310.....\$15.78	
-10	3/4	EARAT982309.....\$24.22	
-12	1/2	EARAT982313.....\$23.78	
-12	3/4	EARAT982312.....\$23.78	
-16	1	EARAT982316.....\$35.82	

Pipe Thread to AN Adapters - 90°

size	NPT	aluminum 90°	
-3	1/8	EARAT982203.....\$8.39	
-4	1/8	EARAT982204.....\$8.39	
-4	1/4	EARAT982244.....\$8.39	
-6	1/8	EARAT982262.....\$9.79	
-6	1/4	EARAT982206.....\$8.39	
-6	3/8	EARAT982266.....\$10.51	
-6	1/2	EARAT982268.....\$16.84	
-8	1/4	EARAT982207.....\$14.87	
-8	3/8	EARAT982208.....\$10.51	
-8	1/2	EARAT982288.....\$15.78	
-10	3/8	EARAT982211.....\$17.89	
-10	1/2	EARAT982210.....\$17.00	
-10	3/4	EARAT982209.....\$24.20	
-12	1/2	EARAT982213.....\$21.05	
-12	3/4	EARAT982212.....\$21.05	
-16	3/4	EARAT982215.....\$33.71	
-16	1	EARAT982216.....\$35.82	

Tee-Pipe Thread on Side

A	B	C	aluminum	
-3	-3	1/8	EARAT982503.....\$10.51	
-4	-4	1/8	EARAT982504.....\$10.51	
-6	-6	1/4	EARAT982506.....\$11.67	
-8	-8	3/8	EARAT982508.....\$17.00	
-10	-10	1/2	EARAT982510.....\$18.95	
-12	-12	3/4	EARAT982512.....\$31.61	

Tee-Pipe Thread on Run

A	B	C	aluminum	
1/8	-3	-3	EARAT982603.....\$10.51	
1/8	-4	-4	EARAT982604.....\$10.51	
1/4	-6	-6	EARAT982606.....\$10.51	
3/8	-8	-8	EARAT982608.....\$16.84	
1/2	-10	-10	EARAT982610.....\$20.27	
3/4	-12	-12	EARAT982612.....\$30.55	
1	-12	-12	EARAT982616.....\$52.70	

Flare Reducers

A	B		
-6	-4	EARAT9892064.....\$11.09	
-8	-4	EARAT9892084.....\$11.21	
-8	-6	EARAT9892086.....\$11.21	
-10	-4	EARAT9892104.....\$14.10	
-10	-6	EARAT9892106.....\$12.43	
-10	-8	EARAT9892108.....\$12.81	
-12	-6	EARAT9892126.....\$13.74	
-12	-8	EARAT9892128.....\$15.78	
-12	-10	EARAT9892120.....\$19.50	
-16	-10	EARAT9892160.....\$24.22	
-16	-12	EARAT9892162.....\$25.87	
-20	-16	EARAT9892206.....\$46.00	

AN Reducer

A	B	
-10	-8	EARAT989404.....\$22.05
-12	-8	EARAT989409.....\$30.21
-12	-10	EARAT989410.....\$30.21
-12	-10	EARAT989411.....\$42.78
-16	-10	EARAT989443.....\$12.08
-16	-12	EARAT989464.....\$12.62
-8	-6	EARAT989486.....\$14.45

Pipe Thread to Pipe Thread Adapters

NPT to NPT Adapters

size	Male	Female	
1/8	EARAT991101.....\$4.90	EARAT991001.....\$5.59	
1/4	EARAT991102.....\$5.98	EARAT991002.....\$7.92	
3/8	EARAT991103.....\$9.29	EARAT991003.....\$10.07	
1/2	EARAT991104.....\$11.19	EARAT991004.....\$11.34	
3/4	EARAT991106.....\$13.08	EARAT991006.....\$17.83	

45° Elbow

Internal/External Pipe Thread			
A	B	Part #	
1/8	1/8	EARAT991501.....\$12.62	
1/4	1/4	EARAT991502.....\$14.73	
3/8	3/8	EARAT991503.....\$21.05	

90° Elbow

Internal/External Pipe Thread			
A	B	Part #	
1/8	1/8	EARAT991401.....\$12.62	
1/4	1/4	EARAT991402.....\$14.73	
3/8	3/8	EARAT991403.....\$21.05	

90° Elbow

Internal Pipe Thread			
A	B	Part #	
1/8	1/8	EARAT991601.....\$10.51	
1/4	1/4	EARAT991602.....\$15.78	
3/8	3/8	EARAT991603.....\$21.05	

NPT Female Tee

NPT size		
1/8	EARAT991701.....\$10.51	
1/4	EARAT991702.....\$13.67	
3/8	EARAT991703.....\$15.78	

NPT Reducer Bushing

Female	Male	
1/8	1/4	EARAT991201.....\$5.98
1/4	3/8	EARAT991202.....\$7.65
1/8	3/8	EARAT991203.....\$7.09
3/8	1/2	EARAT991204.....\$7.65
1/4	1/2	EARAT991205.....\$9.06
1/8	1/2	EARAT991206.....\$9.93
1/2	3/4	EARAT991207.....\$11.19
3/8	3/4	EARAT991208.....\$11.19
1/4	3/4	EARAT991209.....\$12.94
3/4	1	EARAT991210.....\$16.59
1/2	1	EARAT991211.....\$16.59
3/8	1	EARAT991212.....\$16.59
3/4	1 1/4	EARAT991213.....\$29.07

Straight AN Swivel to Male NPT

A	B	Part #	
-3	1/8	EARAT916103.....\$11.27	
-4	1/8	EARAT916104.....\$9.20	
-4	1/4	EARAT916144.....\$9.34	
-6	1/4	EARAT916106.....\$9.20	
-6	1/8	EARAT916162.....\$11.16	
-6	3/8	EARAT916166.....\$12.12	
-8	1/4	EARAT916107.....\$12.12	
-8	3/8	EARAT916108.....\$12.16	
-8	1/2	EARAT916188.....\$14.53	
-10	1/2	EARAT916110.....\$16.02	
-10	3/8	EARAT916111.....\$14.53	
-12	3/4	EARAT916112.....\$23.23	
-12	1/2	EARAT916113.....\$23.23	

90° Elbow

A	B		
-3	-3	EARAT982103.....\$16.44	
-4	-4	EARAT982104.....\$16.44	
-6	-6	EARAT982106.....\$16.44	
-8	-8	EARAT982108.....\$17.55	
-10	-10	EARAT982110.....\$19.79	
-12	-12	EARAT982112.....\$20.80	
-16	-16	EARAT982116.....\$29.61	

Special Purpose

AN Port Adapter

O'Ring Seal (Port End contoured for max. flow)

A	B	Part #	
-6	(AN 4) 7/16-20	EARAT985064.....\$8.39	
-6	(AN 5) 1/2-20	EARAT985065.....\$10.51	
-6	(AN 6) 9/16-18	EARAT985066.....\$8.39	
-6	(AN 8) 3/4-16	EARAT985068.....\$12.34	
-8	(AN 6) 9/16-18	EARAT985086.....\$12.39	
-8	(AN 8) 3/4-16	EARAT985008.....\$10.51	
-8	(AN 10) 7/8-14	EARAT985081.....\$13.67	
-10	(AN 8) 3/4-16	EARAT985009.....\$13.67	
-10	(AN 10) 7/8-14	EARAT985010.....\$13.67	
-10	(AN 12) 1 1/16-12	EARAT985011.....\$18.95	
-12	(AN 10) 7/8-14	EARAT985013.....\$18.95	
-12	(AN 12) 1 1/16-12	EARAT985012.....\$18.95	
-16	(AN 8) 1 1/16-12	EARAT985015.....\$26.32	
-16	(AN 16) 1 5/16-12	EARAT985016.....\$26.32	

AN Tee

Female Swivel on Side

A	B	C	Part #	
-3	-3	-3	EARAT925103.....\$26.32	
-4	-4	-4	EARAT925104.....\$26.32	
-6	-6	-6	EARAT925106.....\$21.19	
-8	-8	-8	EARAT925108.....\$31.61	
-10	-10	-10	EARAT925110.....\$35.82	
-12	-12	-12	EARAT925112.....\$44.08	

AN Tee

Female Swivel on Run

A	B	C	Part #	
-3	-3	-3	EARAT926103.....\$26.32	
-4	-4	-4	EARAT926104.....\$22.11	
-6	-6	-6	EARAT926106.....\$20.71	
-8	-8	-8	EARAT926108.....\$31.13	
-10	-10	-10	EARAT926110.....\$37.91	
-12	-12	-12	EARAT926112.....\$45.13	

45° Female

AN Swivel to Female AN Swivel - Tube

A	B	Part #	
-3	-3	EARAT939203.....\$16.10	
-4	-4	EARAT939204.....\$15.09	
-6	-6	EARAT939206.....\$15.09	
-8	-8	EARAT939208.....\$18.03	
-10	-10	EARAT939210.....\$24.27	
-12	-12	EARAT939212.....\$28.54	
-16	-16	EARAT939216.....\$33.95	

90° Female

AN Swivel to Female AN Swivel - Tube

A	B	Part #	
-3	-3	EARAT935103.....\$16.10	
-4	-4	EARAT935104.....\$15.31	
-6	-6	EARAT935106.....\$15.31	
-8	-8	EARAT935108.....\$18.29	
-10	-10	EARAT935110.....\$24.03	
-12	-12	EARAT935112.....\$28.54	
-16	-16	EARAT935116.....\$34.11	

90° Male

AN to Male Swivel NPT

A	B		
-3	1/8	EARAT922103.....\$24.88	
-4	1/8	EARAT922104.....\$21.05	
-4	1/4	EARAT922144.....\$20.71	
-6	1/4	EARAT922106.....\$21.05	
-6	1/8	EARAT922162.....\$22.05	
-6	3/8	EARAT922166.....\$24.22	
-8	1/4	EARAT922107.....\$24.22	
-8	3/8	EARAT922108.....\$24.22	
-8	1/2	EARAT922188.....\$27.38	
-10	1/2	EARAT922110.....\$31.61	
-10	3/8	EARAT922111.....\$35.29	
-12	3/4	EARAT922112.....\$41.56	
-12	1/2	EARAT922113.....\$41.56	

Special Purpose Adapters

(Female AN to male AN)

size		
-3	EARAT924103.....\$24.40	
-4	EARAT924104.....\$16.46	
-6	EARAT924106.....\$18.38	
-8	EARAT924108.....\$26.04	
-10	EARAT924110.....\$34.58	
-12	EARAT924112.....\$41.56	
size		
-3	EARAT921103.....\$24.40	
-4	EARAT921104.....\$16.07	
-6	EARAT921106.....\$16.59	
-8	EARAT921108.....\$22.11	
-10	EARAT921110.....\$26.32	
-12	EARAT921112.....\$31.61	



Econ-O-Fit

Hose Clamp Covers

ID	Hose ID	Red	Blue
1/2	7/32	EAR900104	...EAR900204...\$3.97
5/8	11/32	EAR900106	...EAR900206...\$3.97
11/16	7/16	EAR900108	...EAR900208...\$5.97
13/16	9/16	EAR900110	...EAR900210...\$5.97
15/16	11/16	EAR900112	...EAR900212...\$5.97

AN to AN Adapters

Female AN Tee ("O" Ring Seal)

A	B	C	Part #	Price
-4	-4	-4	EAR993804	...\$12.70
-6	-6	-6	EAR993806	...\$12.70
-8	-8	-8	EAR993808	...\$16.18
-10	-10	-10	EAR993810	...\$22.92
-12	-12	-12	EAR993812	...\$31.28

Adapter Fitting

straight female swivel	A/B	Part #	Price
-3/-3		EAR915103	...\$8.39
-4/-4		EAR915104	...\$7.41
-6/-6		EAR915106	...\$7.41
-8/-8		EAR915186	...\$8.91
-8/-8		EAR915108	...\$8.82
-10/-10		EAR915110	...\$11.16
-12/-12		EAR915112	...\$15.63
-16/-16		EAR915116	...\$21.21
-20/-20		EAR915120	...\$48.48

Tube Nut/Aluminum

AN size	Tube Size	Part #	Price
-3	3/16	EAR581803	...\$4.97
-4	1/4	EAR581804	...\$4.97
-6	3/8	EAR581806	...\$3.45
-8	1/2	EAR981808	...\$2.12
-10	5/8	EAR981810	...\$3.74

Tube Sleeve/Aluminum

AN size	Tube Size	Part #	Price
-3	3/16	EAR581903	...\$3.21
-4	1/4	EAR581904	...\$3.36
-6	3/8	EAR581906	...\$3.38
-8	1/2	EAR981908	...\$1.88
-10	5/8	EAR981910	...\$2.12

Tube Nut / Steel

AN size	Tube Size	Part #	Price
-3	3/16	EAR561803	...\$3.97
-4	1/4	EAR561804	...\$5.97
-6	3/8	EAR561806	...\$6.98 *2 per pkg

Tube Sleeve / Steel

AN size	Tube Size	Part #	Price
-3	3/16	EAR561903	...\$3.04
-4	1/4	EAR561904	...\$3.04
-6	3/8	EAR561906	...\$3.04

AN Plug / Aluminum

size	Qty.	Part #	Price
-3	2	EAR580603	...\$3.05
-4	2	EAR580604	...\$3.25
-6	2	EAR580606	...\$3.74
-8	1	EAR980608	...\$2.91
-10	1	EAR980610	...\$3.54
-12	1	EAR980612	...\$5.51
-16	1	EAR980616	...\$7.22
-20	1	EAR980620	...\$24.03



Aluminum Tubing Adapters

"A"	"B"	Part #	Price
-6 AN Male	5/16"	EAR165056	...\$11.21
-6 AN Male	1/4"	EAR165064	...\$12.24
-6 AN Male	3/8"	EAR165006	...\$11.21
-8 AN Male	3/8"	EAR165086	...\$13.26
-8 AN Male	1/2"	EAR165008	...\$13.26
-10 AN Male	1/2"	EAR165010	...\$15.75
-6 AN Female	5/16"	EAR165156	...\$11.21
-6 AN Female	3/8"	EAR165106	...\$12.24
-8 AN Female	1/2"	EAR165108	...\$13.60
-10 AN Female	5/8"	EAR165110	...\$18.63

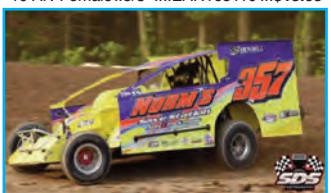

Pressure Gauge Adapter

Inline adapters for direct or remote fuel pressure gauges. All 1/8 NPT in hex.

-8 male w/ 1/4 NPT female	EAR100191	...\$23.54
-6 male to -6 male	EAR100192	...\$10.51
-6 male to 1/4 NPT	EAR100193	...\$11.02
-6 male to 3/8 NPT	EAR100194	...\$12.61
-6 male to -8 male	EAR100196	...\$13.13
-8 male to 1/4 NPT	EAR100197	...\$12.20
-8 male to 3/8 NPT	EAR100198	...\$12.87
-6 male to -6 female	EAR100199	...\$13.66
-8 male to -8 female	EAR100200	...\$16.78

Fuel Pressure Gauge

Direct mount 0-15 psi gauge is 1-1/2" dia. Both have 1/8 NPT on back.

Regular	EAR100195	...\$20.43
Liquid Filled	EAR100189	...\$31.60

Pressure Gauge Adapters

-3 Male with 1/8 NPT Female

EAR100188	...\$15.77
-----------	------------

Tee Adapter

-8 AN male tee w/4 AN on run • Hose End 8 Blue

EAR982484	...\$25.05	
Black	EAR982484	...\$21.05

Gauge Head Adapters

-4 Male -4 to female 1/8 NPT

90°	EAR968604	...\$5.17
Straight	EAR968704	...\$5.97

-3 Male -3 to female 1/8 NPT

90°	EAR968603	...\$7.07
Straight	EAR968703	...\$5.97

Oil Pressure Fittings

-3 St. to 1/8 NPT

EAR968803	...\$10.00
-----------	------------

-4 St. to 1/8 NPT

EAR968804	...\$10.00
-----------	------------

In-Line Filter

Barb 5/16"-3/8"

EAR230103	...\$37.84
-----------	------------

Element Only

EAR230107

EAR230107	...\$9.17
-----------	-----------

In-Line Filter

-6 35 Micron Fuel

EAR230106	...\$40.40	
-6 35 Micron Fuel	EAR230108	...\$40.71

-6 85 Micron Fuel

EAR230206	...\$37.22	
-6 85 Micron Fuel	EAR230208	...\$45.49

-6 140 Micron Fuel

EAR230306	...\$38.75	
-6 140 Micron Fuel	EAR230308	...\$48.73

Screen Type

In-Line Filters

-4 Oil	EAR230304	...\$34.77
-10 Oil	EAR230310	...\$46.01
-12 Oil	EAR230312	...\$51.22
-16 Oil	EAR230316	...\$64.16

Billet Fuel Filters

10 Micron -6 (100 GPH)

EAR230606	...\$68.56	
40 Micron -6 (100 GPH)	EAR230616	...\$68.56
100 Micron -6 (100 GPH)	EAR230626	...\$68.56

10 Micron -8 (175 GPH)

EAR230608	...\$79.83	
40 Micron -8 (175 GPH)	EAR230618	...\$79.83
100 Micron -8 (175 GPH)	EAR230628	...\$79.83

Check Valves

Reinforced Viton with Alum Support 150 PSI Max

5 PSI to seal (One Way or Non-Return Valves)		
-4	EAR251004	...\$71.64
-6	EAR251006	...\$71.64
-8	EAR251008	...\$71.64
-10	EAR251010	...\$87.00

Compression Sleeves

1/4"

EAR165040	...\$2.96	
5/16"	EAR165050	...\$2.96
3/8"	EAR165060	...\$2.96
1/2"	EAR165080	...\$3.97
5/8"	EAR165100	...\$3.97

AN Union / Steel

AN size	Tube Size	Part #	Price
-3	3/16	EAR961503	...\$5.75
-4	1/4	EAR961504	...\$3.42

Fuel Shut-Off Valve

Inlet	Outlet	Part #	Price
3/8 NPT	-6	EAR230502	...\$39.49
3/8 NPT	-8	EAR230503	...\$38.73
1/2 NPT	-10	EAR230505	...\$54.56
1/2 NPT	-6	EAR230501	...\$37.93
1/2 NPT	-8	EAR230504	...\$42.14

B-Nut Fuel Line Kits

Single Inlet Ano-Tuff SS Hose

-6 AN	EARAT101185	...\$100.95
-8 AN	EARAT101285	...\$115.95

Single Inlet Ano-Tuff Pro-Lite 350 Hose

-6 AN	EARAT101195	...\$100.95
-8 AN	EARAT101295	...\$115.95

Single Inlet Billet Swivel Seal Stainless Steel Fuel Line

-6 AN	EARAT101175	...\$94.62
-8 AN	EARAT101275	...\$114.95

Single Inlet B-Nut Disassembly Swivel Seal Pro Lite 350

-6 AN	HOL34-42	...\$112.95
-------	----------	-------------

Single Inlet B-Nut Disassembly Swivel Seal Pro Lite 350

-6 AN	EARAT104195	...\$99.47
-8 AN	EARAT104295	...\$114.95

Dual Inlet B-Nut Disassembly Swivel Seal Pro Lite 350

-6 AN	EARAT102196	...\$112.95
-8 AN	EARAT102296	...\$141.95

Dual Inlet Ano-Tuff Stainless Steel Hose

-6 AN	EARAT102196	...\$112.95
-8 AN	EARAT102296	...\$141.95

Billet Style Fits 4150 series.

Single Inlet Swivel Seal w/ 9-1/2" spacing.

-8 AN male inlet.		
Single Inlet	EAR101275	...\$114.95
Dual Inlet	EAR101276	...\$138.95

Fits 4500 series. Single Inlet Swivel Seal w/12" spacing.

-8 AN male inlet.		
Single Inlet	EAR102275	...\$118.95

Dual Inlet B-Nut Disassembly Swivel Seal Fuel Line

-6 AN	EARAT102186	...\$112.95
-------	-------------	-------------

Billet Fuel Line Kit Swivel Seal -8AN male on both ends

4500 Model Dominators w/875 - 20 Threads		
-8 AN	EAR102276	...\$142.95

3/8 Female Inlet Push-On 90° Tube 7/8-20

EARAT105175	...\$62.93
-------------	------------

Fuel Line Replacement Hose End, Fits -8 Hose, 7/8"-20 End Fits Carb,

EAR103176	...\$99.05
-----------	------------

Fuel Line Kits

Dual feed fuel line kits include the correct fittings and hoses to properly plumb single carburetor applications when connecting to AN style fitting.

Red/Blue Holley (4150 Series)

-6 Line, 9-5/16" Center Distance	ALL26154	...\$64.99
-8 Line, 9-5/16" Center Distance	ALL26156	...\$64.99

Black Holley (4150 Series)

-6 Line, 9-5/16" Center Distance	ALL26164	...\$64.99
-8 Line, 9-5/8" Center Distance	ALL26165	...\$64.99
-8 Line, 9-5/16" Center Distance	ALL26166	...\$64.99

Aluminum Weld Fittings

Female AN (o-ring seal)

-4	EAR987104	...\$7.99
-6	EAR987106	...\$7.99
-8	EAR987108	...\$7.99
-10	EAR987110	...\$11.06
-12	EAR987112	...\$14.78
-16	EAR987116	...\$18.70

Female NPT

1/8"	EAR996701	...\$4.16
1/4"	EAR996702	...\$4.72
3/8"	EAR996703	...\$6.62
1/2"	EAR996704	...\$7.52
3/4"	EAR996706	...\$10.17

Aluminum Weld Fittings Male AN



Hose 910

GOODRIDGE

The Hose 910 is the #1 choice of leading motorsport teams, and our flagship lightweight hose. 910 combines a woven superlight Aramid braid, with a PTFE inner bore- smooth inside for increased flow and convoluted outside for amazing flexibility. Compatible with fully crimped fittings or the revolutionary 811 series. Re-useable fittings.

Application: Fuel, Oil, Water, Methanol, Air

Temp Range: -70°C to 260°C

-94°F to 500°F

Material: Anti-Static PTFE smoothbore, Aramid fibre Braid

**NHRA PSI
Testing Available**

Bore Size MM IN	Braid OD MM IN	Working Pres MM IN	Burst Pres BAR PSI	Weight KG/M LB/FT	Min Bend Rad MM IN
6.85 .270 GOO910-04	10.3 .406 \$14.38	90 1320	360 5290	.055 .0367	23.5 .925
9.53 .375 GOO910-06	13.0 .572 \$17.81	80 1180	320 4700	.088 .0591	20 .787
12.70 .500 GOO910-08	16.5 .650 \$24.20	70 1030	280 4120	.141 .0947	38 1.426
15.88 .625 GOO910-10	20.8 .819 \$31.13	65 955	260 3820	.201 .1351	45 1.772
19.05 .750 GOO910-12	24.4 .961 \$39.23	60 880	240 3530	.292 .1962	50 1.969
25.40 1.000 GOO910-16	32.3 1.272 \$59.93	50 740	200 2940	.416 .3199	70 2.756
32.00 1.260 GOO910-20	38.4 1.512 \$103.40	45 666	180 2645	.850 .6536	100 3.937

Crimp Collar

G-Line XF 910/811

G-Flex 511/ 711 & G-Max 825



Alum Crimp Collar to Suit 811 & 910 Hose for Crimping

To Suit Hose Type: G-Line XF 910, 811

Please Note: Collars need to be ordered separately for all swage/crimp fittings

Hose

-6	GOORCC711-06D	\$7.01
-8	GOORCC711-08D	\$7.64
-10	GOORCC711-10D	\$8.27
-12	GOORCC711-12D	\$8.81
-16	GOORCC711-16D	\$10.79

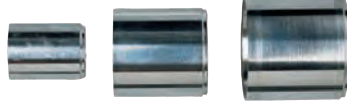

811 Hose Ends

They are designed for maximum ease of use, and optimum performance under pressure and temperature on the Goodridge 811, and 910. The sleek black and silver hard anodized aluminum color scheme will add class to any installation.



811-01 15° Straight Female

Hose	Nut	Part #	Price
-4	-4	GOO811-0104	\$16.09
-6	-6	GOO811-0106	\$16.09
-8	-8	GOO811-0108	\$22.39
-10	-10	GOO811-0110	\$25.09
-12	-12	GOO811-0112	\$26.89
-16	-16	GOO811-0116	\$40.04

812-45 45° Forged Female

-6	-6	GOO812-4506	\$27.97
-8	-8	GOO812-4508	\$32.57
-10	-10	GOO812-4510	\$40.32
-12	-12	GOO812-4512	\$53.09

811-45 45° Swept Tube Female

-4	-4	GOO811-4504	\$26.99
-6	-6	GOO811-4506	\$22.36
-8	-8	GOO811-4508	\$27.24
-10	-10	GOO811-4510	\$33.04
-12	-12	GOO811-4512	\$44.61
-16	-16	GOO811-4516	\$48.32

811-30 30° Swept Tube Female

-10	-10	GOO811-3010	\$67.79
-----	-----	-------------	----------------

812-90 90° Forged Female

-6	-6	GOO812-9006	\$27.97
-8	-8	GOO812-9008	\$32.57
-10	-10	GOO812-9010	\$40.32
-12	-12	GOO812-9012	\$53.09

811-90 90° Swept Female

-4	-4	GOO811-9004	\$26.99
-6	-6	GOO811-9006	\$22.36
-8	-8	GOO811-9008	\$27.24
-10	-10	GOO811-9010	\$33.04
-12	-12	GOO811-9012	\$44.61
-16	-16	GOO811-9016	\$48.32
-20	-20	GOO811-9020	Scall

811-120 120° Swept Tube Female

-4	-4	GOO811-12004	\$29.94
-6	-6	GOO811-12006	\$27.33
-8	-8	GOO811-12008	\$32.62
-10	-10	GOO811-12010	\$36.14
-12	-12	GOO811-12012	\$44.36
-16	-16	GOO811-12016	\$79.60
-20	-20	GOO811-12020	Scall

811-150 150° Swept Tube Female

-4	-4	GOO811-15004	\$29.94
-6	-6	GOO811-15006	\$27.33
-8	-8	GOO811-15008	\$32.62
-10	-10	GOO811-15010	\$36.14
-12	-12	GOO811-15012	\$44.36
-16	-16	GOO811-15016	\$79.60
-20	-20	GOO811-15020	Scall

811-180 180° Swept Tube Female

-4	-4	GOO811-18004	\$29.94
-6	-6	GOO811-18006	\$27.33
-8	-8	GOO811-18008	\$32.62
-10	-10	GOO811-18010	\$36.14
-12	-12	GOO811-18012	\$44.36
-16	-16	GOO811-18016	\$79.60



Holley Carb Adapter

-08 Female x 7/8-20"
GOOHOLCAB-08DBW.....**\$26.32**



Aluminum Crush Washer

GOOCW901-10.....**\$0.53**



**SUPER LIGHTWEIGHT!
CUSTOM LENGTHS AVAILABLE!**

711-01 Straight Female

To Suit	Thread	Part #	Price
511/711/825/910	-06	9/16 x 18	GOO711-0106 \$12.88
511/711/825/910	-08	3/4 x 16	GOO711-0108 \$16.68
511/711/825/910	-10	7/8 x 14	GOO711-0110 \$20.02
511/711/825/910	-12	1-1/16 x 12	GOO711-0112 \$26.22
511/711/825/910	-16	1-5/16 x 12	GOO711-0116 \$32.90



711-45 45° Female Tube Fitting

To Suit	Thread	Part #	Price
511/711/825/910	-06	9/16 x 18	GOO711-4606 \$27.80
511/711/825/910	-08	3/4 x 16	GOO711-4608 \$33.36
511/711/825/910	-10	7/8 x 14	GOO711-4610 \$39.85
511/711/825/910	-12	1-1/16 x 12	GOO711-4612 \$46.34
511/711/825/910	-16	1-5/16 x 12	GOO711-4616 \$63.03



711-60 60° Female Tube Fitting

To Suit	Thread	Part #	Price
511/711/825/910	-8	3/4 x 16	GOO711-6012 \$47.74
511/711/825/910	-10	7/8 x 14	GOO711-6012 \$47.74
511/711/825/910	-12	1-1/16 x 12	GOO711-6012 \$47.74
511/711/825/910	-16	1-5/16 x 12	GOO711-6012 \$47.74



711-91 90° Female Tube Fitting

To Suit	Thread	Part #	Price
511/711/825/910	-06	9/16 x 18	GOO711-9106 \$27.80
511/711/825/910	-08	3/4 x 16	GOO711-9108 \$33.36
511/711/825/910	-10	7/8 x 14	GOO711-9110 \$39.85
511/711/825/910	-12	1-1/16 x 12	GOO711-9112 \$46.34
511/711/825/910	-16	1-5/16 x 12	GOO711-9116 \$63.03



711-120 120° Female Tube Fitting

To Suit	Thread	Part #	Price
511/711/825/910	-06	9/16 x 18	GOO711-12006 \$53.99
511/711/825/910	-08	3/4 x 16	GOO711-12008 \$57.59
511/711/825/910	-10	7/8 x 14	GOO711-12010 \$62.99
511/711/825/910	-12	1-1/16 x 12	GOO711-12012 \$65.69
511/711/825/910	-16	1-5/16 x 12	GOO711-12016 \$59.43



711-150 150° Female Tube Fitting

To Suit	Thread	Part #	Price
511/711/825/910	-06	9/16 x 18	GOO711-15006 \$27.05
511/711/825/910	-08	3/4 x 16	GOO711-15008 \$43.16
511/711/825/910	-10	7/8 x 14	GOO711-15010 \$49.00
511/711/825/910	-12	1-1/16 x 12	GOO711-15012 \$50.37
511/711/825/910	-16	1-5/16 x 12	GOO711-15016 \$59.43

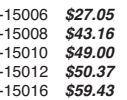

711-180 180° Female Tube Fitting

To Suit	Thread	Part #	Price
511/711/825/910	-06	9/16 x 18	GOO711-18006 \$40.50
511/711/825/910	-08	3/4 x 16	GOO711-18008 Scall
511/711/825/910	-10	7/8 x 14	GOO711-18010 Scall
511/711/825/910	-12	1-1/16 x 12	GOO711-18012 Scall
511/711/825/910	-16	1-5/16 x 12	GOO711-18016 \$55.29



Mini Breather Tank



Tank is complete with 1/4" NPT bung at bottom and bkt for mounting to chassis tubing.

Breather Tank 1.50" Mt. ALL36140...\$49.99
Breather Tank 1.75" Mt. ALL36141...\$49.99
Replacement Element...ALL36103...\$12.99

1 Pint Mini Breather

1/4" fittings...JAZ605-325-01...\$69.85
3/8" fittings...JAZ605-375-01...\$70.65

1 Quart Breather Tanks

1 quart tank includes breather and drain.
AN -6.....JAZ605-025-01.....\$52.27
AN -8.....JAZ605-825-01.....\$53.73
AN -10.....JAZ605-125-01.....\$59.41
AN -12.....JAZ605-225-01.....\$69.85



6" DIRT Modified Oil Tank

22" x 6" • -16 inlet -12 outlet
PET08-0837DM.....\$877.02

Remote Breather Cans

Spun Alum., complete w/2 each -12AN female ports and -6 drain plug. Use oil tank fittings for hose attachment.
PET08-0400.....\$174.78

3" dia with 1 each -12AN male fitting for oil tank breather & 1 each -8AN male fitting to breath rear end. Complete w/quick drain valve & mounting clamp. Internally baffled.
PET08-0410.....\$157.31



Self Vented Round Dirt Modified LR Oil Tank (cleanable)

ART500102...\$415.95

Self Vented Round Dirt Modified LR Oil Tank (Two Piece)

ART500103...\$694.98

2 Piece Round Oil Tank with Tapered Bottom for Rear End Clearance on a Coil Car

ART500103C...\$694.98

BRP Rear Oil Tank Mount

ART500105...\$180.78

Dry Sump Tank Bkt for BRP Car Left Rear Corner Mount

ART500106...\$121.80



Dry Sump Oil Tank Side Mt

Fits Bicknell and Teo Race Cars. Built with Oil Filter. Also comes with Heat Shield.
ART500101NJ.....\$685.00

Replacement Oberg 6020

6" 115 Micro Filter Screen
Fits Art's Side Mount Oil Tank
ART0B6020...\$59.95

HTD Belts 30mm wide

They are 8mm pitch and provide positive trouble free power transmission for pump drives. They are suitable for high torque ranges previously serviced by chain or gear drive systems.
632mm HTD Belt...PET05-1904...\$24.74
640mm HTD Belt...PET05-1935...\$35.88
720mm HTD Belt...PET05-1906...\$26.93

Gilmer Belts

24.0" ...GIL24.OL100...\$19.95
25.5" ...GIL25.5L100...\$20.95
27.0" ...GIL27.OL100...\$20.95

Dirt Late Model Center Vent Tank

This tank features a built in oil filter with 60 or 75 micron stainless pleated element.

Vertical Filter Box

-16 AN Return -16 AN Pickup
3 Gallon Tank
Single Return w/Filter
PET08-0911-DB...\$1113.56

Lay Down Filter Box

-16 AN Return -16 AN Pickup
3 Gallon Tank
Single Return w/Filter
PET08-0911-CJR...\$1131.54

Oil Tank Mount Brackets 6" & 9" Tanks

6" dia. tank.....PET08-0100.....\$72.90
9" dia. tank.....PET08-0101.....\$70.77

External Heating Pad

5" x 7", self-adhesive. 400 Watts (min). Heats oil from 66°F to 160°F in only 25 minutes. 36" 110V cord
MOR23996.....\$63.08
2" x 15", self-adhesive. 150 Watts. Perfect for slender areas of oil pans/dry sump tanks. 36" 110V cord
MOR23997.....\$78.13

Oil Tank Heaters

300 WATT immersion style heater. 110 Volt with detachable cord set. Comes complete with both steel and aluminum 1/2" NPT weld bung.
PET08-0300.....\$128.89

400 Series Oil Filters

The filter has 25% more filter area than similar filters and is available in 60 microns, 75 microns and 100 microns screen sizes for engine oil. Filter bodies are anodized for durability. Mount bracket sold separately.

60 Micron Element w/Bypass	Without Bypass
-8AN...PET09-0450...\$152.03	PET09-0456...\$136.28
-10AN...PET09-0451...\$152.03	PET09-0457...\$136.28
-12AN...PET09-0452...\$152.03	PET09-0458...\$136.28
-16AN...PET09-0453...\$152.03	PET09-0459...\$136.28

75 Micron Element w/Bypass	Without Bypass
-8AN...PET09-0430...\$152.03	PET09-0436...\$136.28
-10AN...PET09-0431...\$152.03	PET09-0437...\$136.28
-12AN...PET09-0432...\$152.03	PET09-0438...\$136.28
-16AN...PET09-0433...\$152.03	PET09-0439...\$136.28
-20AN...PET09-0426...\$152.03	PET09-0425...\$136.28

100 Micron Element w/Bypass	Without Bypass
-8AN...PET09-1430...\$155.89	PET09-1436...\$140.15
-10AN...PET09-1431...\$155.89	PET09-1437...\$140.15
-12AN...PET09-1432...\$155.89	PET09-1438...\$140.15
-16AN...PET09-1433...\$155.89	PET09-1439...\$140.15
-20AN...PET09-1426...\$152.03	PET09-1425...\$136.28

400 Series Oil Filter Replacement Parts

100 Micron, -20 filter element Silver/Purple end cap
Without Bypass.....PET09-0414...\$48.11
With Bypass.....PET09-0415...\$69.10

75 Micron, -20 filter element Silver/Blue end cap
Without Bypass.....PET09-0418...\$48.11
With Bypass.....PET09-0419...\$69.10

75 Micron, -8, -10, -12, -16 filter element Gold/Blue end cap
Without Bypass.....PET09-0440...\$48.11
With Bypass.....PET09-0441...\$69.10

60 Micron, -8, -10, -12, -16 filter element Gold/Black end cap
Without Bypass.....PET09-0460...\$48.11
With Bypass.....PET09-0461...\$72.95

100 Micron, -8, -10, -12, -16 filter element Gold/Purple end cap
Without Bypass.....PET09-1440...\$52.06
With Bypass.....PET09-1441...\$73.04

Vacuum Regulator

Adjustable vacuum regulator holds a steady level of crankcase vacuum and can be regulated from as high as 29.7 in/hg down to 2 in.hg.
PET08-0455...\$164.79

Screw-In Breathers

-12 AN male threaded breather screws into the supplied bung which can be welded to your aluminum valve cover or dry sump tank.
Screw-In Breather.....PET08-0415...\$57.21

Same but built-in one way valve. Keep crankcase in constant vacuum. Stops air from entering engine but opens to relieve pressure.
With one way valve...PET08-0450...\$88.78

Sprint Car Tank Bkt 6" dia

It bolts directly to the front of a SBC engine. This bkt is fabricated from aircraft quality alum & uses stainless straps for durability.
PET08-0105...\$72.96

One Piece Oil Pan Gasket

SBC V8 '75-'79 thick front seal. Side rails trimmed for strokers.

Left Hand Dipstick.....FEL1880...\$37.42
Right Hand Dipstick...FEL1881...\$38.81
Straight Rail.....FEL1882...\$37.42

BBC V8 Thick 3/32" Molded rubber, 1 piece w/rigid carrier
FEL1884R...\$35.43



Oil Accumulators

3 qts of oil under pressure provide emergency supply when needed. Air Pressure gauge verifies that. Accumulator is ready for use. Cold start valve releases oil into cold engine for reduced wear. Tapped 1/2" NPT fitting.

3 qt cap, 20-1/8" x 4-1/4" cyl...MOR23900...\$227.64
1.5 qt cap, 10" x 4-1/4" cyl...MOR23901...\$220.65

Accumulator Mount

Designed to be easily fastened to any flat surface. Includes T-Bolt type clamps for NHRA.
MOR23920...\$30.24

Oil Check Valve, One Way

1/2" NPT to 1/2" NPT One Way. For use with oil accumulators & oil coolers. For prevention of oil drain-back
MOR23875...\$27.63

Oil Preheaters

212 watts of power raises temp of 12 qts. of oil 60°F in about 30 mins. 1" NPT fitting 120 volt rating; includes detachable 7-ft cord. Length of heating element is 4-1/2" from fitting to tip.

Internal, Aluminum fitting.....MOR23980...\$87.97
Internal, Steel fitting.....MOR23990...\$87.97

Replacement Parts:

Electric Cord.....MOR97590...\$18.13

Engine Oil Dipstick & Tube - BBC 1965-'90

Fits BBC 1965-'90 w/ Oil Pan Mounted Dipstick. Dress up your engine with a chrome plated dipstick and tube. Similar to OEM units, only simple hand tools are required for installation.
MRG6236...\$14.38

Universal Dipstick Kit

Chrome plated Dipstick Kit fits oil pans with a built-in 1/4" NPT fitting. Overall length of dipstick - 24".
MOR25970.....\$18.97



Louvered Windage Trays Chevy V8 Oil Pans

It allows oil thrown from rotating assembly to drain into sump without splashing back. Teflon coated for quick drainage. Improved drainage reduces windage, increases power. Mt with aftermarket stud kits or with stock extended main cap studs. Either driver or passenger side dipstick
SBC and 400 Block...MOR23020...\$35.13
BBC.....MOR23030...\$35.13

Universal Windage Tray Screen

23" x 16". Keeps rotating assembly free of unwanted oil to reduce hp robbing windage. Screen must be trimmed for each application.
MOR22912...\$44.37

Crankshaft Wipers

Removes excess oil from crankshaft to reduce horsepower-robbing windage. .035" steel plate comes pre-fitted so only slight amounts of material must be removed. Trim to within .045" of the connecting rods and counterweights for best results.
SBC.....MOR25800...\$13.91
BBC.....MOR25830...\$13.91

Oil Pan Inspect Plug Kit

Includes steel fitting to be welded to side of oil pan and removable LW 1" NPT alum inspection plug.
MOR23970...\$14.32

Drain Plug Washers

10 per pack. Dead-soft copper.
1/2" i.d. x 7/8" o.d.
MOR97010...\$7.30

Oil Pan Drain Plug

Chrome-Plated. Nylon Washer. 3/4" hex head with 1/2" x 20 threads.
MOR7000...\$7.92

Wet Sump 7 Qt, 9-1/2" Deep

Most Chassis (except '62-67 Chevy II, V8 Vega and Monza) Accepts up to 3.800" stroke with steel rods. Trap door baffle for improved oil control. Reduces oil temp. treat Perf, Deep Sump Engine App: '80-85 blocks with passenger-side dipstick. MOR20165....\$196.25



Wet Sump, 7 Qt, 8-1/4" Deep

Pre-'80 with driver-side dipstick. Accepts 3.80" stroke with most steel rods. Kicked-out sump. Crank scraper welded to pan. Uni-directional windage tray screen. Trap door baffle for improved oil control. MOR20191....\$269.95

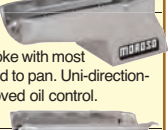

Wet Sump, 7 Qt, 7-1/8" Deep

GM Metric A-Body chassis, Street Stock & Late Model. 5 trap door baffles for oil control. Accepts 3.80" stroke w/steel rods. Kicked Out Sump. App: Pre-'80 Blocks w/driver-side Dipstick or '80-85 Blocks w/passenger-side Dipstick. MOR21312....\$380.87

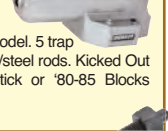

Valve Cover Stud Kits

ARP
Cast Alum Covers Black Oxide Stud Kits Size: 1/4-20
Stud OAL/Bolt UHL: 1.500
8 Qty....ARP200-7603..\$19.17 14 Qty..ARP200-7604...\$33.49
Dart, Brodix, B&B Size: 1/4-20 • Stud OAL/Bolt UHL: 3.500
14 Qty..ARP200-7607..\$55.11 16 Qty..ARP200-7608...\$62.97
Stamped Steel Covers Black Oxide Stud Kits Size: 1/4-20
Stud OAL/Bolt UHL: 1.170
8 Qty....ARP200-7601..\$18.39 14 Qty..ARP200-7602...\$32.17



Valve Cover Gasket Performance

262-400 SBC Gen I 1955-86
Cork/Rubber, SBC, Pair. Extra Thick 5/16"
MRG179.....\$26.57



Oil Pan Stud and Bolt Kit

Easily align gasket and pan for a leakproof installation.
Hex Head 12 Point
SBC Pan Studs.....ARP234-1901..\$51.93
SBC Pan Bolts.....ARP234-1802..\$26.19.....ARP234-1801...\$27.07

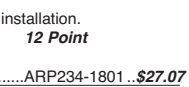

Steel Valve Covers

SBC steel valve covers are sold in pairs. 1 cover has two 1-1/2" baffled breather tubes and both covers feature reinforced rails. Clamp-on breathers sold separately.
SBC Valve Cover (Black), Pressed In Tubes
ALL26147.....\$31.99



SBC Die Cast Aluminum, Tall Design w/ Welded Breather Tubes

Hooded breathers & studs included. Filtered Breather Valve Cov Set. 2 breather tubes welded to 1 cover.
With Moroso Logo.....MOR68370...\$195.52
Without Moroso Logo.....MOR68374...\$197.55



SBC Fabricated Aluminum, Billet Rail, 3" Tall Design

Fab entirely from superior quality alum. 1-piece billet rail is CNC machined from 6061-T6 alum to ensure a precision flat surface for superior sealing. Fits Sprint Car style Brodix-12 and stock style SBC cyl heads
MOR68338.....\$404.88

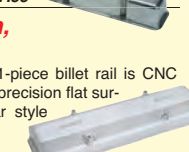

BBC Die Cast Alum, Tall Design

2 breather/filler cap grommets and 1 baffled and 1 non-baffled PCV grommet.
Without Moroso logo.....MOR68425...\$194.64



Fabricated Aluminum, Billet Rail, Swept Back Design

It engineered to clear most marine wet manifolds. Designed to clear chassis on Dirt Mods. Billet Rail with steel inserts.
MOR68350.....\$507.03

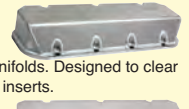

Fabricated Alum, Billet Rail

3" Tall for greater hood clearance. 1-piece billet rail is CNC machined to ensure a precision flat surface for superior sealing.
MOR68457.....\$420.82

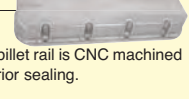

Crankcase Vent Kits

Complete with tubes and filters.
Weld-on...MOR68800....\$54.06 pr.
Push-in...MOR68810....\$48.61 pr.



Perm-Align V/C Gaskets 2 per pkg.

Superior quality silicone/steel gaskets outlast cork & rubber composite designs to provide years of dependable service, especially when constantly removing & reinstalling valve covers. Oil Resistant. Full 3/16" thick.
SBC...MOR93020...\$38.53
BBC...MOR93040...\$62.16

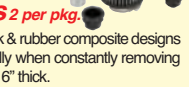

Valve Cover Gaskets

Cork gaskets w/steel core.
SBC, 5/16".....FEL1604...\$34.88
SBC, 1/4" 18" & Brodix...FEL1644...\$43.72
BBC, 5/16".....FEL1630...\$39.08
SBF, 3/16".....FEL1613...\$15.97
SBF, 5/16".....FEL1645...\$37.05



Oil Bypass Eliminator Chevy

Designed to eliminate the oil bypass found on Chevy engines. A stock type spin-on oil filter can be used with this part installed.
MOR23775....\$36.11



Billet Oil Bypass Adapters

Drilled & tapped for -10 AN fitting. Includes all hardware. Use with remote filter Bypass Plate SBC and BBC without hole in center of pad.
MOR23782....\$68.34



Oil Filter Adapters

Sandwich Adapter allows use with external plumbing, (coolers, dry sump pump or accumulator) while keeping filter in stock location. For use w/ext. pump or accumulator..MOR23690...\$91.78
For use w/remote coolers.....MOR23692...\$91.78



Oil Filter Adapter

SBC & BBC Style Engine Blocks with a Deep Oil Filter Pocket. Marked -10 AN "In" and "Out" ports make it easier to plumb a oil cooler. Adapter is taller than previous designs, lowers filter 2-1/2" to provide clearance for in and out oil lines.
MOR23691.....\$101.89



Oil Filter By-Pass Plate

SBC & BBC (Mark IV) Alum Bypass replaces engine mounted oil filter in wet sump oiling system and directs oil to remote oil filter or oil cooler. Drilled and tapped for 1/2" NPT inlet & outlet fittings.
MOR23770.....\$30.81

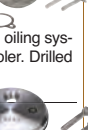

Oil Filter Alum Block-Off Plates SBC & BBC

Drilled & tapped to accept 1/2" NPT fitting to provide increased clearance for installing input pressure line. Plate Fits: SB & BB (exc. Gen V and Gen VI) Chevy applications without bolt hole at center of pad.
MOR23840.....\$36.05

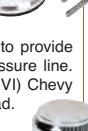

Valve Cover Filtered Breathers

Provides max protection against dirt and airborne debris without restricting air flow. Cleanable and reusable; oil before use.



1/2-Hood (180°) Clamp-On type welded-in stacks,

1-3/8" i.d.MOR68811....\$17.66
1-1/2" i.d.MOR68812...\$17.66
Push-In type w/punched holes...MOR68813...\$17.66
Non-Hooded Clamp-On type w/welded-in stacks
1-3/8" i.d.MOR68815...\$15.52
1-1/2" i.d.MOR68816...\$19.04
Push-In type w/punched holes.MOR68817...\$15.36
Not legal for sale or use on pollution-controlled vehicles

Oil Separators/Breathers

Push in fit for 1.22" hole
Gold Iridite.....MOR68780...\$10.72
Chrome Plate...MOR68781...\$11.23



Peterson

5 Stage R4 Std Dry Sump Pump

Left Side - Standard 1.200" Scavenge Rotors
Single Ret, Std Press.....PET04-5000...\$153.05
Dual Ret, Std Press.....PET04-5001...\$1525.38
Single Ret, HV Press.....PET04-5002...\$1531.56
Dual Ret, HV Press.....PET04-5003...\$1543.88
Single Ret, Std Press, RD.....PET04-5004...\$1568.56
Dual Ret, Std Press, RD.....PET04-5005...\$1580.91
Single Ret, HV Press, RD.....PET04-5006...\$1587.07
Dual Ret, HV Press, RD.....PET04-5007...\$1599.41



Right Side - Standard 1.200" Scavenge Rotors

Single Ret, Std Press.....PET04-5020...\$1513.05
Dual Ret, Std Press.....PET04-5021...\$1525.38
Single Ret, HV Press.....PET04-5022...\$1531.56
Dual Ret, HV Press.....PET04-5023...\$1543.88
Single Ret, Std Press, RD.....PET04-5024...\$1568.56
Dual Ret, Std Press, RD.....PET04-5025...\$1580.91
Single Ret, HV Press, RD.....PET04-5026...\$1587.07
Dual Ret, HV Press, RD.....PET04-5027...\$1599.41

5 Stage R4 Bellhousing Dry Sump Pump

Single Ret, HV Press, RD.....PET04-5056...\$1587.07

Rubber Valve Cov Gaskets

Silicone Molded Rubber w/Steel Core, Steel Compression Limiters. 2 per pack.
SBC V8 - 283, 302, 305, 327, 350, 400 Eng
.250 Thickness (Most Cylinder Heads)
FEL1628.....\$53.95



BBC V8 - 396, 402, 427, 454 Engines

.137 Thick (3 Up Bolt Holes & 4 Low Bolt Holes)
FEL1635.....\$42.93

Oil Cooler/Filter Sandwich Adapter

Mounts between spin-on oil filter & filter pad on engine block. Provisions for 10AN in & out lines to plumb remotely mounted oil accessories such as oil cooler or accumulator.
2-5/8" O'ring.
3/4"-16 thr. Ford, Chrysler, 4 & 6 cyl. apps.
MOR23693...\$76.47



13/16"-16 thr. Chevy, LS1 through '06 SB.
MOR23694...\$76.10

18mm-1.5 thr. Chevy, LT1 & GM 4 & 6 cyl. apps.
MOR23695...\$76.84

22mm-1.5 thr. New Ford, GM LS
MOR23699...\$81.13

Oil Pump Drives

SBC.....MAN42328....\$16.25
BBC.....MAN42329....\$14.77



Oil Pump Drive Shafts

SBC.....MOR22070.....\$17.58
BBC.....MOR22080.....\$16.33

Anti-Cavitation

SBC Oil Pumps
Std. Vol..MOR22101...\$105.28
High Vol..MOR22111...\$114.87



BBC Oil Pump

Std. Vol..MOR22150...\$90.82
High Vol..MOR22160...\$110.11

Heavy Duty Racing SBC Oil Pumps, 5/8" Inlet

Std. Vol..MOR22099...\$88.21
High Vol..MOR22109...\$106.43



BBC Oil Pump, 5/8" Inlet

Std. Vol..MOR22149...\$101.30
High Vol..MOR22159...\$102.33



EARL'S

Oil Filter Mount

13/16-16 center thread fits Fram HP-2 or equivalent, 1/2" NPT female ports.
EAR2477...\$31.94



Oil Filter Bypass

Fits 3/4-16 with spin on filter threads. 1/2 NPT female ports.
EAR1178...\$48.65



MOROSO

Breather Baffle

Bolts inside valve cover to keep oil from getting into breather.
MOR68790...\$5.69



PCV Grommets

Fits 1.22" holes, most GM PCV valves.
MOR68770...\$4.52



Breather Grommet Baffle

Fits 1.22" holes. 2 per pack.
MOR68775...\$4.96



Valve Cover Stud Kit

Include 8 studs, washers, & nylocks.
Slotted...MOR68820...\$9.90
Bullet Nose to help start nuts
MOR68830...\$22.00



Extra Long Wing Nuts

(w/ 1/4 x 20 studs)
Chrome steel...MOR68610...\$17.64

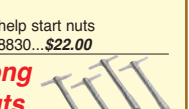

Hold Down Tabs (steel)

SBC
Chrome.....MOR68510...\$12.85
Red.....MOR68505...\$17.48
Blue.....MOR68506...\$17.48





Oil Coolers

15" x 8-3/4" x 3-1/4"

- (2) AN #12
- (1) 1/2" NPT
- #10AN Wash DP

BSC500-30145...\$235.00

15" x 6-1/2" x 3-1/4"

- (2) AN #12
- (1) 1/2" NPT
- #10 AN Wash DP

BSC500-30417...\$235.00

15" x 6-1/2" x 3-1/4"

- (2) AN #12
- (2) 1/2" NPT
- #10 AN Wash DP

BSC500-30416...\$239.00

15" x 4" x 3-1/4"

- (2) AN #10
- (1) 1/2" NPT
- #10 AN Wash DP

BSC500-30146...\$235.00

Oil Coolers

- 1/2" NPT Port
- 9" Face Width x 13" Body Width x 2" Thickness

- 10 Row...Height: 3".....BSC500-610-7612...\$112.33
- 13 Row...Height: 4".....BSC500-613-7612...\$114.93
- 16 Row...Height: 5".....BSC500-616-7612...\$126.71
- 19 Row...Height: 5-7/8".....BSC500-619-7612...\$135.37
- 25 Row...Height: 7-3/4".....BSC500-625-7612...\$140.81
- 34 Row...Height: 10-1/2".....BSC500-634-7612...\$175.33

*Use Earl's #10 AN Port Adapter (sold separately)



AN Port Adapter*

(*"O" Ring Seal)
(Port End contoured for max. flow)

- | A | B | Part # | |
|-----|----------------|-----------|----------|
| -8 | (AN 10) 7/8-14 | EAR985081 | \$.13.67 |
| -10 | (AN 10) 7/8-14 | EAR985010 | \$.13.20 |
| -12 | (AN 10) 7/8-14 | EAR985013 | \$.17.89 |

Linear Engine Oil Coolers



Finned aluminum coolers use 3/4" NPT ends. T-slot for easy mounting.

- 3' Inline Alum Oil Cooler.....ALL30142.....\$39.99
- 4' Inline Alum Oil Cooler.....ALL30143.....\$47.99
- 5' Inline Alum Oil Cooler.....ALL30144.....\$55.99



In-Line Oil Cooler

It can cool trans or power steering fluid by as much as 30°. Easily mounts with two 1/4" bolts or tie wraps. Suitable for most classes of circle track cars and even the tow vehicle. Includes -6 AN fittings. Cooler is 14-1/2" in length and 1-3/4" in dia.

ALL52100...\$41.99



Billet Aluminum Sandwich Style Oil Thermostat

Typical Applications: Most GM and American Motors vehicles with spin-on filter.

- Center port size: 13/16-16 • Port Size: 10 AN Female O-Ring Seal
 - O-Ring O.D. : inner 2.887, outer 3.387 • O-Ring Cross Section: 0.139
- EAR503...\$110.95

Sandwich Filter Adapters

Applications: Many Honda & Acura vehicles. Some Ford. Center port size: 20mm x 1.5 • Port Size: 3/8 NPT. O-Ring O.D. : 2-3/4 & 3-3/8 • O-Ring Cross Section: 0.139

EAR514...\$40.91

Offset V-Belt



5" diameter pulley uses stock (3-bolt) mount pattern w/1.16" bolt circle.

MOR64887.....\$70.07

A	B	C	Part #	
8-1/4	6-1/2	2SET50-107-7612	..\$106.95
8-1/4	6-1/2	3SET50-110-7612	..\$122.95
8-1/4	6-1/2	5-3/4SET50-119-7612	..\$170.95
8-1/4	6-1/2	7-1/2SET50-125-7612	..\$206.95
8-1/4	6-1/2	22-1/2SET50-172-7612	..\$606.95
13	11-1/4	3SET50-610-7612	..\$146.95
13	11-1/4	4SET50-613-7612	..\$162.95
13	11-1/4	4-3/4SET50-616-7612	..\$182.95
13	11-1/4	5-3/4SET50-619-7612	..\$197.95
13	11-1/4	7-1/2SET50-625-7612	..\$236.95
13	11-1/4	10-1/4SET50-634-7612	..\$344.95
16	14-1/2	3SET50-910-7612	..\$158.95
16	14-1/2	4+1/2SET50-915-7612	..\$194.95
16	14-1/2	6SET50-920-7612	..\$235.95
16	14-1/2	7-1/2SET50-925-7612	..\$291.95

Therm-Hx Oil Cooler



All aluminum. Extruded oval tubes. Highest efficiency on the market.

14.75" x 6.25" x 2.5" (2) -12 & (2) 1/2" NPT..FLUDB-30416...\$293.95

Twin Pass

14.75" x 6.25" x 2.5" 2 pass (2) -12 FLUDB-30417-12...\$308.95

Legends Cooler

Tests have shown as much as 70 to 90° reduction.

16" x 10 1/2" x 1" 1/2" NPT FLUDB-30316-RTF....\$195.95

Performance Transmission Coolers

They are complete w/ -6 AN steel braided line and fittings.

(3/4" x 7-1/2" x 15-1/2") w/Mounting Kit (22,000 GVW)

TCI823500.....\$87.77

(3/4" x 10" x 15-1/2") w/Mounting Kit Max Protection (26,000 GVW)

TCI823800.....\$98.65

Original Design Vacuum Pumps



Pulls Much More Vacuum Than Stock "Smog" Pumps. Billet Alum Housing. Special Vane Material for Improved Seal and Wear. Special -12AN Inlet/Outlet Fittings Won't Leak.

3-Vane Vacuum Pump.....MOR22640.....\$575.51

For Drag race cars with a dry sump oiling system where increased crankcase vacuum is desired

4-Vane Racing Vacuum Pump.....MOR22641.....\$667.93

Enhanced Design Vacuum Pump

It pulls 13.9% more vacuum. Can be used efficiently on wet or dry-sump engines. Achieves greater vacuum sooner. Kit includes versatile mounting bracket and -12AN fittings.

MOR22642.....\$746.49

4-Vane Vacuum Pump

"Pro Mod" Style Large Cubic Inch and Blower Motors

Achieves much greater vacuum sooner. Flows up to 150% more air volume at low RPMs. Will achieve up to 26 inches of vacuum. Rotor is keyed to shaft, eliminating fastener failure. Utilizes sealed maintenance free bearings. Kit includes large 4 vane pump, billet adjustable bracket, -16AN beaded fittings.

4-Vane, Pro Mod Vacuum Pump.....MOR22643.....\$1039.31

Replacement Fittings

Special Clearance Fittings

-12AN for Moroso Vacuum Pumps #s. 22640, 22641 and 22642 and Remote Oil Filter Mt MOR23766. -16AN for Moroso Vacuum Pump MOR22643 Anodized aluminum. Radiused inlets to reduce restriction for greater flow. Includes O-ring. 2 per pkg.

-12AN.....MOR97641.....\$29.70

Vacuum Pump Line Kit

Includes 6' of steel re-enforced hose, two 90° hose fittings and two -12 degree straight hose fittings.

MOR22649.....\$128.89

Vacuum Pump, Dry Sump Pump

Drive Kits BBC and SBC

Steel, self-centering mandrel bolts directly to harmonic balancer for dead-accurate concentricity. BBC, uses 5" mandrel.....MOR63844.....\$201.69

SBC, uses 4.75" mandrel.....MOR63845.....\$198.72

V-Belt Pulley

5"-diameter pulley uses stock (3-bolt) mount pattern w/1.16" bolt circle.

MOR64885.....\$66.56

Gilmer Type

3-bolt mounting; accepts std gilmer belts 3/8-pitch & 3/4" width. 28 tooth, 3-5/16" o.d. Direct, bolt-on installation.

MOR64886.....\$124.53

Setrab Series STD

The STD cooler is provided with specialized M22 female ports to allow the use of high quality Setrab AN and pushlock adapters in sizes appropriate to the application.

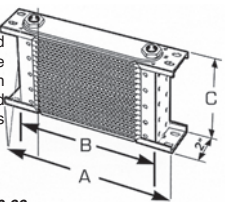

- 4.....SET22-M22AN04-SE...\$9.00
- 6.....SET22-M22AN06-SE...\$9.00
- 8.....SET22-M22AN08-SE...\$9.90
- 10.....SET22-M22AN10-SE...\$9.90
- 12.....SET22-M22AN12-SE...\$10.95
- 16.....SET22-M22AN16-SE...\$10.95



Oil Cooler

5" x 23" Oil Cooler (Mounts to Radiator)
ART100601.....\$498.95



Wing Mount Oil Cooler

ART15512.....\$341.95



Breather Tank

All-alum, LW tank features mounting straps. Size: 3-1/8" dia., 6-1/2" tank height (w/o filter), 11-1/2" overall height.

Tank -12 AN...MOR85465...\$93.57

Tank -16 AN...MOR85475...\$102.17

Breather Tank, Vacuum Dry Sump Pump 2.5 Qt

2.5 Qt tank complete with dual -12AN fittings allowing hookup from Vacuum Pump & Dry Sump Pump. All-alum, LW 3" x 17-1/2" (installed) tank includes mounting clamp.

MOR85466.....\$113.70

Breather Tank

Sizes -12 AN fittings. Includes non-hooded, clamp-on style Filtered Breather that traps oil while allowing air to escape freely. Size: 3-1/8" dia., 6-1/2" tank height (w/o filter), 11-1/2" overall height.

MOR85500.....\$141.09

Air/Oil Separator Tank

Designed to be plumbed between the valve cover (usually) & the "IN" side of the Vacuum Pump. Sizes -12AN Inlets and Outlets and a -6AN Drain. Size: 3-1/8" dia., 6" tank height.

MOR85471.....\$125.04

Billet Alum Vacuum Relief Valve

Two styles allow fastening through valve covers (MOR22637) or threaded directly into intake manifold (MOR22636).

MOR22636.....\$82.39 3/8" NPT

MOR22637.....\$82.39 3/4" - 16 Thread

Vacuum Pump Regulator

Regulator screws directly into the vacuum pump's -12AN inlet. 60° directional adj.

MOR22633.....\$151.01

Vacuum Pump Bkts

Moroso "Original" Style Vacuum Pumps. Use this bkt to mt pump to motor plates on ALL engines. Also mounts to BBC and SBC cyl heads.

MOR63910...\$64.95

Auto Trans Oil Cooler

It uses "heat sink design" to dissipate the excessive heat build up in racing trans. Made of alum w/500 sq. inches of radiation surface for high heat transfer. Size 3" dia, 12" length, and weighs only 1 lb. Comes complete w/filter cartridge, includes two 1/4" NPT to 3/8" line fittings.

MOR41200.....\$102.41

Breather Tanks



1-1/2" breather with washable element, drain, and one or two 3/8" NPT bung(s). Ideal for dry sumps and rear ends.

Tank w/1 Bung...ALL36108...\$63.99

Tank w/2 Bungs...ALL36109...\$66.99

Remote Fill Tank

It has a -10 AN outlet & recessed mounting flange to allow flush-mounting on rear deck. Remote Gear Oil Filler

ALL36110.....\$54.99



HTD Pulleys

Rock Guard w/screws for 40-Tooth HTD Pulleys **KRC42365000**
KRCKRC89008040\$29.99

40 Tooth HTD Alum Pulley (Cast Iron Pump)
KRCKRC50315500\$135.77

Inline Temp Port **Peterson**

In line temp port provides an easy way to get accurate readings from your temp gauge. Standard 5/8" 18 thread temp sender screws right in, keeping the sender in constant contact with oil.

-10 AN x -10 AN ...PET09-1940.....\$83.81
-12 AN x -12AN...PET09-1960.....\$83.81

Oil Pressure Fitting

It is extended 2-1/4", making it easier to connect the line to your oil pressure gauge.

1/8" NPT x #3JOE42799\$15.95
1/8" NPT x #4JOE42800\$15.95

Temp Tees

Want to keep an eye on engine temps? Simply install a Temp Tee Fitting where you need it. The bulk head design installs in line allowing you to quickly and securely route your AN hoses in perfect fashion. Use for water or oil temp.

#10 ANJOE42140\$52.95
#12 ANJOE42141\$52.95
#16 ANJOE42142\$52.95

Freeze Plug Adapter

Replace freeze plugs in your chevy block with our adapters and you can change the flow of water for better cooling. 1.627 +.001 -.000 Diameter. Freeze Plug to #8 Fitting.....JOE36200.....\$21.95

Filter Screens

Inline Oil Filter -10MOR23850 ..\$58.07
Inline Oil Filter -12MOR23860 ..\$58.67
Fitting Filter, 3/4"-AN12MOR23960 ..\$27.67
Fitting Filter, AN12-AN12MOR23961 ..\$26.92

Chevy 1" Drive Mandrel

To be used with BRP pulleys 1006 and 1006B
2 1/4" long.....BRP942.....\$41.66
3 1/4" long.....BRP943.....\$47.26

Mandrel Spacers

1/4"BRP960\$9.33
3/8"BRP961\$9.33
1/2"BRP962\$9.33
5/8"BRP963\$9.33
3/4"BRP964\$11.87
7/8"BRP965\$11.87
1"BRP966\$11.87
1 1/4"BRP967\$11.87
Guide WasherBRP972\$9.16

GM Front Mandrel Bolts

8740 chrome moly steel front mandrel bolts. Rated at 200,000 psi tensile strength and durability.
Head Style: 12 point.

Dia	Length	Thread Length	Socket Size	Part #	
7/16	6.000	1.100	1/2	ARP330-0701	\$30.64
1/2	6.000	1.100	9/16	ARP330-0702	\$30.64
7/16	6.250	1.150	9/16	ARP330-0703	\$30.64

1" Wide Cog Pulleys

28 tooth 5/8" ID...BRP986\$78.76
30 tooth 5/8" ID...BRP987\$78.76
15 tooth 1" ID...BRP981\$29.15
16 tooth 1" ID...BRP983\$34.39

Crank Pulley Spacer

1-1/4" thick spacer bolts behind lower pulley to allow serpentine pulleys to line up with long water pump. Ultralight weight design- weighs just 0.8 pounds. Machined from billet 6061 Aluminum.
BRP953-125.....\$31.32

Access Door **MOROSO**

.050" aluminum door is hinged to frame making easy access to fuel cells, dry sump tanks or etc. Door held securely closed with self-ejecting, flush-head fastener. 6" x 6" door, 8-1/8" x 8-1/8" overall.
MOR85700\$55.06

Positive Seal Vented Fitting -12AN

Screws into side of valve cover. Provides leak free-o-ring seal on any flat valve cover surface.
-12AN FittingMOR22635\$51.13

Oil Pump Pulleys and Belt Guides



Radius 40 Tooth Oil Pump Pulley 1.25" Wide x .625" Bore, 3/16" Key.....JONOP-6103-40-11/4.....\$81.80
Radius 38 Tooth Oil Pump Pulley 1.25" Wide x .625" Bore, 3/16" Key.....JONOP-6103-38-11/4.....\$78.65
Radius 40 Tooth Billet Aluminum Belt Guides with Bolt KitJONBG-6108-40S\$35.40
Radius 38 Tooth Billet Aluminum Belt Guides with Bolt KitJONBG-6108-38S\$33.40
30 Tooth, 1.25" Wide x .625" Bore, 3/16" key, Gilmer OP PulleyJONOP-4103-30-SQ\$61.60
28 Tooth, 1.25" Wide x .625" Bore, 3/16" key, Gilmer OP PulleyJONOP-4103-28-SQ\$58.19

BICKNELL Racing Products

Remote Oil Filter Mts

For HP1 style Oil Filter.....BRP555\$122.97
For HP4 style Oil Filter.....BRP557\$122.97
For HP6 style Oil Filter.....BRP559\$140.08

SBC Block Mount for BRP557/BRP555
Remote Oil Filter Mount...BRP550\$46.86

Peterson

Dry Sump Return Manifolds

Return line manifolds consolidate scavenge return lines from the pump to a single return line to the oil tank.

3 Stage Manifold
-12, -12, -12...PET10-0001 ..\$90.69

Y Type Manifold
-12, -12, -12...PET10-1721 ..\$93.76
-12, -12, -16...PET10-1725 ..\$116.10

Oil Filters

Oil Filters

Flow Rate GPM...28

Thread...Filter...Filter...Bypass.....Anti-Drain
Size.....Height...OD.....Valve Setting...Back Valve
13/16-16...5.17.....3.6.....None.....Yes
1 Quart.....WIX51061R...\$11.19

1-1/2-12...6.21.....4.6.....18-22 PSI.....No
2 Quart Remote...WIX51222R...\$23.95



Fram Oil Filters

1 quart FordFRAHP-1\$12.95
1 quart ChevyFRAHP-4\$10.95
2 quart Remote.....FRAHP-6\$22.95

Oil Filters

1 quart Ford.....K&NHP-3001.....\$11.47
1 quart Chevy.....K&NHP-3002.....\$12.09
2 quart Remote...K&NHP-5001.....\$25.99

MOROSO

Oil Filters

Chevy, 13/16" -16 UNF thread, short design (4-9/32" high), burst strength: 350 psi (max.)
MOR22459\$14.46
Chevy, 13/16" -16 UNF thread, long design (5-1/4" high), burst strength: 350 psi (max.)
MOR22460\$14.18
Chevy where space allows, 2 qt cap, 13/16" -16 UNF thread, extra long design (8" high), burst strength: 350 psi (max.)
MOR22461\$16.86
High-Capacity (HP-6 Replacement) 1-1/2" -12 UNF threads, 6-1/4" tall, burst strength: 675 psi (max.).
MOR22465\$32.78

Chrome Oil Filters **MOROSO**

Outside is a triple process chrome plated steel housing that's hand polished and rack nickled before chroming to insure the highest luster possible.

Chevy type, Short Design (4-9/32" high), 13/16" -16 UNF thread.MOR22300 ..\$23.06
Chevy type, Long Design (5-1/4" high), 13/16" -16 UNF thread...MOR22320 ..\$23.06

Oil Pressure Fittings

-3 St. to 1/8 NPT
EAR968803 ...\$10.00

-4 St. to 1/8 NPT...EAR968804...\$10.00

Oil Pressure Gauge Fittings

Fitting is 1/8" NPT on engine side & -4 AN for gauge connection.
90° Gauge Fitting ..PET15-1040 ...\$27.30
Straight FittingPET15-1041 ...\$14.62

Remote, Large Dia Oil Filter Mount

It includes two 3/8"-16 threaded holes on backside for mounting. Accepts -12AN threaded fittings w/O-rings; fittings can also be welded in place
MOR23766.....\$123.92

Remote Oil Filter Mounts

Tapped for 1/2" NPT inlet and out-let. Center port for pressure or temp gauge plumbing.

Flow Direction	Filter
R-in L-out Ford or Chrysler	MOR23700...\$50.77
L-in R-out Ford or Chrysler	MOR23710...\$50.77
R-in L-out Chevy V8	MOR23750...\$50.77
L-in R-out Chevy V8	MOR23760...\$50.77

SBC Oil Filter Adapter

Stock replacement adapter bolts to the engine block & accepts oil filter.

Oil Filter Adapter.....ALL92000 ..\$12.39
Two Fasteners for Oil Filter Adapter
ALL92001 ..\$5.99

Remote Oil Filter Mts

1/4" NPT Front and Side Port Styles
For Chevy style spin-on filters (13/16" - 3/4" O-ring). Made from billet alum for strength, doesn't crack and isn't porous like cast alum. Designed with (2) -12AN inlets and (3) outlets. Includes (1) -12AN and (2) 1/4" NPT.
Side Port StyleMOR23763 ...\$137.16
Front Port Style ...MOR23764 ...\$137.16

Crankshaft Socket Tools

Designed to simplify the task of crankshaft rotation during short block assembly with the balancer removed. MOR61765 features full steel construction with a zinc-plated finish for corrosion resistance. Manufactured of tool quality steel with gold iridite finish. Accepts 1/2" drive.
Crankshaft Socket Tool, Small Block & 90° V6 Chevy & Super Duty Pontiac/GM 4 Cyl
MOR61760\$32.25



WATER PUMPS

EMP Stewart Components Stage 1 Water Pump



Stock appearing cast iron design, but with improved bearings and impeller.

- High Flow at Lower RPM's for Better Cooling
- CW Rotation for V-belts
- Precision ground dual pattern fan hub for perfect pulley alignment • High Flow Impeller

Short SBC, 5/8" Shaft, 5.625" WP Length STEW12103...**\$89.95**

3/4" Shaft, 5.625" WP Length STEW12203...**\$89.95**

Adj billet hub, 3/4" Shaft, 5.625" WP Length STEW12203-BH...**\$101.95**

Long SBC, 5/8" Shaft, 6.932" WP Length STEW13113...**\$88.95**

Short SBC 71-82 Vette Only, 5.795" WP Length STEW13103...**\$88.95** **CRATE 602**

Stage 2 Water Pump



Extra material to allow drilling for extra coolant lines. Short style.

- Equal flow to left and right cylinder heads
- High flow and pressure
- 356-T6 heat treated alum specially ribbed casting
- Precision ground fan hub w/dual bolt pattern
- Zinc-plated rear cover and bolts
- Two 1/2" NPT auxiliary inlets
- Clockwise Rotation • High Flow Pump
- Cast Aluminum Finish

Alum SBC, 5/8" Shaft, 5.625" WP Length STEW22103...**\$157.95**

Alum SBC, 3/4" Shaft, 5.625" WP Length STEW22203...**\$156.95**

Alum SBC - Long, 5/8" Shaft, 6.932" WP Length STEW23113...**\$156.56**

Alum BBC, 3/4" Shaft, 5.750" WP Length STEW21204...**\$173.95**

Stage 3 Water Pump

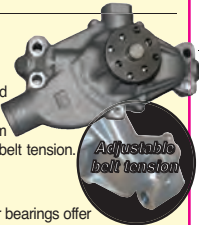

1/2" thick fan hub preferred by many top engine builders for high rpms. Alum SBC w/provision to adjust belt tension. Short style. 3/4" shaft.

- Aluminum Casting
- Models with 3/4" ball/roller bearings offer five times the strength of standard bearings
- High flow impeller
- Equal flow to left and right cylinder heads
- High flow and pressure
- 356-T6 heat treated aluminum specially ribbed casting
- Zinc-plated rear cover and bolts
- Two 1/2" NPT auxiliary inlets
- Precision ground 1/2" steel billet fan hub with dual bolt pattern for perfect pulley alignment
- Fan hub set screw for positive positioning.

SBC, 5.625" WP Length...STEW32200...**\$184.95**

BBC, 5.750" WP Length...STEW31203...**\$184.95**

Stage 4 Water Pump



This CNC machined 6061-T6 aluminum 8 vane impeller is the key to this pump, flowing up to 41% more water at twice the pressure, while consuming less than 3 horsepower at 4500 pump rpm! Short style.

SBC 3/4" shaft high flow, 5.625" WP Length STEW42203...**\$271.95**

w/adjustable mounting holes, 5.625" WP Length STEW42200...**\$281.95**

BBC 3/4" severe duty, 5.750" WP Length STEW41203...**\$281.95**

Vette 71-82 High Flow, Cast Aluminum, 5.795" WP Length STEW43103...**\$271.95**

Ford Pass Cars 70-78 and SBF SVO, Cast Alum, 5.700" WP Length...STEW46113...**\$281.95**

Radiator Water Restrictor



Run 15" cooler, place in the bottom of the radiator and remove all other restrictors. JONRR-9104-A...**\$31.41**

Billet Alum. Water Pump Spacers

1/4".....JONWP-9104-1/4-SB...**\$26.01**

3/8".....JONWP-9104-3/8-SB...**\$28.90**

1/2".....JONWP-9104-1/2-SB...**\$26.01**

1/4".....JONWP-9104-1/4-BB...**\$34.90**

3/8".....JONWP-9104-3/8-BB...**\$31.41**

1/2".....JONWP-9104-1/2-BB...**\$31.41**



MOROSO Water Pump Spacer Kits

Converts "short" 68-earlier design Chevy water pumps to longer, 69-later design. Also heat-treated bolts and gaskets.

SBC and 90° V6 Chevy. Converts MOR63500 or MOR63505 short water pump to the longer late-model designMOR63510...**\$44.00**

BBC. Converts MOR63520 short water pump to the longer late-model design...MOR63610...**\$47.12**



Overflow Tank

NHRA and IHRA accepted. Holds a full quart. Barbed fitting on top, petcock on bottom. 10-1/2" high overall - 3" diameter. MOR63657...**\$35.64**



40 Below Coolant

Reduces water temp up to 40 degrees. 2 cans provide better results. PROB4032**\$19.95**

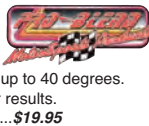

Purple Ice

"Reduces temps and protects against corrosion" It is a high perf, synthetic, radiator coolant additive for both gasoline & diesel engines. ROY01600...**\$9.71**



CSP

Impurities in well water can cause rust and corrosion inside the rad, water pump and cylinder heads, and this can lead to a loss of cooling efficiency. It stops the adverse effect of hard water better than the leading brand of coolant additives. 1 QuartJGR50030...**\$8.99**

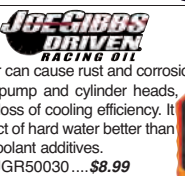

Poly Overflow Tanks

- 6AN inlet and vent
- Swivel petcock

1 Gallon Overflow...JAZ600-100-01...**\$63.01**

Mounting Strap Kit...JAZ400-001-03...**\$38.21**

- 1/4" Elbow Inlet

1 Quart Overflow...JAZ600-025-01...**\$23.40**

(In Natural Color)...JAZ600-025-05...**\$23.40**



MOROSO Universal WP Pulley Shim Kit

Kit provides proper drive belt alignment with water pump. Shims are installed between the water pump pulley and drive flange. Kit contains (2) 1/16" spacers and (1) 1/8" spacer. Fits all GM and Ford water pumps with either a 3/4" or 5/8" shaft. MOR64035...**\$7.08**



Edelbrock

Alum. Water Pumps Small Block Chevy



EDE8810*1955-68 short style.....**\$251.55**

EDE8820.....Polished version of EDE-8810**\$357.05**

EDE88111969-87 long style except Corvette, 1973-86 truck**\$238.75**

EDE8821.....Polished version of EDE-8811**\$320.75**

EDE8812.....1971-82 Corvette, short style.....**\$256.85**

EDE8815.....1984-91 Corvette, short style.....**\$258.95**

EDE8881.....1987-94 with serpentine belt except LT1 and Corvette, 5/8" shaft**\$274.95**

Big Block Chevy

EDE8850**1965-68 short style.....**\$290.95**

EDE8851.....1969-87 long style except Corvette and 1 ton truck**\$295.25**

EDE8852.....1971-74 short style Corvette.....**\$292.05**

EDE8854.....Short style pump for aftermarket serpentine belts.....**\$240.85**

Small Block Ford

EDE8840.....1986-93 5.0L.....**\$236.55**

EDE8841.....1965-68 289, 1968-69 302, 1969 351W.....**\$227.05**

EDE8842.....1965-67 289 H.O.....**\$221.65**

EDE8843.....1970-78 302, 1970-87 351W**\$239.75**

EDE8844.....1971-79 351C/351M/400**\$245.15**

EDE8866.....1970-92 429-460.....**\$283.45**

EDE8805.....1965-76 352-428 FE**\$295.25**

Chrysler 361-440

EDE8814.....1958-79 models**\$185.45**

*Also fits 1969-70 Corvette, 1955-72 truck
**Also fits 1969-70 Corvette, 1966-72 truck

Victor Circle Track Water Pump



Featuring a revised impeller entry and a .100" thicker rear cover for greater durability, they provide maximum cooling with equal distribution to the both sides of the block. SBC, -8AN aux. fittings 90° to the block.....EDE8816...**\$277.05**

SBC, 3/8" NPT aux. fittings 45° to the block EDE8817 **\$268.55**

SBF, Windsor style blocks, left hand inlet.....EDE8833...**\$261.15**

Victor Pro Series 2-Pc Water Pump for SBC



This SBC is designed for high output racing engines, especially dirt late model & circle track apps. The 2-piece design features improved symmetrical flow paths resulting in increased flow & requiring less horsepower from the engine. EDE8827**\$337.85**

MOROSO

Thermostatic Water Pump Switch

It has 3 settings: Auto, Manual and Off. In the "Manual" position, the motor is constantly on. Contact rating of switch is 15 amps at 32 volts; use with 10 amp fuse (not included). MOR63760...**\$60.31**



Aluminum SB Water Pump

Features a low drag impeller that frees up an extra 14 hp at 7,500 rpm. Built in cam stop. Pre '69 short style with 5/8" shaft. MOR63500.....**\$154.26**



Alum. SBC '71-82 Corvette Design 3/4" Shaft

Large diameter shaft & extra housing reinforcements for Oval Track. Includes integral cam stop boss. Two 1/2" NPT auxiliary ports for external lines. Multiple pattern Drive Hub. Spacer Kit MOR63510 converts the MOR63500 pump to the '69-later "long" design. MOR63505**\$215.89**



Billet Electric Water Pumps SBC, Stock Mount

They pump up to 21% more water through the system during actual operating conditions than any competing pump. MOR63557.....**\$385.09**





Color Options Chart

B = Blue • C = Chrome • R = Red • S = Black • U = Polished
Add appropriate letter to end of part #.

Chevy 100 & 200 Series WP



Recommended for Sport, Drag Cars, and Mild Street Cars. All 100 and 200 Series pumps for Chevys are machined with enough back spacing to clear cam belt drives and are compatible with most roots blower drives. Passenger side inlet port std.
• 35 GPM Standard • 40 GPM Heavy Duty
• Options for Heavy Duty or 16 Volt
BBC 396-502MEZWP100U\$355.52
SBC 4.3 V6, 262-400MEZWP101U\$345.34

Chevy 300 Series WP

It changed the rules about using electric pumps on high horsepower street engines, nitrous motors, or super/turbo charged cars. Delivering 55 gallons per minute of flow, the 300 series pumps offer great cooling solutions to high horsepower vehicles. Higher flow rates reduce the chance of detonation.
• Options for 16 Volt
BBC 396-502MEZWP300U\$464.53
SBC 4.3 V6, 262-400MEZWP301U\$464.53



Water Pump LT-1 (Black Only)

It has proven our reliability with customers logging 50,000 to 60,000 miles on their daily drivers. The need for the heavy and expensive factory timing chain is also eliminated. Some F-bodies may require trimming of the fan shroud. No inlet required. Frees over 10 rear wheel HP.
• Options for Heavy Duty or 16 Volt
'93-'97 Camaro/Firebird • '93-'96 Corvette • '93-'96 Impala/Roadmaster
MEZWP118\$256.78



Water Pump LS-X

It will dress out your engine while increasing mid range power and low speed cooling. Originally designed for Stock and Super Stock racers, this pump can also be found on street rods, dune buggies and modified street cars.



35 GPM Standard or 40 GPM Heavy Duty
• Compact & LW • Driver or Passenger side inlet ports
• Options for Heavy Duty or 16 Volt
'98-02 Camaro/Firebird • '97-04 Vette • Chevy/GMC 5.3
MEZWP119U\$490.34
55 GPM High Volume, Great for street driven cars includes heater ports.
MEZWP319U\$777.87

SBF 100 Series Water Pump



It is the most common pump body for SBF engines. It will bolt up to front covers from the very early 64 style thru 93 and slightly beyond. It has been used as the heart of many cooling systems and can be coupled with one of several different back plates to complete your system right.
MEZWP111U\$367.75

We offer a variety of plates to mate with the WP111 pump. One of these back plates is used to cover the center chamber in a stock type front cover. The back plate will not be used if you are using a modern belt cam drive system. Choosing correctly will ensure easy installation.
Options for Heavy Duty or 16 Volt • Thickness .19"
221-289 earlyMEZWP112U\$51.61
Traditional 289/5.0MEZWP113B\$51.61
ClevelandMEZWP123R\$51.61

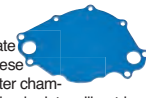

SBF Water Pump

WP173 is the right choice if you have a later model front cover on your 5.0 or 351 engine. This is known as the '94-95 design and is also shared by Ford Motorsport front covers. In addition, this has been the design chosen universally for front covers purchased with belt cam drive systems. This pump is shipped with O-rings for a positive pump-to-plate seal.



35 GPM Std • 40 GPM Heavy Duty
• Options for Heavy Duty or 16 Volt
'94-'95 Short SB FordMEZWP173U\$393.56
It comes with a std gasket because these are compatibility issues with several belt drives and o-rings.
Back PlateMEZWP174U\$51.61



Remote Water Pumps Mini Inline and Bulkhead

Our original remote makes a very clean installation when mounted to the back side of a V-8 motor plate. All the plumbing faces forward, with a single 1" NPT inlet and two -12 O-ring boss outlets. No water manifold is required. It also sits nicely into a fender well or out-of-the-way spot to provide more clearance in front of your engine. One 1" NPT inlet and two -12 outlets required.
35 GPM Std or 40 GPM Heavy Duty



Std Options for Heavy Duty or 16 Volt
MEZWP116U\$316.14
High Flow Options for 16 Volt
MEZWP316U\$393.56

Water Pumps Imports, Honda, and Toyota

These kits replace the OEM timing belt driven water pump with an idler pulley and block-off plate. The pumping is performed by a remote pump spliced into the lower radiator hose. A bracket is supplied to mount the pump to the transaxle. Installation of the idler plate is identical to shop manual instructions for water pump replacement. The job requires advanced knowledge to compete. **20 GPM Std.** Kit includes: Pump-WP136 • Pump mounting bracket. Idler plate w/O-ring. Hose adapter fittings. Toggle switch and crimp connectors. Our idler assemblies are used as a block-off for the factory mechanical water pump and to maintain timing belt tension.



1.6/1.7/1.8 Type R (8.6 lbs) MEZWPK50022...\$445.18
1.8/2.0/2.1 (8.6 lbs)MEZWPK50019...\$445.18
2.2/2.3 (8.6 lbs)MEZWPK50026...\$445.18

Remote Water Pumps Mini Inline and Bulkhead

Designed for sport compacts, small engine applications and water to air intercoolers. The new dual outlet is well suited for alcohol powered drag cars. Many customers use it to replace existing inline pumps for increased reliability and performance. The pump may be small, but the quality and reliability is just what you have to come to expect from Meziere.



6.3 lbs. (7.25" Height)MEZWP136S\$225.82

Remote Water Pumps Hi-Flow Inline & Mech

Our most versatile pump design to date, combining an inline configuration with a 55 GPM flow rate and interchangeable fittings. Inlet and outlet ports are O-ring boss. AN thread. Smooth hose or AN line in and out. 1.300 ID inlet available. Can be spliced into lower radiator hose. Dual -16 outlet ports.



Single outlet (Inlet WN Style) (Outlet WN Style)
MEZWP336S\$451.62

Dual outlet (Inlet WN Style) (Outlet 2X-16AN)
MEZWP337S\$451.62

Chevy Spacers

Big Block Chevy
ThicknessO'Ring
1.5"2 sidesMEZWPS100-1.5U\$51.61
1.75"2 sidesMEZWPS100-1.75U\$57.81



Small Block Chevy
ThicknessO'Ring
0.9"noneMEZWPS101U\$40.64
1.5"noneMEZWPS101-1.5U\$51.61

ALLSTAR Aluminum SBC WP

Short, LW pumps dissipate heat more rapidly and equalize water flow to both sides of the engine. Billet steel fan hub and bosses for external water lines are included. Above this RPM, use the ALL31105 pump with a 3/4" bearing. It may need to be cleared for use with 8" dampers. 71-82 Corvette.
ALL31105\$96.99



Polished Water Necks

They are two-piece necks that can swivel 360 degrees. Each has a polished finish and includes an O-ring for sealing the base flange and two chrome plated Allen head bolts.
ALL3017090 Deg. Neck\$18.99
ALL3017145 Deg. Neck\$18.99
ALL30172Straight Neck\$15.49



Chrome Plated Water Neck 45°

It fits SBF. Includes an O-ring for sealing the base flange and two hex head bolts.
ALL30174\$13.99



1:1 Pulley Kits For SBC

LW double groove alum pulley kits include crank & WP pulleys & belts for Allstar block or head mt power steering pump. Use short water pumps w/5/8" dia hole.



ALL31080\$89.99Kit For Block Mt P/S Pump
ALL31082\$89.99Kit For Head Mt P/S Pump

Related Components

ALL31084\$33.991:1 Crank Pulley (6-5/8")
ALL31085\$45.991:1 Water Pump Pulley (6-5/8")
ALL86121\$9.99Belt, Crank to Water Pump, 34"
ALL86123\$9.99Belt, Crank/Water Pump/Block Mount P/S Pump, 41"
ALL86125\$10.99Belt, Crank/Water Pump/Head Mount P/S Pump, 44"

Fan Freewheeler

It allows the use of a mech fan when needed, along with the option to let the fan "freewheel" for optimum horsepower at times like qualifying. Simply engage or disengage one thru-bolt to use the fan or let it "freewheel". Freewheeler spaces the fan 2.375" from the pump and is designed to fit 3/4" water pump shaft only.
ALL30078\$104.99



WN Style Fittings

-20 AN fittings used for thermostat housings and some 300 Series pumps.



Smooth Hose

1-1/4"MEZWN0031U\$19.35
1-1/2"MEZWN0032U\$19.35
1-3/4"MEZWN0033U\$19.35

Extended Hose

1-3/4"MEZWN2033U\$25.81
2" ExtMEZWN2000U\$25.81



AN Hose

-10MEZWN0042U\$19.35
-12MEZWN0043U\$19.35
-16MEZWN0040U\$19.35
-20MEZWN0041U\$19.35
-24MEZWN0044U\$19.35



Standard 1" NPT Pump Fittings

For use with most of our 100 and 200 Series pumps.

Smooth Hose

1-1/4"MEZWP1125U\$19.35
1-1/2"MEZWP1150U\$19.35
1-3/4"MEZWP1175U\$19.35



Extended Hose

1-1/4"MEZWP2125U\$19.35
1-3/4"MEZWP2175U\$19.35
2" ExtMEZWP1000U\$19.35



AN Hose

-12MEZWP1012U\$19.35
-16MEZWP1016U\$19.35
-20MEZWP1020U\$19.35

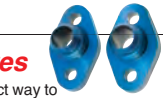

Male AN Block Plates

Male AN block plates are the perfect way to make the connection to the front of the engine when using a remote or rad mounted pump. They are sold in pairs and are delivered to you with the required O-rings & hardware.

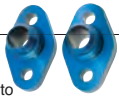

BBC (12AN Male Ext Thread) .MEZWP8012ANU \$58.07
BBC (16 AN Male Ext Thread) MEZWP8016ANU \$58.07
SBC (12 AN Male Ext Thread) MEZWP8112ANU \$58.07
SBC (16 AN Male Ext Thread) MEZWP8116ANU \$58.07

RADIATORS

BSC400-49900-MT **BSC400-49910-MT**

Warning:
To prevent radiator failure do to electrolysis; Be sure engine is properly grounded.

Northeast DIRT Modified Radiators
Alum, Race ready Big Block capacity Radiators w/1/4 NPT fitting and fan shroud bkts, NO cap. Aluminum Brazed Core. 2 Rows 1.5" Tubes, 11 fins per inch. Direct Drop – in replacement for all Bicknell, PMC, TEO, Troyer & similar Modified Chassis'. Complete with Fan shroud mounting tabs. Lightweight 22 lbs. Extremely efficient & easy to clean. Proven successful by top Modified teams.

Double Pass Right, Top Right, Bottom Right Radiator
23.5" x 23.5" x 3.5"BSC400-49900\$339.95
23.5" x 23.5" x 3.5" with Mounts.....BSC400-49900-MT.....\$385.00

Cross Flow Unit, Top Left, Bottom Right Radiator
23" x 23" x 3.5"BSC400-49910\$339.95
23" x 23" x 3.5" with Mounts.....BSC400-49910-MT.....\$385.00

BSC400-49900 **BSC400-49910**

Aluminum Radiators

Two-row 1" core. 1-1/2" top radiator inlet, 1-3/4" bottom rad outlet. Exclusive crossflow tube design dramatically increases cooling. Reinforced die-stamped tanks for added rigidity. Machined-billet filler neck for better pressure control. Brazed core for extra durability. TIG-welded tanks. 100% Virgin Alum-NO Recycled Material. Chevy/GM-style rads are a top left (driver) & bottom right (passenger) configuration, & Ford/Chrysler-style rads are a top right (passenger) & bottom left (driver) configuration.

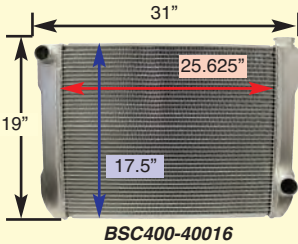

Chevy/GM-Style Aluminum Radiator Top Left/Bottom Right

Overall Size	Core Size	Part #	Price
22" x 19"	16.875" x 17.5"	BSC400-40010	\$159.98
24" x 19"	18.875" x 17.5"	BSC400-40011	\$159.98
26" x 19"	20.875" x 17.5"	BSC400-40012	\$163.14
28" x 16.5"	22.875" x 15"	BSC400-40018	\$189.95
28" x 19"	22.875" x 17.5"	BSC400-40014	\$163.14
31" x 19"	25.625" x 17.5"	BSC400-40016	\$159.98

Inlet Fittings

O'ring is included with each fitting. **A.** 1-1/2" Screw-In Adapter for Standard Hose
BSC400-40238AN\$16.27
B. 16AN Screw-In Adapter Fitting
BSC400-40239AN\$15.95
C. 20AN Screw-In Adapter Fitting
BSC400-40240AN\$15.95

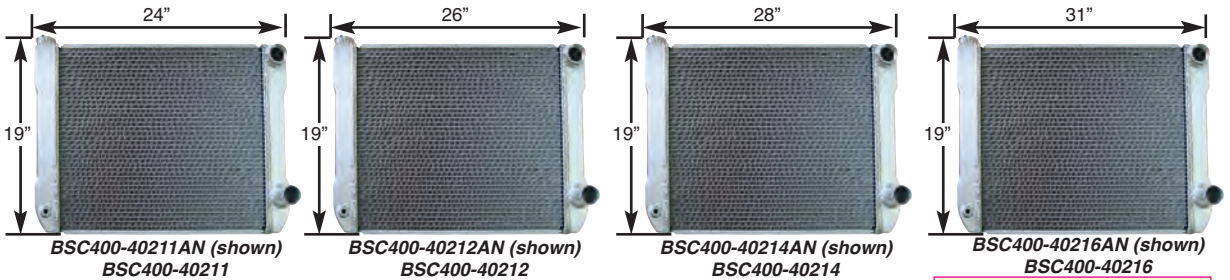

GM Radiator Double Pass TR/BR

Featuring univ inlets to accept 1-1/2" std hose, -16 or -20AN fittings (sold separately). The water is circulated across the top half of the rad, then back across the bottom half, allowing twice the heat dissipation. These rads offer the same features as the std alum rads including furnace brazed tanks, 2 rows of 1" tubes, billet machined filler neck with overflow & a std 1-3/4" outlet.

24" x 19" (AN Fitting Style)	BSC400-40211AN	\$195.95
26" x 19" (AN Fitting Style)	BSC400-40212AN	\$195.95
28" x 19" (AN Fitting Style)	BSC400-40214AN	\$199.95
31" x 19" (AN Fitting Style)	BSC400-40216AN	\$195.95
28" x 19" Top Left Inlet / Angled Bottom Right Outlet	BSC400-59910	\$186.72
28" x 19" Top Right Inlet / Angled Bottom Right Outlet	BSC400-59900	\$204.18
28" x 19" Dimpled Top Right Inlet / Angled Bottom Right Outlet	BSC400-59900-AN-D	\$295.34

Top RH Welded 1-1/2" Tube
24" x 19".....BSC400-40211\$185.00
26" x 19".....BSC400-40212\$187.77
28" x 19".....BSC400-40214\$185.00
31" x 19".....BSC400-40216\$184.09

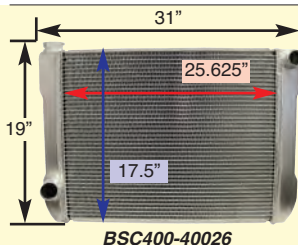

Ford/Chrysler-Style Aluminum Radiator Top Right/Bottom Left

Overall Size	Core Size	Part #	Price
22" x 19"	16.875" x 17.5"	BSC400-40020	\$159.95
24" x 19"	18.875" x 17.5"	BSC400-40021	\$159.95
26" x 19"	20.875" x 17.5"	BSC400-40022	\$159.95
28" x 19"	22.875" x 17.5"	BSC400-40024	\$163.14
31" x 19"	25.625" x 17.5"	BSC400-40026	\$159.95

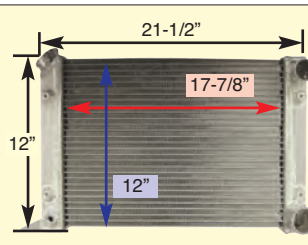

Sciocco/Pro Stock Style LW Aluminum Radiator

2 row 1" core design with a compact overall size of 22" w x 13" h. Machined billet filler neck, 1-1/2" top inlet & bottom 1-3/4" outlet.
• 21-1/2" w x 12" h Overall (25-3/8" Tab to Tab)
• 17-7/8" w x 12" h Core
BSC400-46600.....\$224.95

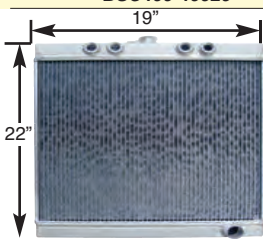

Sprint Car Radiator

With furnace brazed tanks provide superior cooling in sprint applications. They feature machined filler neck, 1-1/2" RH bottom outlet and four female top outlet ports for use with -10AN O-ring fittings.

22" x 19" (2L 2R BR)
BSC400-49930.....\$201.95

NEW Sprint Cross Flow 4R Stacked Bottom R 17.5" H x 20.5" W x 2.25" Thickness (Core:16.5" W x 17.25" H • Thickness:1.25")

Aluminum with Natural Finish.
Inlet/Outlet:Upper Right/Lower Right. Row Quantity:1.
Filler Neck Height:1.13".
(4) inlet fittings that are all 1/2" NPT. Cap not included.
BSC400-49933.....\$211.98

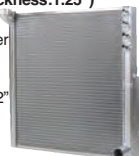

NEW Sprint Triple Pass

19.75" H x 20.25" W x 3" Thickness
These aluminum with natural finish tri pass radiators are specifically designed for 305 engines in sprint cars & are made to run 50'-70' cooler than std double pass radiators. Requires #10 o-ring boss fittings & small dia 1" radiator cap shown below. Uses the small 1" cap. Inlet/Outlet:Upper Left/Lower Right. Row Quantity:2
BSC400-49935.....\$220.46



ARTS

Dirt Modified Radiator

Twinflow Right Hand w/Front Mounts Alum
ART100115\$803.95

DIRT

Fan Shroud

19" x 27" -31" for Radiator Adjustable Fan Shroud Easy to trim for custom fit. DIR2200FS.....\$129.99



ARTS

Stacker Radiator

23.5" x 23.5" x 3.5"
ART100122R.....\$687.69

Oil Cooler for Stacker Radiator

23.5" x 23.5" x 3.5"
ART100122C.....\$478.00

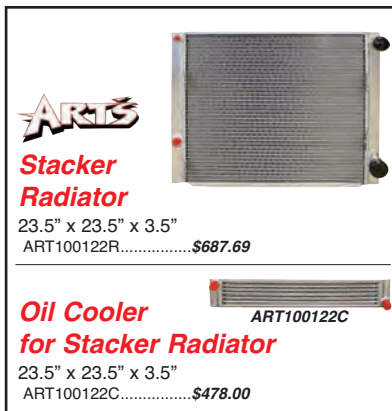

ARTS

Aluminum Twinflow Radiators with Heater

23.5" x 23.5" x 3.5"
With Mounts.....ART100121H.....\$695.50

Radiator Mounts with Rubber Vibration Mounts (pair)
ART100109R15.....\$126.95



ARTS

Fan Shrouds 15"

15" SB - StandardART4-15.....\$196.26
15" SB - **Low Profile**ARTL4-17.....\$196.26
15" SB Fan ShroudARTSBT.....\$196.26

15" BB - StandardART2-15.....\$188.99
15" BB - **Low Profile**ARTL2-15.....\$196.26

Fan Shrouds 17"

17" SB - StandardART4-17.....\$196.26
17" BB - StandardART2-17.....\$181.73
17" BB - **Stacker**ARTST17.....\$188.99

Fan Shrouds 19"

19" SB - Std 3" DepthART3-19.....\$175.00



Stand Rock Screens **ARTS**

23x23 and Stacker Dirt Modified Radiator w/1.5 front mounts No Oil Cooler cut out
ART600100\$222.95

23x23 and Stacker dirt mod rad has oil cooler notches
ART600101\$222.95

23x23 and Stacker rads for 2" and up mounts
ART600102\$222.95

20x23 Small Block rad w 1.5 mounts
ART600103\$222.95

20x23 SB Rad w/oil cooler cutout fits 1.5 mounts
ART600104\$222.95

Core Saver Two Piece Design Northeast Dirt Modified
ART600108\$266.00

Replacement Outerwear
ART2847\$47.60



ARTS

Dirt Modified Rubber Mounts

1.5"ART100109R15\$126.95
2.5"ART100109R25\$129.95
3.0"ART100109R30\$126.95
3.5"ART100109R35\$126.95
4.0"ART100109R40\$126.00
4.5"ART100109R45\$126.95

24" Radiator Air Comb

ARTBG24.....\$39.95



Expansion Tank Small Tank

Fits Crate motors & SBC/BBC motor. Right Hand Outlet Water Outlet Raised for Alt Clearance.

Right HandART100401...\$280.95
Left Hand.....ART100403...\$279.95

Expansion Tank Big Tank

Fits Crate motors & SBC/BBC motor.

Right Hand..ART100402..\$279.95
Left Hand....ART100404..\$279.95

Right Hand w/ Thermostat Expansion Tank

ART100409...\$352.95



Low Profile NE Dirt Modified, Late Model, & IMCA.

Total Height 4.5 Inches. Fits under low hood design. Each tank comes with an o-ring & mounting hardware.

Fits Dirt Modified BB, SB, & Crate has 2: 3/8" NPT Fitting for rear cooling line

ART58037E...\$385.00

Fits PA & DIRT Spec motors has 3/8" NPT fitting for rear cooling lines

ART58037L...\$351.00

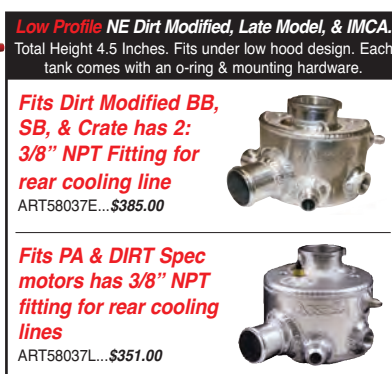

ARTS

Expansion Tank for GM Crate 525 Engine

ART525R.....\$349.96

3/4 NPT Heater 120v 600 Watt

ART11409.....\$92.75



Power Steering Reservoir Clamps on Steering Box

ART100504...\$152.95

Power Steering Reservoir Panelfast Mount Fits Teo/BRP/Troyer

ART100506...\$125.50



Left Side Oil Line Kit

BRP/Troyer -16 AN male thread
ART2010\$227.95

Left Side Line Kit With Filter Mount Accepts Peterson (PET09-0439)

ART2010F\$235.00

Peterson 75 Micron Oil Filter without Bypass -16AN Fittings

PET09-0439\$136.28



Dirt Modified Radiator Recovery Tank

ART1006041\$169.95

SBF Windsor RH outlet

ARTEXP5F...\$247.95

Upper Hose DIRT Modified

ART100408\$32.95



TRICK RACE PARTS

FSII with 17 in cut out

TRIFS6\$120.40

SBC Deeper Offset 6-1/2 deep

TRIFS7\$120.40

Late Model Fan Shroud

TRILMFS1\$83.75



NEW

BSC Components

Fan Shrouds Aluminum

Dirt Modified Twin Flow

2" Deep for 15" FanBSC400-49901\$144.50
2" Deep for 17" FanBSC400-49902\$144.13
4" Deep for 15" FanBSC400-49903\$156.80
4" Deep for 17" FanBSC400-49904\$156.80

Dirt Modified Cross Flow

2" Deep for 17" Fan
BSC400-49910-SHROUD-CROSS\$129.89



ALLSTAR

Aluminum Radiators

The Lightweight 1" tubes, arranged in 2 rows. Std 1-1/2" inlets and 1-3/4" outlets have beaded hose fittings.

19" X 22" ChevyALL30010\$169.99
19" X 24" ChevyALL30011\$169.99
19" X 26" ChevyALL30012\$169.99
19" X 28" ChevyALL30014\$169.99
19" X 31" ChevyALL30016\$169.99
19" X 22" Ford.....ALL30020\$169.99
19" X 24" Ford.....ALL30021\$169.99
19" X 26" Ford.....ALL30022\$169.99
19" X 28" Ford.....ALL30024\$169.99
19" X 31" Ford.....ALL30026\$169.99
16" X 28" Chevy.....ALL30042\$193.99
16" X 28" Ford.....ALL30043\$193.99

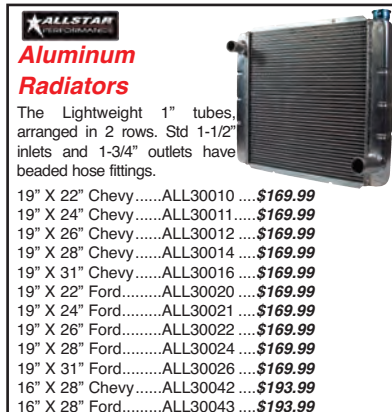

Constant Torque Clamps

#24, 1-1/16 - 2in.
BSC400-232208CT...\$7.95
#28, 1-5/16 - 2-1/4in.
BSC400-232210CT...\$7.95 **Sold Each**
#32, 1-9/16 - 2-1/2in.
BSC400-232212CT...\$7.95 **Sold Each**

Shielded Hose Clamps

#24, 1-1/16 - 2in.
BSC400-237104...\$1.30
#28, 1-5/16 - 2-1/4in.
BSC400-237204...\$1.32 **Sold Each**
#32, 1-9/16 - 2-1/2in.
BSC400-237304...\$1.32 **Sold Each**

Hose Clamps

These SS clamps are easily tightened with a deep slot hex-head screw.

1/2" O.D.ALL18330...\$2.49
1" O.D.ALL18332...\$3.69
2" O.D.ALL18334...\$3.69
2-1/4" O.D.ALL18336...\$3.99
2-1/2" O.D.ALL18338...\$3.99
3-1/2" O.D.ALL18340...\$4.99
4-1/2" O.D.ALL18342...\$4.99

Fan Shrouds

Allows fan to pull more air through the rad for increased cooling. Alum and impact resistant plastic shrouds fit fans up to 17" dia. Rad size reference is based on outside tank size.

26" GriffinALL30106...\$74.99
26" AllstarALL30107...\$74.99
28" GriffinALL30108...\$74.99
26" AllstarALL30109...\$74.99
28" AllstarALL30110...\$74.99
31" Griffin & Howe...ALL30111...\$74.99
26" HoweALL30114...\$74.99
31" AllstarALL30115...\$74.99
28" HoweALL30116...\$74.99

Radiator Shaker Screen

Includes black power coated alum frame, screen, cross rod, springs, and retaining clips. Frame size: 17" tall and 25" wide. Cross rod is 1/2" dia and 32" long.
ALL30160...\$89.99

Stainless Wire Screen

Use screen to protect rads, oil coolers or other items. Size referenced is the approx. opening of the screen.

5/64" Opening, 12" x 36".ALL22260 \$13.99
5/64" Opening, 36" x 36".ALL22262 \$37.99
1/8" Opening, 12" x 36"...ALL22265 \$15.99
1/8" Opening, 36" x 36"...ALL22267 \$39.99
1/8" Opening, 36" x 48"...ALL22268 \$46.99
3/16" Opening, 12" x 36"...ALL22270 \$17.99
3/16" Opening, 36" x 36"...ALL22272 \$49.99
3/16" Opening, 36" x 48"...ALL22273 \$56.99

Radiator Honeycomb

It mounts to front of radiator to protect from rocks and debris. Secure directly to radiator using ALL30085 mounting kit, sold separately. 19" x 26" x 1/2" thick.
ALL30158...\$23.99

Speed Screens

Speed Screen Flat Rectangle. Sheet & PVC Frame Radiator Guard.

Sprint Speed Screen Rail System
OUT11-2325-12...\$49.45
UMP Style Mod Speed Screen Kit
OUT11-2332-12...\$62.95
14 x 22 w/rail system rad screen
OUT11-2596-12...\$48.95
22 x 22 w/rail system rad screen
OUT11-2597-12...\$54.95

Radiator Hoses

2-ply coolant hose is flexible & adapts to a variety of apps. Abrasion resistant cover will not crack or harden.

1-1/2" Dia, 17" Upper HoseALL30206...\$12.99
1-1/2" Dia, 20" Upper HoseALL30208...\$12.99
1-3/4" Dia, 16-1/2" Lower Hose ALL30224...\$21.99
1-3/4" Dia, 19" Lower HoseALL30226...\$21.99

Radiator Caps

19-21 psi Small CapSTAN 10361...\$17.95
22-24 psi Small CapSTAN 10362...\$17.95
21-25 psi w/EarsSTAN 10372...\$17.95
28 to 32 psi w/EarsSTAN 10373...\$17.95
21 to 25 psi w/Lever.....STAN 10382...\$18.95
21 to 25 psi Octagonal...STAN 10392...\$17.95
29 to 31 psi Octagonal .STAN 10393...\$17.95

Radiator Cap

These high-pressure caps fit std-size radiator filler necks & increase the boiling point to improve heat transfer. 6-sided Cap for easy tightening.
19-21 lbs.....MOR63320\$12.78
27-29 lbs.....MOR63328\$12.78

5" Long Radiator Mount

Radiator Mt for SB Cars with Radiator Back. Bolts go in from the top for easy install and adjustment. Mounting nuts are captured from the side to make install easy. Black Anodized. Sold in Pairs.
BRP9342.....\$33.42

Molded Hoses

4 Ply construction strongest on the market. Wire reinforced. Part # for easy identification. Black and Red in color.

Upper Molded Hose
SBC Black.....BRP9345\$77.43
SBC Red.....BRP9345RD...\$77.43
BBC Black.....BRP9347\$77.43
BBC Red.....BRP9347RD...\$77.43

Lower Molded Hose

SBC Black.....BRP9344\$93.53
SBC Red.....BRP9344RD...\$93.53
BBC Black.....BRP9346\$93.31
BBC Red.....BRP9346RD...\$96.50

Anti Vibration Radiator Mounts

Rubber bushings on the through bolt help eliminate cracking of the side mounts on alum radiators. Mounts on the front 1-1/4" cross bar & uses a 5/16" bolt to attach to the rad. Anodized for long lasting good looks and includes zinc plated allen bolts to avoid corrosion. sold each,2 required, 5/16 cross bolt not included.
BRP9476.....\$27.81

NEW
Teo Side Oil Cooler Mount
TEOT059...\$107.25

MOROSO

Manifold Filler Neck Kit

3-1/4" high. 1/2" NPT for water sending unit. Two 1/4" NPT for returns from heads. Can flip 180° for left or right outlet.
MOR63420...\$69.04

Filler Neck Billet, Chevy, Adaptable Outlet

Manifold-mounted filler neck base is an adaptable billet version of the 1 included in Moroso Kit # MOR63420 without the filler neck or mounting hardware.
MOR63421...\$63.43

Filler Neck Housing

356-T6 cast alum base stands 2-5/16" tall, which locates filler neck at highest point to bleed off air on cars w/low-mount radiators.
MOR63423...\$38.00

Exterior Water Filler Neck

It raises water fill point 5-3/4" above manifold; ideal for bleeding off cooling system air. 45° incline of filler tube clears air scoops to provide quick and accessible filling for between rounds cool down. Includes gasket and 1/8" NPT to 3/8" i.d. barbed fitting to plumb exp tanks.
MOR63467...\$70.21

Expansion Tanks

1/4" NPT at neck, 1/4" NPT water intake on side, 1/2" NPT on bottom for return to radiator. 6-1/2" diameter.

1-1/2 quart capacity 3-5/8" deep stamped neckMOR63650\$95.28
billet neck.....MOR63651\$119.49

1 quart capacity 2-5/8" deep stamped neckMOR63655\$95.43
billet neck.....MOR63656\$119.67

Thermostat Housing Blank

For custom applications.
MOR63471...\$11.13

Filler Necks

Bolt-on Stamped.....MOR63465\$29.88
Bolt-on BilletMOR63466\$50.80
Weld-on Stamped.....MOR63485\$21.16
Weld-on BilletMOR63486\$34.93

Bolt-on Filler Neck

Bolt-on wholes for return lines and female ports
-16ANMOR63461\$73.94
-20ANMOR63463\$69.95

Water Outlet Restrictor Kit

Kit consists of 3 restrictor plates with 5/8", 3/4" and 1" i.d. holes for optimum coolant flow, 2-1/8" o.d.
MOR63440...\$7.68

Recovery Tank

Fabricated of alum for strength w/integral mounting brackets and clear coolant level check. Side bung 1/4" NPT. With straight barbed fitting, bottom bung, 1/4" NPT with petcock, 1/4" NPT plug and 1/4" NPT 90° fitting.
MOR63769...\$126.74

Radiator Hose Fillers

356-T6 cast Alum Rad Hose Fillers are spliced into upper rad hose to provide more complete cooling system filling. (cap not included) 100% leak tested.

1-1/2" to 1-1/2" hose.....MOR63730\$32.28
1-1/2" to 1-1/4" hose.....MOR63740\$32.28
1-1/4" to 1-1/4" hose.....MOR63745\$32.28



1" Thermostat Housing Spacer

It is machined to accept a thermostat and two 3/8" female pipe holes. Hoses run from the spacer to 2 points on the back of the intake manifold.
KRCKRC15375000...\$41.68

Mach Two 11" Dual



Dual 225 high perf drip through motors. All glass-filled nylon construction. Fits most GM cross-flow radiators with a minimum size of 23.5" x 15.75".

- Motor: 225 watt heavy duty
- Airflow at 0" static: 2,760 CFM
- Size (without flanges) 23.5" w x 15.75" h
- Depth: 3.80" • Amp draw: 22.0

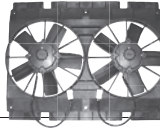

Mach One 16"

225 watt sealed motor tested in accordance with DIN EN 60529, dust and water proof to IP68. Quiet S-blade design. All glass-filled nylon construction.

- Motor: 225 watt heavy duty
- Airflow at 0" static: 2,160 CFM
- Size: 16" w x 17" h
- Depth with rubber seal: 3.90"
- Depth without rubber seal: 3.31"
- Amp draw: 17.7



Champion Series 7"

130 watt sealed motor tested in accordance with DIN EN 60529, dust and water proof to IP68. Works as a puller fan only. All glass-filled nylon construction. Includes (4) 90° mounting feet.

- Motor: 130 watt heavy duty
- Airflow at 0" static: 375 CFM
- Depth: 2.48" • Amp draw: 6.5



Champion Series 8"

Lowest profile high perf 8" reversible on the market. 130 watt sealed motor tested in accordance with DIN EN 60529, dust and water proof to IP68.

- Works as a puller or a pusher fan. All glass-filled nylon construction. Includes (4) 90° mounting feet.
- Motor: 130 watt heavy duty
- Airflow at 0" static: 540 CFM
- Depth: 2.48" • Amp draw: 8.1



Electric Fan Mounting Kit

Fans are set up as "puller" units, mounted behind the radiator. By flipping blades, reversing wires, and mounting in front of radiator, fans will operate in "pusher" configuration. Each unit includes a mounting kit.



- ALL30085\$5.99

Overflow Tanks

Stainless steel tank captures coolant overflow & recirculates it to the radiator. Machined alum cap twists into the filler neck and seals with an O-ring. Inlet/outlet fittings accept 1/4" dia. hose. Measurements are of tank body; add 2" for overall length.

- 2" x 13" Long TankALL36150\$42.99
- 2" x 15" Long TankALL36151\$43.99

Overflow Tanks w/Filler Neck

1 qt alum tanks are for cars with the manifold filler neck higher than the radiator top tank. Features include a heavy duty alum neck with a 1/8" NPT port for an overflow fitting, a 1/2" NPT bung on the bottom, for a supply, and a 1/4" NPT fitting on the ALL36116 and a 3/8" NPT on the ALL36115 for a return line.

- Welded-On BktALL36115\$76.99
- Separate BktALL36116\$69.99

Overflow Tanks

Mandated by most sanctioning bodies to prevent coolant from spilling on the racing surface.

- 1 QuartALL36112\$65.99
- 2 QuartALL36114\$65.99

Bushing for 5/8" Shaft

Required to use the Fan Freewheeler (ALL30078) on a 5/8" shaft.

- ALL99026\$7.99

Overflow Tank Bkts

Billet alum bkt mounts Jaz overflow tanks to 1-1/2" or 1-3/4" round tubing. Bkts are adjustable to any angle, for a wide variety of mounting options. Tank mounting holes are 1/4" dia.

- Mounts To 1-1/2" Dia. TubingALL14200\$17.99
- Mounts To 1-3/4" Dia. TubingALL14201\$17.99

Radiator Fin Tool Kit

It straightens and repairs damaged fins in most radiators, coolers, and air conditioning condensers. Repairing damaged fins provides better airflow through core increasing cooling ability. Six interchangeable heads 13, 15, 16, 17, 18 and 20 fins per inch.

- ALL10680\$12.99



Champion Series 10"

Lowest profile high perf 10" reversible on the market. 130 watt sealed motor tested in accordance with DIN EN 60529, dust and water proof to IP68. Quiet, reversible S-blade design - works as a puller or a pusher fan. All glass-filled nylon construction. Includes (4) 90° mounting feet and nylon tie kit.

- Motor: 130 watt heavy duty
- Airflow at 0" static: 950 CFM
- Depth: 2.48" • Amp draw: 7.9



Champion Series 12"

Highest performing 12" reversible on the market. 225 watt sealed motor tested in accordance with DIN EN 60529, dust and water proof to IP68. Quiet, reversible S-blade design - works as a puller or a pusher fan. All glass-filled nylon construction. Includes (4) 90° mounting feet.

- Motor: 225 watt heavy duty
- Airflow at 0" static: 1,565 CFM
- Depth: 3.19" • Amp draw: 18



Champion Series 14"

Lowest profile 14" reversible on the market. 225 watt sealed motor tested in accordance w/DIN EN 60529, dust & waterproof to IP68. Quiet, reversible S-blade design puller or a pusher fan. All glass-filled nylon construction. Includes (4) 90° mounting feet.

- Motor: 225 watt heavy duty
- Airflow at 0" static: 2,135 CFM
- Depth: 3.19" • Amp draw: 17.2



Champion Series 16"

Lowest profile perf 16" reversible on the market. 225 watt sealed motor tested in accordance w/DIN EN 60529, dust and waterproof to IP68. Quiet, reversible S-blade design puller or a pusher fan. All glass-filled nylon. Includes (4) 90° mounting feet.

- Motor: 225 watt heavy duty
- Airflow at 0" static: 2,170 CFM
- Depth: 3.19" • Amp draw: 17.7



V-Belts

Premium quality V-belts are perfect replacements for worn or weather-cracked belts.

- 31.5" V-Belt, W/PALL86120\$9.99
- 34" V-Belt, Crank to WPALL86121\$9.99
- 39" V-Belt, W/P And P/SALL86122\$9.99
- 41" V-Belt, Crank/WP/Block Mot P/S PumpALL86123\$9.99
- 42" V-BeltALL86124\$10.99
- 44" V-Belt, Crank/WP/Head Mt P/S PumpALL86125\$10.99



Upper Radiator Mount Kit

Channel rests on top of the core and 2 flat alum straps may be bolted or welded to the channel. Hook the steel springs into provided hole and connect to a lower chassis location. Kit includes channel (2" x 21.5"), two straps (1" x 11.5") and two 17" springs.

- Upper Radiator Mount KitALL30121\$53.99
- Spring OnlyALL30122\$10.49
- Channel OnlyALL30123\$10.49



Upper Radiator Support

They can be used with almost any chassis. Hole is 3/16".

- ALL30120\$6.39



Universal Radiator Mount Kit

Aluminum side supports fasten around tanks to cradle radiator and the brackets can be drilled for a variety of mounting options. Side supports require notching to clear GM and Ford lower outlet fitting.

- ALL30155\$98.99



Composite Race Fans

It features a universal center hub made from 6061-T6 Alum and composite blades for a significant decrease in weight over traditional steel fans. Our blades are manufactured using extremely durable high-impact and high-temp fiber reinforced Zytel.



6 Blade Race Fans

- 17"RFN64-1700-006 ..\$360.00
- 19"RFN64-1900-006 ..\$360.00

4 Blade Race Fans

- 17"RFN64-1700-004 ..\$265.00
- 19"RFN64-1900-004 ..\$265.00

3 Blade Race Fans

- 17"RFN64-1700-003 ..\$217.50
- 19"RFN64-1900-003 ..\$217.50

2 Blade Race Fans

- 17"RFN64-1700-002 ..\$170.00
- 19"RFN64-1900-002 ..\$170.00

Blade Only

- 17"RFN62-1700-000 ..\$40.00
- 19"RFN62-1900-000 ..\$40.00

Hubs

6061-T6 Aluminum. 3/8" and 5/16". Made in the USA. Patent Pending.

- 3/4"RFN60-5000-750 ..\$75.00
- 5/8"RFN60-5000-625 ..\$75.00



Hardware

- Hardware Kit for 1 BladeRFN61-1000-000 ..\$7.50
- 1/4" Nas Bolt X 1/2" LongRFN12-0408-000 ..\$1.50
- 1/4" Jet NutRFN18-0250-000 ..\$0.90
- 1/4" Thin WasherRFN22-0250-000 ..\$0.07

FLUIDYNE

Ultra Thin Line 12V Electric Fan

- Low voltage draw
- Sealed motor

Air Flow Current
CFM Amperes

- Part # FLUFRP34211 11" Dia 1075 9.3 Pusher \$99.95

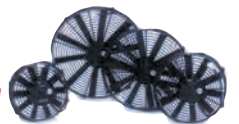

4 Blade Steel Fans

All Steel fans for high RPM and have a universal bolt pattern with a 5/8" pilot hole.

- 15"ALL30104\$37.99
- 18"ALL30105\$38.99
- 19"ALL30101\$39.99



6 Blade Fans

Heavy-duty, 6-blade fans are available in alum or steel. Universal bolt pattern with a 5/8" pilot hole.

- Diam. Aluminum Blades
- 15"ALL30096\$35.99
- 17"ALL30097\$38.99



Diam. Steel Blades

- 15"ALL30102\$29.99
- 17"ALL30103\$31.49
- 18"ALL30100\$32.99

Molded Nylon Fans

Lightweight, 6-blade fans are economical and very durable. Universal bolt pattern with a 5/8" pilot hole.

- 14"ALL30091\$19.99
- 15"ALL30092\$19.99
- 16"ALL30093\$19.99
- 17"ALL30094\$19.99
- 18"ALL30095\$19.99



Fan Spacer Kits

Alum spacers include reducer bushing, four Allen bolts to secure spacer to water pump and four hex bolts with washers to secure fan to spacer.

- 0.5" Fan Spacer KitALL30180\$23.99
- 1" Fan Spacer KitALL30182\$24.99
- 1.5" Fan Spacer KitALL30184\$25.99
- 2" Fan Spacer KitALL30186\$27.99
- 2.5" Fan Spacer KitALL30188\$28.99
- 3" Fan Spacer KitALL30190\$29.99



Fan Spacers

- 1" Fan SpacerBRP1009\$27.00
- 1-1/2" Fan SpacerBRP1010\$30.63
- 2" Fan SpacerBRP1012\$31.91
- 2-1/2" Fan SpacerBRP1013\$34.39
- 3" Fan SpacerBRP1015\$35.60
- 3-1/2" Fan SpacerBRP1017\$36.24
- 4" Fan SpacerBRP1019\$39.32



North East Modifieds for SBC

(Complete SBC NE Mod front belt drive) ..JON 1056-S...\$987.06

SBC Serp. WP & PS w/HTD Oil Pump Drive System Pieces

CS Pulley Register	JONDH-5102-R	\$15.20
Crank Pulley	JONDH-5102-G	\$85.90
Billet Al 1/4" Split V-Spacer	JONDH-3102-WC-1/4	\$19.90
3/8" dia 2.25" long al bolts	JONSK-2109-M2	\$12.90
1/2" Dual dowel assy spacer	JONSP-6103-WC-C-1/2	\$15.90
Belt Guide	JONBG-6108-WC	\$10.40
HTD OP Drive Pulley	JONCS-6102-WC-22	\$63.95
Dowel Pin	JONDP-2109-A	\$3.05
End Cap with Large Nut	JONEC-6111-WC-Nx1/2	\$28.26
Water Pump Pulley	JONWP-5104-WC-5-DS	\$134.90
Shims and Bushings	JONWP-2109-MK	\$18.19
HD Serpentine WP Belt	JON6PK-695HD	\$27.90
PS Bracket	JONPSH-8001-BB	\$73.40
PS Pump	JONPS-9008-AL	\$205.90
PS Pulley	JONPS-5106-B-4.500	\$68.15
HD Serpentine PS Belt	JON5PK-735	\$14.79
HTD Oil Pump Pulley	JONOP-6103-38-11/4	\$78.65
HTD Oil Pump Belt	JON600-20HD	\$31.30
SBC HTD Alternator Kit	JON2041-RA	\$556.79



JON1056-S with JON2041-RA

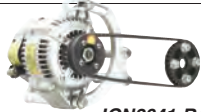

SBC Radius Tooth Alternator Kit..2041-RA

JON2041-RA

45 amp, 1-Wire Alternator	JONAL-9101-B-NS	\$249.90
24 Tooth Alt. Pulley	JONAL-9105-24-A	\$62.90
32 Tooth Drive Pulley	JONWP-9104-32	\$52.40
Belt Guide	JONBG-9108-W	\$14.60
Radius Tooth Belt	JON672-10HD	\$16.78
Alternator Bracket	JONAL-9100-CL-B	\$68.15
Rear Alternator Support	JONAL-9100-CL-HM	\$47.15
Mounting Kit	JONAL-9100-CL-BK	\$15.65
Switch	JONSW-9100-A	\$12.48

Use kit JON2040 for V-Belt Setup



Synthetic Power Steering Fluid

This crystal clear, fully synthetic power steering fluid is capable of exceeding all others in overall performance. The steering system's demands of the fluid with high pump flow rates and extreme temperatures make this fully synthetic a top choice to provide the driver with a confident and consistent feel from start to finish of a race. This fluid will not develop foam, causing cavitation of the pump nor will it break down during long green flag runs at full operating temperatures.



JONPS-8009-32S.....\$11.55

North East Modifieds for BBC

(Complete BBC NE Mod front belt drive) ..JON1055-S...\$988.48

BBC Serp. WP & PS w/HTD Oil Pump Drive Sys Pieces

CS Pulley Register	JONDH-5102-R	\$15.20
Crank Pulley	JONDH-5102-G	\$85.90
Bolt Kit	JONSK-2109-H	\$9.41
2 Crank Pulley Spacers	JONSP-6103-WC-C-1/2	\$15.90
Belt Guide	JONBG-6108-WC	\$10.40
HTD OP Drive Pulley	JONCS-6102-WC-22	\$63.95
Dowel Pin	JONDP-2109-A	\$3.05
End Cap with Large Nut	JONEC-6111-WC-Nx1/2	\$28.26
Water Pump Pulley	JONWP-5104-WC-5-DS	\$134.90
Shims and Bushings	JONWP-5104-MK	\$18.90
HD Serpentine WP Belt	JON6PK-695HD	\$27.90
PS Bracket	JONPSH-8001-BB	\$73.40
PS Pump	JONPS-9008-AL	\$205.90
PS Pulley	JONPS-5106-B-4.500	\$68.15
HD Serpentine PS Belt	JON5PK-690HD	\$19.90
HTD Oil Pump Pulley	JONOP-6103-38-11/4	\$78.65
HTD Oil Pump Belt	JON640-20HD	\$32.46
BBC HTD Alternator Kit	JON2031-RA	\$544.01



BBC Radius Tooth Alternator Kit..2031-RA

JON2031-RA

45 amp, 1-Wire Alternator	JONAL-9101-B-NS	\$249.90
24 Tooth Alt. Pulley	JONAL-9105-24-A	\$62.90
32 Tooth Drive Pulley	JONWP-9104-32	\$52.40
Belt Guide	JONBG-9108-W	\$14.60
Radius Tooth Belt	JON680-10HD	\$16.89
Alternator Bracket	JONAL-9100-CL-B-BB	\$73.40
Rear Support Bracket	JONAL-9100-CL-BM-BB	\$28.90
Mounting Kit	JONAL-9100-CL-BK-BB	\$15.65
Switch	JONSW-9100-A	\$12.48

Use kit JON2030 for V-Belt Setup

Small Block Chevy Mid-Mount Alternator Bkts

Mounts from short water pump, mounts on left or right side of water pump.



45 Amp Alternator	JONAL-9100-CL-B	\$68.15
65 and 80 Amp	JONAL-9100-CL-C	\$61.34
Rear Support	JONAL-9100-CL-HM	\$47.15
Mounting Kit	JONAL-9100-CL-BK	\$15.65
GM Alternator	JONAL-9100-CL-GM	\$73.90
GM Mounting Kit	JONAL-9100-CL-GM-BK	\$15.65

JON WPM-9101-C

JON WPM-9101-A

Big Block Chevy Mid-Mt Alternator Bkts

Mounts from short water pump, mounts on left or right side of water pump.



45 Amp Alternator	JONAL-9100-CL-B-BB	\$73.40
65 and 80 Amp	JONAL-9100-CL-C-BB	\$66.06
Rear Support	JONAL-9100-CL-BM-BB	\$28.90
Mounting Kit	JONAL-9100-CL-BK-BB	\$15.65
GM Alternator	JONAL-9100-CL-GM	\$73.90
GM Mounting Kit	JONAL-9100-CL-GM-BK	\$15.65

JON WPM-9101-C

Adjusting Rods

JONADR-9100-6.....6"	
JONADR-9100-6.5.....6.5" SB	
JONADR-9100-8.....8" BB	
	\$48.20



Circle Track, Crate:

(Complete Chevy Crate Belt Drive w. Alternator kit)	JON1441-AR-CE	\$1498.13
SBC Alum. PS to accept Remote Tank & Mini 1-Wire Alt w. Bkt Pulleys and Belts	JON1441-AL-CE	\$1377.01
SBC Alum. SWP, PS Pump w. Built-In Alum. Reservoir, Bkt, Pulleys and Belts	JON1004-AR-CE	\$929.15
SBC Alum. SWP, PS Pump to accept Remote Reservoir, Bkt, Pulleys and Belts	JON1004-AL-CE	\$808.03
(Pulleys, Belts & PS Bracket, Chevy crate) 6500 RPM	JON1004-S-CE-6500	\$371.04
(Pulleys, Belts & PS Bracket, Chevy crate) 7500 RPM	JON1004-S-CE-7500	\$371.04
(SBC Stand alone Water Pump Belt Drive, Chevy Crate)	JON1035-S-CE	\$226.17
(Complete Ford Crate Belt Drive w. Alt. kit)	JON1565-AR-CE	\$1502.63
SBF Alum. PS Pump to accept Remote Reservoir Bracket Pulleys and Belts	JON1005-AL-CE	\$748.08
(Pulleys, Belts & PS Bracket, Ford crate)	JON1005-S-CE	\$543.74
SBC Serp. WP & PS Drive with Steel SWP, Remote Tank PS Pump	JON1004-AL-DRT	\$718.13
SBC Serp. WP & PS Drive with Steel SWP, Integrate, Alum Tank PS Pump	JON1004-AR-DRT	\$839.15
SBC Crate Engine WP, Power Steering and Alternator Drive	JON2441-AR-CE	\$1799.00
SBC Serp. WP & PS Drive and Radius Tooth Alt Kit with Steel SWP, Remote Tank PS Pump & 55/70 amp 1-wire Alt.	JON1441-AL-DRT	\$1287.01
SBC Serp. WP & PS Drive and Radius Tooth Alt Kit with Steel SWP, Integrate, Aluminum Tank PS Pump & 55/70 amp 1-wire Alt.	JON1441-AR-DRT	\$1408.13

CRATE 602



JON 1004-AL-DRT (Cast Iron WP)
JON 1004-AL-CE (Aluminum WP)



JON2441-AR-CE

Circle Track, Open Motors:

JON 72=7200 Max RPM, 75, 78, 80+ also available. (Pulleys, Belts and PS Bracket, Chevy)	JON1004-S-75	\$403.83
(Pulleys, Belts and PS Bracket, Ford)	JON1005-S-75	\$533.78



Small Block Ford Kits

Alum PS Pump to accept Remote Reservoir, Bkt, Pulleys, & Belts
 JON1005-AL-CE **\$748.08**

PS Pump w. Built-In Alum Reservoir, Bkt, Pulleys, & Belts
 JON1005-AR-CE **\$869.20** **JON1005-AL-CE**

55 Amp Alternator Drive Kit, Mounts from WP
 JON2065-RA **\$548.59**

WP, PS, and Alternator Complete Drive System,
 WP sold separately (Remote PS Tank)
 JON1565-AL-CE **\$1280.00**

WP, PS, and Alternator Complete Drive System, **JON1565-AL-CE**
 WP sold separately (Built-In PS Tank)
 JON1565-AR-CE **\$1502.63**

LS WP Drive Kit w. HP WP, Serp. Pulleys, Hardware, and Belts
 JON1020-LS **\$749.31**

LS Drive Kit w. HP WP and PS Pump with Aluminum Tank
 JON1006-LS **\$1245.78**

LS Alt Kit w. 55/75 Amp 1-Wire Mini Alternator
 JON2046-LS **\$550.65**

Billet Aluminum Water Pump Spacers

- 1/8" Small Block Billet Alum Water Pump Spacers..JONWP-9104-1/8-SB **\$.17.01**
- 1/4" Small Block Billet Alum Water Pump Spacers..JONWP-9104-1/4-SB **\$.26.01**
- 3/8" Small Block Billet Alum Water Pump Spacers..JONWP-9104-3/8-SB **\$.28.90**
- 1/2" Small Block Billet Alum Water Pump Spacers..JONWP-9104-1/2-SB **\$.26.01**
- 1/4" Big Block Billet Alum Water Pump Spacers..JONWP-9104-1/4-BB **\$.34.90**
- 3/8" Big Block Billet Alum Water Pump Spacers..JONWP-9104-3/8-BB **\$.31.41**
- 1/2" Big Block Billet Alum Water Pump Spacers..JONWP-9104-1/2-BB **\$.31.41**

Replacement Pulleys & Belts

SB Kit 1004 7600

- 3.250" diameter, 1-1/8" bore, serpentine, cs pulleyJONCS-5102-D..... **\$59.75**
- 4" diameter, 1.135" offset, 6-groove serp. wp pulleyJONWP-5104-C-4..... **\$71.30**
- 4.500" diameter, 6-groove, press fit, serp ps pulleyJONPS-5106-B-4.500..... **\$68.15**
- 33.465" long, 5-groove serp. beltJON5PK-850..... **\$16.79**

SB Kit 1004 6200

- 3.750" diameter, 1-1/8" bore, serpentine, cs pulleyJONCS-5102-F..... **\$68.15**
- 4" diameter, 1.135" offset, 6-groove serp. wp pulleyJONWP-5104-C-4..... **\$71.30**
- 4.500" diameter, 6-groove, press fit, serp ps pulleyJONPS-5106-B-4.500..... **\$68.15**

BBC Modified Kit 1055

- 4.000", dual dowel (WC), serp, cs pulleyJONDH-5102-G..... **\$85.90**
- 5.0" rear, 3-7/8" front double serp wp pulleyJONWP-5104-WC-5-DS.. **\$134.90**
- 4.500", 6-groove, press fit, serp ps pulleyJONPS-5106-B-4.500..... **\$68.15**
- 27.362" long, 5-groove serp. beltJON6PK-695HD **\$27.90**

Late Model Kit

1020 Kit

- 4.000", dual dowel (WC), serp, cs pulleyJONDH-5102-G..... **\$85.90**
- 5.0" diameter, 2.320" offset, 6-groove serp. wp pulleyJONWP-5104-WC-5.0 **\$93.35**
- 27.362" long, 5-groove serp. beltJON5PK-695HD **\$19.90**

1035 kit

- 4.250", dual dowel (WC), serp, cs pulleyJONDH-5102-H..... **\$75.90**
- 4.5" diameter, 2.320" offset, 6-groove serp. wp pulleyJONWP-5104-WC-4.5 **\$86.00**
- 27.283" long, 5-groove serp. beltJON5PK-690HD **\$19.90**

Dirt Modified like UMP, USMTS, IMCA ect.

(SBC Stand Alone Serpentine WP Drive)

JON1020-S..... **\$325.00**

(SBF Stand Alone Serpentine WP Drive)

JON1026-S..... **\$385.59**

(Oil Pump Drive Pulleys, Bell housing mounted)

JON2004-RA **\$349.57**

Kit 1020 Add-on PS kit with Alum PS Pump

and Built-In Alum Tank

JON1020-PS **\$600.22**



JON1020-S JON1026-S

Crate & Late Model Water Pump Drive Kit

Lightweight Aluminum Serpentine Crankshaft to Water Pump **JON1020-S**

- 20% ReductionJON1020-S..... **\$325.00**
- 6% Reduction (Crate)..JON1035-S-CE **\$226.17**

3 Blade Aluminum Hustler Fans

A True Racing Fan Blade Designed For High RPM Racing Engines. 3 Blade Fans Provide Improved Performance by not Stalling out at High RPM's and Creating Un-Wanted Drag and Power Loss on the Engine.

- 15" FanJONWP-9104-15-H3 **\$.145.56**
- 17" FanJONWP-9104-17-H3 **\$.145.56**

- 2" Fan Spacer Kit.....JONWP-9104-FS2 ... **\$.59.67**
- 3" Fan Spacer Kit.....JONWP-9104-FS3 ... **\$.62.66**

Radius Tooth HTD

10mm Wide, 8mm Pitch

- 18.898" LongJON480-10HD **\$13.01**
- 22.047" LongJON560-10HD **\$14.95**
- 22.677" LongJON576-10HD **\$15.38**
- 23.307" LongJON592-10HD **\$15.43**
- 23.622" LongJON600-10HD **\$15.61**
- 23.937" LongJON608-10HD **\$15.82**
- 24.567" LongJON624-10HD **\$15.84**
- 24.882" LongJON632-10HD **\$16.08**
- 25.197" LongJON640-10HD **\$16.23**
- 25.827" LongJON656-10HD **\$16.45**
- 26.457" LongJON672-10HD **\$16.78**
- 26.772" LongJON680-10HD **\$16.89**
- 27.402" LongJON696-10HD **\$21.20**
- 28.346" LongJON720-10HD **\$17.12**
- 28.976" LongJON736-10HD **\$17.29**
- 30.551" LongJON776-10HD **\$15.72**
- 33.701" LongJON856-10HD **\$17.75**

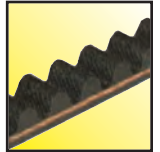

Radius Tooth HTD

30mm Wide, 8mm Pitch

- 23.622" LongJON600-30HD **\$46.83**
- 24.567" LongJON624-30HD **\$43.34**
- 23.937" LongJON632-30HD **\$48.22**
- 25.197" LongJON640-30HD **\$48.69**

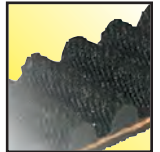

Radius Tooth HTD

20mm Wide, 8mm Pitch

- 22.047" LongJON560-20HD **\$29.91**
- 22.677" LongJON576-20HD **\$30.76**
- 23.622" LongJON600-20HD **\$31.30**
- 23.937" LongJON608-20HD **\$28.55**
- 24.567" LongJON624-20HD **\$31.84**
- 24.882" LongJON632-20HD **\$31.84**
- 25.197" LongJON640-20HD **\$32.46**
- 25.827" LongJON656-20HD **\$32.90**
- 26.457" LongJON672-20HD **\$30.21**
- 26.772" LongJON680-20HD **\$30.42**
- 30.551" LongJON776-20HD **\$31.42**
- 31.496" LongJON800-20HD **\$33.28**

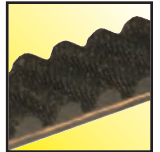

Serpentine

5 & 6 Groove Belts 20mm Wide, 8mm Pitch

- 27.165" 5-Groove..JON5PK-690HD .. **\$19.90**
- 27.362" 5-Groove ..JON5PK-695HD .. **\$19.90**
- 33.465" 5-Groove ..JON5PK-850HD .. **\$18.65**
- 35.039" 5-Groove ..JON5PK-890HD .. **\$18.65**
- 37.008" 6-Groove ..JON6PK-940 **\$25.11**

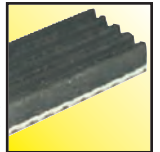

Pulley Installer / Removal Tool

Tool to remove and install press on power steering pulleys.

JONPSR-7005-A..... **\$51.84**

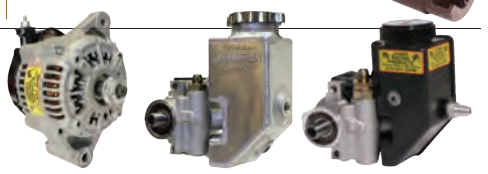

JONAL-9101-B-NS JONPS-9008-AL-AR JONPS-9008-AL-R

Alternators

- 55 Amp, Single Wire Alternator, Switchless.....JONAL-9101-B-NS **\$249.90**
- 55 Amp, 1-Wire, Switchless, 16+ Volt Adjustable Reg.JONAL-9101-B-NS-A..... **\$269.91**
- 24 Tooth, Rad. Tooth, Alt Pulley, Belt Guides, .590 BoreJONAL-9105-24-A **\$62.90**
- 55 Amp, SBC SWP Alternator Bracket AssemblyJONAL-9100-CL-BK **\$15.65**
- High Amp Switch to protect alt when charging the systemJONSW-9100-A **\$12.48**

PS Pumps

- (Alum PS Pump with Built-in Alum. Tank)JONPS-9008-AL-AR... **\$359.90**
- (Alum PS Pump with Built-in Plastic Tank)JONPS-9008-AL-R **\$277.12**
- (Alum PS Pump, Accepts Remote Tank)JONPS-9008-AL **\$205.90**
- (Alum Remote Reservoir for PS Pump, Mounts to Frame)JONPS-8101-A..... **\$89.90**
- (Alum Remote Reservoir for PS Pump, Mounts to Firewall) ..JONPS-8101-B..... **\$94.90**
- SBC Head mount PS Bracket for PS-9008-AL-ARJONPS-8001-SB-R..... **\$85.95**



JONPS-9008-AL JONPS-8101-A JONPS-8101-B

Serpentine Pulleys

3.5" Diameter Upper Serp. Pulley
BRP950.....\$61.46
4.25" Diameter PS Serp. Pulley
BRP951.....\$61.46
2.6" Diameter Lower Serp. Pulley*
BRP952.....\$73.74
3.0" Diameter Lower Serp. Pulley SBC
BRP952-2.....\$73.74
Lower Pulley Spacer
BRP953.....\$20.54



Serpentine Belts

* Provides 35% Reduction for small block Chevys
17% Reduction substitute BRP952-2 for BRP952.

36" S.B. Serpentine Belt for Std. Pulleys.....BRP949.....\$30.18
36-1/2" when using BRP268 Mount.....BRP949-1.....\$40.14
37" S.B. Serpentine Belt for (-2) Pulleys.....BRP949-2.....\$31.50

7" Billet Double Groove Top Pulley

Hard coated, Chevy or Ford. Double groove. 15% reduction.
BRP1003.....\$104.52

5-1/2" Billet Double Groove Lower Pulley

SBC.....BRP1006.....\$47.92
BBC.....BRP1006B.....\$49.16

Crate SBC Serpentine Pulley Kit

Crate SBC Serpentine Pulley Kit Complete w/Alt. & Power Steering Pump & Red Bkts, 17% Reduction. All Pulleys and Belts...BRP1442BK...\$694.84

Kit Includes:

Serpentine Pulley
BRP952-2.....\$73.74

Pulley Spacer
BRP953.....\$20.54

Serpentine Belt
BRP949-3.....\$35.05

Power Steering Mount Assembly
BRP268.....\$45.46

Pump and Serpentine Pulley
BRP581.....\$209.49

SBC Alternator Mount
BRP9068.....\$83.70

Serpentine Pulley WP/3 Rib Alt.
BRP946.....\$72.90

3 Rib Serpentine Belt
BRP947.....\$24.86

Alternator with Serpentine Pulley
BRPP0W8172-172...\$211.28

Serpentine Pulley Idler Kit

It bolts onto the lower block mounts, not the water pump and other accessories to eliminate shimming due to varying bolt on components. It comes with different spacer combinations to allow the use of power steering mounts, motor plates, single sided engine mounts and dry sump pumps.
BRP9429.....\$217.62

Lower Pulley Hex Drive

Works Great with BRP952, 952-1, 952-2, to help turn engine over when setting valves or whistle testing.
BRP9149.....\$18.00

Power Steering Tank w/Bracket

Lightweight aluminum tank is for race cars requiring an external power steering fluid reservoir. Tank has -6 AN fitting on side and -10 AN fitting on bottom. Tank is 6" tall and 3-1/2" in diameter Overall height is 8-1/2".
ALL36121.....\$71.99

Economy Power Steering Tank w/Bkt

Aluminum tank has no internal baffles, and is 8" tall by 3" in dia with a -6 return fitting on the side and a -10 fitting on the bottom. A mounting bkt for 1-3/4" round tubing is included.
ALL36130.....\$51.99

Power Steering Tank w/Bkt

BRP563B.....\$94.80

Power Steering Pump

Pump w/ 3/8" pulley.....PRO003.....\$199.95
Pump only.....PRO002.....\$154.95
3/8" pulley only.....PRO005.....\$46.95

SBC- Late Model GM Pump

w/18° & 23° Cyl. Head

It mounts a late-model, small-style GM power steering pump (with remote reservoir) or Sweet-type pumps to the driver's side cyl head of a SBC. Manufactured from 3/8" 6061-T6 alum, then blue anodized.
MOR63897.....\$97.17

Power Steering Pump

Dry Sump Pump Mt Adapter Kit....SWE325-30057..\$41.75

Power Steering Pump Bkt Kits SBC

Alum brackets will mt power st pumps on circle track cars. Their mount pump to cyl head...ALL48500.....\$44.99

Power Steering Pumps

PSI ratings are max available pressure, lower pressure and flow pumps are recommended for street use. In most racing apps a 1000 psi, 3 GPM pump works well. When wheel loads are extremely high and desert off-road conditions a higher pressure pump is necessary. Supply hoses going into the pump should be 2 ft. or less to avoid pump cavitation. Alum pumps are 1 lb. lighter than steel.

1450 psi	Aluminum	Steel
No Pulley.....	SWE305-60630	\$211.90 SWE305-70630..\$205.85
w/SW 7/16 Pulley.....	SWE305-60631	\$241.00 SWE305-70631..\$241.00
w/SW 1/2 Pulley.....	SWE305-60632	\$243.50 SWE305-70632..\$241.00
w/SW 7-1/2 Pulley.....	SWE305-60633	\$268.50 SWE305-70633..\$263.00
w/SW 3/8 Hex Drive.....	SWE305-60634	\$258.75 SWE305-70634..\$264.40
w/Serpentine Pulley.....	SWE305-60637	\$263.00 SWE305-70637..\$264.40
w/ 6 bolt CV Hub.....	SWE305-60638	\$255.30 SWE305-70638..\$255.50
w/ 33T HTD Pulley.....	SWE305-60639	\$292.10 SWE305-70639..\$285.00

1300 psi	Aluminum	Steel
No Pulley.....	SWE305-60330	\$211.90 SWE305-70330..\$204.50
w/SW 7/16 Pulley.....	SWE305-60331	\$241.00 SWE305-70331..\$241.00
w/SW 1/2 Pulley.....	SWE305-60332	\$243.50 SWE305-70332..\$241.00
w/SW 7-1/2 Pulley.....	SWE305-60333	\$268.50 SWE305-70333..\$263.00
w/SW 3/8 Hex Drive.....	SWE305-60334	\$258.75 SWE305-70334..\$264.40
w/Serpentine Pulley.....	SWE305-60337	\$263.00 SWE305-70337..\$263.00
w/ 6 bolt CV Hub.....	SWE305-60338	\$255.30 SWE305-70338..\$255.50
w/ 33T HTD Pulley.....	SWE305-60339	\$292.10 SWE305-70339..\$284.65

1000 psi Sportsman	Aluminum	Steel
No Pulley.....	SWE305-60230	\$211.90 SWE305-30230..\$160.65
w/SW 7/16 Pulley.....	SWE305-60231	\$241.00 SWE305-30231..\$177.10
w/ 3/8 Hex Drive.....	SWE305-60234	\$258.75
w/ 33T HTD Pulley.....	SWE305-60239	\$292.10

Steering Quick Disconnect

High quality disconnect features multi spline design for a more accurate fit. Bolts to Sweet, Profile or GME steering box.
Sprint Quick Release....SWE801-70005...\$90.45
Coupler Only.....SWE316-70009...\$21.85

Steering Quick Release

3/4" Weld On Aluminum Quick Release
SWE801-70004.....\$90.45

Steering Disconnect

Button Style
Fits 3/4" shaft.....BRP188 ..\$36.70
Fits 5/8" shaft.....BRP186 ..\$36.70
Splined for Profile.....BRP190 ..\$50.67
Rim Type
Fits 3/4" shaft.....BRP178 ..\$44.21
Fits 5/8" shaft.....BRP177 ..\$44.21
Splined for Profile.....BRP179 ..\$46.69

Multi Splined Quick Release Steering Disc.

Complete assembly fits Nields/Profile/Lee Boxes
BRP2129.....\$68.28

5/8" Weld On.....BRP2127.....\$59.00
3/4" Weld On.....BRP2128.....\$59.00

Push Lock Quick Release Hubs

The new Push Lock quick release system. No need to pull on the rim to install- just push the steering wheel on. The quick release automatically locks every time! All feature 1/4" and 5/16" steering wheel mounting holes. Housing is machined from billet 6061 alum.

5/8" shaft weld on Push Lock quick release hub.....BRP160.....\$70.09
3/4" shaft weld on Push Lock quick release hub.....BRP161.....\$70.09
Splined shaft for center steer Push Lock quick release hub (fits Profile/Nields/Lee steering boxes).....BRP162.....\$66.37

Thick Steering Wheel Spacers

Designed to go between steering wheel and quick release hub.

Size	Red	Black	Price
1/2"	BRP189-50		\$14.69
1"	BRP189-100	BRP189-100BK	\$15.94
1-1/2"	BRP189-150	BRP189-150BK	\$18.40
2"	BRP189-200	BRP189-200BK	\$20.87

Longacre

Steering Wheel Spacers
3/4".....LON56703..\$12.75
1-3/4".....JOE10704-G.....\$20.95

JOES Steering Wheel Hook

1-1/2".....JOE10702-G.....\$20.95
1-3/4".....JOE10704-G.....\$20.95

Steering Wheel Extension

Alum. steering wheel extensions fit between steering wheel and quick disconnect. Perfect for adjusting the distance between driver and steering wheel. Complete with fasteners.

1" Thick.....ALL52310.....\$8.49
1" Thick.....ALL52312.....\$8.99
1-1/2" Thick.....ALL52314.....\$9.49
2" Thick.....ALL52316.....\$9.59

Free Moving Steering Box Mts

3" Bolt Spacing Non Binding Steering Box Mount (TEO Style).....BRP9303.....\$83.68
2-1/2" Bolt Spacing Non Binding Steering Box Mount (Used on Bicknell Cars)....BRP9298.....\$83.68



Circle Track Economy Steering Wheels

Aluminum structure/brushed silver. Solid spokes. Double rivets technology and U-Channel to increase safety. MPIAMST tech. Foam grip. Dirt friendly/washable. Hole pattern: 3 + 3 holes. (fits all 3 bolts quick release)

- Size ...Flat Dished ...Dished
- 15" ...MPI-DR-15 ...MPI-DMR-15...\$129.00
- 16" ...MPI-DR-16 ...MPI-DMR-16...\$129.00
- 17" ...MPI-DR-17 ...MPI-DMR-17...\$129.00



Dirt Late Model/Modified/BB Modified Concept Specific 10.75"

Aluminum frame. Bright orange stripes embedded on grip. Highest quality suede. Open upper part facilitates inserting and improve vision on dashboard. Flat bottom to facilitates entering and exiting the car.

- Dia: 10.75" • Weight: 0.87 lbs
- Dish depth - None • Grip section: 1.33" x 0.94"
- Spoke: 3 solid spokes
- MPI-GT-11-C\$209.00



Road Course/Track Days/UTV Concept Specific 12.75"

Bright orange stripe/marker embedded in sw body. Oval/extreme ergonomic grip. Highest quality suede. Hole pattern: 6 hole. Crossed orange stitching for unique look/durability. MPI Horn Button included.

- Dia: 12.75" • Weight: 2 lbs
- Dish depth: 1.25" • Spoke: 3 solid spokes
- MPI-GT-13-A\$199.99



Road Course/Formula/Sports Car Concept Specific 11.25"

Aluminum frame. Highest quality suede. Oval/extreme ergonomic grip. Flat bottom to facilitates entering and exiting the car. Hole pattern: European 3 hole.

- Dia: 11.25" • Weight: 1.25 lbs
- Dish depth - None
- Spoke: 3 solid spokes
- MPI-GT-11-A.....\$209.00



Quarter Midget 10.75"

Alum. Dirt friendly/washable. Covered in 3 different dirt friendly/washable. Synthetic materials: Lederfylon high-grip, orange synthetic, carbon synthetic. Hole pattern: 3 hole. Hand swen crossed orange stitching for unique look/durability. Slotted spoke for reduce weight. MPI Centerpiece included.

- Dia: 10.75" • Weight: 0.92 lbs
- Dish depth: 1.25"
- Round.....MPI-KQR-11 ..\$150.00
- Square.....MPI-KQS-11 ..\$185.00



Aluminum with Bump Grip

- 15" BlackLON56820\$65.07
- 17" BlackLON56825\$65.15



Smooth Grips Steel Steering Wheels

- 15" BlackLON56841\$44.20
- 17" BlackLON56851\$44.15



Alum Smooth Grip Steering Wheels

- 15" Black.....LON56801\$52.98
- 15" BlueLON56803\$52.98
- 15" RedLON56805\$52.98
- 17" Black.....LON56811\$52.94
- 17" BlueLON56813\$35.70
- 17" Red.....LON56815\$47.03



Kart Steering Wheels

13" or 14" diameter. LW alum. 14" wheels are uncoated & shot peened for good grip

Uncoated Aluminum

- 13" BlackLON56830...\$48.54
- 14" Ultra Light shot peenedLON56834...\$52.98
- 14" Ultra Light DrilledLON56835...\$74.98



"Fat" Grip Aluminum Steering Wheels

Thicker rim for a better grip and less wrist and arm strain. 15" dished aluminum wheel with black spokes.

- LON56809.....\$61.83



LW Steering Wheels



It is drilled to reduce weight and is available with a black anodized finish or bare aluminum. Dished wheels have a 2-1/2" dish.

- | | |
|-----------------------------|---------------------|
| Dished Aluminum | Dished Black |
| 13" ...JOE13513-A...\$82.95 | JOE13513-B \$83.95 |
| 14" ...JOE13514-A...\$82.95 | JOE13514-B \$83.95 |
| 15" ...JOE13515-A...\$82.95 | JOE13515-B \$83.95 |
| 16" ...JOE13516-A...\$89.95 | JOE13516-B \$91.95 |
| 17" ...JOE13517-A...\$93.95 | JOE13517-B \$94.95 |

- | | |
|-----------------------------|--------------------|
| Flat Aluminum | Flat Black |
| 13" ...JOE13533-A...\$82.95 | JOE13533-B \$83.95 |
| 14" ...JOE13534-A...\$82.95 | JOE13534-B \$83.95 |
| 15" ...JOE13535-A...\$82.95 | JOE13535-B \$83.95 |
| 16" ...JOE13536-A...\$89.95 | JOE13536-B \$91.95 |
| 17" ...JOE13537-A...\$93.95 | JOE13537-B \$94.95 |

Quarter Midget Steering Wheel

It is Anodized black and Shot Peened for a texture you can hold on to. Joe's machines the center section and pre-drills the mounting holes ensuring a centered wheel, improving feel and chassis feedback. 3 x 1/4" on a 1-1/2" Bolt Circle.

- JOE13505-B.....\$69.95



Longacre Steering Wheels Ultra LW Aluminum



- | | |
|------------------------------------|-----------------------|
| Uncoated Aluminum | |
| 15" - DRILLED - Dished | LON56837\$84.14 |
| 15" with Bump Grip - Dished..... | LON56822\$61.83 |
| 15" with Smooth Grip - Dished..... | LON56836\$52.98 |
| 15" - DRILLED - Flat | LON56866\$84.14 |
| 14" - DRILLED - Dished | LON56835\$74.98 |
| 14" with Smooth Grip - Dished..... | LON56834\$52.98 |
| Uncoated Black Aluminum | |
| 15" - DRILLED - Dished | LON56838\$84.14 |
| 15" - DRILLED - Flat | LON56867\$84.14 |
| 14" - DRILLED - Dished | LON56833\$84.14 |

Steering Wheels Outlaw



- 1 lb. lighter than coated.
- 13" Flat OutlawSWE611-70131\$69.50
- 13" Dished OutlawSWE611-70132\$73.00
- 15" Flat OutlawSWE611-70152\$73.00
- 15" Dished OutlawSWE611-70151\$73.00
- 17" Flat OutlawSWE611-70171\$73.00
- 17" Dished Outlaw.....SWE611-70172\$73.00

Steering Wheels

Alum w/soft rubber finger grips. 3 1/2" dish.

- 17" Dished Aluminum ..SWE601-70172
- 17" Flat Aluminum.....SWE601-70171
- 15" Dished Aluminum ..SWE601-70152
- 15" Flat Aluminum.....SWE601-70151
- 13" Flat Aluminum.....SWE601-70131
- 13" Dished Aluminum ..SWE601-70132\$100.90



Steering Pads

6" dia, 2" thick high density foam covered in vinyl. Velcro loops wrap around wheel spokes. In 3 or 4 spoke design. Colors: Black Only.

- 6" Dia 3 Spoke KIR00001..\$16.99
- 4.5" Dia 3 Spoke KIR00031 ..\$16.99



Sprint/Midget Center Steering Pad Black

- Colors: Black (Only)
- KIR00021 ..\$15.99



Steering Wheel Pad Std (Spoke-Down)

We hope you never crash your car hard enough to hit your head on the steering column, but just in case, think safety and get a Joe's Steering wheel pad. It not only makes your race car safer, it looks cool too. Made with high-density foam, Velcro straps and measures 2-1/2" thick.

- JOE13650.....\$41.95

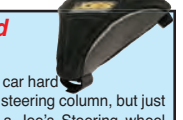



Steel Steering Box

Profile's Steel Gear has a 40 year+ winning history in Modified and Sprint Car. Aluminum Side Tubes. Forged billet sector shaft. Recirculating Ball Screw and Rack Piston assembly for precise steering. Rotary Activated Spool Valve Technology for quick steering response. Forged Sector Gear Shaft. Needle roller and trust bearings used throughout gear.

Steel 14:1..PRO001..\$742.95

Replacement Fittings

Profile Steel Steering Gear Fitting. Set 1-Pressure 1-Return. PROFITTING2. \$29.73



Billet Aluminum Steering Box

Super Lightweight Billet Aluminum Steering Box is made from all new materials, not rebuilt core boxes.

9:1 ratio 30 valvePROPR91230BM.....\$1586.25
 1/2 box 9:1 ratio 30 valve.....PROPR91230BM-1/2.....\$1586.25
 9:1 ratio 50 valvePROPR91250BM.....\$1586.25
 1/2 box 9:1 ratio 50 valvePROPR91250BM-1/2.....\$1586.25



Replacement Fittings

Fittings Set for Billet Aluminum Steering Gear 1-Pressure and 1-Return PROFITTING1. \$26.10



MOROSO

Power Steering Tanks

Built in bracket allows convenient mounting on a panel. -6 AN inlet on the right side of the tank as you look at the tank to be mounted and a -10AN bottom outlet with an internal bubble. Includes a heavy duty vented screw on cap
 w/Inlet Left Side...MOR63506\$91.74
 w/Inlet Right Side...MOR63507\$91.74



Power Steering Reservoir

PS Reservoir Panelfast Mount fits Teo/BRP/Troyer
 ART100506....\$125.50



Power Steering Reservoir

Steering Box Mount Clamp On
 ART100504\$152.95



Shaft Collars

They are available with I.D. measurements from 3/4" thru 1-1/4". May be used to mt a steering shaft, or a sway bar against the sway bar bolt.

3/4"ALL52140.....\$11.99
 7/8"ALL52142.....\$12.29
 1"ALL52144.....\$12.99



Steering Shaft Tubing

Seamless D.O.M. tubing, 3/4" dia with .120" wall thickness, is used to connect steering wheel to the steering box or rack and pinion.

5 Foot.....ALL22190...\$19.99
 6 Foot.....ALL22191...\$21.99



"Double D" Steering Shafts

3/4" O.D. "Double D" steel shafts have 2 flats to retain stock steering joints. 2 indents must be drilled and tapped for set screw retention. 3 lengths are available.

24"ALL52175\$14.99
 30"ALL52176\$18.99
 36"ALL52177\$24.99



Steering Quickener Bracket

Mounts all popular steering quickeners including AFCO, Coleman, Howe and others. Bkt has 2 holes, spaced 1-3/4" apart, and may be welded to 1-1/2" or 1-3/4" dia. tubing.

ALL60028.....\$7.89



Collapsible Steering Shaft Assemblies

Steer a race car with complete confidence. When mounted in the engine bay, between steering box and firewall, the collapsible shaft will compress in the event of a frontal crash. The heavy wall, 1.140" dia tubular steel shaft has 3/4"-20 splines on both ends. The durable rubber boot keeps the sliding mechanism free of dirt and debris.

LongALL52170.....\$129.99
 ShortALL52171.....\$122.99



Steering Column Bkts

Stamped-steel bkts mount the steering column in any circle track car. Bkts are 3-3/16" wide and are available in 4 lengths. Adjustment slot fits 3/4" rod end.

2-1/2"ALL52120.....\$8.99
 8"ALL52124.....\$10.99
 10"ALL52126.....\$12.99



Flange Bearing

Self-aligning Flange Bearing has a .757" I.D. and installs in the firewall to accept the steering shaft. Complete with locking collar. Bearing allows shaft to angle up to 40°.

ALL52130.....\$14.99



Univ. Steering Joints

Designed specifically for race cars, They are strong and precise with "no slop." Compact, LW & durable, this universal joint is capable of 32 degrees of working angle. These U-joints have been NASCAR approved.

3/4" Smooth:

x 3/4" SmoothSWE401-50606 ..\$46.06
 x 5/8"-36 SplineSWE401-50607 ..\$49.05
 x 3/4"-48 SplineSWE401-50610 ..\$49.05
 x 13/16"-36 Spline SWE401-50611 ..\$49.05
 x 3/4"-36 SplineSWE401-50612 ..\$49.05
 x 9/16"-26 Spline ..SWE401-50613 ..\$49.05
 x 5/8"-36 SplineSWE401-50614 ..\$49.05
 x 3/4"-30 SplineSWE401-50615 ..\$49.05
 x 1"-48 SplineSWE401-50618 ..\$69.30
 x 3/4"-DD Spline ..SWE401-50619 ..\$64.43
 x 1"-DD SplineSWE401-50620 ..\$64.43
 x 3/4"-20 SplineSWE401-50621 ..\$49.05

5/8" Smooth:

x 5/8" SmoothSWE401-50808 ..\$46.06



Rack and Pinion

Integrated servo rack and pinion units are available in (10) ratios from 1-7/8"(slow) to 4" (quick). There are (9) different valves available from .185 (easy) to .300 (hard). Sweet Mfg. rack and pinion units are made in the USA with the finest available materials and each unit is hand assembled and tested for quality assurance.

Part #: 005-923343-250

005- 92 3 4 3 -250
 A B C D E

A.) Rack Speed

30 = 1-7/8" East Coast Modified
 40 = 2" East Coast Modified
 50 = 2-1/4" Pavement Late Model
 60 = 2-1/2" Pavement Late Model
 80 = 3" Pavement Late Model
 90 = 3-1/4" Dirt Late Model
 91 = 3-1/2" Dirt Late Model
 92 = 3-3/4" Dirt Late Model
 93 = 4" Dirt Late Model

B.) Center Distance

1 = 16-1/2" ASA/Dash Car
 2 = 17-1/4" Howe Chassis
 3 = 18-1/4" Port City / CJ
 Rayburn / Barry Wright / Troyer / Hamke / Masterbilt / Lefthander / Shaw / Rocket (Blue)
 5 = Special Order (16" min. - 21" max.)
 6 = 19-1/4" GRT/TNT
 7 = 19-3/4" Rocket (Black)

C.) Power Assist

1 = Manual
 2 = Mini Cyl (1-1/8" Piston)
 4 = Dual Power Cyl (1-3/8" Piston)
 5 = Dual Power Cyl (1-1/2" Piston)

D.) Rack End

1 = Tie Rod 5/8" Tapered Hole
 2 = On Center 5/8" Thread Stud
 3 = Rod End Eye 5/8" Thread Hole
 4 = On Center Rod End 5/8" Heim
 5 = Slotted Eye On Center 5/8" Heim

E.) Servo/Valve

185 = .185 XX-Light
 200 = .200 X-Light
 210 = .210 Light
 220 = .220 Light
 235 = .235 Med/Light
 250 = .250 Medium
 265 = .265 Medium
 275 = .275 Med/Heavy
 300 = .300 Bloomquist





Blaster 2

The following Blaster Coils share the same windings and high voltage output as the other Blaster 2 coils, but do not include a ballast resistor. When you are using an MSD Ign Control, the Ignition is responsible for delivering the voltage to the coil so a ballast resistor is not necessary.

MSD8202\$51.39

Blaster 3

It features an extra tall tower design to improve the coil wire attachment and spark isolation. Supplied with a 90° terminal and boot.

MSD8223\$52.63

High Vibration Blaster Coil

Metal canister is encased with epoxy to protect the windings from high vibration applications. Improved output coil for electronic ignitions, and MSD Ignitions (ballast resistor required for points). 100:1 turns ratio and lower primary resistance produce high voltage output. CARB E.O. Approved.

MSD8222...\$59.21

Blaster 2 Coil, w/Ballast Hardware

Improved output coil for stock points or electronic ignitions, Blaster Ignition or MSD 5, 6, and 7 Series. Supplied with two spark plug wire boots, terminals and a ballast resistor (required if used with stock points ignition). 100:1 turns ratio and lower primary resistance produce high voltage output. Chrome metal canister is filled with a premium grade oil for cooling. CARB E.O. Approved.

RedMSD8203\$58.10

MSD Blaster SS Coil

Improved output coil for electronic ignitions, and MSD Ignitions. Efficient winding design and assembly creates a compact housing. Primary and secondary windings are encased in Ciba polyurethane. 70:1 turns ratio and lower primary resistance produce high voltage output. Dupont Rynite housing with a tall tower and brass primary terminals. CARB E.O. Approved.

MSD8207...\$58.10

GM HEI Distributor Coil

Direct performance replacement for GM HEI coil-in-cap distributors. 70:1 turns ratio and lower primary resistance produce high voltage output. Full power sparks to 9,000 RPM when used with 8364 MSD HEI Module. Recommended for use with MSD HEI Module PN 8364. CARB E.O. Approved.

MSD8225...\$82.26

GM Dual Connector Coil

Direct performance replacement for GM dual connector coil. 100:1 turns ratio and lower primary resistance produce high voltage output. Works with stock ignition as well as MSD Ignitions. CARB E.O. Approved.

MSD8226...\$51.54

Ford TFI Coil, Hi Performance

Direct performance replacement for Ford TFI coil. 85:1 turns ratio and lower primary resistance produce high voltage output. Works with stock ignition as well as MSD Ignitions. CARB E.O. Approved.

MSD8227...\$51.54

GM Coil Pack, 2 Tower Style

Direct performance replacement for GM 2 Tower coils used from the mid 80's to late 90's. 80:1 turns ratio and lower primary resistance produce high voltage output. Works with stock ign as well as MSD Ign. CARB E.O. Approved.

MSD8224...\$51.54

Blaster Coils for Late Model Hemi Engines

Fire up your late model Hemi with a set of MSD's Blaster Coils. The Coils are a direct bolt-in and are spec'd with superior materials and winding ratios to improve the output of the coil while retaining the factory fit.

Blaster Hemi Coils.....Individual

Early Model, '03-05MSD8256\$59.21

Late Model, '06-08.....MSD8255\$62.50

Blaster Hemi Coils.....8-Packs

Early Model, '03-05MSD82568 ..\$429.95

Late Model, '06-08.....MSD82558 ..\$440.95

Ford Blaster Coil-On-Plug

The improved spark energy and voltage of MSDs Blaster 2 Coils, combined with reliability, have made them a favorite for performance enthusiasts. Whether firing a restored BOSS 429 or a Saturday night circle tracker, the Blaster 2 has always gotten the job done. MSD is excited to offer Blaster coils for late model Ford engines with Coil-on-Plug technology!

Ford Coil-On Plug

Individual

8-Pack

'99-04, 4.6L SOHC MSD8242...\$32.86

MSD82428...\$206.95

'05-On, 4.6L SOHC MSD8243...\$43.42

MSD82438...\$264.95

'99-04, 4.6L SOHC MSD8244...\$32.86

MSD82448...\$221.95

GM Single Connector Coil

Used on 1996-99 GM vehicles. Installation tip: If you plan to install an MSD Ignition with this coil, use a MSD8877 Harness for a direct plug-in installation.

MSD8231...\$51.54

Dodge Late Model Coil, 2 Pin

Direct performance replacement for late model Dodge vehicles. Works with stock ignition as well as MSD Ignitions. CARB E.O. Approved.

MSD8228...\$51.54

Ford DIS 4 Tower Coil Pack

Designed to be used with late model Ford waste spark ign systems. 83:1 turns ratio and lower primary resistance produce high voltage output. Secondary towers designed for snap on spark plug terminals. Primary terminals require Ford style connector. CARB E.O. Approved.

MSD8241...\$82.26

Mitsubishi Dodge Coil, 1996-on

Direct performance replacement for Mitsubishi 2.0L from early 1996 to early 1999. Direct performance replacement for Dodge 2.0L from mid 1997 to 2002. 77:1 turns ratio and lower primary resistance produce high voltage output. Works with stock ignition as well as MSD Ignitions. Flat terminal connection only. CARB E.O. Approved.

MSD8239...\$82.26

Blaster HVC, Works w/ MSD 6 Series Units

Designed for high rpm, long duration applications. Works with electronic ignitions and MSD Ign Controls (ballast resistor required for points systems). 100:1 turns ratio and lower primary resistance produce high voltage output. Windings are encased in blue epoxy and secured with extruded brackets. Spark plug style terminal and threaded brass primary studs. Supplied with rubber shock mounts. CARB E.O. Approved.

MSD8252...\$141.95

Pro Power HVC Coil, Use w/MSD 7 Series

Designed for racing applications with an MSD 7 Series Ign Control. Efficient E-core winding design produces more voltage and current. 85:1 turns ratio and lower primary resistance produce high voltage output. Windings are encased in red epoxy and secured with extruded brackets. Spark plug style terminal and threaded brass primary studs. Supplied with rubber shock mounts. No CARB Exemption Order Number.

MSD8251...\$141.95

MSD 6 HVC Coil

E-Core design produces more voltage and current while running 50% cooler than canister coils. Massive laminations and windings are engineered for less energy loss. Delivers high voltage to ionize the plug gap while the spark glows with high current.

MSD8250...\$141.95

HVC-2 Coil, 6 Series Ignitions

Designed for high rpm, long duration applications using MSD 6 Series Ign. New U-core winding design produces more voltage and current. 100:1 turns ratio and lower primary resistance produce high voltage output. Windings are encased in fracture resistant compound for vibration resistance. Dupont Rynite housing with isolated tower and brass primary terminals. Supplied with rubber shock mounts. No CARB Exemption Order Number.

MSD8253...\$228.95

HVC-2 Coil, 7 Series Ignitions

Designed for racing applications with an MSD 7 Series Ign Control. New U-core winding design produces more voltage and current. 70:1 turns ratio and lower primary resistance produce high voltage output. Windings are encased in fracture resistant compound for vibration resistance. Dupont Rynite housing with isolated tower and brass primary terminals. Supplied with rubber shock mounts. No CARB Exemption Order Number.

MSD8261...\$223.95

Pro Power Coil

High voltage coil designed for short duration applications only. Primary and secondary windings are encased in Ciba polyurethane for vibration protection. Extremely low primary resistance. Housing is molded from a durable and high dielectric polyester. Supplied with rubber shock mounts. For MSD 7ALs, 8 and 10 Ignitions only, not for use on street vehicles. No CARB Exemption Order Number.

MSD8201...\$135.95

Universal Coil Bracket

Perfect for canister type coils.

MSD8213...\$8.72

Firewall Feed Thru, Red

Absolutely the best way to route spark plug wire through the firewall.

MSD8211...\$18.60

Tach Splitter, Dual Ignition Systems

If you are running a dual ignition system, this little device will allow the tachometer to operate with both igns. Simply install the Splitter between the tach outputs and the Tach. Female fasten connectors match common racing connections.

MSD8911...\$17.51

Automatic Coil Selector

Perfect for running dual MSD Ignitions. Must run 2 Ignitions and 2 coils.

MSD8210...\$82.26

6 SERIES



Digital 6A Ignition Control

Higher output with 530 primary volts and 135mJ of spark energy Efficient components use less current to produce more power Same bolt pattern as the original 6AL with a lower profile housing Built-in LED for system checks All wires exit the same side through a locked, sealed connector Compatible for 4, 6 or 8-cylinder engines.
MSD6201...\$232.95



Digital 6AL Ignition Control

With Soft Touch Rev Control Higher output with 530 primary volts and 135mJ of spark energy Efficient components use less current to produce more power Set an rpm limit on the 6AL with two rotary dials Same bolt pattern as the original 6AL with a lower profile housing Built-in LED for system checks All wires exit the same side through a locked, sealed connector Compatible for 4, 6 or 8-cylinder engines.
Digital 6AL Ignition Control MSD6425.....\$269.95
Replacement Harness for 6425.. MSD8897.....\$18.95

2-Step Rev Control for the Digital 6AL

Since the new Digital 6AL Ignition uses rotary dials to adjust the rev limiter, our engineers were tasked with developing a 2-Step Rev Control that could be added to give racers the ability to switch to a low rpm limit to use on the starting line.

The new 2-Step is also digitally controlled and connects to the Digital 6ALs gray tach output wire. There are two easy to read rotary dials that let you set the launch rpm in 100 rpm increments. There is an activation wire that connects to the transbrake, a clutch switch or to the line-lock to activate the low rpm limit. When that switch is released, the low rpm limit is turned off and the car launches hard!
MSD8732...\$104.95



6-BTM Boost Timing Master

Multiple spark, capacitive discharge ignition control. Retard the ignition timing 1 degrees-3 degrees per pound of boost, maximum of 15 degrees, with dash-mounted adjustable control knob. Multiple sparks for 20° of crankshaft rotation. Works on 12 - 18 volt electrical system. Accepts breaker points, amplifier and magnetic pickup trigger inputs. 470 primary voltage output to coil. 110 millijoules per spark up to 15,000 RPM. Built-in Soft Touch Rev Control is adjustable with RPM Modules. Programmable for 4, 6, or 8-cylinders by cutting red/blue wire loops. Supplied with rubber shock mounts. Supplied with 3,000, 6,000, 7,000 & 8,000 RPM Module. CARB E.O. Approved.
MSD6462...\$484.95



6AL-2 Ignition Control

All new housing, digital circuits and performance. Built-in 2-Step rev control - with rotary dials. Higher output with up to 135mJ and 535 volts. Accepts Hall-effect, points and mag pickup triggers. Managed by an efficient digital control.
MSD6421...\$310.95



Digital 6-Plus Ignition Control

Switch between two rev limits that adjust with rotary switches in 100 rpm increments. Single stage retard for nitrous and top end performance. Start retard eases pressure on the starter, flywheel and engine. Adjustable magnetic pickup compensation produces accurate trigger signals. LED display warns of trigger signal problems or faulty charging system. Fully potted with polyurethane for vibration and water protection.
MSD6520...\$395.95



Digital Programmable 6AL-2

Advanced PC programming for use on street/strip and track cars PC Programmable with easy-to-use Windows based Pro-Data +Software Plot a timing curve based on boost pressure down to a 0.1° every 100 rpm Program three rev limits in 100 rpm increments Step retard for nitrous applications plus a boost timing map Capacitive Discharge technology for high voltage and spark energy.
MSD6530...\$413.95



6ALN Ignition Control

Multiple spark, capacitive discharge ignition control. Designed for circle track racing with NASCAR mandated connectors and clear epoxy potting compound for vibration protection. 6-pin Weathertight connector, mandatory for NASCAR use. Circuit board is encased in a clear two part silicone elastomer. Clear plastic base plate for easy tech inspection. Built-in Soft Touch Rev Control is adjustable with RPM Modules. Multiple sparks for 20 degrees of crankshaft rotation. Works on 12 - 18 volt electrical system. Accepts breaker points, amplifier and magnetic pickup trigger inputs. 470 primary voltage output to coil. 110 millijoules per spark up to 15,000 RPM. Programmable for 4, 6, or 8-cylinders by cutting red/blue wire loops. Supplied with rubber shock mounts. Supplied with 3,000, 6,000, 7,000 & 8,000 RPM Modules. No CARB Exemption Order Number.
6ALN Ignition ControlMSD6430\$360.95
Wire Harness for 6430MSDASY17296 ...\$35.32



MSD Box Mount

Box mount provides a quick release method for replacing MSD6420, 6425, 6430 and other ignition boxes with 7-1/2" x 3-1/2" center to center mounting dimensions. Kit includes aluminum box mount, four quick turn fasteners, springs and 1/8" aluminum rivets.
ALL81330...\$17.99



6CT Ignition Control

Superior design makes it the most advanced ignition to ever hit a circle track. Packed with legendary MSD Ignition power, the 6CT offers a slew of features. A large digital LED display makes it easier than ever to see the rev limiter setting when dialing it in using the laser etched rotary dials on the face of the unit. Rev limiting is controlled via microprocessor making it so smooth the chassis is virtually undisturbed when charging into turns. The rotary dials are also used to set cylinder select for 4, 6, and 8 cylinder engines, and to adjust the built-in start retard providing options of 0°, 10° or 20° of timing retard for quick starts. As an added bonus the LED display can be used as a live tach or will display your racecars battery voltage. The 6CT offers all this and more in a fully potted, tamper proof housing that utilizes a single connector to keep wiring tidy.
MSD6427...\$358.95

Wiring Harness

They are easy to install, but we also offer several plug-in Harnesses. These are especially handy for quick installation on late model vehicles! The Harnesses plug directly into your factory coil and harness then four color coded wires plug into the corresponding wires of the MSD. Two wires go from the MSD to the battery and you're done with no cutting or splicing!

MSD to Ford TFI HarnessMSD8874\$32.86
MSD to GM Dual Connector CoilMSD8876\$42.74
MSD to GM '96-On Single Connector Coil.....MSD8877\$42.74
MSD to '90-97 Dodge Ram 5.2/5.9LMSD8889\$20.80
MSD to '98-03 Dodge/ChryslerMSD8884\$38.35
MSD to GM HEI (int coil) w/o Vacuum Advance ..MSD8875\$60.31

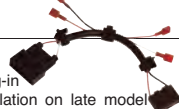

6M-2L Marine Certified Ignition w/Rev Limit

MSD's popular 6M-2 with a built-in rev-limiter. Multiple sparks improve starting, throttle response and idle quality. Circuitry is potted for a weather-proof housing. Weathertight connectors protect wiring from water and chemicals.
MSD6560...\$399.95



6 HVC, Professional Race w/Rev Control Deutsch Connectors

Multiple spark, capacitive discharge ignition control. Designed for professional racing apps that demand high rpm for long periods of time. Clear epoxy potting compound for vibration protection and clear base plate for easy tech inspection. 6-pin Weathertight connector, mandatory for NASCAR use. Special 4-pin connector to plug directly into the MSD Soft Touch Rev Control 8738 or Soft Touch Engine Control PN 8968. Multiple sparks for 20 degrees of crankshaft rotation. Accepts breaker points, amplifier and magnetic pickup trigger inputs. 550 primary voltage output to coil. 150 millijoules per spark up to 15,000 RPM. Works on 12 - 18 volt electrical system. Built-in reverse polarity protection circuit. Must be used with HVC Coil 8250. No programming loops. Supplied with rubber shock mts.

Fast Rev Limiter, Deutschs.....MSD6631\$554.95
Soft Touch Rev Limiter, Deutsch Connect..MSD6632\$539.95
Wire Harness for MSD6632.....MSDASY27196 ..\$34.01



MSD 6 HVC Coil

E-Core design produces more voltage and current while running 50% cooler than canister coils. Massive laminations and windings are engineered for less energy loss. Delivers high voltage to ionize the plug gap while the spark glows with high current.
MSD8250...\$141.95



Programmable Midget Ignition

It is a complete electronic distributorless system consisting of a powerful capacity discharge Ignition Control, a 4 tower high output coil pack and uses 2 non-magnetic pickups with a trigger wheel as a crank trigger source. This takes all of the mechanical variable out of the picture to produce exact ignition timing.

- Plot 2 timing curves ranging from 800-15,000 rpm in 0.1° increments.
- Select a rev limit from 2,000-15,000 rpm in 100 rpm increments.
- Battery monitor circuit shows real time battery voltage & a low voltage time %.
- Switch between 2 timing curves as track conditions change during a race.

MSD Programmable Midget Ignition...MSD6214\$785.95
Midget Coil Pack.....MSD8240\$142.95

8.5mm Wire Set for Midgets.....MSD31689\$64.69

Vibration Mounts

In many performance applications such as off-road, drag race, marine and oval track racing, strong vibration forces can be transmitted through the chassis to the MSD unit. To protect the MSD from excessive vibration, we recommend the use of these vibration mounts. MSD offers three types of vibration mounts, one for the MSD 5 and 6 Ignitions, one for the MSD 7, 8 and 10 Series, and one for the Pro Power Coil.



7AL-2, 7AL-3, 8 & 10 Series(1" x .75", 4/Card)...MSD8800 ...\$17.51
5 & 6, SCI, Digital 7-Series ...(.75" x .63", 4/Card)...MSD8823 ...\$16.42
Pro Power Coil.....(44" x .50", 3/Card)...MSD8825 ...\$15.31

7 SERIES

7AL-2 Ignition Control

Built-in two step rev control. Operates on 4, 6 or 8-cylinder engines. Troubleshooting LED for spark output diagnostics. Terminal strips for improved and easier wiring. MSD7222...\$588.95



The all new 7AL-3 is Better in Black Replacing the MSD7230

It has been a favorite of sportsman racers as well as racers that run multi-stage nitrous systems. The ignition combines high output spark energy for high compression race engines combined with the most popular drag racing accessories including a 3-Step rev limiter, 4-stage retards, a start retard and RPM Activated Switch. For 2013, MSD is relaunching the 7AL-3 with upgraded features, a new look and updated internal components including surface mount circuitry. The new ignition, PN 7330, is easy to spot with a black anodized housing and features a new adjustable start retard circuit. Also it now can be used on 4, 6 or 8-cylinder engines.



- Fits in the same mounting footprint of the original PN 7230
 - Compatible on 4, 6 and 8-cyl engines (the original version was for 8-cyl only)
 - Start retard is adj w/plug-in retard modules (the original retarded only 25°)
 - Retard stages require +12 volts to activate (the original required removing the activation wire from ground)
 - Surface mount assembly reduces internal components (original model had multiple board assemblies)
 - Black anodized housing stands apart from the original (the original was red)
- Racer input was garnered about the features of the new PN 7330 and MSD listened. The start retard is now adjustable, the four retard stages activated from +12 volts and the ignition can be used on 4, 6 or 8-cylinder engines.) MSD7330...\$744.95

8-Plus Ignition Control

Built-in 2-Step Rev Control. Compatible for 4, 6 and 8-cylinders. Works on single or dual coil output systems. MSD7805...\$1414.95



Programmable Digital-7 Plus

Map a complete timing curve for every gear. Stage retards can be set to ramp the timing. Updated X-Y plots with interpolation for smooth changes. View all ignition events in a new Launch History window including the retard sum, manifold pressure, rpm, shift points and more. Acquire 20 seconds of run data including two seconds prior to launch. Select the rpm limiter value in rpm/seconds. Program an rpm limit that is ramped during the launch. Vacuum advance and boost retard is selectable through a MAP sensor. There is a cam sync output for fuel controllers or data acquisition. Program your engine's firing order for ease of setting the cylinder-to-cylinder timing. Automatic magnetic pickup compensation for crank triggers or distributor pick-ups. Output to activate a device through rpm, time or pressure inputs. An upgraded micro-controller runs at 40MHz enabling timing accuracy within 0.1 degrees and +/-1 rpm at up to 10,000 rpm! MSD7531...\$929.95



Power Grid Ignition System

It is the next evolution of our Programmable 7-Series Ignition Controls. The Grid incorporates an efficient 32 bit microcontroller and a software program, called MSD View, and is USB compatible. The Windows based software is designed with tabs to help racers easily select different programming windows & parameters. Data acquisition files of the ignition are now captured on a micro SD card for ease of storage & reviewing.

- USB connection for ease of programming
- Timing based on engine rpm and gear value
- Five retard stages for nitrous
- Advanced individual cylinder timing based on gear or time
- Four steps of rpm limits for burnout, spool, launch and overrev
- Output switch set on rpm, pressure or time
- Shift light settings for each gear
- Ignition data acquisition accepts multiple runs



Controller.....MSD7730.....\$445.95
Ignition.....MSD7720.....\$495.95



DIS Plus Ignition Control

When Ford moved to the 4.6L Modular engine in the 96 Mustang, there were two coil packs with four towers each set up as a Waste Spark. They are designed for engines with coil pack, waste spark ignition systems. The DIS-2 has two channels, to fire two coil packs, while the DIS-4 is capable of firing up to four coil packs (or even 4 individual coils). Each Control delivers full power Capacitive Discharge sparks from idle through racing rpm. Below 3,000 rpm there is a series of multiple sparks that last for up to 20 of crankshaft rotation to improve idle, starting and throttle response. The adjustable features of the DIS Ignitions have also been upgraded with rotary dials. These provide easier, and more precise adjustments of the over-rev limiter and the holeshoot rev limit. Now a step retard that can be wired directly to a nitrous system or switch for activation! For use on 6 or 8-cyl engines with two, three or four coil packs.

- Two Step Rev Control
- Step Retard
- LED Monitor

MSD DIS-4 Plus (For use on 6 or 8 cyl with two, three, or four coil packs) MSD62152...\$673.95



MSD DIS-4 Plus High Output

The DIS Ignitions all deliver a stout, CD spark that is capable of burning the majority of air/fuel mixtures. There are of course exceptions, such as full bred race engines running high boost pressures from turbos, blowers or nitrous. To answer these needs, we offer a Higher Output version of the DIS Ignition Controls. The DIS Plus HO Ignitions produce an incredible 170 millijoules of spark energy with 470 primary volts. This increased output will light up fuel mixtures even under extreme cylinder pressures. The DIS-HO boxes are not CARB approved and are designed for drag racing apps only.

- Two adjustable
- Rev Limits Diagnostic LED
- Adjustable retard stage
- Ignition Interrupt Circuit

MSD-4 Plus HO, 2, 3 or 4-Coil Packs...MSD62153...\$751.95



Blaster Single Tower Coil

For performance applications with multi channel coil drivers this Single Tower Blaster Coil is a great choice. The Coil will also take off your MSD DIS-HO Ignition system when its set up for a coil per cylinder ignition system. The coil's low resistance and quick rise time make it ideal for high revving, multi-coil performance systems. Blaster Single Tower Coil.....MSD8232.....\$61.40



Coil Interface Module

This module goes between the factory GM ignition module and coils. It has color coded wires that connect to the DIS wiring and are molded using Dupont Rynite for its high dielectric strength and connect directly to the factory terminals. GM Coil Interface Module.....MSD8870.....\$49.33



RPM Module Kits

RPM Module Kits include five modules in 200 rpm increments. Each kit is within a 1,000 rpm range. For example, the MSD8745 is supplied with: 5,000, 5,200, 5,400, 5,600, 5,800 modules.

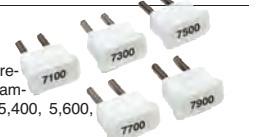

Even Increments	MSD Part Number	Price	Odd Increments	MSD Part Number	Price
3,000-3,800	MSD8743	\$35.06	3,100-3,900	MSD87431	\$35.06
4,000-4,800	MSD8744	\$35.06	4,100-4,900	MSD87441	\$35.06
5,000-5,800	MSD8745	\$35.06	5,100-5,900	MSD87451	\$35.06
6,000-6,800	MSD8746	\$35.06	6,100-6,900	MSD87461	\$35.06
7,000-7,800	MSD8747	\$35.06	7,100-7,900	MSD87471	\$35.06
8,000-8,800	MSD8748	\$35.06	8,100-8,900	MSD87481	\$35.06
9,000-9,800	MSD8749	\$35.06			
10,000-10,800	MSD8750	\$35.06			
11,000-11,800	MSD8751	\$35.06			

Dirt MSD 6ALN

7600 RPM Spec Box is now mandate by DIRT 358 Modifieds. MSD64316...\$383.95



MSDASY25452

Wiring Harness

For Spec Box MSD64316 MSDASY25452...\$35.95



Circle Track RPM Control Digital Soft-Touch HEI Rev Limiter

Fully digital operation allows for accurate rev limiting. Rotary dials eliminate the need for plug-in RPM modules. Easy installation to any HEI distributor with plug-in wiring and connectors. Epoxy filled for endure extreme racing conditions & eliminate potential tampering with circuitry.



MSD8727CT...\$175.95

MSDASY26434

Wiring Harness

Works on MSD8727CT.....MSDASY26434...\$19.01



MSD Super HEI Kit

It is one of MSD's solutions to the GM HEI's common problem of power loss and lack of response or bypass the low-powered HEI module and coil and replace them with the MSD Digital 6AL Ign Control and the Blaster 2 high input coil. The result is more power, increased rpm range, easier starting, plus better mileage and performance. The Kit includes the new MSD Digital 6AL Ignition, Blaster SS Coil, coil wire, and HEI dust cover. The 6AL has a Soft Touch Rev Control to protect your engine from overrev damage.

MSD85001...\$347.95



GM HEI Billet Distributor

A complete performance HEI dist upgrade for Chevy V8 engines. Easy-to-adjust mech advance with supplied springs and stop bushings. Vacuum advance canister for improved economy (can be locked out). CNC machined billet aluminum housing and billet alum base. Polished steel shaft is QPQ coated and guided by a sealed ball bearing. Advance plate and weights are fine blanked from chrome moly steel and QPQ coated for friction reduction. Mech advance assembly can easily be locked out. Advance weight pins are staked and tig welded to the plate. Nylon pads ensure smooth operation of the advance weights. Special oil tract improves lubrication to the distributor and cam gear. Supplied with a 7.5 amp, single spark, inductive discharge ignition module, MSD8364, and MSD HEI Coil, MSD8225 Full spark energy output to 9,000 RPM. Supplied with brass terminal dist cap and rotor CARB E.O. Approved.

MSD Pro-Billet ChevyMSD8365\$432.95
MSD HEI Coil.....MSD8225\$82.26

Cap: MSD84111
Rotor: MSD84101



HEAT HEI Module

Easily installs to non-computer controlled (4-Pin) HEI housings. Built-in adjustable rev limiter can easily be set externally. Advanced dwell control for improved high rpm output. The Hottest HEI Module you buy-period! Produces an incredible 7.5 amps of juice! Adjust the rev limiter without removing the cap! Fits in stock HEI distributors.

MSD83647...\$116.95



Ultimate HEI Kit

Rebuild your GM HEI with MSD performance. Exceptional high speed coil saturation for full power high rpm operation. Matched Coil and Module produce the highest voltage and energy. Complete kit with a brass terminal Cap, Rotor, Module, Coil and dust cover.

MSD8501...\$251.95

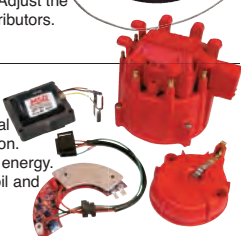

Chevy V8 Pro-Billet Distributor

CNC machined billet alum housing and billet alum base Easy-to-adjust mechanical advance with supplied springs and stop bushings Maintenance-free magnetic pickup and precision reluctor create stable trigger signals throughout the rpm range Polished steel shaft is QPQ coated and guided by a sealed ball bearing and extra long sintered bushing Advance plate & weights are fine blanked from chrome moly steel and QPQ coated for friction reduction Mechanical advance assembly can be locked out for crank trigger systems. Nylon pads ensure smooth operation of the advance weights Special oil tract improves lubrication to the distributor and cam gear O-ring seals can be added to modified blocks to improve oil pressure control Supplied with an HEI style distributor cap and rotor (accepts Cap-A-Dapts) Must be used with an MSD Ignition Control Will not accept a vacuum advance canister. No CARB Exemption Order Number.

Chevy V8 Pro Billet Dist.....MSD8551 ..\$271.95
Chevy Slip Collar ChevyMSD85561 ..\$319.95
Extra Tall Slip Collar Chevy...MSD8547\$363.95

Cap: MSD8433
Rotor: MSD8467



Street Pro-Billet V8 Distributor

It is a popular route for people looking for a proven race performance for their street cars. A vacuum advance canister provides economy and the proven MSD mechanical advance gives you the opportunity to dial-in a timing curve to fit your needs. Inside, an oversized steel shaft is QPQ-coated for low friction and rides in a sealed ball bearing at the top of the distributor with an extra-long sintered bushing at the bottom. This combination keeps the shaft steady creating accurate spark delivery at any rpm. The Street Pro-Billet relies on a magnetic pickup to trigger the MSD Ignition Control which delivers the powerful sparks to the coil. This pickup is extremely accurate and never needs adjusting.

MSD8361...\$287.95

Cap: MSD8433
Rotor: MSD8467



Chevy V8 w/Internal Module Distributor

Simple and clean installation with only three wires to connect. Powerful built-in module produces a 7.5 amp single spark through high rpm. Easy-to-adjust mech advance with supplied springs and stop bushings Vacuum advance canister for improved economy (can be locked out). CNC machined billet alum housing and billet alum base. Maintenance-free magnetic pickup and precision reluctor create stable trigger signals throughout the rpm range. Polished steel shaft is QPQ coated and guided by a sealed ball bearing. Advance plate and weights are fine blanked from chrome moly steel and QPQ coated for friction reduction. Mech advance assembly can be locked out for crank trigger systems. Advance weight pins are staked and tig welded to the plate. Nylon pads ensure smooth operation of the advance weights. Special oil tract improves lubrication to the dist and cam gear. O-ring seals can be added to modified blocks to improve oil pressure control. Supplied with an HEI style dist cap and rotor (accepts Cap-A-Dapts) Does not require an MSD Ignition Control CARB E.O. Approved.

MSD8360...\$348.95

Cap: MSD8433
Rotor: MSD8467



Chevy V8 Pro-Billet Dist

CNC machined billet alum housing and billet alum base. Adjustable slip collar mounting flange for engines with modified deck heights. Polished steel shaft is QPQ coated and guided by a sealed ball bearing. Supplied with a 0.006" oversized bronze gear installed. Supplied with an HEI style dist cap and rotor (accepts Cap-A-Dapts). Must be used with an MSD 6, 7, 8, or 10 Series Ign. Will not accept a vacuum advance canister. No CARB Exemption Order #.

Red MSD85501...\$316.95
Black... MSD85505...\$327.95

Cap: MSD8433
Rotor: MSD8467



Circle Track HEI

MSD engineers have worked tirelessly to perfect the new circle track HEI. "Stock appearing" to meet sanctioning body HEI distributor rules. Bulletproof "stock appearing" ignition module provides ultimate reliability. High output ignition coil for peak spark energy at any RPM. High quality, QPQ coated distributor gear. QPQ coated chromoly advance cam and weights provide smooth operation and precision timing. Works perfectly with MSD 8727CT HEI Circle Track RPM Control.

MSD8362CT...\$307.95

Chevy V8 Pro-Billet Distributor w/Locked-Out Timing & Bronze Gear

Whether cruising the streets or racing stock cars, dragsters, boats or trucks, MSD has a distributor for it. MSD uses state-of-the-art, Computer Numerical Controlled (CNC) mills and lathes to machine each housing. After a long series of precise cuts and movements, the billet is formed into a flawless distributor housing that is accurate to within 0.001". The flex-free housings are lightweight, have no porosity or weak areas and look great on polished, show quality engines.

MSD85505...\$327.95

Cap: MSD84333
Rotor: MSD8467

Pro-Billet Chevy HEI Distributor

The Chevrolet HEI Distributor is a favorite for muscle cars, street rods and even circle track racers. The integrated coil keeps underhood wiring clean, and for race cars, the idea of running one wire to the distributor keeps things simple. However, when it comes to performance, the stock HEI falls short. MSD answers the need for a strong, accurate and high performance HEI with our Pro-Billet HEI.

MSD83653...\$444.95

Cap: MSD84333
Rotor: MSD8467

Digital E-Curve Distributor

Digitally controlled stand-alone distributor with adjustable electronic advance. Set a centrifugal advance and vacuum advance curve electronically. High output ignition module produces a powerful spark for improved performance. Simple three wire connection and you're ready-to-run Dial-in a rev limit to protect your engine from over rev damage.

MSD8394...\$473.95

Cap: MSD8433
Rotor: MSD8467

Pro Billet EFI Late Model GM

GM Late Model Performance enthusiasts will be happy to see this Pro Billet Distributor. The MSD8366 is a drop-in replacement for GM V8s using the small cap distributor with a dual connector coil found in cars from 1987-93 and trucks from 1987-95. This 0.500" shaft also receives a QPC coating for increased friction reduction and corrosion resistance.

MSD8366\$331.95

V6 Cap:MSD8430
V8 Cap:MSD8406
Rotor: MSD8531

Pro-Billet LT1

Advanced optical encoder trigger design for accuracy & reliability. Easily adjust the timing up to +/-5. Improved housing design & extra bolt eliminates leaks. Fresh air vented & sealed to keep the elements out. Large ball bearing stabilize.

Pro-Billet LT1 Distributors:

'94-'96 Late Model MSD83811...\$545.95

'94-'96 Early Model, supplied with fresh air hoses

MSD8381*...\$545.95



Chevy Flat Top Pro-Billet Distributor

Crab cap will clear cowlings, exotic intakes and air cleaners Mechanical advance is easy to adjust for your engine Maintenance-free magnetic pickup provides accurate trigger signals.

MSD84891...\$417.95

Cap: MSD8541
Rotor: MSD84673



Chevy Pro-Billet Small Dia V8 Dist.

CNC machined billet alum housing is 3/8" smaller in diameter and 7/8 shorter than conventional Chevy V-8 distributors with the point type cap. Adjustable slip collar mounting flange for engines with modified deck heights. Must be used with an MSD 6, 7, 8, or 10 Series Ignition. Supplied with small diameter HEI style distributor cap and rotor (will accept 8441 Cap-A-Dapt). Will not accept a vacuum advance canister. No CARB Exemption Order #.

MSD8570...\$313.95

Cap: MSD8431
Rotor: MSD8467



MSD Ready to Run Distributor

MSD offers a line of distis called Ready-to-Run. The biggest visual difference is that the distributor has a 3-pin Weathertight connector. These distributors have a built-in ignition module, so an MSD Ign control is not required. They are simple to drop in and connect with 2 wires (power, coil negative, and ground) making them favorites for street rods and muscle cars. They also have a gray tach output wire to trigger a tach or even aftermarket EFI system. Plus, there is now an adjustable rev limiter! The inductive ign module is built into the housing of the dist and packs a powerful spark. You'll notice an immediate difference if you replace an old points distributor or low output replacement. Not only do you get the ease of installation and a good spark, but there's also a vacuum advance for economy and an easy-to-adjust mech advance. These are available for Chevy V8s and small block Fords and Chryslers. The big advantage is these distributors offer an electronic advance that is adjustable with rotary dials under the cap! No springs or bushings to adjust with the E-Curves.

Chevy

348/409.....MSD8393*...\$440.95

Ford

Ford 289/302	Iron Gear	Steel Gear
351C-460.....MSD8352**\$429.95	MSD83521** ..\$471.95
351W.....MSD8354**\$429.95	MSD83541** ..\$471.95
289, 302.....MSD8350**\$440.95	MSD83501** ..\$522.95

Pro-Billet Ready-to-Run for:

FE, 332, 352, 360, 390, 406, 410, 427, 428 MSD8595** ..\$440.95
Y-Block, 239, 272, 292, 312 MSD8383** ..\$482.95
(may hit firewall seam on '57-59 full size cars)

Flathead Ford Ready to Run Dist for '49-53 MSD8573* ..\$517.95

Chrysler

273, 318, 340, 360.....MSD8388*...\$440.95
383, 400.....MSD8386** ..\$467.95
426, 440.....MSD8387** ..\$440.95

AMC V8.....MSD8523* ...\$440.95
Oldsmobile V8.....MSD8529* ...\$440.95
Pontiac V8.....MSD8528* ...\$440.95
Buick 400, 430, 455.....MSD8552* ...\$440.95
Buick Nailhead, 322, 364, 401, 425.....MSD8524* ...\$432.95

Crate Engine Kits

Everything you need to fire up your new crate engine! Pro-Billet HEI or Ready-to-Run Distributor 8.5mm Super Conductor Plug Wires and Pro-Clamp separators Billet Hold-Down Clamp is also supplied.

GM Crate Ignition Kit

(MSD8360, MSD8207, Universal Wire Set)
MSD84741 ..\$502.95

Ford Crate Ignition Kits:

289, 302.....MSD84745 ..\$622.95
351W.....MSD84746 ..\$712.95
351C, 460.....MSD84747 ..\$609.95

OEM Upgrade

MSD also offers several distributors that are Pro-Billet designs, yet they're suitable as performance replacements for OEM models. Examples include the popular Ford TFI used in Fox bodied Mustangs. These distributors feature increased strength and support, yet incorporate the factory style module, pickup and connectors for a drop-in replacement.

Chevy

Chevy In-line 6 Cylinder.....MSD8515†.....\$363.95

Ford

2.3L Distributor.....MSD8473√.....\$373.95

Ford Billet Distributors

351C, 351M, 400, 429, 460.....MSD8580††...\$297.95
289C, 302.....MSD8582††...\$297.95
351W.....MSD8584††...\$292.95

Special Ford Applications

289, 302 with Steel Gear

for Hydraulic Roller Cams.....MSD8598††...\$308.95

351W for use w/Edelbrock

Victor Jr. Intake Manifold.....MSD85805††...\$297.95

351W w/steel gear (hydraulic roller cams) MSD85840††...\$337.95

Chrysler 318, 360.....MSD8534* ..\$260.95

Chrysler 318, 340, 360, E-Curve.....MSD8504* ..\$473.95

Oldsmobile V8 Dist 350-455.....473.95* ..\$473.95

Cadillac V8 Dist w/Vacuum Advance.....MSD8363* ..\$373.95

VW Billet Distributor.....MSD8485√.....\$308.95

Pro Billet Distributors

This pretty well covers all of our distributors, however this is our traditional distributor and they require an MSD Ignition Control such as a GAL or 7AL-2 Ignition Control. The distributor has a 2-pin connector that plugs directly into an MSD Ignition. These distributor are available from AMC to the famous W-Chevy motor. They're built for everything, from powerful street cars to racers. Some have vacuum advance while others may be locked out. The important thing to note is that an MSD Ignition Control is required and are identified by the 2-pin connector.

★ Cap: MSD8433
Rotor: MSD8467

△ Cap: MSD8431
Rotor: MSD84211

f Cap: MSD8408
Rotor: MSD8070

★★ Cap: MSD8431
Rotor: MSD8467

†† Cap: MSD8408
Rotor: MSD8423

‡ Cap: MSD8541
Rotor: MSD84673



Ω Cap: MSD84314
Rotor: MSD84674

Corvette w/Mech Tach Drive 63-74 Apps .MSD8572* ..\$450.95

Ford: FEMSD8594* ..\$330.95
289, 302 E-CurveMSD8503* ..\$473.95

Ford 289, 302 Steel Gear

Pro-Billet Cam Sync Distributors for Ford:

289, 302, Steel GearMSD2358Δ..\$485.95
289, 302, Bronze GearMSD2360Δ..\$551.95
351W, Iron GearMSD2362Δ..\$538.95

5.0L EFI Late Model Ford Distributors:

1986-93.....MSD8456f...\$341.95
1994-95.....MSD8455f...\$330.95

5.8L EFI Pro-Billet Distributors:

w/Module, non-roller camMSD8453f...\$352.95
w/Module, steel gear (factory roller-cam) .MSD8452f...\$330.95

For remote Modules,

steel gear (factory roller-cam).....MSD8451f...\$356.95

Ford Small Diameter Distributors:

351C-460MSD8577** ..\$319.95
351WMSD8578** ..\$319.95
289, 302.....MSD8579** ..\$311.95

With Vacuum Advance:

351C-460MSD8477** ..\$390.95
351WMSD8478** ..\$407.95
289, 302.....MSD8479** ..\$337.95

Ford Dual Pickup Distributors:

V8, 289, 302MSD8382††\$372.95
V8, 351WMSD8384††\$363.95

Early Hemi: 331, 354.....MSD8391* ..\$440.95

392.....MSD8389* ..\$440.95

Chrysler: 383, 400.....MSD8545** ..\$330.95
440, 426.....MSD8546** ..\$329.95

AMC: 290, 304, 343, 360, 390, 401.....MSD8519* ..\$325.95
Jeep 1-6, 232, 258.....MSD8516* ..\$373.95

Buick: 400, 430, 455.....MSD8517* ..\$341.95
215, 300, 340, 350.....MSD8548* ..\$363.95

Pontiac V8 350-455:.....MSD8563* ..\$337.95

External Ign Module & Coil must be purchased separately



Pro Mag 12LT Short Base for Sprint Cars

The new but shorter Pro Mag 12 LT Generator. The major modifications include a 3/4 of an inch shorter height to clear low hanging Sprint Car air cleaners and a newly engineered raised oil passage groove that will prevent oil leakage and provide superior oiling in large cam tunnel engine blocks. Most importantly these generators are built by the professionals in the MSD Focus Factory for unmatched quality assurance.

Features: Raised oil passage groove. Designed to clear low hanging Sprint Car air cleaners. 3/4 inch shorter than MSD's standard height 7908 generator. Designed for engine blocks with 50mm, 55mm, and 60mm diameter cam tunnels. Newly engineered raised oil passage groove to prevent oil leakage and provide superior oiling in large cam tunnel engine blocks. For use in raised cam, large cam journal blocks with dry sump oiling systems ONLY. MSD79081.....\$1825.95



Street Fire Ignition

Capacitive Discharge Tech. Multiple sparks improve starting and idle. Full power output at high rpm. Easily connects to points, amplifiers and magnetic pickup distributors. Adjustable rev limiter for overrev protection. This Street Fire CDI Ignition is perfect for budget minded enthusiasts. The ignition offers capacitive discharge technology and will fire a series of multiple sparks that lasts for 20° of crankshaft rotation when the engine is running under 3,000 rpm. This ensures combustion and produces great throttle response and smooth idle. The CDI is built around a durable cast aluminum housing and easily connects to points, amplifiers and magnetic pickup distributors. There is even an adjustable rev limiter for overrev protection!

MSD5520...\$165.95



Street Fire Coils

We're excited to introduce several new coils to the Street Fire line. These coils mount directly in place of factory style versions and accept the OEM connectors as well. Performance output is improved thanks to a careful selection of better materials and efficient winding ratios.

Ford TFI Coil.....MSD5527\$43.85
 GO Dual Connector Coil.....MSD5526\$43.85
 Canister Coil.....MSD5524\$40.54
 Internal HEI Coil.....MSD5525\$50.42

Ford 6-Tower Coil Pack,
 1994-2000MSD5528\$92.13
 2001-2004MSD5529\$100.95



Street Fire Chevrolet V8 GO HEI Distributor

All new components, including the coil, spec'd by MSD engineers. The only value priced HEI with a full 1 yr warranty Heavy duty distributor gear for durability Welded weight pins and heavy duty construction Adjustable vacuum advance helps tune it to each engine 21° of mech advance. We know the importance of a centrifugal advance in a distributor so our engineers made sure that the Street Fire receive an advance assembly with coated weights and welded weight pins (not just pressed in like other models). Another area that you cannot afford to scrim on is with a distributor gear. It is fit with the same gear that is used on our Pro-Billet models. The metallurgy of this gear has been refined for years to perform through the harshest conditions.

MSD8362...\$161.95

GO HEI Weight and Spring Kit

This kit will help you achieve the solid ignition timing you need! The Kit comes with new advance weights, springs to set the rate of advance and new bushings. This is designed for the Street Fire HEI and stock style HEI Distributors. (Not for use with MS)

MSD8428...\$24.10



Cap and Rotor Kits

This kit will help you achieve the solid ignition timing you need! The Kit comes with new advance weights, springs to set the rate of advance and new bushings. This is designed for the Street Fire HEI and stock style HEI Distributors. (Not for use with MS)

GO Points Style with V8 Socket Cap.....MSD5500\$27.38
 GO HEI, V8 Internal Coil.....MSD5501\$27.38
 GO External Coil, V8 EFI.....MSD5502\$27.38
 GO External Coil, V6 EFI.....MSD5503\$27.38
 Ford V8 Socket Cap.....MSD5506\$27.38
 Ford Duraspark V8.....MSD5504\$27.38
 Ford/MSD TFI V8.....MSD5505\$27.38

Single Coils

Look no further when it's time to tune-up your LS! Bolt on legendary ignition performance with MSD's direct replacement coils. Reliable parts from the ignition leader at a price that won't break the bank. Excellent reliability. Direct bolt-in replacement. Exceptional Value.

GM LS1/LS6 Single Coil, '98-06 Black

SingleMSD82623\$66.89
 8 PackMSD826283\$479.95

GM L-Series Truck Single Coil, '99-07 Black

SingleMSD82633\$54.82
 8 PackMSD826383\$403.95

GM L-Series Truck Single Coil, '99-09 Black

SingleMSD82643\$54.82
 8 PackMSD826483\$403.95

GM L-Series Truck Single Coil, '05-09 Black

SingleMSD82653\$69.08
 8 PackMSD826583\$440.95



Street Fire GO EFI Distributors

They are ready to drop in to your V8 engine to replace the worn OEM piece. A factory style ignition module is included along with a durable new cap and rotor. The cast housing features a long sintered bushing to add stability and timing accuracy to the ignition.

Street Fire GO EFI Distributors

GO used this distributor when trucks first moved to EFI back in 1988! It was carried over into cars and was used through the mid 1990s and the introduction of the Vortech engine and LS Series blocks. Also, many aftermarket EFI system require this style distributor and module.

MSD5591...\$202.95

Street Fire GO Vortech Dists

GO moved to this distributor in the late 1990s and only used them for a few years. The unique flat cap design acts as a "correct-a-cap" meaning that the even number spark plug wires are all on the passenger side while the odd numbers are all on the driver's side.

Distributor.....MSD5592\$252.95

Cap and Rotor Kit.....MSD8017\$59.21

Street Fire Ford TFI

One of the most popular Ford distributors in use is the TFI version used in the 5.0L Mustangs from '86-94. Since these cars are getting up there in miles and years, Street Fire offers a great OEM upgrade and an even better price. As with all of the Street Fire Distributors, each one is spec'd by MSD engineers. The Ford TFI is supplied with the correct TFI ignition module and accepts the factory style connector.

Of course a new cap and rotor are supplied to top the system off, as well as a fresh gear for durability.

MSD5594...\$213.95

Street Fire Wires

They feature a low resistance conductor that's wrapped in a sleek and durable black sleeve. The terminals are covered in black boots that protect the conductor from engine heat to ensure spark delivery.

- Helically wound conductor suppresses electro & radio noise.
- Kevlar core combination for great strength and durability.
- Heavy duty terminals for secure connection.
- 8mm silicone and synthetic jacket resists heat and abrasion.
- 500 Ohms per foot resistance for improved spark delivery & power.
- Silicone boots protect against high exhaust temps.



Chevy

Small Block Chevy, 350 HEI.....	MSD5554.....	\$41.64
Chevy 454, '74-76 HEI.....	MSD5560.....	\$44.95
Chevy 366-454, Socket.....	MSD5561.....	\$44.95
Chevy Truck 305-350, '85-On.....	MSD5562.....	\$41.64
Corvette, 350 TPI, '84-91.....	MSD5563.....	\$43.85
SBC, Socket Cap, under Manifold.....	MSD5564.....	\$44.95
SBC, Socket Dist, Cap over VC.....	MSD5565.....	\$44.95
Corvette 305-350 HEI, '75-82.....	MSD5566.....	\$43.85
Chevy 454, '75-On HEI.....	MSD5567.....	\$44.95
Chevy 454, '88-On.....	MSD5569.....	\$44.95
'88-On Chevy Capric/Camaro.....	MSD5570.....	\$44.95
GO F-Body, Corvette, LS-Series, '97-On.....	MSD5572.....	\$50.42
GO Truck, Tahoe, Suburban, Vortech V8, '96-97.....	MSD5573.....	\$49.33
GO Truck, LS, LQ-Series, '99-05.....	MSD5574.....	\$40.54
GO F-Body, LT1, '93-96.....	MSD5575.....	\$50.42
Chevy Caprice, Impala, LT1, '94-96.....	MSD5576.....	\$72.38
GO, Vortech V6, 4.3L, '96-97.....	MSD5577.....	\$41.64

Dodge/Chrysler

'73-On, 318-360, Socket.....	MSD5530.....	\$42.74
'73-On, 383-440, Socket.....	MSD5531.....	\$42.74
'94-97, Dodge Ram 318-360.....	MSD5532.....	\$42.74

Ford

Ford 351W, 400, 460, '77-On HEI.....	MSD5540.....	\$42.74
Ford 302, 351W, HEI.....	MSD5541.....	\$42.74
Ford 351C-460, Socket.....	MSD5542.....	\$42.74
Ford 289-302, Socket.....	MSD5543.....	\$42.74
Ford Mustang 5.0L, 94-On.....	MSD5544.....	\$42.74

Pontiac

Pontiac Grand Prix GTP V6, '97-On.....	MSD5539.....	\$52.63
--	--------------	---------

Universal

These kits are supplied only with the spark plug boot installed. This way you can route the wires exactly as you'd like for a custom fit. Terminals and boots are supplied for the dist side that you install with a special tool that is also supplied. All kits are for 8-cylinder.

Multi-Angle Plug, HEI Cap.....	MSD5550.....	\$46.04
Multi-Angle Plug, Socket/HEI.....	MSD5551.....	\$49.33
90°, Plug/90° Plug.....	MSD5552.....	\$46.04
90°, Socket/HEI Cap.....	MSD5553.....	\$49.33

HEI Vacuum Advance Stop Plate

This little plate allows you to limit the amount of vacuum advance on your Pro-Billet HEI, MSD8365, and Street Fire HEI, MSD8362.

MSD84281...\$10.91

Magnetic Pickup for all MSD Billet Distributors

It is the same high output assembly that is currently found in all MSD Dists. It is supplied with the two pin connector installed. Note: Not for use a replacement on OEM Dists.

MSD84661...\$30.67



Chevy V8 Dual Pickup Distributor

Dual magnetic pickups are placed 180° apart to provide a complete redundant ignition system for racing applications. Easy-to-adjust mech advance with supplied springs and stop bushings. Advance plate and weights are fine blanked from chrome moly steel and QPQ coated for friction reduction. Advance weight pins are staked and tig welded to the plate. Nylon pads ensure smooth operation of the advance weights. CNC machined billet alum housing and billet alum base. 0.500 steel shaft is QPQ coated and guided by a sealed ball bearing and an extra long sintered bushing. Special oil tract improves lubrication to the dist and cam gear. O-ring seals can be installed for oil pressure control (modified blocks only). Adjustable slip collar mounting flange for engines with modified deck heights. Will not accept a vacuum advance canister. Mech advance assembly can be locked out for crank trigger systems. Supplied with an HEI style dist cap and rotor and accepts a Cap-A-Dapt. Must be used with an MSD 6, 7, 8, or 10 Series Ign No CARB Exemption Order Number.



Cap: MSD8433
Rotor: MSD8467

MSD8356...\$347.95

Iron Gears

Increased outer hardened layer thickness (RC 55-60). Micro polished surface for smooth contact. Proprietary formula for ductile iron. Melonite QPC coating reduces friction and initial wear. Interstitial carbide concentration improves wear resistance and running properties.



Chevy, .500" ID.....MSD8531.....\$33.97
Chevy, Melonized, Marine Applications, 500" ID.....\$71.28
Ford 351W, .531" ID.....MSD8582.....\$24.10
Distributor Gear, AMC.....MSD8005.....\$64.69

Ford Gears: Some Ford engines were equipped with dist gears made of different gears made of different materials, due to the camshaft used. When the most common engine, the 302, was equipped with EFI in the mid '80s it also used a hydraulic roller camshaft, which required a steel gear. MSD offers several replacements.

Iron Gear, Ford 289/302: replacement for carbureted Ford distributors with 0.486" ID and MSD8582, MSD8579, MSD8479, MSD8352, and MSD8503
MSD8583.....\$83.35

Steel Gear, Factory EFI 5.0L: replacement for MSD8455 and MSD8456 also for MSD 351W dists with 0.531" ID
MSD85834.....\$83.35

Steel Gear, 351C-460 w/Hydraulic Roller Cam: MSD85813.....\$92.13

Bronze Gears

MSD Distributor gears are machined from quality AMPCO 45 aluminum bronze containing 5% nickel. This special combination creates high strength gear teeth that are less prone to wear even with high-volume oil pumps.



Chevy, .500" ID.....MSD8471.....\$60.31
Chevy, .500" ID (Over sized) +0.006".....MSD8472.....\$77.86
Pontiac V8, 500" ID.....MSD85631.....\$73.48
Ford 351C, 351M, 400, 429, 460, FE, .530" ID.....MSD8581.....\$53.72
Ford 351W, .530" ID.....MSD8585.....\$53.72

Bronze Distributor Gears



When installing a steel billet roller camshaft, a bronze dist gear must be installed in place of the original cast iron gear. They offer high strength to withstand the stresses created by high pressure oil pumps. Roll pins are included.



0.491" Bronze Distributor Gear...ALL81310...\$31.99

Carbon Ultra-Poly Composite Dist Gear

Manufactured from Carbon Ultra-Poly these gears represent the future of dist gears. These super tough gears show great promise in solving the wear issues associated with bronze gears in racing applications.



Chevy

Part #DescriptionFits Shaft Dia
COM12140V8 Sm and Big Block500"\$116.44
COM12146For .006" Oversized500"\$116.44



Bushing & Spring Set, MSD Dist.

The MSD Distributor Advance Kits are the same kits that come with your MSD Distributor. The kit contains an assortment of springs and advance limit bushings.



MSD8464...\$16.42

Dist Hold Down Clamp, Billet, Chevy

They are strong enough to keep the timing locked in place whether you are using an MSD Billet Distributor or Pro Mag. The MSD Hold Down Clamp is CNC machined from steel and fits all MSD Pro-Billet Chevrolet distributors and the Pro Mags. Each clamp includes the mounting stud, lock washer and nut.



MSD8110...\$36.16

EFI Sync Distributor

If your EFI has limited space in the back of the engine due to the intake combination or firewall, this low-profile dist is for you! The sync pickup of this dist is fixed at 45° BTDC on the number one cylinder. This signal will reliably alert your ECU as when the number one cylinder is preparing to fire. The dist uses a wide, Ford-style cap to improve voltage dist and to reduce the chances of ionization and spark scatter. A .0500" polished steel shaft is responsible for spinning the rotor and is guided by a sealed ball bearing guide and bushing.



Cap: MSD8408
Rotor: MSD8457

MSD2340...\$626.95

Chevy Crab Cap Crank Trigger Distributor

Designed to fit low in the block to clear firewall and intake combinations. CNC machined billet alum housing and Dupont Rynite base is designed for standard Chevy blocks. Adjustable slip collar for engines with modified deck heights. 0.500" taller for extra tall Chevy based engine blocks. Oversized polished steel shaft with a QPQ coating for friction reduction. Shaft is guided by a sealed ball bearing and an extra long sintered bushing. Special oil tract improves lubrication to the dist and cam gear. O-ring seals can be added to modified blocks to improve oil pressure control. Supplied with small, low crab style dist cap, rotor & bronze gear. Must be used with an MSD Crank Trigger & MSD Ign Control. No CARB Exemption Order Number.



Cap: MSD8541
Rotor: MSD8567

MSD8489...\$253.95

Crank Trigger Distributors

Designed to fit low in the block to clear firewall and intake combinations. CNC machined billet alum housing and Dupont Rynite base. Oversized polished steel shaft with a QPQ coating for friction reduction. Shaft is guided by a sealed ball bearing and an extra long sintered bushing. Special oil tract improves lubrication to the dist and cam gear. O-ring seals can be added to modified blocks to improve oil pressure control. Must be used with an MSD Crank Trigger and MSD Ignition Control. Supplied with large diameter, HEI style dist cap and rotor. Supplied with bronze gear. No CARB Exemption Order Number.



Cap: MSD8408
Rotor: MSD8457

Billet Crank Trigger Distributors:

Standard Chevy V8MSD84697...\$262.95
Tall Block Chevy V8 ...MSD8558\$319.95
Ford 351W.....MSD8378\$293.95
Ford 351W.....MSD8569\$275.95

Pickup Assembly, Non-Magnetic, 3/4"x16 UNF

They are engineered for extreme applications. In fact, this Pick-Up was designed and tested on 300+ mph top fuel dragsters! To live up to MSD's demanding expectations in these extreme applications, we took it upon ourselves to design and build the Pick-Ups in-house. This way we can control every aspect of their assembly and quality. Each Pick-Up is hand wound on a special bobbin and terminated to our tinned conductor, teflon jacketed wiring. These wires are also routed through a strain relief for protection. This assembly is then installed into the precision housing and is potted with a fracture resistant epoxy compound.



MSD8276...\$85.54

Compact Non-Magnetic Pickups

The Non-Magnetic Pickups are available in two housing sizes. The 3/4" model is used with MSD's Flying Magnet Crank Trigger Kits. The 3/8" diameter Pickups are used with MSD's Sprint Car Crank Trigger Systems as well as the professional racing kits from RCD and PSI.

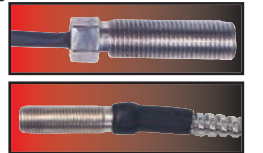

36" Shielded Harness

3/8" x 24 x 1.5".....MSD8159.....\$165.95

Small Armor Braided 32" Harness

3/8" x 24 x 1.5".....MSD8154.....\$199.95

Magnetic Pickup Assembly

This is a replacement pick-up for older style crank trigger systems that require a magnetic pick-up. This pick-up is magnetic and must be used with a trigger wheel equipped with steel studs to create a signal. The pick-up is .75" x 16" x 2.25".
MSD8505...\$126.95

Universal Crank Trigger Kit

This kit is supplied with everything you'll need to get you going in the right direction. A 7" billet aluminum wheel is supplied that has magnet positions for 4, 6, 8, 10 or even 12-cylinder engines. An oversized bracket arm is supplied that can be cut down to your specs and an "L" shaped holder is also supplied that can be machined for the 3/4" or 3/8" pick-up.
MSD8655...\$372.95



Flying Magnet Crank Trigger Kits

Absolutely the most accurate way to trigger the ignition. The non-magnetic pickup cannot be false triggered. Powerful magnets are embedded in a billet aluminum trigger wheel. Kits feature special brackets and mounting hardware for a variety of engines.



SBC, 6.25" Balancer.....MSD8600\$314.95
SBC, 7" Balancer.....MSD8610\$314.95
SBC, 8" Balancer.....MSD8615\$314.95
BBC, 8" Balancer.....MSD8620\$352.95
SB Chrysler, 7.25" Balancer.....MSD8633\$372.95
BB Chrysler, 7.25" Balancer.....MSD8636\$371.95
SBF, 289, 302, 351W, 6.562" Balancer.....MSD8640.....\$363.95
BBF, (except Cleveland block), 7.25" Balancer.....MSD8644.....\$363.95
Pontiac V8, 7" Balancer.....MSD8650.....\$372.95

Black Balancer Crank Trigger Kit

Each Flying Magnet Crank Trigger includes a two-piece mounting bracket for the non-magnetic pick-up that in most cases will work on either the passenger side or driver's side of the engine (the SB Chrysler and SB Ford brackets mount on only one side).



SBC 6.25"MSD86003.....\$314.95
SBC 7"MSD86103.....\$314.95
BBC.....MSD86203.....\$352.95

Racing Rotor MSD Billet Distributors

These rotors are designed with high rpm and performance in mind which is why they are standard on most MSD Pro-Billet Distributors. Both rotors are injection molded from Rynite material for incredible strength and high dielectric properties.

MSD8467...\$10.91

Fixed Rotor PN 8445

Band clamp mount allows easy rotor phasing adjustment. The only front drive distributor with adjustable belt tension. The MSD Cap and Rotor are injection molded from strong Dupont Rynite material. Billet aluminum bracket and lower housing for strength.

MSD8423...\$20.80

Bottom Rotor Square Drive

Molded from strong, durable Rynite material these rotors are designed specifically for MSD Crank Trigger Distributors. The rotor tip is secured with a screw for high rpm racing applications.

MSD8568...\$26.28

Rotor Phasing Kit for MSD Distributors

When you install EFI on your engine, most systems will require the ignition timing to be advanced for the ECU. This can cause issues with rotor phasing, but the new Adjustable Rotor remedies this issue! The rotor offers up to 20° of advance or retard and is easy to set up with accurate one degree detent adjustments.

MSD84211...\$38.35

Rotor & Base for Low Profile Distributors

MSD8457...\$35.06

Replacement Rotors

MSD Distributor Rotors are molded from high quality, voltage insulating material for resist carbon tracking while ensuring that the ignition spark reaches the spark plug terminals. For optimum voltage carrying capabilities the rotor tips are made from low resistance brass for maximum voltage transfer.

Rotors:

VW, MSD8485, & Ford 2.3L, MSD8473, Dist Only ...MSD8470\$15.31
GM and MSD HEI, OEMSD8410\$7.63

GM & MSD Small Cap EFI:

(MSD8366 and MSD8367)MSD8427\$12.01
Ford & MSD 5.0L Late Model.....MSD8070\$7.63
Ford Large Cap, Duraspark.....MSD8407\$9.82

MSD Timing Tapes

Accurate ignition timing is one of the most vital adjustments you can make to your engine. Proper timing can mean the difference between winning and losing a race or even blowing an engine (as a worst case scenario). Recognizing the importance of the timing, MSD offers these Timing Tapes.

It comes with eight different tapes to fit common balancers ranging from 5.25" to 8" diameter. The tapes are marked off in one degree increments from 14° ATDC to 64° BTDC and are printed on a tough, chemical resistant material.

MSD8985.....\$4.83

MSD GM LT1 Distributor Cap/Rotor

Finally a high quality Cap and Rotor for the front mount LT1 distributor! Also the all new cap housing is injection molded from a special DuPont material that provides strength and high dielectric properties resulting in less chance of breakdown causing a misfire.

LT1 Distributor Cap and Rotor Kit:

'93-94, with Fresh Air Vacuum Kit.....MSD8481\$170.95
'94-97MSD84811...\$167.95

Cap and Rotor Kits

The cap and rotor of any ignition system must be considered maintenance items. Just as you change the oil and filter of your car, you should always replace the cap and rotor as a set. To make things easy, we now offer these cap and rotor replacement kit.

GM V8 EFI, External CoilMSD8406...\$32.86
GM V6 EFI, 4.3L.....MSD8430...\$29.58
GM V8 HEI, Internal Coil, OE.....MSD8416...\$33.97
MSD/GM Points Style Socket Cap.....MSD8442...\$33.97

Ford V8 TFIMSD8482...\$36.89
Ford V8 DurasparkMSD8450...\$41.64
Ford V8 Duraspark with SpacerMSD8414...\$46.04

MSD Extreme HEI, Internal Coil.....MSD84023...\$72.82
MSD Cap (MSD8433) & Race Rotor.....MSD84335...\$40.54

Small Diameter MSD Cap (MSD8431) & Race Rotor..MSD84315...\$40.54
Large Cap Ford (MSD8408) & MSD RotorMSD84085...\$40.54

MSD84111

MSD84101

MSD HEI Components

MSD tooled up to produce the strongest HEI Cap available. The Cap and rotor will fit our HEI Pro Billet Distributor, MSD8365, plus will work on stock applications.

V8 HEI CapMSD84111\$47.14
Rotor.....MSD84101 ...\$17.51
Coil CoverMSD84022 ...\$33.97
Low Resistance Rotor Bushing...MSD8412\$13.11

Cap-A-Dapt Kits

If the new Pro-Cap doesn't work on your application, these MSD Cap-A-Dapts will do the trick. The MSD Cap-A-Dapt adapts a large, Ford style cap onto your MSD distributor.

Cap-A-Dapt, Fixed RotorMSD8445...\$60.31
Cap-A-Dapt, Small Dia Dist.....MSD8441...\$70.18
Cap-A-Dapt, w/Adjustable Rotor..MSD8420...\$66.53

Adjustable Race Rotor

If the new Pro-Cap doesn't work on your application, these MSD Cap-A-Dapts will do the trick. The MSD Cap-A-Dapt adapts a large, Ford style cap onto your MSD distributor.

Adjustable Race Rotor
(replaces Race Rotor MSD8467) ...MSD84211...\$38.35

Pro-Cap Cap-A-Dapt Kit, Fits MSD Dists

Five inch diameter and 2-inches between each terminal for improved voltage distribution. Injection molded from Rynite for incredible strength and dielectric properties. Plug Wire Retainer holds the wires securely in place. Rotor tip can easily handle high heat and is indexed and firmly secured with 2 screws.

MSD7445...\$108.95

Stock Style Cap and Rotor for GM Distributors

Stock Style ComponentsMSD8411\$33.97
Replacement Rotor.....MSD8410\$7.63
Stock Coil Cover.....MSD8402...\$21.90

Distributor Caps

All MSD Extra Duty Distributor Caps are designed with performance in mind and are molded from high quality, voltage insulating material and use low resistance terminals.

Chevy V8 Standard MSD8437 Socket
(use rotor MSD8467)MSD8437...\$27.38
Late Model HEI, External Coil (MSD8366)
(use rotor MSD8427)MSD8426...\$25.19

For MSD8485 VW Distributor
(use rotor MSD8470)MSD8434...\$20.80

Black Small Diameter Cap and Rotor Kit

The cap and rotor of any ignition system must be considered maintenance items. Just as you change the oil and filter of your car, you should always replace the cap and rotor as a set. To make things easy, we now offer these Cap and Rotor Replacement Kits.

Black Chevy V8 HEI Dist Cap and Rotor

The kit includes MSD Cap, MSD84333 and Race Rotor, MSD8467.

MSD84336...\$40.54

Black Small Diameter Cap and Rotor Kit

Kit contains Small Diameter MSD Cap, MSD84313 and Race Rotor, MSD8467.

MSD84317...\$40.54

GM Small Block Front Drive Dist.

Billet aluminum construction for strength and precise operation. Standard size Ford style cap features brass terminals and a wire retainer. Wide, 9mm belt for the most secure operation. Provisions for belt tension adjustments.

Pro Billet Front Drive Distributors:

Chevy Small BlockMSD8510**\$656.95**

Chevy Big BlockMSD8520**\$656.95**

(Will not fit raised cam big blocks such as Merlin, Donovan, Dart blocks or Gen VI.)



Cap: **MSD8408**
Rotor: **MSD8423**

Chevy V8 HEI Retainer Distributor Cap

If you are upgrading from a points socket style cap you will need to change your boots and terminals. MSD offers a set of nine as MSD8849.

RedMSD8433.....**\$39.45**



Ford HEI Distributor Cap

It has a provision for the coil wire to be routed in separately.

RedMSD8408.....**\$36.16**

BlackMSD84083.....**\$36.16**



Dist. Cap for PN 8570, 8545, 8546

MSD molds our most popular V8 distributor caps in-house. These caps are injection molded from DuPont Fynite material and feature spark plug-style terminals. These terminals offer improved locking connections.

RedMSD8431.....**\$39.45**

BlackMSD84313.....**\$39.45**



Crab Cap Distributor Cap

Crank Trigger distributor, use rotor MSD8567, Flat Top, and Flathead distributors, use rotor MSD84673.

MSD8541...**\$59.21**



Marine HEI Tower Cap w/Wire Retainer

MSD molds our most popular V8 dist caps in-house. These caps are injection molded from DuPont Fynite material and feature spark plug-style terminals. These terminals offer improved locking connections.

MSD8565...**\$42.33**



Starter Saver w/Signal Stabilizer

Compact unit provides 10° or 20° of start retard to ease pressure on the starter and flywheel during cranking. Plugs into an MSD Dist or Crank Trigger pickup. Built-in LED monitors trigger input signals. Built-in signal stabilizer produces steady timing at all rpm Unit is completely potted with Ciba polyurethane compound. Must be used with an MSD Ignition Control, magnetic pickup trigger and only on V-8 applications No CARB Exemption Order Number.

MSD8984...**\$133.95**



Start and Step Timing Control

This compact controller provides an adjustable start retard to help high compression engines crank over easily, plus has a single stage retard. The unit measures 2.75" x 2.37" x 1.25" and simply connects between the distributor and the MSD Ignition. Two rotary dials offer simple adjustments.

- Perfect for high compression nitrous cars.
- Compatible with 4, 6 or 8-cylinder engines.
- Accepts points, amplifiers and mag pickup trigger signals.
- Must be used with an MSD Ignition Control.
- Perfect for high compression nitrous cars.

MSD8987...**\$157.95**



Digital Multi-Retard

It provides four different stages of retard along with an adjustable start retard feature - all of this with no modules! The MSD Multi-Retard uses a high speed RISC microcontroller to direct the timing functions. This controller can make extremely quick compensations to the timing while maintaining accuracy to within 1°. There is also an innovative Magnetic Pick-Up Compensation circuit built-in to allow for rock-steady timing with a variety of different mag pick-ups. There are four separate retard stages that can be activated independently or together for a total sum of retards. Each stage is adj from 0° - 9° and a max of 20° of retard can be pulled out. On top of these great features, there is also an optional start retard circuit that can be programmed to retard the timing 5°, 10°, 15° or 20° during cranking. The Digital Multi-Retard can be used on 4, 6 or 8-cyl engines and must be used with an Ignition Control.

• 4 stages of retard • Magnetic pick-up compensation circuit • Adjustable start retard
MSD8975...**\$285.95**



Three Stage Retard Control

It allows you to retard your ignition timing in 3 different stages. You can activate one retard for a nitrous stage and another at top end in high gear for more mph and still have another module left over for dual stage nitrous systems. When activated together, the retard amounts are cumulative so you get the total of the three. For example, if you pull 2°, then 4° on the second stage and another 2° at top end, the total retard is 8° (2+4+2=8). In addition to the individual retard stages, the Three Stage Retard Control has an optional start retard function that retards the timing 10° or 25° while cranking the engine. It connects easily to your MSD Ignition and can be triggered from points, electronic ignitions, crank triggers or magnetic pick-up dists. It is supplied with a 2°, 3°, and 4° module and must be used with an MSD 6, SCI, 7, 8 or 10 Series Ignition.

MSD8970...**\$260.95**



Selector Switch

The Retard Module Selectors allow you to select between 12 retard amounts with the turn of a dial. The Selectors plug into the retard module receptacle of any MSD Timing Controls.

0°-11°MSD8676.....**\$83.35**



Module Kits

MSD Retard Module Kits give you a full selection of retard modules to be used with your Timing Controls.

1°, 2°, 3°, 4°, 5°MSD8777...**\$33.97**

5°, 6°, 7°, 8°, 9°, 10°MSD8776...**\$36.16**

11°, 12°, 13°, 14°, 15°MSD8774...**\$33.97**

16°, 17°, 18°, 19°, 20°MSD8775...**\$33.97**

Zero Degree ModuleMSD8773...**\$6.54**



Rubber Module Holder

The MSD Module Holders are exactly what you need to keep track of your MSD RPM or Retard Modules. Available in two styles: machined from a solid piece of aluminum or a new flexible plastic piece.

- Keep your rpm and timing modules organized.
- Durable flexible material keeps its shape and form.

MSD87551...**\$19.70**



Boost Timing Master for use w/MSD Ignition Control

It allow you to adjust the amount of ignition retard from 1" per pound of boost to 3" per pound via a control knob that you mount on the dashboard. This way you can make adjustments on the fly to prevent detonation as fuel quality or altitude and air quality changes up to a maximum of 15° retard. You can also set a boost pressure point to start the retard. There is a boost pressure port to connect to your manifold and the BTM wires easily to the MSD Ignition Control. Adjust the timing from the drivers seat. Easily connects to your MSD Ignition. New feature allows you to set a boost pressure point to start the retard!

MSD8762...**\$337.95**



Programmable Fuel Pump Voltage Booster

The updated Fuel Pump Booster is an easy way to maintain the proper fuel pressure on your car after adding a power adder such as a turbo or supercharger. What is updated you say? The new model allows you to make your boost adjustments through a PC for improved control and accuracy. The Booster ensures that the engine receives the fuel it needs to make up for the increase in air being pumped into the intake manifold. It will increase the voltage to the factory fuel pump in proportion to manifold boost pressure in order to maintain the proper fuel delivery. The amount of increase is adj from a range of an additional 1.5- 22 volts up to 30 psi which can all be set & adjusted from your PC w/MSDs easy to use Windows based software. The MSD Booster will wire to the factory fuel pump relay or with a secondary booster pump. Maintains fuel volume in relation to boost pressure by stepping up the supply voltage to the electric fuel pump. Voltage output is adjustable up to 22 volts at 15 psi of boost. For use with stock electric fuel pumps or secondary booster pumps.

MSD2351...**\$442.95**



Pro Crimp Tool, Ratchet Action

It features interchangeable jaws allowing for a variety of different style crimps with one heavy-duty tool. The Pro-Crimp features a hardened steel frame with comfortable molded hand grips. The slick ratchet action provides secure, factory quality crimps every time. The Tool is supplied with precision crimping/stripping jaws for MSDs spark plug wire terminals.

MSD35051...**\$88.84**



Pin Crimp Dies

These dies are for use with Pro-Crimp Tool, MSD35051.

Amp PinMSD3506...**\$35.06**

Amp LugMSD3507...**\$35.06**

Plug WireMSD3508...**\$30.67**

WeathertightMSD3509...**\$46.04**

DeutschMSD3510...**\$46.04**

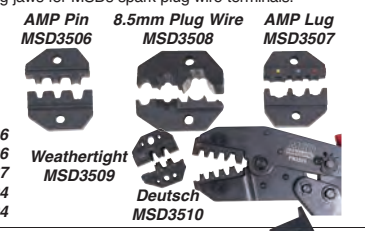

Mini Stripper Crimper

This special tool is an inexpensive way to make a set of custom plug wires. It provides a die to strip either 8mm Heli-Core or 8.5mm Super Conductor Wire, then can be used in a vise to provide a solid terminal crimp to the wire.

MSD3503...**\$9.82**



SmartSpark LS Ign Module for GM LS Series Engines*

It includes support for LS 1 version and for carbureted GM LS series V8 engines with 24 or 58 tooth crank trigger. The SmartSpark LS is a versatile ignition module for GM LS1/LS6 and LS2/LS7 race engines. Selection for GM LS1 or higher energy LS2 style coils. Preprogrammed with advance tables suitable for a wide range of normally aspirated high performance engines. Digitally set launch, burnout, and maximum RPM limits with 100 RPM steps from 3,000 to 9,900 RPM. Individual cylinder timing (ICT) capability with RPM based offset up to $\pm 5^\circ$ with 0.1° steps. Mode switch allows selection of basic functions. Advanced features require optional USB interface and PC Link software. Status LEDs show trigger inputs. Heavy duty 12 pin Deutsch connectors used for signal connections. Same mounting pattern as competitive units. New installations require wire harness depending on mounting location.



DAY119001 ..\$237.00...SmartSpark LS Ignition Module
 DAY119002 ..\$213.00...SmartSpark LS1/LS6 Remote Wire Mount Harness
 DAY119003 ..\$213.00...SmartSpark LS1/LS6 Manifold Wire Mount Harness
 DAY119004 ..\$72.00...SmartSpark LS Adapter Harness for MSD Upgrade
 DAY119005 ..\$213.00...SmartSpark LS2/LS7 Remote Mount Harness
 DAY119006 ..\$213.00...SmartSpark LS2/LS7 Manifold Mount Harness
 DAY119007 ..\$299.00...SmartSpark LS Ignition Kit (includes module & USB interface)
 DAY119008 ..\$89.00...1 Bar MAP Sensor (Delphi Gen 3 style for use w/SmartSpark)

DAY119100\$75.00SmartSpark Coil for GM LS2, LS3, and LS7 Engines
 DAY119100-8\$535.00SmartSpark Coil eight pack for GM LS2, LS3, and LS7 Engines



Programmable Data Logger with Shift Light

Ultra high brightness red/green/blue LED display that can be panel mounted or attached to a tach with a supplied bracket. The LED full spectrum color capability. Launch and multi-stage shift light capability. A launch RPM and up to five shift RPM levels can be defined to support up to six gear transmissions. Gear detection is based on vehicle speed or RPM drop during shift. Vehicle speed based gear detection allows use in applications other than drag racing as it allows correct gear sensing after downshifts. Launch detection is based on vehicle speed or a signal from a line lock solenoid. Two independent programmable alarm functions for analog inputs. Flexible RPM input compatible with high voltage coil drive, standard 12 volt tach signal, or low level logic drive. Built-in data logging. Ideal as basic vehicle data logger during dyno tuning or on the track. Logs data whenever system is armed. Stores last 5 minutes of data at 10 samples/second. Logged data includes throttle position, RPM, vehicle speed, status of all inputs and outputs, and two 0-5 volt analog inputs. Compact size: 3.3"L x 2.4"W x 1.1"H. USB interface to laptop PC. Powerful Windows software for programming controller and downloading logged data.



DAY117001 ..\$282.00...SL-1 Programmable Shift Light and Vehicle Data Logger

NC-1/NC-2 Nitrous Controller & Vehicle Data Logger*

They have identical features and capabilities except that the NC-2 can directly drive two nitrous stages with progressive control (modulated flow). The NC-1 requires external relays and is limited to on/off control. The NC-1 is recommended for applications under 100 horsepower. A progressive controller, such as the NC-2, pulse width modulates the solenoid valves and allows you to control the flow rate. The two primary applications for a progressive controller are matching nitrous system power output to vehicle requirements and independently controlling fuel and nitrous oxide flows for optimum air/fuel ratio (AFR). General purpose input/output (GPIO) terminal. Programmable for use as shift light output, additional stage enable input, or control output for ignition retard. Status LED output (ideal for use with arming switch containing LED). Built-in data logging. Ideal as basic vehicle data logger during dyno tuning or drag racing. Logs data whenever system is armed. Stores last 5 minutes of data at 10 samples/second. Data logged includes throttle position, RPM, vehicle speed, status of all inputs and outputs, and two 0-5 volt analog inputs. 0-5 Volt analog inputs are compatible with Daytona Sensors single or dual channel WEGO systems for logging wide-band air/fuel ratio data. Heavy duty industrial grade clamping terminal blocks allow easy and reliable hookup without soldering or crimping. Compact size: NC-1 is 3.3"L x 2.4"W x 1.1"H and NC-2 is 4.1"L x 2.8"W x 1.1"H. USB interface to laptop PC. Powerful Windows software for programming controller and downloading logged data. Please visit our website for complete details and downloads. Drives two nitrous stages and purge solenoid.



DAY116002 ..\$373.00...NC-2 Progressive Nitrous Controller and Vehicle Data Logger

CD-1 Capacitive Discharge Ignition System for Racing*

Complete capacitive discharge ignition system for racing. 135 MJ spark energy output. Digitally set launch, burnout, and maximum RPM limits with 100 RPM steps from 3,000 to 9,900 RPM (10,900 RPM for maximum RPM limit). PC programmable advance features ranging from a simple RPM based advance curve to a 3D timing map with boost proportional retard. Built-in data logging capability with 16 Mbit DataFLASH memory. Dedicated input terminals for launch RPM and manifold pressure. 12 pin Deutsch connector used for signal connections. Compact size. Module is 7.0"L x 5.25"W x 1.9"H. Coil is 4.4"L x 3.2"W x 3.0"H. Less than 5 amp current draw at 8,000 RPM.



DAY102002* ..\$114.50...CD-1 Ignition Coil
 DAY102003 ..\$595.00...CD-1 Capacitive Discharge Ignition System Kit
 DAY102004 ..\$79.95...USB Interface with 6 foot USB Cable and Software on CDROM
 DAY102005 ..\$42.50...RTD-1 Retard Control
 DAY102006 ..\$37.50...MAP Sensor Harness Kit
 DAY102007 ..\$49.00...Power Filter Capacitor Kit

DAY115011.....\$65.00.....1 Bar MAP Sensor (Delphi Gen 1 style for normally aspirated apps)
 DAY115012.....\$77.00.....2 Bar MAP Sensor (Delphi Gen 1 style for turbo/supercharged apps)
 DAY115013.....\$95.00.....3 Bar MAP Sensor (Delphi Gen 1 style for turbo/supercharged apps)



Wego3 Wide Band AFR Display

It includes WEGO III unit with 96" harness, Bosch LSU 4.2 oxygen sensor, 18 x 1.5 mm weld nut for exhaust pipe, and software on CDROM. Single and dual channel air/fuel ratio display systems with built-in data logging. Versatile tuning aid for all carbureted and fuel injected engines displays air/fuel ratio (AFR) and logs over 2 hours data including AFR, engine RPM, and a spare 0-5V analog input for sensors such as throttle position or manifold pressure. Wide supply voltage range from 11-16V allows operation from battery on small engines and race vehicles without an alternator. Current drain is approx. 1 amp per channel. Built-in USB interface. WEGO data logging software runs under Windows XP/ Vista/7/8. The software allows viewing & analyzing AFR, engine RPM and analog data with user defined scaling.



DAY112002 ..\$438.00...WEGO3 Wide-Band AFR Display (96" harness)
 DAY114001 ..\$438.00...WEGO4 Wide-Band AFR Display

WEGO Accessories & Replacement Parts

All WEGO systems use the Bosch LSU 4.2 wide-band exhaust gas oxygen sensor. Accessories & replacement parts listed below are suitable for use with all our WEGO systems.

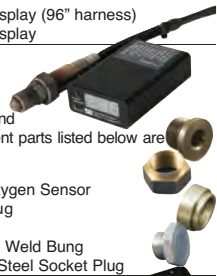

DAY115001 ..\$96.00...Wide-Band Exhaust Gas Oxygen Sensor
 DAY115002 ..\$6.50.....18 x 1.5 mm Hex Socket Plug
 DAY115003 ..\$6.50.....18 x 1.5 mm Weld Bung
 DAY115007 ..\$10.70.....18 x 1.5 mm Stainless Steel Weld Bung
 DAY115008 ..\$10.70.....18 x 1.5 mm Hex Stainless Steel Socket Plug

WEGO Dual Display Wide-Band Air/Fuel Ratio Meter (AFR) System

Complete air/fuel ratio (AFR) display system with built-in data logging. Includes WEGO III Dual Display unit, two Bosch LSU4.2 5-wire wide-band oxygen sensors, two 18x1.5mm weld nuts, and software on CDROM. Displays Lambda or correct AFR values for any hydrocarbon fuel with a known stoichiometric ratio. Versatile tuning aid for all carbureted and fuel injected engines displays AFR and logs over 2 hours data. Input for optional customer supplied flex fuel sensor. A switch under the sensor 2 LED allows selection of normal AFR display or 0-100% ethanol display. Can be used for on-road or dyno testing. Suitable for automotive, motorcycle, and other small engine applications. Easy free-air calibration procedure corrects for sensor aging effects. 0-5V analog AFR outputs for interface to dyno instrumentation. Wide supply voltage range from 11-16V allows operation from battery on small engines and race vehicles without an alternator. Size: 5.6"L x 3.2"W x 0.9"H.



DAY112005 ..\$585.00...WEGO3 Dual Channel Wide-Band AFR Display
 DAY113001 ..\$585.00...WEGO4 Dual Channel Wide-Band AFR Display

WEGO Wide-Band Air/Fuel Ratio (AFR) Interfaces

Complete air/fuel ratio (AFR) display system with built-in data logging. Includes WEGO III Dual Display unit, two Bosch LSU4.2 5-wire wide-band oxygen sensors, two 18x1.5mm weld nuts, and software on CDROM. Displays Lambda or correct AFR values for any hydrocarbon fuel with a known stoichiometric ratio. Versatile tuning aid for all carbureted and fuel injected engines displays AFR and logs over 2 hours data. A switch under the sensor 2 LED allows selection of normal AFR display or 0-100% ethanol display. Can be used for on-road or dyno testing. Suitable for automotive, motorcycle, and other small engine applications. Easy free-air calibration procedure corrects for sensor aging effects. 0-5V analog AFR outputs for interface to dyno instrumentation. Wide supply voltage range from 11-16V allows operation from battery on small engines and race vehicles without an alternator. Current drain is under 2 amps. Size: 5.6"L x 3.2"W x 0.9"H.



DAY111004 ..\$428.00...WEGO3D Kit (includes WEGO3D without display, 2 sensors and 2 weld bungs)

TC-1 Turbo Controller & Vehicle Data Logger*

Flexible turbo control system adaptable to most turbocharged vehicles. Open and closed loop control modes. Includes programmable duty cycle or boost curves based on RPM, vehicle speed and or time. Compatible with most boost control solenoid valves. Built-in 4-bar MAP sensor. User selectable units (psi, In-Hg, or kPa). Bright transreflective LCD display with backlight is readable in direct sunlight. Built-in data logging capability with 16 Mbit Data FLASH memory. Rates ranging from 2 samples/sec for 5 hours to 100 samples/sec for 6 minutes. Logs boost (MAP), RPM, vehicle speed, throttle position, solenoid duty cycle, battery volts, and two 0-5V analog inputs. 0-5V analog inputs are compatible with Daytona Sensors single or dual channel WEGO units for logging wide-band air/fuel ratio data. Programmable general purpose input/output can be used for an external scramble switch or to control a water/methanol injection system. Windows software for data logging and advanced setup functions. Size: 4-1/2"L x 3"W x 1"H.



DAY118001 ..\$324.95...TC-1 Turbo Controller and Vehicle Data Logger System

DAY118002 ..\$89.95...Boost Control Solenoid (for use with TC-1)

LED Timing Light for Dyno Apps

LED life estimated to be in excess of 400 hours with engine running at 1,500 RPM. Low cost capacitive spark pickup is used with conventional distributor, coil pack, or coil-near-plug ignition systems where a spark plug wire is accessible. Spark trigger sensitivity adjustment to accommodate different ignition energy levels while avoiding false triggering. Additional trigger inputs allow using the LED timing light with coil-on-plug ignition systems. Logic level (0-5V) trigger input allows triggering from coil drive signal for coil-on-plug ignitions with integrated coil drivers. LED lamp has 15" flexible gooseneck with 1/8-27 NPT male thread that allows easy mounting and alignment on any dyno frame. Size: controller is 3.3"L x 2.1"W x 0.9"H and LED lamp is 1.5" OD x 1.9"L. Operates from 12 VDC.



DAY120001 ..\$350.00...LED Timing Light (includes controller, LED lamp & capacitive spark pickup)



Launch Rev Limiter Switch Box

This handy controller lets you change the launch rpm setting instantly for last second changes in track conditions. They plug into the RS232 computer harness and have two rotary dials for adjustments. Instantly changes the launch RPM setting of the Programmable Controls. Two control dials, one for 1,000 RPM and another for 100 RPM. Adj from 3,000-12,500 RPM in 100 RPM increments. Can only be used with programmable MSD Ign Controls and Accessories. MSD7551...\$128.95



Spark Plug Wire Sync Kit

This pick-up simply installs to the number one sparkplug wire and senses the trigger signal and sends this information to the Ignition through a fiber optic cable. For cylinder per cylinder management. MSD7555...\$106.95



2-Step Rev Control for Digital 6AL

For use with Digital 6AL PN 6425 only. Since the new Digital 6AL Ignition uses rotary dials to adjust the rev limiter, our engineers were tasked with developing a 2-Step Rev Control that could be added to give racers the ability to switch to a low rpm limit to use on the starting line. The new 2-Step is also digitally controlled and connects to the Digital 6ALS gray tach output wire. There are two easy to read rotary dials that let you set the launch rpm in 100 rpm increments. There is an activation wire that connects to the transbrake, a clutch switch or to the line-lock to activate the low rpm limit. When that switch is released, the low rpm limit is turned off and the car launches hard! MSD8732...\$104.95



Two Step Module Selector

They allow you to choose two or three different rpm limits that can be activated at different times. With this ability, the possibilities are endless. As an example, we'll use a drag car with a Three Step Module Selector plugged into the rpm socket of a 7AL-2 In. The different rpm modules are activated when 12 volts are applied to a corresponding wire. By connecting one wire to the line-lock circuit, one module will be activated during the burnout. This helps keep tire temps consistent. When the line-lock button is released, the limit turns off. When you're on the starting line, you can activate the second limit through the clutch or trans switch. When no modules are selected, the remaining high limit is active to protect the engine in the event of driveline failure. The Two Step works the same, but only with two different limits. 2-Step Module SelectorMSD8739.....\$88.84 3-Step Module SelectorMSD8737.....\$99.82



Launch Control Module Selector

To help drag racers achieve even more consistency, our engineers have incorporated an adjustable low rpm stage into a Three Step Module Selector! This allows you to make adjustments in 100 rpm increments from the driver's seat! The Launch Control Module features a shielded harness for increased protection against EMI so it can be mounted within easy reach of the driver. The Launch Control also features two other rpm limits; one for top end over rev protection and another to use during the burnout to achieve consistent tire temperatures. These limits are adjustable with MSDs plug-in modules. No rpm modules are supplied. MSD8735...\$206.95



Adjustable RPM Module

With this module, the user can dial-in any rpm between 1,000 and 3,000 rpm by simply turning a potentiometer. Ideal for vehicles with automatic trans that are using the MSD Two Step Module Selector to leave the starting line below 3,000 rpm. MSD8677...\$28.48



RPM Module Selectors

- 3,000-5,200 rpmMSD8670\$73.48
 - 4,600-6,800 rpmMSD8671\$73.48
 - 6,000-8,200 rpmMSD8672\$73.48
 - 7,600-9,800 rpmMSD8673\$83.35
- *Not legal for use or sale on pollution controlled vehicles.



Tach Signal GMR Pickup

Clip to a coil packs voltage wire to produce a common 12-volt signal for a tach, shift light or rpm device. Connect to a diesel injector wire to provide an easy tach installation. Operates with 5-24 volt input for universal applications. MSD8918...\$63.59



Soft Touch Rev Control

It is designed to be used on std points ign or inductive ignition systems. It can be installed on engines with a GO HEI Ignition, Ford or Chrysler electronic ign, any std breaker points systems or even with an MSD 5 or Blaster Ign (non-CD igns). It is adjusted with plug-in modules & is supplied with 6,000, 7,000 and 8,000 rpm modules. When the engine reaches your set rpm, the Soft Touch circuitry kicks in & drops the spark to certain cyls. This limiter produces very accurate & smooth, backfire-free rev limits. MSD8728...\$149.95



MSD High Current Relay, SPST MSD8961

MSDs High Current Relays are what you need to activate accessories that draw high current. These Relays are very reliable due to the fully automated manufacturing process and sophisticated coil winding procedure. The SPST High Current Relay is rated at 30 amps with an input voltage of 12 volts DC. The relay is ideal for use with the MSD RPM Activated Switch when 12 volts are responsible for activating a high current device such as a nitrous solenoid. The DPST relay is also rated at 30 amps with a 12 volt input voltage. MSD8960



- Single Pole Double Throw 30 Amp/12 VDC...MSD8961.....\$32.86
- Double Pole Double Throw 30 Amp/12 VDC...MSD8960.....\$39.45

RPM Activated Switch

It will perform a variety of different functions from turning on a bulb or solenoid to activating an MSD Timing Control at a desired rpm. The RPM-Activated Switch, MSD8950, has two activation wires; one to ground a circuit and the other to open a circuit. Simply plug in an rpm module and wire the Switch to the circuit you want to activate. When the engine rpm reaches that amount, the circuit is activated and will remain on until the rpm falls below that amount. The RPM Window Switch, MSD8956, has 2 rpm adjustments; one to activate a circuit, while the other deactivates the same circuit. It will supply then remove ground to a circuit. Both Switches can be used with stock inductive ignitions or an MSD Ign and can handle up to 1.5 amps. For use on 4, 6, or 8-cyl. engines.



- RPM Activated SwitchMSD8950...\$113.95
- RPM Activated Window Switch ...MSD8956...\$105.95

Digital RPM Window Switch

This Switch will accept an input rpm signal from a coil negative terminal (for stock ignitions), a tach output from an ignition control, an ECU tach output or even a 5 volt tach signal. Another great feature is that no rpm modules are needed! The rpm activation points are programmed by simply scrolling through the LED display to your desired rpm amounts. The switch has two outputs; one Normally Open, the other is Normally Closed. It can be programmed from 200 rpm to 15,000 rpm in 100 rpm increments. It can be used with an input voltage of 9-18 volts. MSD8969...\$176.95



Digital Programmable Shift Light

Installs with distributors, coil packs or coil-on-plug systems ranging from single to 12-cylinders. Programmable from 100 - 15,900 rpm down to 10 rpm increments. Six bright LEDs are easy to view in daylight and can be dimmed at night. Supplied with an easy to install GMR pickup! Sync ShiftMSD8963\$182.95 Single RPM Point.....MSD89631\$186.95



Adjustable Intensity LED Shift Light

Pro Stock drivers were looking for a simple and small shift light that they could easily control the intensity of the LED. Easy enough. Here's the solution that plugs directly into our Programmable 7-Series Ignitions. MSD7542...\$85.54



MSD Shift Light

It will turn on to "remind" you to shift when the engine reaches your specified rpm. You select the rpm using the same plug-in modules that are used with your MSD Soft Touch Rev Control. It will work on 2, 4, 6, or 8 cyl engines and will plug directly into the tach output on MSD 6, 7, 8, and 10-Series Ignis or can be connected to the negative coil terminal when used with points or inductive-type ignitions. The MSD Shift Light is 4.5" L x 3.5" H with a 1.5" diameter lens. No rpm modules are supplied. MSD8952...\$132.95



Module Holders

The MSD Module Holders are exactly what you need to keep track of your MSD RPM or Retard Modules. Flexible Module HolderMSD87551\$19.70

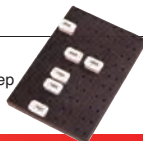



Module Bypass Cable GO HEI

The MSD GO HEI Module Bypass Cable Assembly allows you to plug an MSD 6 or 7 Series Ignition or Timing Accessory directly into the magnetic trigger inside a GO HEI distributor.

MSD8861...\$8.72



Noise Filter w/Cover

If you experience radio noise after installing the MSD Ignition, you may need to install an MSD Noise Filter. Electro Magnetic Interference (EMI) is occasionally generated from the MSD power cables and can be easily eliminated by installing the Noise Filter on the heavy power supply wires coming from the MSD. The Noise Filter will also prevent damage to the MSD during jump-starts and will keep a vehicles 12-volt line "clean" by removing any voltage and current surges that could interfere with the operation of some MSD accessories such as the Soft Touch Rev Control or the Two Step Module Selector.

MSD8830...\$47.14



Two Pin Connector Kit

It replaces damaged connectors or aids in custom wiring. This is the same connector used on MSDs magnetic pick-up harnesses. Each kit comes with 2 connectors and 4 pins.

MSD8824...\$7.63



Coil Ballast Resistor 0.8 ohm

For use with an MSD Blaster Coil when connected to a stock points ignition system.

MSD8214...\$10.91

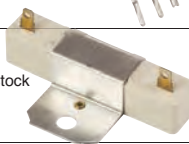

Tach Adapter

If after installing an MSD In Control, your tachometer, fuel pump relay or electronic fuel injection (in foreign vehicles) doesn't operate correctly, your application may require a Tach Adapter. This is due to the trigger signal not being strong enough to trigger both the MSD and the factories components. If you are triggering an MSD Blaster, 5, 6, SCI, or 7 Series In with its white wire or points terminal, you will need the PN 8910 Tach Adapter. It will correct the operation of most voltage-triggered tachometers or fuel injection systems that do not work directly off the tach output terminal of the MSD Ignition Unit.

MSD8910...\$55.91



Tach Adapter, Electronic Ignition System

If you are triggering an MSD Blaster, 5, 6, SCI, or 7 Series Ignition with its white wire or points terminal, you will need the PN 8910 Tach Adapter. The PN 8910 will correct the operation of most voltage-triggered tachometers or fuel injection systems that do not work directly off the tach output terminal of the MSD Ignition Unit.

MSD8910EIS...\$58.10



Deutsch Connector

There is absolutely no excuse for losing a race due to a poor wiring connection. MSDs Deutsch Connectors are sealed and lock together making them perfect for harsh racing applications. The compact housing of the connectors are molded from a durable plastic material that will not harden or crack. Each housing is indexed to prevent any chance of mismatching the ends plus they have a molded channel to secure another connector for a tidy appearance. The terminals grip to the wire with strong crimp tabs then lock into position inside the housing.

- 2-Pin Connector, 16 GaugeMSD8183.....\$10.91
- 4-Pin Connector, 16 GaugeMSD8181.....\$14.21
- 6-Pin Connector, 16 GaugeMSD8180.....\$20.80
- 8-Pin Connector, 16 GaugeMSD8185.....\$25.19
- 12-Pin Connector, 16 GaugeMSD8186.....\$29.58
- 2-Pin Connector, 12-14 GaugeMSD8184.....\$22.99
- 4-Pin Connector, 12-14 GaugeMSD8187.....\$48.23



Individual RPM Chips

- 5,800 RPM Chips .MSDASY11531..\$4.20
- 6,000 RPM Chips .MSDASY11216..\$4.20
- 6,200 RPM Chips .MSDASY11533..\$4.20
- 6,400 RPM Chips .MSDASY11535..\$4.20
- 6,600 RPM Chips .MSDASY11537..\$4.20
- 6,800 RPM Chips .MSDASY11539..\$4.20
- 7,400 RPM Chips .MSDASY11543..\$4.20
- 7,800 RPM Chips .MSDASY11547..\$4.20
- 8,200 RPM Chips .MSDASY11549..\$4.20
- 8,400 RPM Chips .MSDASY11551..\$4.20
- 8,600 RPM Chips .MSDASY11553..\$4.20

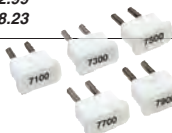

Tach Adapter, Magnetic Trigger

This will correct the operation of most tachs and fuel injection pump relays that do not work directly off of the MSD Ignitions 12 volt square wave tach output terminal. If, after installing an MSD In Control, your tach, fuel pump relay or electronic fuel injection (in foreign vehicles) doesn't operate correctly, your application may require a Tach Adapter. This is due to the trigger signal not being strong enough to trigger both the MSD and the factory's components.

MSD8920...\$72.38



Tach Driver, DIS Ignitions

The compact Tach Driver measures only 1.5" x 3.5" x 2" and is potted with a polyurethane compound for vibration and water protection so it can easily be mounted under the hood. It wires inline on the coils. 12 volt supply wire where it senses the current going through this wire and converts this information into a 12 volt output signal that most aftermarket tachs use as a trigger signal. It can be used on 4, 6 or 8-cyl engines.

MSD8913...\$93.22



Shielded Magnetic Pickup Cable, 6'

It will help protect the trigger signal from the distributor or crank trigger pick-up from Electro Magnetic Interference (EMI). The Harness is six feet long and is equipped with matching 2-Pin connectors. Recommended with MSD Digital Ignitions and aftermarket EFI racing systems.

MSD8862...\$33.97

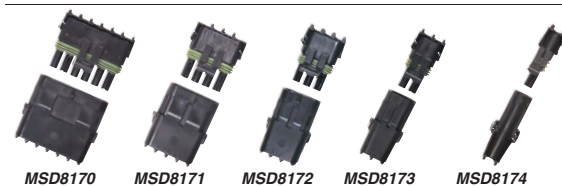

Weathertight Sealed Connectors

The connectors are molded from a special nylon material to withstand temps from -40° to +257° F and are indexed to prevent mismatching. For max electrical isolation, each terminal has its own tower so there is no chance of shorting between the wires. Each terminal tower utilizes self-lubricating silicone seals for protection against water, dust, oil, and other engine compartment fluids.

Male Tower/Female Shroud with Pins and Seals

- | Connector | Individual |
|-----------|----------------------|
| 6-Pin | MSD8170\$13.11 |
| 4-Pin | MSD8171\$12.01 |
| 3-Pin | MSD8172\$10.91 |
| 2-Pin | MSD8173\$9.82 |
| 1-Pin | MSD8174\$9.82 |



Universal, Push Button, Alternate Action Switch

This switch is designed to be used as an auxiliary ignition On/Off button. It can be mounted to the steering wheel within easy reach of the driver and can be used in a Normally Open or Normally Closed position. Assembled and constructed for harsh racing conditions.

MSD8812...\$83.35



Pin Extraction Tool

This tool allows you to remove the terminal from the Weathertight Connector if you need to make repairs or change your wiring.

MSD8193...\$19.70



- 10 Male Pins and SealsMSD8190.....\$10.91
- 10 Female Pins and Seals..MSD8191.....\$10.91

Spark Guard

Stops voltage leaks. Prevents moisture build-up. Eases boot assembly and removal 0.5 oz. of Spark Isolation Gel.

MSD8804...\$19.70



SPARK PLUGS



Popular High Performance Types

Chrysler, Ford, Chevrolet V6 and V8 w/alum. aftermarket cyl. heads Circle Track, Drag and Off Road racing. For compression ratios from 11:1 to 16:1. Also for use on big block cast-iron heads using 3/4" reach plugs. Used where piston dome & cylinder head modifications cause clearance problems between plug and piston top.

C Series	HOT	691	CHAM C63CX	\$.401
14mm Thread	↑ ↓ COLD	297	CHAM C61CX	\$.401
.750" Reach		296	CHAM C59CX	\$.401
5/8" Hex		295	CHAM C57CX	\$.401
		294	CHAM C55CX	\$.401
		293	CHAM C53CX	\$.401



Chrysler, Ford, Chevrolet V6 and V8 w/alum. aftermarket cylinder heads Circle Track, Drag and Off Road racing. For compression ratios from 11:1 to 14:1. For use on big block cast iron heads using 3/4" reach plugs

C Series	HOT	Stk NBR.....	Plug Type	
14mm Thread	↑ ↓ COLD	796	CHAM C63YC	\$.338
.750" Reach		794	CHAM C61YC	\$.338
5/8" Hex		792	CHAM C59YC	\$.338
		791	CHAM C57YC	\$.338

Ford & GO iron head big and small block. Also V6 and some aftermarket aluminum replacements for OE-designed cylinder heads. For compression ratios ranging from 11:1 to 15:1.

V Series	HOT	Stk NBR.....	Plug Type	
14mm Thread	↑ ↓ COLD	802	CHAM V63C	\$.350
.460" Reach		265	CHAM V63Y	\$.338
Conical Seat		263	CHAM V61	\$.338
5/8" Hex		670	CHAM V59C	\$.338
		672	CHAM V59YC	\$.338
		671	CHAM V57YC	\$.338

(3/8" reach, 14mm, flat gasket seat) Plug types fit 327 Chevrolet, Olds 400 and 455, Pontiac 350, 389, 400, 455, Chrysler 400, etc) with 11 to 13:1.

J Series	HOT	Stk NBR.....	Plug Type	
14mm Thread	↑ ↓ COLD	266	CHAM J63Y	\$.338
3/8" Reach		264	CHAM J61	\$.338
13/16" Hex				

General Guidelines for Heat Range Selection

Normally Aspirated, Gasoline Fueled

Compression Ratio	Recommended Heat Range
9:1-10:1	65-63
10.5:1-12.5:1	63-61
13.0:1-14.5:1	61-59
15:1-16:1	57-55
16:1 and higher	55-53



For alcohol fuels, mild turbo or supercharged and for oval track racing (1/2 mile track or longer), Drop 1 heat range cooler. For nitrous oxide fuel, severe turbo or supercharging, drop 2 or more heat ranges cooler.

Racing Spark Plugs

14mm	HOT	Plug Type	
3/4" Reach	↑ ↓ COLD	NGKR5671A-8.....	\$.194
5/8" Hex		NGKR5671A-9.....	\$.194
Solid		NGKR5671A-10.....	\$.195
Non-resistor		NGKR5672A-9.....	\$.194
Gasket seat			



14mm	• Projected Tip • Fits Many SBC • Crate Engines	Plug Type	
3/4" Reach		NGKTR5.....	\$.199
5/8" Hex		NGKTR6.....	\$.199
Taper Seat			



14mm	• Projected Tip • Fits Many SBC • Crate Engines	Plug Type	
.460 Reach		NGKR5673-8.....	\$.194
5/8" Hex		NGKR5673-9.....	\$.194
Taper Seat			



Thread.....14mm Hex.....Reach.....Style.....Part

5/8"460"	tapered ...	AUTLAR12.....	\$.294
5/8"460"	tapered ...	AUTLAR13.....	\$.294
5/8"460"	tapered ...	AUTLAR132.....	\$.356
5/8"460"	tapered ...	AUTLAR133.....	\$.356
5/8"460"	tapered ...	AUTLAR134.....	\$.294
5/8"460"	tapered ...	AUTLAR135.....	\$.294
5/8"750"	gasket	AUTLAR3910.....	\$.356
5/8"750"	gasket	AUTLAR3910X.....	\$.495
5/8"750"	gasket	AUTLAR3911.....	\$.356
5/8"750"	gasket	AUTLAR3932.....	\$.356
5/8"750"	gasket	AUTLAR3933.....	\$.356
5/8"750"	gasket	AUTLAR3933X.....	\$.495
5/8"750"	gasket	AUTLAR3934.....	\$.356
13/16"750"	gasket	AUTLAR50.....	\$.356
13/16"750"	gasket	AUTLAR51.....	\$.294
13/16"750"	gasket	AUTLAR52.....	\$.294
5/8"708"	tapered ...	AUTLAR93.....	\$.294
5/8"708"	tapered ...	AUTLAR94.....	\$.294



Spark Plugs

- Cut back ground electrode for improved ignition ability
- Anti-corrosive nickel plating
- Large ground electrode for better heat transfer
- Officially licensed spark plug of NASCAR
- Renowned Autolite quality

MOROSO

Ultra 40 Spark Plug Wires

The Most Powerful Wire Ever!

Highest spark energy transfer! Highest EMI/RFI suppression! Highest horsepower gain! Nickel copper conductor surrounds layers of ferrite impregnated core and Kevlar, protected by an extra thick EPDM layer and an 8.65 mm silicone jacket. No more powerful wire made.



Sleeved under header

SBC 90° non-HEI	MOR73605	\$.184.94 ea
SBC 90° HEI	MOR73607	\$.147.94 ea
BBC 90° HEI	MOR73616	\$.147.94 ea
BBC 90° non-HEI	MOR73617	\$.147.94 ea

Sleeved over header

SBC 90° non-HEI	MOR73600	\$.184.94 ea
SBC 90° HEI	MOR73602	\$.147.94 ea
BBC straight - Non-HEI	MOR73614	\$.147.94 ea
BBC straight - HEI	MOR73615	\$.147.94 ea

Universal Plug Wires

Blue Max Spiral Core Universal Sets

Kits come terminated at plug end, with enough wire to fit HEI or non-HEI distributors. Coil wires included where required.

90° Blue	MOR73225	\$.82.64
90° Red	MOR73219	\$.82.64
90° Black	MOR73231	\$.82.79
Straight Blue	MOR73226	\$.82.64
Straight Red	MOR73218	\$.82.64
Straight Black	MOR73232	\$.82.79



Blue Max Spiral Core Pre-Made Sets

8mm silicone. Insulated sleeve runs full length. Shrink tube sealed boots, and numbered ID tags. Race wire kits do not include coil wires.

SBC - HEI Type Terminals

90° plug terminals. Over Valve Covers	
MOR72402	\$.130.07

Under Headers	
MOR72407	\$.130.07

SBC - Non-HEI Type Terminals

Under Headers	
MOR72405	\$.130.07

BBC - HEI Type Terminals

90° plug terminals. Under Headers	
MOR72416	\$.130.07

Straight Terminals. Over Valve Covers	
MOR72415	\$.130.07

Ford 351W - HEI Style Terminals

135° plug terminals	
MOR72426	\$.162.59

Coil Wire Kits

3 feet of Spiral Core wire, a wire stripping tool, and a thirteen piece boot and terminal kit.	
MOR73235	\$.17.60

Spark Plug Wires

Its extremely low-resistance combined with the ability to suppress Electro Magnetic Interference is a combination that defies the common laws of physics. Less resistance means more energy is going to make it to the spark plug to ignite the air/fuel mixture. The Super Conductor uses a copper alloy conductor resulting in less than 50 ohms per foot of wire! This ensures that the most energy possible makes it to the spark plug. By helically winding the conductor around a special core, we are able to produce a highly effective choke to keep the EMI inside the wire and away from other electronics. This combination is encased in a heavy duty sleeve that will withstand abrasion and high temperatures. Cap off each end with our Dual Crimp Terminals and you have the best wire available. Equipped with high temp silicone-fiberglass sleeving for the harshest race conditions that protects wires up to 1,000 °F.



SBC Over Valve Cover, HEI	MSD31351	\$.148.95
SBC Over Valve Cover, Socket	MSD31651	\$.148.95
SBC Under Exhaust, Socket	MSD31591	\$.148.95
SBC Under Exhaust, HEI	MSD35591	\$.148.95

Universal Wiring Sets

Black Wires Part Number ends with a 3. • Red Wires Part Number ends with a 9. Dist cap boots and terminals are included so you can cut the wire to the desired length, than install the terminal with the supplied Mini-Stripper-Crimper.

A.) The MSD Universal Replacement wire is 48" long and has a multi-angle terminal and boot on one end with a 90° HEI style terminal on the other side. A 90° socket terminal and boot is also supplied with a Mini-Stripper-Crimper so the wire can be custom tailored to your application.

8 Cylinder Engine (Black).....MSD31183.....**\$100.95**
8 Cylinder Engine (Red).....MSD31189.....**\$100.95**

B.) For engines with Late-Model type (HEI "spark plug top") distributor caps (Ford Duraspark or MSD Cap-A-Dapt). 90° spark plug boots installed with 90° distributor boots and terminals included.

8 Cylinder Engine (Black).....MSD31223.....**\$99.82**
8 Cylinder Engine (Red).....MSD31229.....**\$99.82**

C.) For Late-Model GO LT1 Engines, this set comes with the LT1 Boots and Terminals installed and 90° spark plug boots and terminals loose.

8 Cylinder, Straight LT1 Boot (Red).....MSD32129.....**\$155.95**
8 Cylinder, 90° LT1 Boot (Red).....MSD32139.....**\$155.95**

E.) For GO Gen-III engines such as the LS1 or LS6, these wires are perfect when you relocate the coils. Both 90° and MA boots supplied.

LS Engines (Black).....MSD32073.....**\$170.95**
LS Engines (Red).....MSD32079.....**\$171.95**

F.) For Ford fans, these wires are designed for Ford Modular engines.

Ford Modular, 4.6/5.4L DOHC (Red).....MSD31889.....**\$176.95**

G.) Designed for the Chevy Pro Stock head, these 8.5mm wires incorporate a special boot for the spark plug. Ninety degree boots and terminals are supplied to be installed on the dist side.

Chevy Pro Stock Head (Red).....MSD30839.....**\$121.95**

H.) The new Ford & Chrysler Hemi style cyl. heads being used in Pro Stock racing features a long, skinny tunnel to access the spark plug.

New injection molded tubes are designed specifically for these hard to reach plugs.
Ford & Chrysler Hemi Pro Stock Head (Red).....MSD31539.....**\$211.95**

Two-In-One Universal Wire Sets



To cover all your bases, these wire sets are supplied with both the boot and terminals that fit older, socket style distributor caps, as well as the ones for spark plug-style terminals.

A.) Set includes terminals for engines with early type (socket) and late type (HEI "spark plug top") distributor caps. Multi-angle boots and terminals factory installed on one end.

4 Cylinder Engine (Red).....MSD31159.....**\$93.22**
6 Cylinder Engine (Red).....MSD31179.....**\$95.41**
8 Cylinder Engine (Black).....MSD31193.....**\$108.95**
8 Cylinder Engine (Red).....MSD31199.....**\$108.95**

B.) Set includes terminals for engines with early type (socket) & late type (HEI "spark plug top") dist caps. 90° boots & terminals factory installed on one end.

8 Cylinder Engine (Black).....MSD31233.....**\$108.95**
8 Cylinder Engine (Red).....MSD31239.....**\$108.95**

Replacement Super Cond. Plug Wire, Universal

The MSD Universal Replacement wire is 48" long and has a multi-angle terminal and boot on one end with a 90° HEI style terminal on the other side. A 90° socket terminal and boot is also supplied with a Mini-Stripper-Crimper so the wire can be custom tailored to your application.

Red.....MSD34069.....**\$30.67**
Black.....MSD34063.....**\$30.67**

HEI Coil Wire, Blaster 2 Super Conductor

18" long, Blaster Socket terminal and boot on one side with a Distributor Cap Socket Terminal and Boot on the other.

Red.....MSD84039...**\$16.42**

Black.....MSD84033...**\$17.51**

Blaster Socket Boot, Red...MSD84049...**\$17.51**

Pro Stock HEMI Tubes

It accessories for Ford & Chrysler Hemi Pro Stock engines. These engines heads have a long, skinny tube machined in the head to access the spark plug. This narrow passage makes it considerably difficult to install spark plug wires. MSD answers with a new injection molded spark plug wire boot that reaches down to securely connect the wire to the spark plug. The set of eight includes the tubes and components to assemble the wire for an easy installation. Included set of 8 tubes
MSD3476...\$89.94

100 Qty Bulk Boots and Terminals are Available!



Race Tailored Wire Sets

The MSD Race Tailored Heli-Core and 8.5mm Super Conductor Wire Sets are designed specifically to fit race engines equipped with headers or an MSD Distributor.

Pre Assembled!! Boot Description by Cylinder

Cyl.	Description	Style	Part #	Boot	Coil Wire
8 cyl All SBC w/Low Profile Distributor	MSD84697, 84997, 8558 (wires below header/exh manifold)	90°	MSD31243... \$83.35 MSD31249... \$83.35	B, D	B, D
8 cyl All BBC w/Low Profile Distributor	MSD84697, 84997, 8558 (wires below header/exh manifold)	90°	MSD31293... \$100.95 MSD31299... \$100.95	B, B	B, B
8 cyl All SBC w/new CrabCap MSD8541 with HEI terminals	(wires below header/exh manifold)	HEI	MSD30479... \$115.95	B, G	B, G
8 cyl All BBC w/new CrabCap MSD8541 with HEI terminals	(wires below header/exh manifold)	HEI	MSD30829... \$115.95	B, G	B, G
8 cyl All SBC w/Socket Dist Cap	(wires below header/exh manifold)	Socket	MSD31593... \$106.95 MSD31599... \$106.95	B, C	C, F
8 cyl All SBC w/HEI style Dist Cap	(wires below header/exh manifold)	HEI	MSD35599...\$94.32	Typical	Mod
			MSD35593... \$94.32	B, D	D, F
8 cyl All BBC w/Socket Dist Cap	(wires below header/exh manifold)	Socket	MSD31609... \$113.95	B, C	C, F
8 cyl All BBC w/HEI style Dist Cap	(wires below header/exh manifold)	HEI	MSD35609...\$97.62	Typical	Mod
			MSD35603... \$97.62	B, D	D, F
4 cyl Volkswagen Wire Set	for VW Billet Dist, MSD8485	90°	MSD31939... \$66.89	D, H	D, F

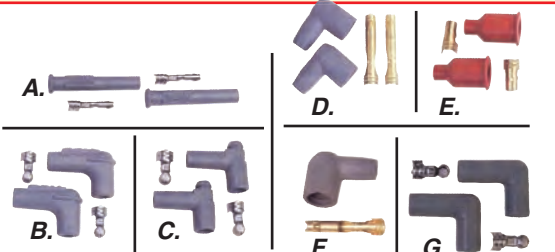

Replacement Boots and Terminals

MSD boots are designed with longevity in mind. Each boot provides excellent heat resistance as well as maximum protection against spark loss.

A. Multi-Angle Boots and Terminals, 2/Card.....MSD3301...**\$6.54**
B. 90° MSD Boots and Terminals, 2/Card.....MSD3311...**\$9.82**
C. HEI Style 90° Boots and Terminals, 2/Card.....MSD3320...**\$7.63**
D. 90° Socket Boots and Terminals, 2/Card.....MSD3321...**\$7.63**
E. Straight Socket Boots and Terminals, 2/Card.....MSD3322...**\$8.72**
F. Blaster 2 Coil Boot and Terminal, 1/Card.....MSD3331...**\$6.54**
G. 90° Non-Logo Boot and Terminal, 2/Card.....MSD3323...**\$8.72**
LT1 Straight Boot and Terminal, 2/Card.....MSD3302...**\$16.42**
LT1 90° Boot and Terminal, 2/Card.....MSD3303...**\$21.90**
LT1 45° Boot and Terminal, 2/Card.....MSD3304...**\$9.82**
90° Socket Boots and Brass Terminals.....MSD8851...**\$16.42**
90° MSD Boots and Dual Crimp Terminals.....MSD8850...**\$24.10**
90° Boots and Dual Crimp Terminals.....MSD8847...**\$16.42** **Sets**
HEI Boots for Retainers and Dual Crimp.....MSD8849...**\$15.31** **of 8**
Short 90° Boots and Dual Crimp Terminals.....MSD8848...**\$19.70**

Professional Racing Boots for Extreme Racing

Using a proprietary blend of materials, the boots can handle much higher temps over an increased amount of time. Proprietary rubber compound has a higher devulcanizing rating. Composition absorbs less infrared radiation

90° Pro Temp Boots
 2 per Card.....MSD3325.....**\$10.91**
 Pack of 8.....MSD8852.....**\$20.80**

Straight Boots
 2 per Card.....MSD3327.....**\$12.01**
 Pack of 8.....MSD8854.....**\$25.19**

115° Pro Race Boots
 2 per Card.....MSD3326.....**\$13.11**
 Pack of 8.....MSD8853.....**\$25.19**





DuraFire HEI Dists

- High-Output Module.
- Mechanical Advance Curve Kit.
- High-Output ProCoil & Cover.
- HEI Cap & Rotor.
- Available W/Without Adjustable Vacuum
- Advance HEI Cap & Rotor



MOR72231...\$243.96

Universal Wire Looms

Includes four 2-hole looms, two 3-hole looms, and four chrome brackets which secure to valve cover bolts.

- | | |
|--------|--------------------|
| Blue | MOR72150 |
| Red | MOR72151 |
| Yellow | MOR72152 |
| Black | MOR72153...\$12.88 |



Four Hole Looms

Includes 2 chrome plated brackets and 2 4-hole looms.

- | | |
|--------|-------------------|
| Blue | MOR72180 |
| Red | MOR72181 |
| Yellow | MOR72182 |
| Black | MOR72183...\$6.87 |



Under Header Loom

Includes four chrome brackets, two 4-hole looms, two 2-hole looms, two 4-hole separators, two 3-hole separators, two 2-hole separators and mounting bolts.



Black...MOR72195...\$26.28

Insulated Wire Sleeves

25' length of fiberglass impregnated with silicone for 8000 volts of added insulation. Seal ends with shrink sleeves.

MOR72000...\$70.40



Shrink Sleeves, numbered for easy spark plug identification. Includes 2 per cyl.

MOR72020...\$8.05

Blue Max Shrink Sleeves

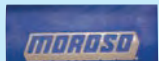

Insures a complete seal between spark plug, distributor boots and spark plug wire sleeve #s 72000, 72002, 72004 or 72011. Packaged 18 shrink sleeves to a set.

Blue...MOR72030...\$19.54

Advance Curve Kits



Recurve your dist for full advance at the optimum rpm. Included weights, centerplate and 3 sets of springs. Special design prevents weight from going "over center".

All GO HEI Adv. Curve KitMOR72300...\$11.17
'57-'75 GO/Delco non-HEIMOR72310...\$10.36



Replacement Distributors Parts

Moroso/GO HEI Dists GO H.E.I. V8

Coil Cover: Precision molded from advanced polymers for longer life and protection

MOR97858...\$12.85

Cap, Rotor and Brush Kit.MOR97859...\$32.15

Billet Hold Down

Firmly locks distributor while allowing easy timing changes.

MOR26215.....\$66.80



Distributor Hold Down Clamps

Extra thick and strong. Slotted for quick distributor removal. Includes stud, washer and nut to eliminate thread wear in manifold.

Gold Iridite SteelMOR26200.....\$10.76

Chrome Plated Steel...MOR26210.....\$10.76



Timing Indicator

Quickly adjust timing without the use of a timing light. Now anodized blue

MOR26100.....\$32.50



Distributor Gear Shim Kit

Allows precise adjustment of distributor shaft end play to improve timing accuracy and reduce gear wear. Works with GO, Accel, Chrysler, Moroso and other distributors with 1/2" diameter shaft. Includes two .010" shims, two .020" shims and one .053" shim

MOR26140...\$5.40



Distributor Housing Shim Kit

Eliminates oil pump bind & spark scatter when using a decked block or manifold. Contains .030", .060" & .100" shims.

MOR26150...\$4.42



Plug Indexing Washers

30 per pack, 10 of each size.

Tapered Seat .010", .021", .032"

MOR71900...\$19.39

Flat Seat .043", .050", .064"

MOR71910...\$19.39



Magnifying Flashlight

MOR62348\$38.02



Spark Plug Indexer

MOR62160\$11.07



Ford Modular Ign Controller for 4.6L/5.4L

Fire the coils & control the timing on Ford Modular engines with carbs. Map a timing curve and vacuum advance to meet your vehicle's needs. Program two rev limits and set a step retard for nitrous use. Connects directly to the coils, crank, cam & MAP sensors for an easy installation.

MSD6011...\$468.95



6-Hemi Ignition Controller

• Great for Nitrous • Does NOT control fuel. Hemi fans old and new will be excited to see that the 6-Hemi Controller will connect to factory EFI fueled Hemis or will drive the coil packs of a carb retro-fit engine! It is designed to operate with both styled coil packs that are offered on the new engines. A wiring harness for each app is sold separately. Fits 03-08 5.7 - Will not fit 6.1L

MSD6013...\$549.95



Chevy HEI Performance Distributors

Fit SBC and BBC (except 348 and 409). Housings are CNC-machined 6061-T6 aluminum with an upper support bearing to provide accurate timing at higher RPM. Include snap-on spark plug wire retainer and instructions.

HEI Distributor
w/Coil and Red CapALL81200 ..\$149.99
w/Coil and Black Cap...ALL81202...\$149.99



Seamless Heat Sleeve

1/4-1/2" x 3'THE14005...\$11.95

5/8-1" x 3'THE14010...\$15.95

Spark Plug Shield

4 pcs. 2 1/2" x 6" ...THE14250...\$31.95



Single Wire Timing Light

It is designed to work without an auxiliary power source which makes it ideal for use with magnetos for single wire hassle-free timing. Durable construction includes a rubber-encased lens and a 48 inch pick up lead. Longer leads are available for industrial apps.

- Replacement inductive pick-ups (FR1022) and xenon bulbs (FR1021) are available.
- State-of-the-art, 1 wire design (operates 2 D cell bats)
- Excellent for use with magnetos & all spark ignition sys.
- Bright xenon strobe clearly visible in daylight
- Accurate timing up to 14,000 RPM
- Can be used to test circuits

FLAFR1001.....\$64.09



Pro Timing Light

It is constructed with solid state circuitry and uses a Silicon Controlled Rectifier (SCR) that provides accurate and stable timing signals from 0 to 8,000 rpm. This rugged timing light is built to work in rough environments such as racing pits or professional mechanic shops. Its lightweight assembly is injection molded for great durability and produces an intense strobe that is easy to view even in daylight. The inductive pickup is detachable for easy storage and for safety measures while the battery clamps provide a strong grip to the terminals. The clamps are color-coded and insulated for tight, safe connections.

MSD8992....\$182.95

Self Powered Timing Light

The LW assembly is injection molded for great durability and produces an intense strobe that is easy to view through 5,000 rpm. Light uses (6) AAA batteries.

MSD8991....\$242.95



AIR FILTERS

14" Drop Base Air Filters - Chrome

Race ready low profile air cleaner. Drops filter 7/8" or 1-1/4" below carb flange. 5-1/8" flange fits all popular 4 barrel carbs. Note: 7/8" drop will fit carbs with electric choke mechanisms.



1-1/4" Drop Base

Neck.....Element.....Complete.....Total	Flange.....Height.....Element.....Assy.....Height
5-1/8".....3".....K&NE-1650..\$62.99.....K&N60-1280..\$95.99.....2.75"	
5-1/8".....4".....K&NE-3750..\$64.99.....K&N60-1290..\$130.99.....3.75"	
5-1/8".....5".....K&NE-3760..\$73.99.....K&N60-1300..\$125.99.....4.75"	
5-1/8".....6".....K&NE-3770..\$88.99.....K&N60-1310..\$123.99.....5.75"	

7/8" Drop Base

5-1/8".....3".....K&NE-1650..\$62.99.....K&N60-1430..\$116.99.....3.12"
5-1/8".....4".....K&NE-3750..\$64.99.....K&N60-1440..\$118.99.....4.12"
5-1/8".....5".....K&NE-3760..\$73.99.....K&N60-1450..\$127.99.....5.12"
5-1/8".....6".....K&NE-3770..\$88.99.....K&N60-1460..\$129.99.....6.12"

14" Air Filters - Chrome

Raises element 9/16" above carb flange. 5-1/8" flange fits all popular 4 barrel carb. 4 elements heights to fit a wide variety of apps. Will clear HEI dists.



Neck.....Element.....Complete.....Total	Flange.....Height.....Element.....Assy.....Total Height
5-1/8".....2-5/16".....K&NE-3740..\$67.99.....K&N60-1263..\$118.99.....3.87"	
5-1/8".....3".....K&NE-1650..\$62.99.....K&N60-1264..\$104.99.....4.62"	
5-1/8".....4".....K&NE-3750..\$64.99.....K&N60-1260..\$134.99.....5.62"	
5-1/8".....5".....K&NE-3760..\$73.99.....K&N60-1270..\$149.99.....6.62"	

Dominator Air Filters Chrome

These K&N 11", 14", & 16" outer diameter race ready air cleaners can flow the amount of air required for the Holley Dominator carburetors. 11" & 14" have 7-5/16" flange base and a 3/4" rise velocity stack. 16" has 1" drop base.



Neck.....Element.....Replacement.....Complete.....Total	Flange.....Height.....Filter.....Assembly.....Height			
11" O.D. Air Filter				
7-5/16".....3-1/2".....K&NE-1250..\$70.99.....K&N60-1230..\$120.99.....4.50"				
7-5/16".....5".....K&NE-3680..\$73.99.....K&N60-1240..\$129.99.....6.00"				
7-5/16".....6".....K&NE-3690..\$77.99.....K&N60-1250..\$133.99.....7.00"				

14" O.D. Air Filter

7-5/16".....4".....K&NE-3750..\$64.99.....K&N60-1235..\$158.99.....5.50"
7-5/16".....5".....K&NE-3760..\$73.99.....K&N60-1245..\$158.99.....6.50"
7-5/16".....6".....K&NE-3770..\$88.99.....K&N60-1255..\$163.99.....7.50"

16" O.D. Air Filter

7-5/16".....3-1/2".....K&NE-3804..\$84.99.....K&N60-1640..\$148.99.....3.25"
--

11" Air Filters Chrome

The perfect application for when space is a premium, yet high performance is required. Base is available in 3 flange sizes and various heights to fit a wide variety of applications.



Neck.....Element.....Complete.....Total	Flange.....Height.....Element.....Assy.....Height
5-1/8".....5".....K&NE-3680..\$73.99.....K&N60-1190..\$122.99.....6.00"	
5-1/8".....6".....K&NE-3690..\$77.99.....K&N60-1220..\$121.99.....7.00"	

11" Air Filter Top

Top Plate 11".
K&N06801.....\$16.90



11" Air Filter Base Plate

11" Diameter Air Filter Base. 4150 style 5-1/8" Carb Flange. Raises Assembly 9/16" Over Carb.
K&N01988.....\$20.16



Custom Air Filter Plates

K&N's 14" air filter plates are available separately for replacement or special applications. Base plates fit carburetors with 5-1/8" or 7-5/16" airhorn flange. Drop base will not clear all electric choke mechanisms, it may be necessary to space up baseplate with a locally available air cleaner spacer.



14" OD drop base, Chrome plated steel, 5-1/8" (drops filter 7/8" below carb flange)
K&N85-3545.....\$29.99

14" OD drop base, Chrome plated steel, 5-1/8" (drops filter 1-1/4" below carb flange)
K&N85-3549.....\$36.99

14" OD flat base, Chrome plated steel, 5-1/8" (raises filter 9/16" above carb flange)
K&N85-1541.....\$38.99

14" OD flat base, Nylon reinforced plastic, 7-5/16" (raises filter 3/4" above carb flange)
K&N85-3552.....\$65.99

14" OD top plate, Chrome plated steel, (center rises 1", stamped with K&N logo)
K&N85-6842.....\$31.99



Replacement Air Filter Elements

11" O.D. Air Filter

3-1/2" Element Height.....K&NE-1250..\$70.99
5" Element Height.....K&NE-3680..\$73.99
6" Element Height.....K&NE-3690..\$77.99

14" O.D. Air Filter

3" Element Height.....K&NE-1650..\$62.99
4" Element Height.....K&NE-3750..\$64.99
5" Element Height.....K&NE-3760..\$73.99
6" Element Height.....K&NE-3770..\$88.99



X-Stream Air Flow Tops

Not only does the XStream add filter area, it actually redirects airflow inside the filter to pull in more air through the side pleats for even greater performance efficiency. Cleanable & reusable.



X-Stream Air Flow Top Only

9" Dia.....K&N66-0901..\$64.99
11" Dia.....K&N66-1101..\$73.99
14" Dia.....K&N66-1401..\$70.99



11" Assemblies

Neck.....Element.....Complete.....Total	Flange.....Height.....Element.....Assy.....Height
5-1/8".....2-3/16".....K&NE-1200..\$71.99.....K&N66-3110..\$137.99.....3-1/2"	
5-1/8".....3-1/2".....K&NE-1250..\$70.99.....K&N66-3120..\$158.99.....4-3/4"	
5-1/8".....5".....K&NE-3680..\$73.99.....K&N66-3130..\$175.99.....6-1/4"	

9" Assemblies

5-1/8".....2-7/8".....K&NE-3530..\$48.99.....K&N66-3150..\$151.99.....4-1/2"
5-1/8".....3-3/4".....K&NE-3532..\$66.69.....K&N66-3160..\$159.99.....8-1/4"

14" Assemblies Standard 9/16" Raised Base

5-1/8".....2-5/16".....K&NE-3740..\$67.99.....K&N66-3000..\$170.99.....3-7/8"
5-1/8".....3".....K&NE-1650..\$62.99.....K&N66-3010..\$137.99.....4-5/8"
5-1/8".....4".....K&NE-3750..\$64.99.....K&N66-3020..\$182.99.....5-7/8"
5-1/8".....5".....K&NE-3760..\$73.99.....K&N66-3030..\$198.99.....6-7/8"

14" Assemblies 1-1/4" Drop Base

5-1/8".....3".....K&NE-1650..\$62.99.....K&N66-3040..\$127.99.....2-3/4"
5-1/8".....4".....K&NE-3750..\$64.99.....K&N66-3060..\$137.99.....3-3/4"
5-1/8".....5".....K&NE-3760..\$73.99.....K&N66-3070..\$183.99.....4-3/4"

7/8" Drop Base

5-1/8".....3".....K&NE-1650..\$62.99.....K&N66-3050..\$168.99.....3-1/8"
--

Dominator

7-5/16".....4".....K&NE-3750..\$64.99.....K&N66-3080..\$203.99.....5-1/2"
7-5/16".....5".....K&NE-3760..\$73.99.....K&N66-3090..\$208.99.....6-1/2"
7-5/16".....6".....K&NE-3770..\$88.99.....K&N66-3100..\$88.99.....7-1/2"

X-Stream Clamp on Filters

It provides awesome air flow and outstanding filtration. All K&N univ air filters are constructed with ultra-strong molded pliable rubber flanges which absorb vibration & allow for secure attachment & can also be stretched for up to 1/16" to fit in-between sizes.

Base Outside Diameter: 6"
Flange Inside Diameter: 2.5" Flange Length: 2"
Height: 6.5"
Top Outside Diameter: 5"
K&NRR-4860.....\$89.99



Base Outside Length: 4.75"
Base Outside Width: 3.75"
Flange Inside Diameter: 2.75" Flange Length: 0.813"
Height: 5.563"
Top Outside Diameter: 4"
K&NRR-5090.....\$105.39

Individual Round Style

Filters designed to fit with cut velocity stacks, or straight pieces of exhaust tubing. Rubber filter bases come with molded in velocity stack type radius and step, for smooth bore down from element to tube.

Flange Inside Dia: 2.5" • Flange Length: 0.625"
Height: 6" • Outside Dia: 3.5"
K&NRD-0720.....\$36.99



Individual Round Style

All filters are constructed with ultra-strong molded pliable rubber flanges which absorb vibration and allow for secure attachment and can also be stretched for up to 1/16" to fit in-between sizes.

Flange Angle: 20 degrees • Flange Inside Dia: 2.438"
Flange Length: 2" • Flange Type: Angled
Outside Diameter: 3.75"
4" Height.....K&NRU-1750.....\$36.99
5" Height.....K&NRU-1760.....\$40.99
6" Height.....K&NRU-1770.....\$37.99



Individual Round Style

Filters designed to fit with cut velocity stacks, or straight pieces of exhaust tubing. Rubber filter bases come with molded in velocity stack type radius & step, for smooth bore down from element to tube.

Flange Angle: 5 degrees • Flange Inside Dia: 3" Flange Length: 1"
• Flange Type: Angled Height: 5" • Outside Dia: 4.5"
K&NRB-0910.....\$40.99

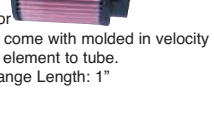



Flow Control Assy Filter Clips

They are designed for added support around the outside of the complete assemblies. Made of spring steel and black powder coated these Clip kits come in sets of 4.

- Flow Control 14" x 4.0" ...K&N85-83890\$20.46
- Flow Control 14" x 4.5" ...K&N85-83892\$21.79
- Flow Control 16" x 3.5" ...K&N85-83894\$20.69
- Flow Control 16" x 4.0" ...K&N85-83896\$21.62



Air Filter Sealing Grease

Hi-Temp. Grease won't run off. It seals against air leaks and also prevents dirt intake. Use whenever installing or replacing air filter element. Spread a liberal amount around rubber seal where it contacts air cleaner housing or air box. Don't use on "clamp-on" type filters.

- K&N99-0704\$9.64



2-Barrel Holley with and without choke tower

Fits the very popular 4412 Holley 2-barrel by removing the choke assembly & leaving the choke tower untouched. Gigantic increase in air flow and lots of horsepower. The small block with about 340-360hp can expect up to a 15-17hp increase. In the 400-420hp range the range increase climbs up to 20-22hp.

with choke tower

- 14" x 4.0"K&N61-2000\$259.99
- 14" x 4.5"K&N61-2010\$266.99

without choke tower

- 14" x 4.0"K&N61-2020\$268.99
- 14" x 4.5"K&N61-2030\$279.99

Fits 2 brl Holley with choke tower removed. Flows the same as 61-2000 and 61-2010.



Deflector Shield 14"

- 4.0"K&N85-54400\$81.99
- 4.5"K&N85-54450\$84.99

4-Barrel Holley with and without choke tower

with choke tower

For those of you who have not modified your choke tower, this is just the ticket for your bracket car or late model sportsman.

Fits 390-800

- 14" x 4.0"K&N61-4020\$280.99
- 14" x 4.5"K&N61-4030\$293.99

Fits 830-850

- 14" x 4.0"K&N61-4040\$258.99
- 14" x 4.5"K&N61-4050\$264.99

without choke tower

- 14" x 4.0"K&N61-4000\$280.99
- 14" x 4.5"K&N61-4010\$280.99



Replacement Air Filter Elements for Flow Control

All of the air cleaner assemblies listed were developed as complete kits. A lot of time and effort went into each combination of parts and dimensions for the intended carburetor.

- 14" x 4.0"K&NE-3730\$63.99
- 14" x 4.5"K&NE-3732\$83.99
- 16" x 3.5"K&NE-3804\$84.99
- 16" x 4.0"K&NE-3806\$107.39



Cleaner & Degreaser

It works to dissolve the dirt build up and old filter oil, and can be washed away with water. Complete instructions on bottle. NOTE: Do not use on polished or anodized aluminum.

- 32-oz. fl. squirt bottleK&N99-0621\$9.40
- 1-gallon refill bottleK&N99-0635\$22.72
- 5-gallon pailK&N99-0640\$83.99



Filtercharger Oil

It is the only oil specially formulated to work in combination with the cotton fabric in K&N Filtercharger elements providing a superior air filtration system. When used as directed, it quickly penetrates the filter pleats, where it remains suspended in the cotton fabric. Saturation is maintained until the element is cleaned with K&N Air Filter Cleaner.

- 12-oz. aerosol can - RedK&N99-0516\$6.67
- 8-oz. squeeze bottle - RedK&N99-0533\$4.70
- 1-gallon refill bottle - RedK&N99-0551\$28.99



Recharger Filter Care

Service Kit (Aerosol)

A 6-step maintenance system designed to clean any K&N Filtercharger Air Filter. Restores air flow efficiency so your Filtercharger performs like new! Includes: 6.5 oz. Spray Oil & 12 oz. Filter Cleaner Aerosol...K&N99-5000...\$10.31



(Squeeze Oil)

Same as K&N99-5000 but includes: 8 oz. Squeeze Oil & 12 oz.

- K&N99-5050...\$10.31



Steel Base Crankcase Vent Filters

Steel base crankcase vent filters have vent tubes added to their base. Filters consist of a one piece design with a rubber or chrome top. Filters with mounting studs can be mounted remotely, but require vent hoses and clamps.



Vent Rubber Top

Vent Diameter	Rubber Top Part #	
2" O.D.; 1 1/2" H		
3/8" O.D.	K&N62-1000\$19.53
1/2" O.D.	K&N62-1010\$19.53
1/2" O.D.	K&N62-1015 **\$23.20
1/2" O.D.	K&N62-1250 *\$24.99
5/8" O.D.	K&N62-1020\$20.46
3/4" O.D.	K&N62-1030\$19.53
1" O.D.	K&N62-1040\$24.99

Chrome Top with Stud Part

K&N62-1090\$21.37
K&N62-1100\$21.37
N/A	
K&N62-1300 *\$30.99
K&N62-1110\$28.99
K&N62-1120\$28.99
K&N62-1130\$28.99

3" O.D.; 2" H

Vent Diameter	Rubber Top Part #	
1/2" O.D.	K&N62-1050\$24.99
5/8" O.D.	K&N62-1060\$24.99
3/4" O.D.	K&N62-1070\$25.99
1" O.D.	K&N62-1080\$25.99

Chrome Top Part

K&N62-1140\$27.99
K&N62-1150\$27.99
K&N62-1160\$20.82
K&N62-1170\$21.85

Steel Base Crankcase Vent Filters with Shield

Zinc plated steel base plate with attached vent tube. Designed to push in to existing rubber breather grommets. All filters are 3" O.D. with deflector shields and 2 1/2" tall.



Grommet Size Part

1/2" I.D.	K&N62-1517	\$29.99
5/8" I.D.	K&N62-1518	\$29.99
3/4" I.D.	K&N62-1519	\$29.99
1" I.D.	K&N62-1520	\$28.99

Rubber Base Crankcase Vent Filters

Filters are designed to clamp directly to metal or plastic tubing. Ideal for engines, transmissions, oil and gas tanks on racing vehicles.



Flange Filter Filter Rubber Top

I.D.	Dia	Height	Part #	
5/16"	1 3/8"	1 1/8"	N/A	
9/16"	1 3/8"	1 1/8"	N/A	
3/8"	2"	1 1/2"	N/A	
1/2"	2"	1 1/2"	N/A	
5/8"	2"	1 1/2"	N/A	
3/4"	1 3/8"	1 1/8"	N/A	
3/4"	2"	1 1/2"	N/A	
3/4"	2"	2 1/2"	N/A	
1"	2"	1 1/2"	N/A	
1"	3"	2 1/4"	K&N62-1410\$19.53
1 1/4"	3"	2 1/2"	K&N62-1380\$20.88
1 3/8"	3"	2 1/2"	K&N62-1430\$20.76
1 1/2"	3"	2 1/2"	K&N62-1450\$19.53
1 3/4"	3"	2 1/2"	K&N62-1470\$19.53

Chrome Top Part

K&N62-2470\$20.52
K&N62-2480\$20.46
K&N62-1320\$18.50
K&N62-1330\$19.53
K&N62-1340\$19.53
K&N62-1560\$20.46
K&N62-1360\$18.50
K&NRU-3630\$39.99
K&N62-1370\$19.47
K&N62-1420\$23.20
K&N62-1390\$21.13
K&N62-1440\$21.01
K&N62-1460\$20.02

Rubber Base Crankcase Vent Filters with Shield

Universal "Clamp-On" for valve covers with existing vent tubes. All filters are 3" O.D. with deflector shields and 2 1/2" tall.



Vent Flange Dia	Part #	
1" I.D.	K&N62-1511\$26.99
1 1/4" I.D.	K&N62-1512\$26.99
1 3/8" I.D.	K&N62-1513\$26.99
1 1/2" I.D.	K&N62-1514\$24.99
1 3/4" I.D.	K&N62-1515\$26.99

Airforce Pre Cleaners

It is a specially designed foam filter wrap made to extend the service interval of your K&N Filtercharger when used in very dusty conditions.



Round Shape

3" ID x 2-1/2" HAll 3" OD x 2-1/2" H filters	K&N25-1480\$16.66
3-3/4" ID x 6" HAll 3-1/2" OD x 4" OD filters up to 6" long	K&N25-1770\$14.17
4-1/2" ID x 1-1/2" HRU-0330, RU-0340, RC-0330, RC-0340	K&N25-0330\$16.18
14" ID x 4" HAll 14" OD x 4" H filters	K&N25-3750\$29.99
14" ID x 5" HAll 14" OD x 5" H filters	K&N25-3760\$32.99
14" ID x 6" HAll 14" OD x 6" H filters	K&N25-3770\$37.99

Universal Shape

Cut to fit, secure with velcro strips (included)	
7" wide x 48" longK&N25-3900\$27.99
18" wide x 48" longK&N25-3918\$57.99
24" wide x 48" longK&N25-3924\$72.99
30" wide x 48" longK&N25-3930\$91.99



Air Filter Pre-Filters

They can extend the useful life of your filter by pre-filtering dust particles up to .005 in size. Made of a thin, durable polyester material for durability. Fits tightly over your filter and can improve its efficiency up to 50 percent, which also extends the life of your motor.

Air Filter Size	Color	No Top	With Top		
11 x 5	Black	OUT10-1197-01	\$19.95	OUT10-1198-01	\$23.45
	Blue	OUT10-1197-02	\$19.95	OUT10-1198-02	\$23.45
	Red	OUT10-1197-03	\$19.95	OUT10-1198-03	\$23.45
	Yellow	OUT10-1197-04	\$19.95	OUT10-1198-04	\$23.45
	Orange	OUT10-1197-05	\$19.95	OUT10-1198-05	\$23.45
Purple	OUT10-1197-07	\$19.95			
11 x 6	Black	OUT10-1199-01	\$19.95	OUT10-1252-01	\$23.45
	Blue	OUT10-1199-02	\$19.95	OUT10-1252-02	\$23.45
	Red	OUT10-1199-03	\$19.95	OUT10-1252-03	\$23.45
	Yellow	OUT10-1199-04	\$19.95	OUT10-1252-04	\$23.45
	Orange	OUT10-1199-05	\$19.95	OUT10-1252-05	\$23.45
14 x 3	Black	OUT10-1141-01	\$19.95		
	Blue	OUT10-1141-02	\$19.95		
	Red	OUT10-1141-03	\$19.95		
	Yellow	OUT10-1141-04	\$19.95		
	Orange	OUT10-1141-05	\$19.95		
14 x 4	Black	OUT10-1002-01	\$19.95	OUT10-1014-01	\$28.95
	Blue	OUT10-1002-02	\$19.95	OUT10-1014-02	\$28.95
	Red	OUT10-1002-03	\$19.95	OUT10-1014-03	\$28.95
	Yellow	OUT10-1002-04	\$19.95	OUT10-1014-04	\$28.95
	Orange	OUT10-1002-05	\$19.95	OUT10-1014-05	\$28.95
Purple	OUT10-1002-07	\$19.95			
14 x 5	Black	OUT10-1004-01	\$19.95	OUT10-1020-01	\$28.95
	Blue	OUT10-1004-02	\$19.95	OUT10-1020-02	\$28.95
	Red	OUT10-1004-03	\$19.95	OUT10-1020-03	\$28.95
	Yellow	OUT10-1004-04	\$19.95	OUT10-1020-04	\$28.95
	Orange	OUT10-1004-05	\$19.95	OUT10-1020-05	\$28.95
Purple	OUT10-1004-07	\$19.95			
14 x 6	Black	OUT10-1026-01	\$19.95	OUT10-1160-01	\$28.95
	Blue	OUT10-1026-02	\$19.95	OUT10-1160-02	\$28.95
	Red	OUT10-1026-03	\$19.95	OUT10-1160-03	\$28.95
	Yellow	OUT10-1026-04	\$19.95	OUT10-1160-04	\$28.95
	Orange	OUT10-1026-05	\$19.95	OUT10-1160-05	\$28.95

R2C Air Filter Pre-Filters - No Top

14" wide x 4" high	OUT10-2589-01	\$19.95
14" wide x 5" high	OUT10-2590-01	\$19.95
14" wide x 6" high	OUT10-2781-01	\$19.95

Crankcase Breather Pre Filters

Color	3 x 3 No Top	3 x 4 With Top	4 x 6 With Top
Black	OUT10-1018-01	OUT10-1052-01	OUT10-1049-01
Blue	OUT10-1018-02	OUT10-1052-02	OUT10-1049-02
Red	OUT10-1018-03	OUT10-1052-03	OUT10-1049-03
Yellow	OUT10-1018-04	OUT10-1052-04	OUT10-1049-04
Orange	OUT10-1018-05	OUT10-1052-05	OUT10-1049-05
Purple	OUT10-1018-07	OUT10-1052-07	OUT10-1049-07

\$12.95 \$12.95 \$12.95

Pro Flo Round Chrome Air Cleaners

Edelbrock triple chrome-plated round air cleaners work with all popular 5-1/8" diameter carbs (Performer Series, Thunder Series AVS, Holley, Thermo-Quad, Quadrajets & Carter AFB).

14" dia w/3" element (3-5/16")	EDE1207	\$32.95
14" dia w/3" element, 3/8" deeper flange (3-3/4")	EDE1221	\$31.95
10" dia w/2" element (3-1/2")	EDE1208	\$23.65
6" dia w/2" element, 5-1/8" base (3-5/8")	EDE1209	\$29.85
Air Cleaner Spacer (3/4")	EDE8092	\$7.44
Air Cleaner Spacer (1/2")	EDE8093	\$11.69

Air Filter Stud Kits

Keep your air cleaner firmly in position with an ARP stud kit. Includes your choice of a black oxide finished chrome moly or stainless steel stud with an appropriate nut. Vastly superior to the cheap fasteners that sometimes get used.

Size	Black Oxide	Stainless 300
1/4" x 2.225"	ARP200-0304 \$4.85	ARP400-0304 \$7.78
1/4" x 2.700"	ARP200-0305 \$4.99	ARP400-0305 \$7.89
1/4" x 3.200"	ARP200-0306 \$5.25	ARP400-0306 \$8.10
5/16" x 2.225"	ARP200-0301 \$4.85	ARP400-0301 \$7.78
5/16" x 2.700"	ARP200-0302 \$4.99	ARP400-0302 \$7.89
5/16" x 3.200"	ARP200-0303 \$5.25	ARP400-0303 \$8.10

Aluminum Air Cleaner Stud Kit

LW alum. Includes alum stud, thumb screw and air cleaner lid mount. Jam nut and mounting nut go under air cleaner lid so you can tighten the thumb screw without distorting the top.

5/16" Carb ThreadLON32750\$37.28
1/4" Carb ThreadLON32752\$37.28

Air Cleaner Stud Kit

It features a stainless steel threaded rod and is strong enough to handle the vibrations and the weight of the air cleaner. 2 tapered nuts improve airflow for added horsepower. The Tall Air Cleaner nut is o-ring sealed to keep dirt out.

Air Cleaner Stud Kit, 5/16"-18JOE34306\$34.95
Air Cleaner Stud Kit, 1/4"-20JOE34316\$35.95

Air Filter Pre-Filters

They can extend the useful life of your filter by pre-filtering dust particles up to .005 in size. Made of a thin, durable polyester material for durability. Fits tightly over your filter and can improve its efficiency up to 50%, which also extends the life of your motor.

Pre Filter	Color	With Top			
5" Fits K&N RU1760	Black	OUT10-1109-01 \$12.95			
5" Fits K&N RU1760	Blue	OUT10-1109-02 \$12.79			
Pre Filter	Color	With Top			
			4-1/2" Dia. • 5" Tall	Black	OUT10-1090-01 \$12.95
			4-1/2" Dia. • 5" Tall	Blue	OUT10-1090-02 \$12.79
4-1/2" Dia. • 5" Tall	Red	OUT10-1090-03 \$12.79			

Scrub Bag

- Shape: Round • Base Diameter: 14 inch
- Top Diameter: 14 inch • Height: 6 inch • Material: Denier Black...OUT30-1161-01...\$21.45

14" Air Cleaner Top

DIR5000BK.....\$29.99

Aluminum Air Cleaners

Low profile, spun alum air cleaners have 5-1/8" necks and O-ring spacers for a positive seal. Aluminum or black powder coated tops are available. Offset bases clear HEI dists. Elements sold separately.

Standard Height	Extra Height	
14" w/ 1/2" Spacer	ALL26094	\$57.99
14" Offset Base w/ 1/2" Spacer	ALL26095	\$57.99
16" w/ 1/2" Spacer	ALL26096	\$82.99
14" w/ 1/2" Spacer (Black)	ALL26097	\$61.99
14" w/ 1" Spacer	ALL26098	\$61.99
14" w/ 1" Spacer (Black)	ALL26099	\$67.99

Replacement Components

O-Ring For Spacers	ALL26084	\$3.99
1/2" Spacer and O-ring	ALL26085	\$11.99
1" Spacer and O-ring	ALL26086	\$13.99
1-1/2" Spacer and O-ring	ALL26087	\$17.99
14" Air Cleaner Top Black	ALL26088	\$25.99
14" Air Cleaner Top Plain	ALL26090	\$19.99
14" Bottom Offset	ALL26091	\$26.99
14" Air Cleaner Bottom	ALL26092	\$26.99
16" Air Cleaner Bottom	ALL26093	\$41.99

Air Cleaner Bottom, 2 BBL

14" overall dia. 5/8" drop, plain finish. 3" dia carb flange.
ALL26081\$28.99

Air Cleaner Adapter

With the use of this adapter you are able to use the more popular 4 bbl. air cleaner on a Rochester 2 bbl. carb. Street car owners are now able to accessorize with aftermarket air cleaners while retaining stock 2 bbl. carb. and intake. Classes requiring the use of a 2 bbl. can benefit from the higher flow of a 4 bbl. air cleaner. Made of high strength ABS plastic. Adapter has a 3" ID and a 5-1/8" O.D.
ALL26080\$16.99

Air Cleaner Spacer

1/2 in Tall, 5 1/8 in Neck, EachMRG9340\$8.83
1 in Tall, 5 1/8 in Neck, EachMRG9341\$8.83

Aluminum Air Cleaner Spacers

1/2" Spacer and O-ring ALL26085\$11.99
1" Spacer and O-ringALL26086\$13.99

Front Hood Scoops

Scoops are molded from durable high impact plastic with carbon fiber look and have a molded-in flange for easy mounting. Protect air cleaners from dirt and debris.

ALL23230 ALL23232
ALL23233 ALL23235

2.5" Tall, Tapered.....ALL23230 \$52.99
3.5" Tall, Tapered.....ALL23232 \$52.99
3.5" Tall, OpenALL23233 \$52.99
3.5" Tall, Straight.....ALL23235 \$52.99
5.5" Tall, StraightALL23237 \$56.99

Reusable Foam Filter Shield

When dirt and clay oval tracks turn into "dust bowls", even the best racing air cleaners can become clogged with dirt and dust. Made of open cell foam to keep large debris out of the filter element without restricting airflow. Can be cleaned in sink or in the washing machine. 1 per pkg. Fits 14" x 5" filters.
MOR65947\$14.01

DIRT Dish Seal

The recess in your air filter top does a good job of directing air under it into your carburetor...and also of collecting dirt. Stop it from falling into your carb with this handy plug, permanently bonded to the alum nut.

.250-20 Thread 1/4"SEACARB3001\$13.91
.312-18 Thread 5/16"SEACARB3002\$13.91

Air Filter Gaskets

Designed to fit under the air cleaner for most carbs. They will help prevent unfiltered air from entering your engine.

Holley, Carter, Q-JetFEL2104\$8.68
Dominator 4500FEL2105\$9.83

INTAKE MANIFOLDS

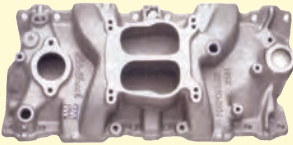

SBC 262-400 V8 Performer '86 & Earlier (idle-5500 rpm)

Designed for street '55-86 262-400 c.i.d. SBCs. EDE2101 is stock replacement / street legal part for 302, 327 and 350 V8s with OEM 4-bbl. or Edelbrock EDE1400 carb; '66-72 ('73 non-California) cars, '66-83 trucks & Suburbans; except stock equipped EGR. Performer (non-EGR).....EDE2101**\$182.85**
Polished Performer EDE2101 (non-EGR) EDE21011**\$446.55**



Performer RPM (1500-6500 rpm, non-EGR)

Designed for 1955-86, 262-400 c.i.d. Chevy V8's for max power & a broad torque curve for high perf street. EDE7101.....**\$217.49**



RPM Air-Gap (non-EGR)

Designed for 1955-86, 262-400 c.i.d. Chevy V8's, the RPM Air-Gap incorporates the same race-winning technology as the Victor Series competition intakes. EDE7501.....**\$278.49**



RPM Air-Gap 2-0 (1500-1600 rpm)

Designed for street 396-502 c.i.d. Chevy V8s with large oval-port cylinder heads ('75 & earlier) The air-gap design features an open air space that separates the runners from the hot engine oil resulting in a cooler, denser charge for more power. Includes rear water outlets, 2 distributor clamp locations & nitrous bosses. EDE7561.....**\$325.99**



Victor Jr. Manifolds

Small Block Chevy (not for use with 1987-up cylinder heads) For 4150/4160 Series Holley Square bore EDE2975.....**\$307.89**
Big Block Chevy 454 Series (Rectangular port heads) Standard flange 4-barrel EDE2902.....**\$354.05**



Super Victor Manifolds

SBC (for rpm from 3500 to 8000)
For heads with standard port location. Runners match "flat floor" area of latest 23° heads. EDE2925.....**\$331.95**



X-CEerator SBC V8

2000-6500 RPM power band. Single plane/open plenum design. No provision for divorced or hot air choke. Square flange carb mounting. '57-86; 262, 283, 305, 327, 350, 400 V8, '87-later w/alum heads WEI7547-1**\$200.95**



Fuel Pump Bolt Kits ARP

Make sure that mech fuel pumps stay properly aligned by using ARP's durable black oxide finished chrome moly or rust-proof stainless bolts (both materials are rated at 170,000 psi and considerably stronger than Grade 8 hardware). Washers are included.

Chevy Fuel Pump Bolt Kits

Black Oxide Hex.....ARP130-1602**\$7.43**
Black Oxide 12-Point...ARP130-1601**\$7.80**
Stainless 300 Hex.....ARP430-1602**\$9.01**
Stainless 300 12-Point.ARP430-1601**\$9.52**



Seals-it

Fuel Pump Seal

Keeps hot oil away from your pump. Keeps fuel cooler.



Chevy-Carter.....SEACHFP4002-C.....**\$38.95**
Chevy-Holley.....SEACHFP4002-H.....**\$38.95**

Fuel Pump Block-Off Plates

Designed to block off the fuel pump mounting boss when a mechanical fuel pump is not used. Available in 2 popular styles. Made of blue anodized aluminum or high luster triple chrome plated steel.

Black anodized alum, SBC.....MOR65391**\$7.54**
Chrome plated steel, SBC.....MOR65393**\$8.54**
BBC 273-440 Chrysler & all Fords exc. 351C, 351M & 400. Black anodized alum.....MOR65392**\$7.54**
Chrome plated steel.....MOR65394**\$7.54**

Billet Manifolds Peterson

Its feature all billet alum construction with an integrated mounting pad.

Y-Manifold 6 x 6 x 6.....	PET10-0030	\$107.49
Y-Manifold 8 x 6 x 6.....	PET10-0031	\$107.49
Y-Manifold 8 x 8 x 8.....	PET10-0032	\$107.49
Y-Manifold 10 x 8 x 8.....	PET10-0033	\$107.49
4 Way Mani 10 x 6 x 6 x 6.....	PET10-0034	\$107.49
4 Way Mani 6 x 6 x 6 x 6.....	PET10-0040	\$109.74
4 Way Mani 8 x 6 x 6 x 6.....	PET10-0041	\$109.74
5 Way Mani 6 x 4 x 4 x 4.....	PET10-0060	\$140.29
5 Way Mani 8 x 4 x 4 x 4.....	PET10-0061	\$149.00
5 Way Mani 10 x 8 x 8 x 8.....	PET10-0070	\$164.56
5 Way Mani 10 x 6 x 6 x 6.....	PET10-0071	\$164.56
5 Way Mani 12 x 8 x 8 x 8.....	PET10-0080	\$164.56
5 Way Mani 10 x 6 x 6 x 6.....	PET10-0081	\$164.56



SB Dirt Spec Manifold/Aluminum Head

BRDHV-1000.....**\$422.10**



Dirt Manifold Sportsman

BRDHV-1011.....**\$call**



SBC Intake Gaskets (2 per set)

Steel Core Laminate, 1.99 in. x 1.23 in. Port, .060 in. Thick FEL1204.....**\$16.04**
Printo seal, 2.09 in. x 1.28 in. Port, .060 in. Thick, FEL1205.....**\$16.29**
Printo seal, 2.21 in. x 1.31 in. Port, .060 in. Thick, FEL1206.....**\$18.16**
Composite, 2.110 in. x 1.08 in. Port, .120 in. Thick, Vortec, Set FEL1255.....**\$22.28**
Steel Core Laminate/Printo seal, 2.04 in. x 1.25 in. Port, .060 in. Thick, LT1 Chevy, L, Set FEL1284.....**\$23.11**
Composite, 2.21 in. x 1.31 in. Port, .120 in. Thick, FEL1266.....**\$23.27**



BBC Intake Gaskets (2 per set)

Composite, Oval, 2.05 in. x 1.82 in. Port, .060 in. Thick, Chevy, 396-454, Set.....FEL1210.....**\$24.76**
Printo seal, Rectangle, 2.54 in. x 1.82 in. Port, .060 in. Thick, Chevy, 396-454, Set.....FEL1211.....**\$19.45**
Marine Gaskets, Manifold, Intake, Printo seal, Rectangle, 2.54 in. x 1.82 in. Port, .060 in. Thick, Chevy, 396-454, Set.....FEL1211S-3.....**\$24.75**
Composite, Rectangle, 2.54 in. x 1.82 in. Port, .060 in. Thick, Chevy, 396-454, Set.....FEL1275.....**\$18.26**
Composite, Rectangle, 2.54 in. x 1.82 in. Port, .120 in. Thick, Chevy, 396-454, Set.....FEL1275S-3.....**\$31.57**



Intake Manifold Gasket Set

262-400 SBC Gen I 1955-91
Fits 1955-'91 SBC w/ Medium size ports. MRG106**\$23.23**



Intake Manifold Bolt Kits

3/8" dia, 12-point-headed intake manifold bolts simplify the job of installing and removing. Kits are manufactured of Grade 8 steel with gold iridite finish and come complete with close-tolerance washers. Intake Manifold Bolt Kit, Small Block and 90° Chevy V6, and SB Chryslers with single plane manifold, 3/8"-16 x 1-1/8", 12 to a set MOR38400.....**\$16.13**



Intake Manifold Bolts

SBC 265-400 - Stainless
uses 3/8" socket (Hex Set).....ARP434-2001.....**\$37.02**
uses 3/8" socket (12-Point Set) .ARP434-2101.....**\$39.31**
SBC 265-400 - Black Oxide
uses 3/8" socket (Hex Set).....ARP134-2001.....**\$21.87**
uses 3/8" socket (12-Point Set) .ARP134-2101.....**\$22.59**
BBC 396-454 - Stainless
uses 3/8" socket (Hex Set).....ARP435-2001.....**\$52.37**
uses 3/8" socket (12 Point Set) .ARP435-2101.....**\$54.41**
BBC 396-454 - Black Oxide
uses 3/8" socket (Hex Set).....ARP135-2001.....**\$28.77**
uses 3/8" socket (12 Point Set) .ARP135-2101.....**\$30.09**
SBF 289-351W - Stainless
uses 3/8" socket (Hex Set).....ARP454-2001.....**\$43.39**
uses 3/8" socket (12 Point Set) .ARP454-2101.....**\$47.05**
SBF 289-351W - Black Oxide
uses 3/8" socket (Hex Set).....ARP154-2001.....**\$30.90**



FUEL PUMPS

Holley

170+ GPH HP Series Mechanical Fuel Pump Street/Strip Carbureted Apps. Fits SBC V8s Compatible with Gasoline

HP series flow 170 GPH. Made from 6061-T6 billet aluminum for durability & good looks. HP series feature a CNC billet finish for good looks. Male -8AN inlet and outlet already installed. Preset Idle fuel pressure of 7.5 PSI. A/N fittings included with all pumps. Bases are independently rotatable from the top for ease of installation. No fuel pressure regulator required

HOL12-327-25.....\$331.95



170+ GPH HP Series Mechanical Fuel Pump Street/Strip Carbureted Apps Fits BBC V8s Compatible w/Gasoline

HP series flow 170 GPH. m for durability & good looks. HP series feature a CNC billet finish for good looks. Male -8AN inlet and outlet already installed. Preset Idle fuel pressure of 7.5 PSI. A/N fittings included with all pumps. Bases are independently rotatable from the top for ease of installation. No fuel pressure regulator required.

HOL12-454-25.....\$331.95



200+ GPH ULTRA HP Series Mechanical Fuel Pump

Race Carbureted Apps. Fits SBC V8s Compatible with Gasoline

Ultra HP series flow 200 GPH. Made from 6061-T6 billet aluminum for durability & good looks. Hard coat anodized for corrosion protection. Fittings included; -10 AN inlet and -8 AN outlet. Preset shutoff pressure of 10-11 PSI. Bases are independently rotatable from the top for ease of installation. Inlet and outlet are tapped 3/4-16 straight O-ring. Requires a fuel pressure regulator. Pump is completely rebuildable. Intended for hard core strip use or is perfect for use in circle track classes. Requires the use of a fuel pressure regulator such as Holley # 12-704.

HOL12-327-30.....\$543.95



200+ GPH ULTRA HP Series Mechanical Fuel Pump

Race Carbureted Applications. Fits SBC V8s Compatible with Alcohol

Ultra HP series flow 225 GPH. Made from 6061-T6 billet aluminum for durability & good looks. Hard coat anodized for corrosion protection. Fittings included; -10 AN inlet and -8 AN outlet. Preset shutoff pressure of 10-11 PSI. Bases are independently rotatable from the top for ease of installation. Inlet and outlet are tapped 3/4-16 straight O-ring. Requires a fuel pressure regulator. Pump is completely rebuildable. For use with Alcohol fuels. Intended for hard core strip use or is perfect for use in circle track classes. Requires the use of a fuel pressure regulator such as HOL12-704.

HOL12-327-35.....\$538.95

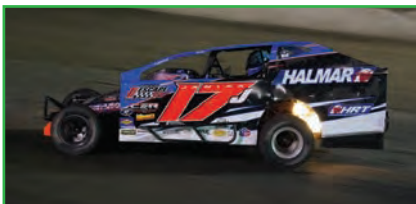

225+ GPH ULTRA HP Series Mechanical Fuel Pump

Race Carbureted Apps . Fits BBC V8s Compatible w/Alcohol

Ultra HP series flow 225 GPH. Made from 6061-T6 billet aluminum for durability & good looks. Hard coat anodized for corrosion protection. Fittings included; -10 AN inlet and -8 AN outlet. Preset shutoff pressure of 10-11 PSI. Bases are independently rotatable from the top for ease of installation. Inlet and outlet are tapped 3/4-16 straight O-ring. Requires a fuel pressure regulator. Pump is completely rebuildable. For use with Alcohol fuels. Intended for hard core strip use or is perfect for use in circle track classes. Requires the use of a fuel pressure regulator such as Holley part number 12-704.

HOL12-454-35.....\$532.95



150 GPH Billet Base HP Electric Fuel Pump

Flows 150 GPH Free Flow. Flows 140 GPH at 7 PSI. Powers Engines from Stock All the Way Up to 900 HP. 3/8" NPT Inlet and Outlet Fittings. Black Mil-Spec Nickel Teflon Hard Anodized Billet Base. Show Quality Chrome 12 volt Motor. Profiled Black Powdercoated Mounting Bracket. Laser Engraved Holley Logo and Inlet/Outlet Markings. Less Noise than Traditional Vane Pumps. 6-1/4" tall. Compatible with Gasoline or Alcohol.

HOL12-150..\$270.95



125 GPH Billet Base HP Electric Fuel Pump

Flows 125 GPH Free Flow. Flows 110 GPH at 7 PSI. Powers Engines from Stock All the Way Up to 700 HP. 3/8" NPT Inlet and Outlet Fittings. Black Mil-Spec Nickel Teflon Hard Anodized Billet Base. Show Quality Chrome 12v Motor. Profiled Black Powdercoated Bracket. Laser Engraved Holley Logo and Inlet/Outlet Markings. Less Noise than Traditional Vane Pumps. 6-1/4" tall. Compatible with Gasoline or Alcohol.

HOL12-125..\$245.95



HP Billet Carbureted By-Pass w/Idle Bleed Fuel Pressure Regulator

Street/Strip Carbureted Applications Two Port Adjustable from 4.5 to 9 PSI with Idle bleed

Adjustable from 4.5-9 psi for precise fuel pressure adjustments. Constructed of billet aluminum with a black anodized base and clear anodize top for good looks. Utilizes a idle bleed for precise control of idle pressure. Used in systems with a return line back to tank. Use with electric pumps only. One 3/8" NPT inlet, one 3/8" NPT outlet and one 3/8" NPT return (or bypass). 1/8" NPT gauge port. Comparable and interchangeable with popular Holley HOL12-803BP regulator. Mounting bkt included.

HOL12-842.....\$115.95



Billet Fuel Sample Valve

It is designed to simplify installation and make fuel checks a snap! Packed with common sense features, it's simply the best sample valve on the market. Installs into any 1/8 NPT gauge port. Provides a duplicate 1/8 NPT port on the valve for installation of fuel pressure gauge or pressure sensor transducer. Sample port is equipped with stainless steel barb fitting for extension hose and rotates 360° for ease of installation and sampling. The dual action, spring loaded safety valve keeps the valve sealed when unlocked and rotates into a locked position for racing. When a fuel sample is required, rotate to the unlocked position, press for fuel sample and release, re-lock the valve and go race.... AER15631...\$93.99



"Red" 97 GPH Electric Fuel Pump

Street/Strip Carbureted Apps Compatible w/Gasoline Only

Tumble polished billet look. for enhanced fuel flow and quiet operation. Max pressure is 7 psi. Motor draws 2 amps current. Relay kit HOL12-753 & 7 1/2 amp fuse recommended. Constant fuel flow with no pulsation. Improved design for street/strip app. Distinctive "Red" logo. Flows 97 GPH (free flow). Flows 71 GPH at 4 psi. regulator is not required. Has externally accessible pressure relief valve (max 7 psi). Rotor/vane pump design is more tolerant of contaminated fuels. Weighs only 2.88 lbs. Includes mounting bkt. Repair kits are readily available. Can be serviced from pump end. Not compatible with alcohol or methanol fuels. Use of safety shut-off switch, HOL12-810, strongly recommended. Not designed or recommended for use with fuel injection systems

HOL12-801-1.....\$127.95



110 GPH Blue Electric Fuel Pump w/Regulator

Street/Strip Carbureted Apps Gasoline Only

Tumble polished billet look. Lower housing casting designed for enhanced fuel flow and quiet operation. Motor draws only 3 amps current. Relay kit HOL12-753 & 7 1/2 amp fuse recommended. Improved design for street/strip apps. Flows 110 GPH (free flow). Flows 88 GPH at 9 psi. max pressure is 14 psi. Includes HOL12-803 fuel pressure regulator. Provides constant fuel flow with no pulsation. Has externally accessible pressure relief valve (max 14 psi). Rotor/vane pump design is more tolerant of contaminated fuels. Weighs only 3 lbs. Includes mounting bkt. Repair kits are readily available. Can be serviced from the pump end. Not compatible with alcohol or methanol fuels. Use of safety shut-off switch, HOL12-810, strongly recommended. Not designed or recommended for use with fuel injection sys.

HOL12-802-1.....\$152.95



110 GPH "Blue" Electric Pump w/o Regulator

Street/Strip Carbureted Apps Compatible w/Gasoline Only

Tumble polished billet look. Lower housing casting designed for enhanced fuel flow and quiet operation. Motor draws only 3 amps current. 7-1/2 amp fuse recommended. Improved design for street/strip apps. Flows 110 GPH (free flow). Flows 88 GPH at 9 psi. max pressure is 14 psi. Provides constant fuel flow with no pulsation. Has externally accessible pressure relief valve (max 14 psi). Rotor/vane pump design is more tolerant of contaminated fuels. Weighs 3 lbs. Includes mounting bkt. Can be serviced from the pump end. Not compatible with alcohol or methanol fuels. Use of safety shut-off switch, HOL12-810, strongly recommended. Not designed or recommended for use with fuel injection systems. Fuel pressure regulator not included.

HOL12-812-1.....\$144.95



140 GPH Black Electric Fuel Pump

Street/Strip Carbureted Apps Compatible w/Gasoline, Alcohol or Methanol

Tumble polished billet look. Lower housing casting designed for enhanced fuel flow and quiet operation. Improved design for street/strip apps. Compatible with alcohol or methanol fuels. Flows 140 GPH (free flow). Flows 120 GPH at 9 psi. Max pressure is 14 psi. 3/8" NPT inlet & outlet ports. Fuel pressure regulator is required (recommend Holley HOL12-704 for gasoline and HOL12-707 for alcohol). Motor draws only 4 amps current. Relay kit HOL12-753 & 7 1/2 amp fuse recommended. Provides constant fuel flow with no pulsation. Has externally accessible pressure relief valve max 14 psi. Rotor/vane pump design is more tolerant of contaminated fuels. Weighs only 3 lbs. Includes mounting bkt. Can be serviced from pump end. Safety shut-off switch, HOL12-810, strongly recommended. Not designed or recommended for use w/fuel injection system.

HOL12-815-1.....\$194.95



SBC Billet Alum Fuel Pump
Max GPM 90 for 850 HP Engine

8.5-9 PSI Idle	CVSPIN-MP-2509\$480.00
10.5-11 PSI Idle	CVSPIN-MP-2551\$492.95
16.5 PSI Idle	CVSPIN-MP-2512\$480.00



BBC Billet Alum Fuel Pump
Max GPM 90 for 850 HP Engine

9-9.5 PSI IdleCVSPIN-MP-2517\$456.00
10.5-11 PSI IdleCVSPIN-MP-2516\$479.36
16.5 PSI IdleCVSPIN-MP-2515\$483.00

SBF Cast Fuel Pump - 7 PSI

SBF 1/4" NPT In/Out
CVSPIN-MP-520\$155.95

SBF Steel -8 AN In/Out
CVSPIN-MP-5218\$186.95



SBC Cast Fuel Pump - 7 PSI

SBC Steel -10 AN In/8 AN Out.....CVSPIN-MP-504\$189.12
Replaces CATM4891-503D

SBC Steel -8 AN In/Out.....CVSPIN-MP-5048.....\$180.95
Replaces CATM4891-502D



BBC Cast Alum Fuel Pump
-10 Inlet -8 Outlet.....CVSPIN-MP-5120.....\$186.61

Steel Fuel Pump Fittings

-8CVSPIN-MP-386\$15.86
-10CVSPIN-MP-385\$15.86

Spring Diaphragm

7-7.5 psi	GreyCVSPIN-MP-2534\$23.67
8.5-9 psi	GreenCVSPIN-MP-2536\$23.67
9-9.5 psi	BlueCVSPIN-MP-2534\$23.67
10.5-11 psi	WhiteCVSPIN-MP-2535\$28.70
16-16.5 psi	RedCVSPIN-MP-2634\$25.86

Replacement Parts

Std Valve Kit Delrin ValveCVSPIN-MP-2635\$83.79

Gasket Kit, Billet Fuel Pump.....CVSPIN-MP-2540\$call

Black Oxide Bolt Kit Billet FP.....CVSPIN-MP-2541\$call

SBC Arm Kit w/Cam Lever

Control Spring.....CVSPIN-MP-2542-S\$call

BBC Arm Replacement KitCVSPIN-MP-2546\$call

SBF Arm Replacement Kit w/Lever

Control Spring.....CVSPIN-MP-2543-S\$call

Holley Mechanical Fuel Pump
80+ gph. 1/4" NPT inlet/outlet.

SBCHOL12-834\$88.60
BBCHOL12-835\$88.60



Holley 110+ gph. 3/8" NPT inlet/outlet.

SBCHOL12-327-11\$100.95
BBCHOL12-454-11\$111.95



Holley 130+ gph. 3/8" NPT inlet/outlet.
Extra strength rocker arm and casting. Shut-off pressure pre-set to 8 psi.

SBCHOL12-327-13\$113.95
BBCHOL12-454-13\$110.95
SBFHOL12-289-13\$130.95 CRATE

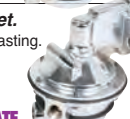

Holley 170+ GPH pumps 3/4"-16 inlet & outlet Needs -8 Port Fitting.

SBCHOL12-327-20\$144.95
BBCHOL12-454-20\$150.95



Common Fittings

-8 x 3/4-16 (AN-8)EAR985008\$10.51
-10 x 3/4-16 (AN-8)EAR985009\$13.20



Victor Series Racing Fuel Pumps
High-volume 3/8" NPT inlet and outlet orifices surpass the capacity of conventional models. Produces 10 psi and must be used with an external fuel pressure regulator such as our Fuel Pressure Regulator #8190 or #1727. For gasoline only. Clockable lower housing can be rotated for best inlet/outlet alignment.

SBCEDE1711\$132.95
BBCEDE1712\$140.15
289-351W FordEDE1715\$138.15



Holley Fuel Pump Check Valve Kit
Fits HOL12-801-1 "Red" Electric Fuel Pump

Check valve kit for 12-801-1 fuel pump. Includes lower gasket, check valve, spring and inlet screen filter.
HOL12-805.....\$14.36



Fits HOL12-802-1 & HOL12-812-1 "Blue" Electric FP

Check valve kit for 12-802-1 or 12-812-1 fuel pump. Includes lower gasket, check valve, spring & inlet screen filter.
HOL12-806.....\$14.36



Fits HOL12-815-1 "Black" Electric FP

Check valve kit for 12-815-1 fuel pump. Includes lower gasket, check valve, spring and inlet screen filter.
HOL12-816.....\$38.73



Electric FP Service Kits Rotor and Vane Kit
for HOL12-801-1, HOL12-802-1 Pump

HOL12-811\$20.75
-----------	--------------



PRO/CAM RACING ENGINE COMPONENTS Mechanical Fuel Pumps

SBC 7 1/2" PSI, 6 ValvePRC9351\$139.95 CRATE
BBC 7 1/2" PSI, 6 ValvePRC9370\$163.95
BBC 11" PSI, 6 ValvePRC9371\$167.95
BBC 15" PSI, 6 ValvePRC9372\$171.95



QUICK FUEL TECHNOLOGY 500 CFM Q-Series Replacements for 4412 500 CFM Gauge Rule

CT: Sportsman style carb that will pass most tech inspection depending on rules - please check with your sanctioning body before purchase. Features modified emulsion and wedge float.
QUIQ-500-CT\$493.95

CTA: Setup for alcohol fuel - features stainless hardware, billet metering block, and wedge float.
QUIQ-500-CTA\$556.95



Q-Series Circle Track Carburetors

Built tough to withstand the rigors of round track racing these carbs will take whatever is thrown at them and ask for more. With several sizes and variations there is sure to be carb listed that will help make the checkered flag a reality.

650 GasolineQUIQ-650-CT\$738.95
650 AlcoholQUIQ-650-CTA\$770.95
750 GasolineQUIQ-750-CT\$813.95
750 Annular BoostersQUIQ-750-ANCT\$843.95
750 AlcoholQUIQ-750-CTA\$843.95
850 GasolineQUIQ-850-CT\$843.95
850 Annular BoostersQUIQ-850-ANCT\$939.95
850 AlcoholQUIQ-850-CTA\$897.95
950 3 Circuit CalibrationQUIQ-950-CT\$897.95
950 3 Circuit Ann BoostQUIQ-950-CTA\$949.95



Performer RPM Street Fuel Pumps

It improves flow quantity and quality, and will support engines up to 600 hp. High-volume, 3/8" NPT inlet and outlet surpasses the capacity of conventional models. Produces 6 psi and does not require a regulator. For gasoline only. Clockable lower housing can be rotated for best inlet/outlet alignment.

SBCEDE1721\$128.85
BBCEDE1722\$136.05
429/460 FordEDE1726\$164.95

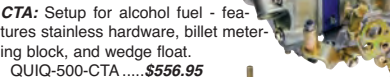

Dead Head Regulator

LW: Designed with the latest in CAD software, the SPIN Regulator is the lowest mass compact regulator on the market. Low Pressure Drop: High Flow design eliminates pressure variations. Pressure Fluctuation: Less than 1/2 pound and has Zero "Creep". Fast Response: LW moving parts enables an ultra fast pressure response. Durable: Hard coated to resist wear, made with top quality components. 2 Gauge Signal Ports: Configure gauge to read either low or high pressure. Far superior to any other Regulator on the market today. Made in the USA.

CVSPIN-MP-1000\$294.95
----------------	---------------



Adjustable By-Pass Regulator

LW: Designed with the latest in CAD software, the SPIN Regulator is the lowest mass compact regulator on the market. Low Pressure Drop: High Flow design eliminates pressure variations. Fast Response: LW moving parts enables an ultra fast pressure response. Durable: Hard coated to resist wear and top quality components. Two Gauge Optional Ports: Configure gauge to read either low or high pressure.

CVSPIN-FR-2000\$213.95
----------------	---------------



Fuel Log w/ Dead Head Regulator

9.5"CVSPIN-MP-1000-4150\$339.95
9.75"CVSPIN-MP-1000-4150ULTRA\$352.42



Fuel Log w/ Adjustable By-Pass Regulator

9.5"CVSPIN-MP-2000-4150\$270.95
------	--------------------------	---------------



Carburetor Holley Fuel Pressure Regulators

3/8" NPT ports .220" (7/32") restriction. Includes mounting bracket. Low Pressure (1-4 PSI). High Pressure (4-1/2-9 PSI)

HOL12-803Standard\$32.08
HOL12-804Low Pressure\$32.08



Diaphragm Repair Kit
for HOL12-803 & HOL12-804.

HOL12-807\$7.16
-----------	-------------



Carb Fuel Pressure Regulators

Regulates from 4-1/2 to 9 PSI. One 1/2" NPT inlet and two 1/2" NPT outlet ports. 0.437" (7/16") restriction. Includes mounting hardware and AN style fittings (one -8 and two -6). Alcohol compatible.

HOL12-704\$111.95
-----------	---------------



Carburetor Bypass Style Fuel Pressure Regulator

3/8" NPT ports. (1 in, 1 out, 1 bypass or return) Used in system with a return line back to the fuel tank. Quieter fuel pump operation. Designed only for carb use. Preset to 7 PSI. Adj from 4-1/2 to 9 PSI. Electric fuel pumps only.

HOL12-803BP\$84.16
-------------	--------------



Billet Regulator Bkt

Mounts to a HOL12-803, HOL12-804, HOL12-500, HOL12-501 or HOL12-803BP fuel pressure regulator utilizing the passenger side Carb studs on any 4150/4160 style carb. Universal design fits Holley and competitors 4150/4160 style carbs.

HOL20-120\$39.89
-----------	--------------



EDE1791 Electric Fuel Pumps

80 GPH at 45 psi, -10 AN inlet/outlet for EFI applicationsEDE1790\$576.95
120 GPH (free flow), 3/8" NPT inlet/outlet for carb applicationsEDE1791\$206.95
160 GPH (free flow), 1/2" NPT inlet/outlet for carb applicationsEDE1792\$208.95



Holley



500 cfm 2 BBL.

30cc GFLT Accelerator Pump Diaphragm System. HP metering block with non-adjustable metering.
HOL-80583-1...\$546.95

Truck Avenger Carbs

It is Designed Specifically for Off-Road Applications. The Unique Fuel Metering Block Eliminates Fuel Spillover through the Boosters at Extreme Angles Allowing for 40 Degree Climbing, 30 Degree Side Hill Maneuvers and Nose-Down Descents to Avoid Hesitations, Stalling and Flooding Typically Associated with Carbs in an Off Road Environment.
470 cfmHOL-90470\$572.95
670 cfmHOL-90670\$572.95
770 cfmHOL-90770\$540.95



Street Avenger Carbs

No Trouble Quick Change Adjustable Vacuum Secondary. 4th Generation No Trouble Power Valve. Built-In No Trouble Secondary Fuel Filters. Adjustable Needle and Seat. No Trouble Electric Choke. Four Vacuum Ports. Street Avenger Fuel Metering System.
570 cfmHOL-80570\$481.95
670 cfmHOL-80670\$481.95
770 cfmHOL-80770\$481.95
870 cfmHOL-80870\$481.95



Aluminum 4 Bbl Carb

Alum Construction which weighs only 7.85 lbs! Features a tumble polished finish - can also be hand polished. Vacuum Secondaries for use on a wide variety of vehicles. Quick Change Secondary spring cap lets you choose the opening rate of the secondary barrels. Four vacuum ports. Built-in inlet fuel filters. Fuel line kit included. Dual feed fuel inlet. 1 timed (spark) port, 2 full vacuum, & 1 PCV port. Ford A/T kickdown, doesn't work with A.O.D. trans.
670 cfm Electric ...HOL-83670...\$454.95
670 cfm Manual ...HOL-85670...\$442.95
770 cfm Electric ...HOL-83770...\$454.95
770 cfm Manual ...HOL-85770...\$442.95

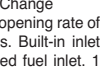

Double Pumper

Dichromate Finish. Manual Choke. Power Valve Blowout Protection. Dual Metering Blocks. Dual Feed Fuel Inlets. Model 4150 w/ Center Hung Floats. 100% Wet-Flow Tested & Calibrated. Mech Secondaries (Dual Accelerator Pumps).
600 cfmHOL-4776C.....\$544.95
650 cfmHOL-4777C.....\$544.95
700 cfmHOL-4778C.....\$578.95
750 cfmHOL-4779C.....\$578.95
800 cfmHOL-4780C.....\$614.95
850 cfmHOL-4781C.....\$614.95



4150 HP Carb

Contoured Venturi Inlet. High Flow Metering Blocks. 4 Corner Idle System. Center Hung Dominator Style Fuel Bowls. Spun-in Down Leg Boosters. Power Valve Blow-out Protection. 100% Wet Flow Tested and Calibrated.

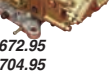

650 cfmHOL-80541-1.....\$672.95
750 cfmHOL-80528-1.....\$704.95
750 MethanolHOL-80535-1.....\$704.95
830 cfmHOL-80509-1.....\$729.95
950 cfmHOL-80496-1.....\$770.95
1000 cfmHOL-80514-1.....\$770.95

Carb Carrying Case

Made of durable plastic, it is designed to securely hold & protect your carb during storage or transportation. This case can hold a Holley model 2300 carb or any of the square flange 4 barrels.
Size: L 17.88". x W 11.75" x H 16.5"
HOL36-176\$75.21



500 cfm 2 BBL.

Model 2300. Manual Choke. 50cc Accelerator Pump. Center Hung Float Bowl.

Classic Finish..HOL-4412C...\$430.95



500 CFM Ultra XP 2BBL

All aluminum construction for nearly 50% weight savings over zinc version. Tumble polished alum w/Black billet alum metering block and base plate. No choke tower for unobstructed airflow. Air bleeds moved outward to allow a smoother transition of airflow. 5/16-18 bent air cleaner stud included. Down-leg boosters for improved fuel signal.
HOL-4412BKX...\$542.95



600 cfm 4 BBL.

Features: Vacuum Secondary. Electric Choke. Power Valve Blowout Protection. Model 4160 W/Side Hung Floats. Single Feed Fuel Inlet. Vacuum Ports: 2 Full Manifold, 1 Timed Vacuum. NEW "Next Gen" Needle and Seat Design Eliminates the Need for External Float Level Adjustment.
HOL-80457S.....\$341.95



Ultra XP Carburetors

Ultra XP carbs are 38% lighter than our original HP, have fuel capacity that is 20% greater and 30 other new features! They're available in our all-new Hard Core Gray hard coat anodized finish with Black billet for improved corrosion protection. Holley Ultra XP carbs offer new features such as an integrated idle bypass valve that allows for idle adjustments while maintaining the correct throttle plate to transfer slot relationship, high capacity fuel bowls which feature 20% more fuel capacity to eliminate starvation, integrated fuel shelf to minimize fuel aeration and internal baffling to control fuel slosh.

Alum. Ultra XP - Hard Core Gray

600 cfm ..HOL-80801HBX \$823.95
650 cfm ..HOL-80802HBX \$823.95
750 cfm ..HOL-80803HBX \$855.95
850 cfm ..HOL-80804HBX \$897.95
950 cfm ..HOL-80805HBX \$918.95
950 cfm ..HOL-80835HBX \$918.95



Methanol

Alum. Ultra XP - Shiny w/ Black Billet

600 cfm ..HOL-80801BKX \$769.95
650 cfm ..HOL-80802BKX \$769.95
750 cfm ..HOL-80803BKX \$800.95
850 cfm ..HOL-80804BKX \$833.95
950 cfm ..HOL-80805BKX \$865.95



Alum. Ultra XP - Shiny w/ Red Billet

600 cfm ..HOL-80801RDY \$769.95
650 cfm ..HOL-80802RDY \$769.95
750 cfm ..HOL-80803RDY \$800.95
850 cfm ..HOL-80804RDY \$833.95
950 cfm ..HOL-80805RDY \$865.95



Dominator HP Carb

They were designed specifically for making Top End Horsepower and Torque in High End Racing Engines. 3 Circuit Dominators add another Level of Transition thus Requiring Less Pump Shot.

1050 cfm ..HOL-8896-1...\$870.95
1150 cfm ..HOL-80556-1...\$949.95



Aluminum Air Pans

They fit between the carb and cowl area. Pan keeps engine heat away from the carb and allows cool fresh air from the cowl/windshield base area to enter the carb. Cooler intake air means extra hp. Carb mounting flange is uncut.
ALL26101\$82.99



Fuel Line Kits

Dual feed fuel line kits include the correct fittings and hoses to properly plumb single carburetor applications when connecting to AN style fitting. Line kits also include a capped -4AN fitting which can be easily connected to a fuel pressure gauge. Kits are offered with -6 or -8 lines and fittings.
ALL26166\$64.99



B-Nut Fuel Line Kits



Single Inlet

Ano-Tuff

SS Hose

4150/4150 HP Series
9.5"
-6 AN EARAT101185.....\$100.95
-8 AN EARAT101285.....\$115.95



Single Inlet

Ano-Tuff

Pro-Lite

350 Hose

4150/4150 HP Series
9.5"
-6 AN EARAT101195.....\$100.95
-8 AN EARAT101295.....\$115.95

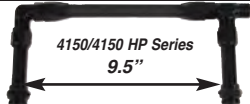

Dual Inlet

Ano-Tuff

Stainless

Steel Hose

4500 Series
12"
-6 AN EARAT102196.....\$112.95
-8 AN EARAT102296.....\$141.95

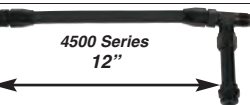

Billet Style

Fits 4150 series. Single Inlet Swivel Seal w/9-1/2" spacing. -8 AN male inlet. Single Inlet..EAR101275...\$114.95
Dual Inlet...EAR101276...\$138.95



Fits 4500 series. Single Inlet Swivel Seal w/ 12" spacing. -8 AN male inlet.
EAR102275\$118.95

Holley

Ano-Tuff

Carb Fuel Line

Single Inlet B-Nut

Disassembly Swivel Seal Pro Lite 350

-6 AN HOL34-42\$112.95

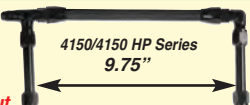

Ano-Tuff Fuel Line

Kit Single Inlet

B-Nut Disassembly

Swivel Seal

Pro Lite 350

-6 AN EARAT104195.....\$99.47
-8 AN EARAT104295.....\$114.95

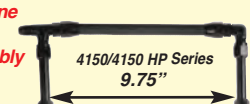

Ano-Tuff

Fuel Line Kit

Dual Inlet B-Nut

Disassembly

Swivel Seal Pro Lite 350

-8 AN EARAT104286.....\$140.95

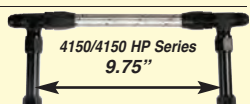

Vent Tube Spill Reduction Valves

The vent tube spill reduction valve reduces spillage from your Holley carb's vent tubes in the event of a carb or rough terrain experienced in racing. Reduces fuel spillage from vent tube in crash situations. Reduce fuel slosh from vent tube during hard launches/stops or rough terrain in racing.
HOL26-342...\$116.95



Fuel Log with

Dead Head Regulator

CVSPIN-MP-1000-4150.....\$339.95



Fuel Log w/Dead Head

Regulator for Ultra

CVSPIN-MP-1000-4150-ULTRA...\$352.42



Fuel Log with

Adjustable

By-Pass

Regulator

CVSPIN-MP-2000-4150.....\$270.95



Dual Action

Adjustable

Fuel Log

For 4150 or 4500 Dominator Style Float Bowls. Carburetor inlets swivel + or - 20° in all directions. Telescoping center line 7.700" to 13.450". ORB-10 inlet and outlet ports. (2) 1/8" NPT ports for gauges or pressure transducers. 1.056 / .806" ID bore. Type II bright dip black anodized finish.
AER14201\$325.56



Alum Double Pumper

They are constructed from aluminum which compared to their zinc counterpart offer a 38% weight savings. Improved Fuel bowl design. Vibratory polished aluminum for good looks, weight savings and long lasting shine. Optimized street/strip calibration that works out-of-the-box. Manual choke for precise cold start control. Mech secondaries for awesome tire turning perf. 4 corner idle allows you to precisely control your idle system. Dual accelerator pumps for additional fuel under initial acceleration.

600 cfm	HOL-4776SA	\$475.95
650 cfm	HOL-4777SA	\$475.95
700 cfm	HOL-4778SA	\$519.95
750 cfm	HOL-4779SA	\$506.95
850 cfm	HOL-4781SA	\$538.95



4150 Alum Ultra XP Circle Track Series

Calibrated specifically for use on circle track. Has a set screw in the base plate for wide open throttle stop adjustment. PTFE coated throttle shafts rides in oil impregnated bronze bushings for smooth throttle actuation. Anti-siphon valve in main body to reduce pump pullover. Contoured venturi inlet offers balanced airflow for increased horsepower. Dual 30cc accelerator pumps provide the perfect amount of fuel from idle to full throttle. Knurled (hand adjustable) primary & secondary curb idle screws allow for easy idle adjustment w/o the use of tools.

650 cfm.....	HOL-80812BKX	\$769.95
650 cfm Hard Black.....	HOL-80812HBX	\$823.95
750 cfm.....	HOL-80813BKX	\$796.95
750 cfm Hard Black.....	HOL-80813HBX	\$855.95



Brawler Race 4150 Carb

These carbs work hard just as their name implies- just raw bare knuckled performance that you can rely on. The second phase of new carburetors build on the success of the originals by adding more cfm sizes and options including a black coated finish. Brawlers come with the latest tech in air/fuel calibrations for today's street or race engine demands. The Brawler family of carbs are all made from light-weight alum components and are available in both vacuum and mech secondary models.



Mechanical Secondary 4150

650 CFM Black.....	QUIBR-67301	\$525.95
750 CFM Black.....	QUIBR-67302	\$530.95
850 CFM Black.....	QUIBR-67303	\$600.95
950 CFM Black.....	QUIBR-67304	\$619.95
650 CFM Silver.....	QUIBR-67199	\$497.95
750 CFM Silver.....	QUIBR-67200	\$501.95
850 CFM Silver.....	QUIBR-67201	\$514.95
950 CFM Silver.....	QUIBR-67202	\$546.95
1050 CFM Silver.....	QUIBR-67209	\$661.95
750 CFM Silver Circle Track.....	QUIBR-67215	\$539.95

Vacuum Secondary 4150

650 CFM Silver Vacuum.....	QUIBR-67204	\$495.95
750 CFM Silver Vacuum.....	QUIBR-67205	\$500.95



Carb Fittings Fuel Filters

It uses a 60 micron stainless filter in the fitting. Filter is removable for cleaning & the 7/8"-20 thread fits Holley carbs.

-8 AN B-Nut Filter-Fitting	PET09-0701	\$39.38
-8 Nose Filter Fitting	PET09-0702	\$36.52
-8 AN B-Nut Filter-Fitting Long	PET09-0711	\$41.35
-8 Nose Filter Fitting Long	PET09-0712	\$41.35

Aluminum Carb Fittings

Blue anodized, extra long fittings are commonly used with fuel logs. Overall length is 3.5" which spaces fitting 3" from carb. Sold individually.

7/8-20 to -8.....	ALL50900	\$16.99
9/16-24 to -8.....	ALL50901	\$16.99

Dual Feed Holley

Adapter Size 7/8-20 hose end -8
EAR991948

Rochester

Adapter Size 7/8-20 hose end -6
EAR991949

Single Inlet Holley

Adapter Size 9/16-24 hose end -6
EAR991942

Dual Feed Holley

Adapter Size 7/8-20 hose end -6
EAR991943

-8 AN Male to 7/8"-20 Male

Blue Anodized LW Alum Construction. Typical Application/Holley/Reman Dual Feed Carb.
EAR991957



650 cfm Thunder Series AVS Carbs

Exciting performance features that include the Qwik-Tune Adjustable Secondary Air Valve and dual fuel inlet. Distinctive black accented hardware. Lightweight ball-burnished aluminum that's CNC-profiled on front face for an attractive finish. Electric Choke or Manual Choke.

Manual.....	EDE1805	\$374.95
Electric.....	EDE1806	\$423.95

600 cfm Performer 4 BBL.

Street Legal, Electric Choke, Calibrated For Fuel Economy. It includes timed vacuum ports, EGR and fuel vapor outlet. Comes with the following jets, rods and springs: Metering Jets - Primary .098, Secondary .095; Metering Rods - .073 x .047; Step-Up Spring - orange (5" Hg). Includes carb studs and hardware.

EDE1400	\$398.05
---------------	-----------------



750 cfm Performer Series 4 BBL. w/Electric Choke

Comes with Metering Jets - Primary .110, Secondary .107; Metering Rods - .075 x .047; Step-Up Spring - orange (5" Hg.) Use our carb stud kits EDE8008 or EDE8024 if needed.

EDE1411	\$393.95
---------------	-----------------



600 cfm Performer 4 BBL.

Square flange. Includes vacuum ports for ignition advance as well as a timed vacuum port. Supplied with complete installation kit, including wiring and terminals for electric choke.

Manual Choke..	EDE1405	\$319.95
Electric Choke..	EDE1406	\$349.95

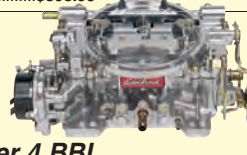

Carb Maintenance Kits

Float Kit (2 floats, 2 pins & a float setting gauge)
EDE1469

EDE1469	\$15.29
---------------	----------------

Accelerator Pump Assembly for 1400, 1403, 1404, 1405, 1406, 1805, 1806, 1825, & 1826
EDE1470

EDE1470	\$13.25
---------------	----------------

Accelerator Pump Assembly for 1407 and 1411

EDE1467	\$13.35
---------------	----------------

Accelerator Pump Assembly for 1412, 1413, 1812, and 1813.....

EDE1468	\$13.39
---------------	----------------

Marine Accelerator Pump (includes seal, spring and cup assembly for 1409/1410)

EDE1471	\$29.85
---------------	----------------

Gasket Kit (includes airhorn and carb-to-manifold gasket).....

EDE1472	\$13.35
---------------	----------------

Performer Series Linkage Kit (includes 1 each of 7 links and 6 retaining clips)

EDE1473	\$15.95
---------------	----------------

AVS Carb Linkage Kit (includes 1 each of 7 links and 6 retaining clips)

EDE1873	\$17.95
---------------	----------------

Carburetor Rebuild Kit (includes parts & gaskets to rebuild all Edelbrock square bore carbs).....

EDE1477	\$40.85
---------------	----------------

Replacement Fuel Inlet Fitting (5/8"-20, 3/8" nipple, gold iridited).....

EDE1497	\$15.45
---------------	----------------

Replacement Needles and Seats (.0935" diameter, pair).....

EDE1498	\$16.45
---------------	----------------

Airhorn Gasket (5 gaskets).....

EDE1499	\$16.49
---------------	----------------

Carburetor Base Gaskets (2 gaskets).....

EDE3899	\$10.17
---------------	----------------



Dual-Feed Fuel Line & Filter Kits For All Thunder Series AVS Carbs

Dual-Feed Fuel Line with blue anodized aluminum filter (replacement filter only EDE8130)

EDE8133	\$94.95
---------------	----------------

Dual-Feed Fuel Line with polished aluminum filter (replacement filter only EDE8129)

EDE8128	\$84.95
---------------	----------------

Chromed Steel Dual-Feed Fuel Line with no fuel filter and 3/8" barbed end inlet

EDE8132	\$81.95
---------------	----------------

Holley Gasket

For Center Hung Float Bowls. 2 Per Pkg.
HOL108-8.....

HOL108-8.....	\$7.00
---------------	---------------

Gasket

Fuel Bowl Inlet Fitting for All Holley Carbs w/Center Hung Floats. 7/8" Nylon. 2 Per Pkg.

HOL26-102	\$3.85
-----------------	---------------

Fits Ultra HP Series and uses EAR991958 for -8 Fuel Logs

Carburetor, Power Steering, Fuel Pumps, Fuel Injection

-8 AN Male to 3/4"-16 Male	EARAT991958	\$10.48
----------------------------	-------------------	----------------

-6 AN Male to 3/4"-16 Male

EARAT991959	\$9.72
-------------------	---------------

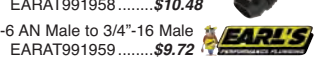

Holley Carb Adapter

-08 Female x 7/8"-20 - Black
GOOHOLCAB-08DBW...**\$26.32**

Alum Crush Washer

GOOCW901-10

GOOCW901-10	\$0.53
-------------------	---------------

O-Ring Carb Nuts

Seal air cleaner and eliminate using a wrench to remove air cleaner assembly. Available in 1/4" and 5/16" thread.

Short, 1/4" Thread.....	ALL26045	\$10.99
-------------------------	----------------	----------------

Tall, 1/4" Thread.....	ALL26046	\$11.99
------------------------	----------------	----------------

Short, 5/16" Thread.....	ALL26047	\$10.99
--------------------------	----------------	----------------

Tall, 5/16" Thread.....	ALL26048	\$11.99
-------------------------	----------------	----------------

Fuel Log

Designed to fit Holley 4777 and Holley HP Carbs. 1.5" outer dia X 16" long. Complete with all necessary fittings. Has AN 4 outlet for fuel pressure gauge or regulator. 3/8" Pipe thread inlet (kit comes with 3/8" pipe to AN 8 adaptor). Kit also comes with alum carb fittings & gaskets.

BRP5044	\$115.62
---------------	-----------------

Fuel Directors

Designed for Holley carbs, these are the lightest fuel logs on the market. Unique sliding nut assembly for quick disassembly is only 1 of the special features. -8 AN inlets, 3/4" line port and 1/8" fuel pressure port. Must Holley fittings.

Holley Single	KLUKRC-4408.....	\$96.84
---------------------	------------------	----------------

Holley Fittings (pair)	KLUKRC-4419.....	\$18.43
------------------------------	------------------	----------------

Demon Dual	KLUKRC-4428BK.....	\$132.97
------------------	--------------------	-----------------

Quick Kits

Holley's deluxe rebuild kits. Include gaskets, power valves, diaphragms, needle/seat and all kinds of goodies.

4160 Vacuum Secondary.....	HOL37-1542\$30.96
2300 Two Barrel.....	HOL37-1543\$29.86
4150 Double Pumper.....	HOL37-1544\$43.16
4150 HP Double Pump Vacuum Secondary.....	HOL37-1546\$56.46
4500 Dominator and Dominator HP.....	HOL37-1547\$67.55
Ultra Series Kit E85 4 BBL.....	HOL37-1549\$57.57
Ultra Series Kit 2 BBL.....	HOL37-1550\$33.20

Holley



Blue Non-Stick Holley Metering Block Gasket

For most Model 4150's, some 4160's, early 4165's and most 2300's. Secondary metering block gasket on double pumpers. Not used with accelerator pump transfer tube. Used on 4500's without intermediate idle system. Available in 2/pkg or bulk orders of 100 or more.

HOL108-89-2.....\$10.56

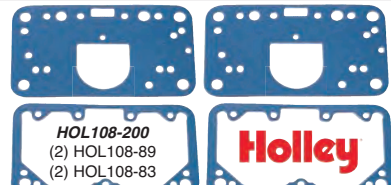

Metering Block/Fuel Bowl Gasket Pack

These gasket assortment have been selected to cover popular Holley 4 brl. Each contains the quantities of gaskets shown.

HOL108-200.....\$12.89

Blue Non-Stick Fuel Bowl Gasket

Model 2300, 4150/60 and 4500 two circuit carbs. Available in 2/pkg. or bulk orders of 100 or more.

HOL108-83-2.....\$10.56



Throttle Body Gasket

for Models 4150/4160 Carburetor (Single)

- A.) 1-7/16" x 1-7/16"
HOL108-61.....\$8.50
- B.) 1-9/16" x 1-9/16"
HOL108-3.....\$5.19
- C.) 1-11/16" x 1-11/16"
HOL108-5.....\$4.87
- D.) 1-3/4" x 1-3/4"
HOL108-7.....\$4.87

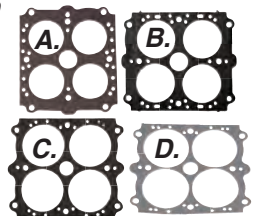

50cc Accelerator Pump Conversion Kit

Eliminate flat spot off idle or at any other rpm range. Includes new pump housing, arm diaphragm, spring and longer pump housing screws.

HOL20-11.....\$55.35

Accelerator Pump Cam Assortment Kit

Tailor Accelerator Pump Performance. Each Cam Is Different Shape/Profile. Gives Different Results.

HOL20-12.....\$28.75

Standard Main Jets

These metering orifices control fuel flow into the metering system. They are rated in flow capacity "cubic cms per minute" and are changeable for tuning purposes. The shape of the entry, exit, and size determines flow. All Holley Main Jets are flow tested & then stamped with the correct #. Std Main Jet, 1/4-32 Thread, .128" Jet size

- NOT FOR CARBS ORIGINALLY DESIGNED FOR ALCOHOL
- Fits All Model 2010, 2300, 4010, 4011, 4150, 4160 & 4500
- We now carry official Holley Jets in sizes from #44 to #94.

HOL122-(.....)\$7.93

Jet Extensions

Brass Jet Extensions screw into the metering block to reposition jets farther back into the fuel bowl to eliminate fuel starvation - and they won't fall out! Two per pack.

1/4"-32, Std Holley Jets.....MOR65440.....\$14.69
5/16"-32, HP Holley Jets.....MOR65441.....\$15.85

Carb Throttle Ball Assortment

For use on Holley universal carbs. Kit contains 4 Different Throttle Balls and Hardware.

HOL20-2.....\$14.07

Carburetor Throttle Secondary Adjusting Lever Kit

Secondary Throttle Adjusting Lever Kit. Allows quick and easy adjustment.

HOL26-137.....\$46.49

Carb Throttle Cable Bracket

Chrome throttle cable bkt & throttle return spring install. Includes dual stainless steel throttle return springs (HOL20-89). Works on Holley models 4150 & 4160 carbs.

HOL20-88.....\$28.74

Carburetor Throttle Stud

Throttle & Cruise Control Stud for Chrysler Apps

HOL20-67.....\$26.56

Holley

Single-Stage Power Valves

Standard Flow

2.5" Hg.....	HOL125-25.....	\$10.48
3.5" Hg.....	HOL125-35.....	\$10.48
4.5" Hg.....	HOL125-45.....	\$10.48
5.0" Hg.....	HOL125-50.....	\$10.48
5.5" Hg.....	HOL125-55.....	\$10.48
6.5" Hg.....	HOL125-65.....	\$10.48
7.5" Hg.....	HOL125-75.....	\$10.48
8.5" Hg.....	HOL125-85.....	\$10.48
9.5" Hg.....	HOL125-95.....	\$10.48
10.5" Hg.....	HOL125-105.....	\$10.48

High Flow

2.5" Hg.....	HOL125-125.....	\$16.26
3.5" Hg.....	HOL125-135.....	\$16.26
4.5" Hg.....	HOL125-145.....	\$16.26
5.5" Hg.....	HOL125-155.....	\$16.26
6.5" Hg.....	HOL125-165.....	\$16.26
8.5" Hg.....	HOL125-185.....	\$16.26
10.5" Hg.....	HOL125-1005.....	\$16.26

Viton Inlet Needles

Most Holley perf carbs come equipped with a Viton-tipped needle. The design is resistant to dirt and conforms nicely to the shape of the seat for superior sealing. For this reason it is not recommended to use a steel/titanium needle, except for racing.

Seat Size (Adj)

.097".....	HOL6-506.....	\$15.11
.110".....	HOL6-504.....	\$16.26
.120".....	HOL6-518-2.....	\$27.64

Throttle Linkage

Bracket Ford Trans Kickdown Extension

This handy part is used to extend the Ford O.E. trans kickdown lever when converting from a 2 bbl. to 4 bbl. carb. Ford O.E. Trans Kickdown Lever Extension.

HOL20-41.....\$7.02

Transmission Kickdown Stud

Effective Mounting Point. For Carb Hookup.

HOL20-40.....\$8.19

Hard Core Gray Alum V-Bowl Kits

The bowls are offered in both the classic style V-bowl, as well as the new Ultra Series style (which require a 0.250" longer fuel line). All kits include gaskets and bowl screws.

Primary Alum V Bowl Kit.....	HOL134-71HB.....	\$60.89
Secondary Alum V Bowl w/o Pump Kit.....	HOL134-72HB.....	\$55.35
Secondary Alum V Bowl w/ Pump Kit.....	HOL134-73HB.....	\$60.89
Ultra Series V Bowl Kit.....	HOL134-78HB.....	\$75.32

50cc Alum Accelerator Pump Kits

Holley 50cc accelerator pump kits are now available in aluminum with different finish and hardware options. Kits come with all necessary hardware to upgrade from a 30cc to a 50cc pump.

w/Black Hardware ..	HOL20-11BK.....	\$55.35
w/Gold Hardware ..	HOL20-11SA.....	\$55.35
w/Gray Hardware ..	HOL20-11HB.....	\$58.68

Oval Track Float Kit for Holley Carbs

Includes one front and one rear float. Fits all Holley center hung float/cathedral bowl carbs. Intended primarily for oval track racing, kit can also be used in drag race apps where two Holley Carbs are mounted sideways on manifold.

MOR65432.....\$30.44

Alum Fuel Block Kits

Universal, high flow Fuel Block Kits easily solve dual gas line problems assuring equal flow and pressure for twin carb setups or dual pickup gas tanks.

Alum Fuel Block Kit, 1/2" hose inlet with two 3/8" hose outlets.....MOR65160...\$31.52

Throttle Stop for Holley Carbs

For 4150-Series Carbs. It prevents excessive side loading on the throttle shaft, which can easily cause the throttle shaft bows to wear out. Made from rugged 1/8" steel with a clear zinc finish. Fits both 1:1 and progressive throttle linkages.

MOR65042.....\$29.51

Nylon Float Bowl Washer Kit

The ultimate cure for the problem of soft, wet, deteriorating fiber, Holley float bowl washers. 10 per pkg.

MOR65225.....\$7.11

Nylon Fuel Bowl Screw Gasket

Fits All Holley Carbs. Reusable Nylon. 10 Pk

HOL108-98-10.....\$10.56

Carburetor Air Pan Kits

All Air Pans measure 12" x 24". Fire retardant foam measures 1-1/2" wide x 4" tall x 60" long.

Dual 4-bbl. Holley Carbs

Holley carbs w/ 5-1/8" neck.....MOR65950.....\$73.49

Holley 4500 Dom. carbs w/ 7-5/16" neck.....MOR65951.....\$72.77

Single 4-bbl. Holley Carbs

Holley carbs w/ 5-1/8" neck.....MOR65960.....\$71.04

Holley 4500 Dom. carbs w/ 7-5/16" neck.....MOR65961.....\$71.04

Replacement Parts Sealing Foam, 4" x 60".....MOR97070.....\$16.16

Pro Series Secondary Linkage

Stainless Steel construction and a lightweight yet rugged design, it provides a bulletproof method of adjusting secondaries on All Double Pumper, HP, and Ultra HP carbs. It allows user to pick between 1:1 or progressive secondary ratio. Kit provides infinite adjustment of secondary throttle blades for max hp output. Pro-Series Adj Secondary Linkage Kit for Holley Double Pumper and HP series Carbs.

HOL20-122.....\$36.52

Diaphragms w/o screws

HOL135-5.....	30cc (rubber).....	\$3.46
HOL135-7.....	50cc (rubber).....	\$17.44
HOL135-9.....	50cc (GFLT).....	\$17.44

*GFLT Diaphragms are compatible for use with all alcohol base fuels.

Holley





Angled Carburetor Spacer



For dirt late models and modifieds spacer is angled downward, toward left front, to correct hesitation caused by poor fuel distribution as car "rocks up". 4-hole design enhances carb signal to improve throttle response and increase torque. ALL25975...\$234.99



2" Tapered Spacer Kit

They feature the J-Form threads to resist loosening & vibration. All carb stud kits come with hex nuts & washers. Qty 4: 5/16" x 1.250" Qty 4: 5/16" x 1.700" ARP200-2409...\$31.19



Carb Base Gaskets for Holleys



4150/4777 Open Plenum.....FEL1900...\$5.23
4150/4777 4-hole 1 3/4".....FEL1901...\$5.31
Dominator 4500 Open Plenum..FEL1903...\$5.32
4412 2-bbl 1 3/4".....FEL1904...\$4.69



Air Filter Gaskets

Holley, Carter, Q-Jet.....FEL2104...\$8.68
Dominator 4500.....FEL2105...\$9.83



Carburetor Stand



Alum stand simplifies carb maintenance and will hold carb off of work bench surface. Works with Edelbrock, Quadrajet, and Holley 2- and 4-barrel carbs. ALL26200...\$52.99

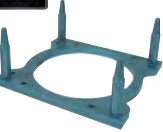

Carb Work Stand

Designed to hold Quadrajet and both std and spread-bore Holley carbs, this tool greatly simplifies carb work. Manufactured of cast alum w/open center & mounting pegs. MOR62070...\$24.20



Carb Top Tool Trays

Made from LW, durable, .063" alum for Holley 5-1/8" Dominator carbs. Also fits other carbs with similar neck diameters. Each Tool Tray sits just 2-1/2" above the carb and features a convenient handle, 1/8" rubber mat, 16 spark plug holders, 8 plug wire holders and enough room to store a variety of tools for working on just about any engine. Inside tray size: 10" x 13". MOR65801...\$116.05



Stub Stacks



Reduce turbulence and restriction, improve metering accuracy and airflow by up to 40 cfm!

Holley carb

4412/6425 2bbl.K&N85-0210\$48.99
4150/4160 w/choke.....K&N85-0200\$47.99
4150/4160 w/o choke, uses air filter.....K&N85-0400\$28.99
4150/4160 w/o choke, no air filter.....K&N85-0500\$36.99
1050/1150 Dominator, no air filter.....K&N85-0600\$49.99



Carb Spacer 1/4" Thick, Billet Aluminum

BRP9092...\$27.84

Aluminum 2 bbl. Adapter

Adapts Holley 4412 2bbl. to 4bbl. manifold. 1.700" bores. DIRT Approved. BRP377...\$55.29

Adj 2 bbl. Adapter

Adapts Holley 4412 2bbl. to 4bbl. manifold. Radiuses on the bottom of the bores for smoother flow. Slotted mounting holes so you can slide it forward & backward on the manifold to find hp. BRP376...\$112.16



Carb Float Bowl Kits

They're made from 304 stainless steel & are virtually impervious to corrosion. A polished finish makes them an enhancement to any carb. They are 5/16" wrenching and nominally rated at 170,000 psi. Available for both single and dual metering block apps.

2-barrel, hex.....4 Qty.....ARP400-0312.....\$14.20
Dual metering blocks, hex.....8 Qty.....ARP400-0310.....\$26.85
Single metering blocks, hex.....8 Qty.....ARP400-0311.....\$26.53

Carburetor Stud Kits

The best way to make carbs stay perfectly sealed to the intake manifold is through the use of ARP's carb studs, which feature J-form threads to resist loosening from vibration.

Quantity: 4 - Size: 5/16

Applications.....O.A.L.....Black Oxide
Standard.....1.700.....ARP200-2401 \$17.35
1" spacer.....2.700.....ARP200-2402 \$17.96
2" spacer.....3.700.....ARP200-2404 \$18.89
3" spacer.....4.700.....ARP200-2405 \$19.43
1-1/4" Moroso spacer.....3.200.....ARP200-2408 \$18.72
2" Moroso spacer.....1.250 & 1.700.....ARP200-2409 \$31.19
Dominator carb stud, w/spacer.....4.400.....ARP200-2415 \$19.06
Std w/MOR64919 Return Spr. 1.700 & 2.050.....ARP200-2421 \$15.93
Std w/MOR64927 Return Spr. 1.700 & 2.050.....ARP200-2424 \$15.88
1" sp MOR64919 Return Spr. 2.700 & 3.050.....ARP200-2420 \$17.61
1" sp MOR64927 Return Spr. 2.700 & 3.050.....ARP200-2423 \$17.53
2" sp MOR64919 Ret Spr. 1.250&1.700&2.050ARP200-2419 \$30.49
2" sp MOR64927 Ret Spr. 1.250&1.700&2.050ARP200-2422 \$30.44
Applications.....O.A.L.....Stainless 300
Standard.....1.700.....ARP400-2401 \$24.01
1" spacer.....2.700.....ARP400-2402 \$22.81
1-1/4" Moroso spacer.....3.200.....ARP400-2408 \$23.54



Alum Carb Cover Assy



Quickly and efficiently covers carb with a water and vibration proof, speed nut design. Speed nut locks onto cover with "O-Ring" seal assembly - no misplaced nuts.

1/4-20 Speed Nut & Carburetor Cover KLUKRC-1029...\$21.80

5/16-18 Speed Nut & Carburetor Cover KLUKRC-1030...\$21.80

5-1/8" Carburetor Cover Only KLUKRC-1031...\$11.52

Speed Nut Assembly Kit

1/4-20 Speed Nut KLUKRC-1033...\$16.45

5/16-18 Speed Nut KLUKRC-1034...\$16.45



MOROSO Carb Tops

Keeps dust and other foreign transportation and storage. Manufactured from durable, high-impact plastic. Thumbscrew included 5-1/8" fits.

4150/4160 and Q-Jet..MOR65802..\$8.45
7-5/16" fits 4500 Dom.MOR65803..\$13.74

Carb Hats w/Screen

For use in garage or pit area when air cleaner needs to be removed. Screen type hat recommended when adjusting valves. ALL26042..\$15.99



Aluminum Carb Hats

Great for garage or pit area when air cleaner is removed. 2-1/2" tall for use with 5-1/8" dia carb necks. Std hat is spun, deluxe is machined and has a sealing O-ring. Standard.....ALL26043...\$15.69
Deluxe.....ALL26044...\$21.99



Holley Jet Assortment Kit

Holley 2-bbl and 4-bbl Perf. Carbs This kit consists of (2) each of (36) different jet sizes, ranging from #64 to #99. HOL36-181...\$63.13



Inline Street Filter



Color 5/16".....3/8"
Blue PRF10200.....PRF10203
Red PRF10201.....PRF10204
Alum PRF10202.....PRF10205...\$11.18
Replacement Element.....PRF10220...\$3.11



Inline Performance Filter

Adapter fittings are available that will allow it to work with 1/4", 5/16" or 3/8" hose as well as -6 and -8 AN lines. This filter will flow up to 160 GPH @ 7PSI and will filter down to 10 microns.



Red/Blue Filter.....PRF10210...\$22.37
Replacement Element.....PRF10221...\$4.97

Hi-Tech Fuel Filter

This filter will flow up to 150 GPH at 7 PSI and filters to as fine as 10 microns.



Red/Blue Filter.....PRF10214...\$39.75
Replacement Element...PRF10222...\$10.61



Carburetor Spacers

Open plenum alum carb spacers increase plenum volume for high RPM power. 4 hole carb spacers increase mixture velocity for more midrange torque. Not legal for sale or use on pollution-controlled vehicles.

1" Spacer. Fits Holley 4500 Dominator bolt pattern open plenum design billet alum.....MOR64950 \$43.98
1" Spacer. Fits Holley 4500 Dominator bolt pattern open plenum design cast alum.....MOR64951 \$63.00
2" Spacer. Fits Holley 4150/4160 bolt pattern, open plenum design.....MOR64970 \$63.13
1/2" Spacer. Fits Holley 4150/4160 bolt pattern, open plenum design billet alum.....MOR64985 \$47.31
1" Spacer. Fits Holley 4150/4160 bolt pattern, open plenum design.....MOR64980 \$51.98



Insulating Plastic and Phenolic Carburetor Spacers

Advanced plastic and phenolic compounds are specially formulated to reduce heat conductivity 10 times greater than alum. Reducing fuel temp inside the carburetor results in a denser, more powerful fuel charge to the manifold. Gaskets not included. Not legal for sale or use on pollution-controlled vehicles.

1" Spacer. Fits Holley 4150/4160 bolt pattern, 4-hole plenum design w/1.75" dia. bores.....MOR64930 \$36.91
1" Spacer. Fits Holley 4150/4160 bolt pattern, open plenum design.....MOR64940 \$37.19
1/2" Spacer. Fits Holley 4150/4160 bolt pattern, 4-hole plenum design w/1.75" dia. bores.....MOR64943 \$39.43
1/2". Fits Holley 4500 Dominator bolt pattern, open plenum design.....MOR64947 \$32.99
1/2". Fits Holley standard carbs, single hole wood design.....MOR65015 \$33.16

Fuel Pumps

700 HP EFI Fuel Pump

- Up to 700 HP naturally aspirated
- Up to 500 HP forced induction (Requires Bypass Regulator AER13105)

For fuel injected applications with base pressure settings between 30 and 65 PSI. Designed to fuel anything from 150 to 700 hp naturally aspirated, up to 500 hp forced induction. Flows over 450 lbs. per hour @ 13.5 Volts and 45 PSI. -8AN inlet and -6AN ports. Compact size facilitates easy mounting. Fully submersible for custom, in-tank placement. Pumping mechanism features our proprietary composite material, 304 stainless steel roller vanes, and 6061-T651 aircraft-grade aluminum alloy plates. Plates are coated with protective finishes per Military Specification MIL-A-8625 type III hardcoat anodize. The body and end-caps of the pump also utilize 6061-T651 aircraft grade alum and are finished with a type II bright dip anodize

StandardAER11106\$391.39
Tsunami.....AER11103\$389.04

A1000 In-Line Fuel Pump

ORB-10 inlet and outlet ports. For EFI applications use regulator P/N 13101 or P/N 13109. For carb applications use regulator P/N 13204. Fully submersible for custom, in-tank placement. Perfect for "blow-through" carbureted engines up to 1200 HP. Billet Speed Pump Controller (AER16306) recommended for EFI street applications.

Fuel Injected: up to 1300 HP - naturally aspirated • up to 1000 HP - forced air induction
Carb Engines: up to 1500 HP - naturally aspirated • up to 1200 HP - forced air induction
AER11101...\$411.99

Eliminator Fuel Pump

This continuous duty "street warrior" supports big hp and maintains the drivability necessary for a true high performance street car. Designed for high hp street/strip applications, EFI or Carb, it features our "dual chamber" pumping mechanism. ORB-12 inlet port and ORB-10 outlet port. For EFI applications use regulator AER13110, carb AER13212. Fully submersible for custom, in-tank placement. 25% more flow at pressure than our A1000 Fuel Pump. Perfect for "blow-through" carb engines up to 1700 HP. Billet Speed Pump Controller (AER16306) required for EFI street applications.

Fuel Injected: Up to 1900 HP - naturally aspirated • Up to 1400 HP - forced air induction
Carb Engines: Up to 2300 HP - naturally aspirated • Up to 1700 HP - forced air induction
AER11104\$607.69

Pro Series Fuel Pump

Engineered for high-horsepower racing engines, this beautiful pump features a "dual chamber" pump design.

- ORB-12 inlet and outlet ports.
- Beautifully plated with our electroless nickel process.
- Two ORB-12 / AN-12 Male adapter fittings included.
- For EFI use regulator AER13110, carb AER13202 or AER13212
- Perfect for "blow-through" carb engines up to 2000 HP.

Fuel Injected: Up to 2200 HP - naturally aspirated • Up to 1700 HP - forced air induction
Carb Engines: Up to 2600 HP - naturally aspirated • Up to 2000 HP - forced air induction
AER11102\$823.99

Billet Hex Drive Fuel Pump

Utilizes standard, 3/8" hex drive shaft and adjustable, billet mounting collar with standard 3-bolt mounting pattern and hardware. Proven performance, powering some of the world's fastest EFI vehicles. Supports up to 3600 HP gas, 1800 HP methanol. Compact size facilitates easy mounting. Billet aluminum CNC-machined body, not "cast". ORB-10 inlet and outlet ports. For EFI applications use regulator AER13113. Carbureted gasoline apps require regulator AER13202 or AER13212. Alcohol applications require Double Adjustable Regulator AER13209 or AER13214. Note: Electric Priming Kit available - AER17301 (see Accessories)
AER11107\$739.62

Street Rod Fuel Pump

- Up to 700 HP (Requires AER13201/AER13205 Regulator or AER13301 Bypass Regulator)

For carbureted powerplants making 200-750 HP w/standard regulators and up to 1,000 HP with dynamic, bypass style regulators. Ideal for continuous duty, carburetor applications where more line pressure, flow volume and reliability are desired.....AER11203.....\$221.70

T-Style High Output (H/O) Billet Fuel Pump

- Up to 500 HP (Regulator Not Required)

Flow volume exceeds 550 lb/hr or 90 GPH at 5 PSI. Internally regulated to 7 PSI, the H/O pump should not require a separate regulator on most carburetors. Rated for continuous duty, the pumping mechanism has all the same features of it's older brother including composite rotor, stainless steel vanes and heat treated steel top and bottom plates for durability. 3/8" NPT inlet and outlet ports for use with common AN or other adapter fittings. Draws less than 5 amps.....AER11209.....\$227.79

A2000 Drag Race Fuel Pump

- Up to 2500 HP (Drag Race Only)

(Requires AER13203 Reg or AER13202 Bypass Regulator)

500-2500 HP on gasoline, and up to 1500 HP on alcohol. High torque, low rpm motor design delivers more than 350 GPH free flow, while developing less current draw than any other pump in it's class. Adj. diaphragm bypass valve outperforms ineffective poppet designs, minimizing common flow loss & pressure fluctuation into the regulator at the carb. -10 AN inlet and outlet ports with a -8 AN return port & 1/8" NPT gauge port. Proprietary seal design eliminates leakage...AER11202...\$486.92

Compact size facilitates easy mounting

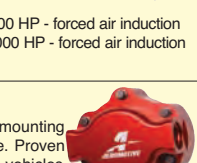
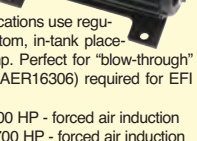
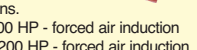

Regulators

A1000 Injected Bypass Regulator

For 1000 HP applications that require flexibility. Intended for use with custom fuel rails, this true billet regulator was designed specifically for use with our A1000 Fuel Pump. Base pressure (vacuum/boost disconnected) adjustable from 30 to 70 PSI. Two -10 AN inlet ports, one -6 AN return port and 1/8" NPT gauge port. Beautifully finished with type II bright dip red and black anodized coatings. Alcohol compatible. Fuel Pressure will rise on a 1:1 ratio when referencing boost. Fittings Sold Separately.
AER13101...\$185.39

Compact EFI Regulator

For applications producing up to 1,000 HP where space is at a premium. Compact design fits small engine compartments while providing big performance, flows enough to handle 1,000 HP fuel pumps. Ideal for EFI systems where only one inlet is needed. Adj from 30 to 70 PSI. New design, equipped with removable -6 AN male fittings for inlet and outlet ports- eliminates the need to buy additional fittings and O-rings. Dedicated, 1/8" NPT gauge port located opposite the side inlet. Vacuum/boost port relocated to the side of the cap for easier pressure adjustments. Fuel pressure will rise on a 1:1 ratio when referencing boost. Bright zinc-plated steel bracket.
AER13105...\$235.87

Universal Bypass Regulator

Dual purpose, universal regulator for carbureted or EFI fuel systems in street or track applications. Base pressure adjustable from 3 to 20 PSI with standard spring (installed) or 20 to 60 PSI with high pressure spring (included). Ideal for carbureted and EFI bypass applications where more flow and superior pressure control are desired.
AER13301.....\$160.55

Pro-Series Boost Reference EFI Regulator

For high horsepower EFI applications - the only regulator that can deliver enough flow to support 2000 HP. If your EFI Engine requires high volume, high pressure fuel delivery, you need the Pro-Series Boost Reference EFI Regulator. Recommended for use with Aeromotive Eliminator Fuel Pump and Pro-Series Fuel Pump.
AER13110...\$327.66

Belt / Hex Drive EFI Regulator

Ultra-High Flow EFI Regulator, adjustable from 40-100 PSI. Engineered for our Belt-Drive and Hex-Drive Fuel Pumps, the Belt Drive EFI Regulator is suitable for engines making up to 4,000 HP on gasoline and is compatible with gasoline and methanol. Perfect for any mechanically driven EFI fuel pump developing over 200 GPH at EFI pressure. Base pressure adjustable from 40-100 PSI. References Vacuum/Boost on a 1:1 ratio. Includes two boost line adapters, one barbed for rubber hose, the other for AN-04 braided line. (Prevents blow-off in high boost applications) Ports available for nitrous fuel supply, pressure gauges and transducers. (4) ORB-08 inlet ports, (1) ORB-10 inlet port and (1) ORB-10 return port.
AER13113...\$272.99

Carbureted Adj Regulator

Regulator re-seats after the needle shuts down, reducing pressure creep. -6AN female inlet & outlet ports on AER13201. 3/8" NPT inlet & outlet ports on AER13205. 1/8" NPT gauge port. Adjustable from 5-12 PSI.

-6AN Port.....AER13201...\$106.06 Fittings sold separately
3/8" NPT Port.....AER13205...\$115.99

A2000 Carbureted Bypass Regulator

Adjustable base pressure from 2 to 20 PSI-recommended for A-2000; P/N 11202 and Belt Drive; P/N 11105 Drag Race fuel pumps. Ideal for use with high volume electric or mechanical fuel pumps of any make, where dynamic flow and rock steady pressure control is desired. Fittings Sold Separately.
AER13202.....\$199.71

A4 Carbureted Regulator

This is the only four-port regulator on the market that uses a "soft seat" design, eliminating pressure creep at idle and on the throttle stop. Used by many of the best "Super Class" racers in the country. Adj from 5-15 PSI. Fittings Sold Separately.
AER13203.....\$246.52

A1000 Carbureted Bypass Regulator

Perfect from the street to the track, naturally aspirated or super-charged. One -10 AN inlet and one -8 AN return port with two -6 AN outlet ports and 1/8" NPT gauge port. Stainless steel vacuum boost port - ideal for turbo-charged or supercharged engines. Fuel pressure rises on a 1:1 ratio with boost. Requires return line from bottom of regulator to top of tank. Fittings Sold Separately.
AER13204.....\$188.81

Pro-Stock, 2-Port Regulator

Designed to be used with the A2000 Fuel Pump (P/N 11202) in either single or dual carb applications. Adjustable from 4-8 PSI. ORB-12 inlet port. (Includes AN-12 to AN-10 male flare reducer fitting). P/N 13208 provides (4) ORB-06 outlet ports. P/N 13210 provides (2) ORB-08 outlet ports. 1/8" NPT gauge port. Includes mounting bkt.
4-Port.....AER13208\$286.31
2-Port.....AER13210\$242.99

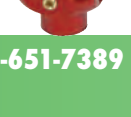
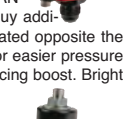
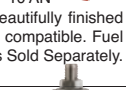

Double Adj. Bypass Regulator

AER13209

Revolutionary design provides two independent pressure adjustments; one adjustment for idle and one for wide open throttle. Engineered for use with variable volume pumps tied to engine RPM. This regulator creates the smoothest and most repeatable fuel curve from idle to wide open throttle of any bypass system.

- ORB-10 return port.
- AER13209 provides (1) ORB-08 inlet and (3) ORB-08 outlet ports.
- AER13214 available with fuel log AER14201 or AER14202, fittings and gauge as AER17249 or AER17251.
- Can be configured for single or dual carbureted engines and provides superior pressure control and flow when installed before the carburetor or after a fuel log.
- Also available with a single inlet port for fuel logs. (AER13214) - provides ORB-10 inlet and return ports.

AER13214

Double Adjuster Bypass RegulatorAER13209...\$255.41
Double Adjuster Bypass 2-Port Regulator.....AER13214...\$250.42

ORB-08 / AN-06 Male Flare Reducer Fitting ...AER15605...\$16.73
ORB-06 / AN-06 Male Flare FittingAER15606...\$13.64
ORB-08 / AN-08 Male Flare FittingAER15607...\$16.79
ORB-10 / AN-10 Male Flare FittingAER15608...\$16.86
ORB-10 / AN-06 Male Flare Reducer Fitting ...AER15609...\$18.04
ORB-10 / AN-08 Male Flare Reducer Fitting ...AER15610...\$18.04
ORB-12 / AN-12 Male Flare FittingAER15612...\$28.89
ORB-12 / AN-10 Male Flare Reducer Fitting ...AER15613...\$29.49
ORB-04 / AN-04 Male Flare FittingAER15629...\$14.40



Cutoff Fittings

In-Line Fuel Filter

High-flow, 10-micron fabric (fine) replaceable element. • Flows 2,000 lb/hr with a pressure drop of less than 1 PSI.

RedAER12301...\$105.00
BlackAER12321...\$114.99

High-flow, 100-micron stainless steel (coarse) cleanable element. • Flows 2,000 lb/hr with a pressure drop of less than 0.5 PSI.

RedAER12304...\$129.40
BlackAER12324...\$135.99

SS Series Fuel Filter

• 3/8" NPT ports • Red, type II bright dip anodized finish • Compact size: 3.5" long x 1.25" diameter

40-micron fabric replaceable element.....AER12303...\$99.99
100-micron stainless steel (coarse) cleanable element.....AER12316...\$90.51

In-Line Fuel Filter

Designed to stand up to the destructive properties of alcohol based fuels, including ethanol and methanol.

High-flow, 40-micron stainless steel, cleanable element. ORB-10 ports. Fittings available to adapt these filters to AN-10, -08 and -06 line sizes. Size: 5.5" long x 2" dia.

AER12335\$136.79

Pro Series Fuel Filter

ORB-12 ports. Fittings available to adapt these filters to AN-12, -10 line sizes. Pro-Series filters feature an indestructible electroless nickel finish. 7" long x 2.5" diameter.

High flow, 10 micron fabric (fine) replacement element. Flows 2,000 lb/hr with a pressure drop of less than .5 PSIAER12310...\$154.82

High flow, 100 micron stainless steel (coarse) cleanable element. Flows 2,000 lb/hr w/a pressure drop of less than .15 PSI ...AER12302...\$184.37

In-Line Fuel Filters w/Integrated Male Flare Ends

AN-06 Male Ends
10-m Microglass Element, AN-06 Male, Black, 2" ODAER12345...\$143.43

10-m Fabric Element, AN-06 Male, Black, 2" ODAER12347...\$118.04

40-m Stainless Mesh Element, AN-06 Male, Black, 2" ODAER12348...\$143.33

100-m Stainless Mesh Element, AN-06 Male, Black, 2" ODAER12349...\$143.33

AN-08 Male Ends
10-m Microglass Element, AN-08 Male, Black, 2" ODAER12375...\$143.43

10-m Fabric Element, AN-08 Male, Black, 2" ODAER12377...\$118.04

40-m Stainless Mesh Element, AN-08 Male, Black, 2" ODAER12378...\$143.33

100-m Stainless Mesh Element, AN-08 Male, Black, 2" ODAER12379...\$143.33

AN-10 Male Ends
10-m Microglass Element, AN-10 Male, Black, 2" ODAER12385...\$143.43

10-m Fabric Element, AN-10 Male, Black, 2" ODAER12387...\$118.04

40-m Stainless Mesh Element, AN-10 Male, Black, 2" ODAER12388...\$143.33

100-m Stainless Mesh Element, AN-10 Male, Black, 2" ODAER12389...\$143.33

4 Port Fuel Distribution Log

(2) ORB-08 Ports and (2) ORB-06 Ports
AER14601...\$69.31

High Flow "Y" Block

Features (1) ORB-10 Port to (2) ORB-08 Ports...AER15620...\$98.99

Fuel Pressure Gauge

0-15 PSI (1-1/2") ...AER15632...\$41.13

0-100 PSI (1-1/2")...AER15633...\$41.13

Fuel Pressure Gauge MOROSO

Compact 1.5 inch dia. gauge can be mounted to fuel regulator or fuel block for convenient fuel pressure tuning. Includes 1/8" NPT Male Fitting

0-15 psiMOR65370...\$40.64

0-100 psiMOR65374...\$40.64

Fuel Pressure Gauge 0-15 PSI

Now you can know what your fuel pressure is at a glance with this easy to read 0-15 psi fuel pressure gauge.

Standard.....EAR100195...\$20.43
Oil Filled.....EAR100189...\$31.60



Fuel Systems

This system includes everything needed for a complete Aeromotive system installation in a carbureted application. All systems include fuel pump, filters, regulator, port fittings, stainless steel braided hose, hose-ends, wiring and installation hardware.

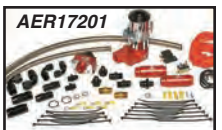

SS Carbureted Fuel System.....AER17201\$895.99

• AER11203 Fuel Pump • AER13201 Fuel Pressure Regulator

A1000 Carbureted Fuel System (single carb)AER17242\$1553.14

• AER11101 A1000 Fuel Pump • AER13204 Fuel Pressure Regulator

A750 EFI Fuel System.....AER17136\$1687.95

• AER11106 A750 EFI Fuel Pump • AER13109 Fuel Pressure Regulator

A1000 EFI Fuel System.....AER17125\$1911.16

• AER11101 A1000 Fuel Pump • AER13101 Fuel Pressure Regulator

Eliminator EFI Fuel System.....AER17126\$2275.99

• AER11104 Eliminator Fuel Pump • AER13101 Fuel Pressure Regulator

Canister Style Fuel Filter

When an in-line fuel filter just won't work, these canister fuel filters are engineered to provide max flow with limited pressure drop in a canister style filter. • 3/8" NPT ports. • 6.125" tall x 3.75" diameter

High flow, 10 micron fabric (fine) element.

Flows 1,500 lb/hr with a pressure drop of less than 1 PSI.

Red.....AER12308...\$97.99

Black.....AER12317...\$103.70

High flow, 100 micron stainless steel (coarse) cleanable element.

Red.....AER12318...\$133.99

Black.....AER12319...\$116.48

Shutoff Valve Fuel Filter

It allows you to shutoff fuel flow and replace your filter elements with little or no fuel loss. Both feature 100 micron stainless steel elements and are recommended for use between the fuel cell or sumped tank and the fuel pump inlet.

ORB-10 portsAER12331...\$227.99

ORB-12 ports.....AER12332...\$230.92

Replacement Elements

By simply replacing &/or cleaning your filter elements regularly, you can avoid costly repairs to your fuel system and ensure peak engine performance.

AER12601\$16.11.....10 micron fabric element for

12301, 12306

AER12602\$72.07ProSeries 100 micron st element for

12302, 12332, 12309.

AER12603\$19.6740 micron fabric element for 12303

AER12604\$40.91100 micron fabric element for 12304, 12331, 12307

AER12608\$16.6010 micron fabric element for 12304, 12331, 12307

AER12610\$21.36Pro Series 10-micron fabric element for 12310, 12311

AER12616\$27.30100-micron stainless element for 12316

AER12618\$59.80100-micron stainless element for 12318, 12319

AER12635\$40.9140-micron stainless element for 12335

Billet Fuel Rails Kits

High Flow, Billet Fuel Rails combine 3,000 HP flow capabilities with "bolt-on" ease of installation. ORB-08 Ports with compact connections and positive, leak-free sealing. Full 5/8" ID through bore, capable of supporting up to 3,000 HP. Fully compatible with -10 AN line if combined with custom ORB-08/AN-10 adapter AER15641.

Ford 4.6 L Mustang 96-04 SOHC GT KitAER14103\$276.76

Ford 4.6 L Mustang 96-98 1/2 DOHC Cobra KitAER14104\$262.99

Ford 5.0 L Mustang 86-95 GT & Cobra KitAER14101\$265.43

Ford 5.0 L Mustang 86-95 GT & Cobra, Return Style.....AER14102\$772.29

GM 97-04 LS1, 01-05 LS6 Kit.....AER14106\$262.99

Y-Blocks

This CNC-machined, billet aluminum. Y-Blocks feature A/N Style Male inlets and outlets, which eliminate potential leak paths, fittings, O-Rings and "cost".

-12 to (2) -12AER15679...\$84.93

-12 to (2) -10AER15678...\$61.03

-12 to (2) -8AER15677...\$62.39

-10 to (2) -10AER15676...\$51.53

-10 to (2) -8AER15675...\$50.46

-8 to (2) -8AER15674...\$61.03

-8 to (2) -6AER15673...\$47.47

-8 to (2) -4AER15672...\$47.44

-6 to (2) -4AER15671...\$47.44



Fuel Pump/Filter Brackets and Clamps

Billet 2.5" Pump/Filter Bracket. Can be used with the following fuel pumps and filters:

Fuel Pumps: 11103, 11106, 11156, 11211, 11212 11203, 11213, 11209, 11219, 11253, 11259.

Filters: 12302, 12310, 12332, 12309, 12311, 12352, 12360.
AER11703...\$97.80

2.5" T-Bolt Clamp Can be used with the following fuel pumps and filters:

Fuel Pump: 11103, 11106, 11156, 11211, 11212 11203, 11213, 11209, 11219, 11253, 11259.

Filters: 12302, 12310, 12332, 12309, 12311, 12352, 12360.
AER12702...\$19.94

Billet 2" Filter Bracket. Can be used with the following fuel filters:

Filters: 12301, 12304, 12306, 12307, 12321, 12324, 12351, 12354, 12331.
AER12305...\$82.01

Horizontal Drag



Horizontal Cells

5 Gal. (13" x 13" x 8")JAZ250-005-01\$141.75
Mounting KitJAZ400-005-03\$38.21
8 Gal. (20" x 15" x 7.5")JAZ250-008-01\$153.80
Mounting KitJAZ400-008-03\$39.97
12 Gal. (17.5" x 16" x 10")JAZ250-012-01\$168.89
Mounting KitJAZ400-012-03\$43.20
16 Gal. (25" x 17" x 9")JAZ250-016-01\$220.16
Mounting KitJAZ400-016-03\$43.49

NHRA Drag

SFI 28.1 Certified NHRA Pro Stock Accepted 1.5 Gal Pro Stock I Fuel Cells

- Aircraft Style Flush Mount Cap Assembly
 - 1 AN -10 Fast Flow Outlet Fitting in the Sump
 - 1 AN -8 Return Fitting w/Anti-Aeration Tube
 - 1 AN -8 Tip Over Valve Vent Fitting
- (7" x 9" x 8-1/2")JAZ220-015-01\$409.10
 Mounting KitJAZ400-002-03\$38.21



SFI-28-1 Certified

Circle Track Cells

Flat Bottom Pro Street w/ Sender

Safety Foam Filled w/0-90 Ohm Sender



12 Gallon Cell (17.5" x 16" x 10")JAZ202-012-01\$256.22
Mounting KitJAZ400-012-03\$43.20
16 Gallon Cell (25" x 17" x 10")JAZ202-016-01\$270.81
Mounting KitJAZ400-016-03\$43.49
22 Gallon Cell (25" x 25" x 9")JAZ202-022-01\$316.99
Mounting KitJAZ400-022-03\$47.03



RRPR14-005



RRPR17-001-09

Quick Fill Fuel Components

Re-Fueling Probe.....RRPR17-001-09.....\$445.50	RRPR16-012
Replacement Bellow.....RRPR17-002.....\$26.25	
Female Dry Break.....RRPR15-001.....\$315.00	
1.25" Vent w/spring.....RRPR16-001.....\$63.00	
Catch Can w/probe.....RRPR14-005.....\$70.00	
1.25" Billet Fuel Cell	
Vent w/ 90 deg bend.....RRPR16-012.....\$203.00	



RRPR15-001

12 Gal Alum Quick Fill Dump Cans

RRPR14-001-2.....\$322.00

Fuel Overflow Catch Can

Alum can will catch overflow when refueling. Includes 6" rod for use w/check valve & clear hose splash guard. 1.5 gallon capacity.
 ALL10102.....\$62.99

Quick Fill Can

Aluminum fill can has an 11 gallon capacity and is ideal for quick pit stops. 45° neck eliminates unnecessary elbows and assures quick flow.
 ALL10100.....\$144.99

Dry Break Redhead Valve

Spring loaded female receptacle mts in a variety of locations & automatically closes when male dry break is removed. Female dry break accepts 2-1/2" fuel hose. Male dry break accepts 2-1/4" fuel hose.
 FemaleALL40213\$244.99
 MaleALL40215\$264.99

Overflow Check Valves

Valves are 9-3/4" long and available in two styles. Use with ALL10102 overflow catch can.
 ALL40203.....\$77.99

Vertical Drag



1 Gallon Vertical Cell

l x w x h	Part #	Price
6" x 6" x 12"	JAZ250-001-01	\$144.20
Straps	JAZ400-001-03	\$38.21

3 Gallon Vertical Cell

8-1/4" x 8-1/4" x 14-1/2"		
JAZ250-003-01\$141.75	
Straps	JAZ400-003-03\$38.21



5 Gallon Vertical Cell

9" x 11" x 18"		
JAZ250-105-01\$144.11	
Straps	JAZ400-105-03\$38.21



2 Gallon Pro Stock Cell

7" x 9" x 10"		
JAZ220-002-01\$409.10	
Straps	JAZ400-002-03\$38.21



SFI-28-1 Certified

SFI 28.1 Certified 3 Gallon Pro Stock Cell

8" x 8" x 15"		
JAZ220-303-01\$414.21	
Straps	JAZ400-303-03\$38.21



SFI-28-1 Certified

SFI 28.1 Certified 3 Gallon Pro Modified Cell

8-1/4" x 8-1/4" x 14-1/2"		
JAZ220-003-01\$423.56	
Straps	JAZ400-003-03\$38.21



SFI-28-1 Certified



1 Gallon Nitrous Enrichment Cell

l x w x h	Part #	Price
6" x 6" x 12"	JAZ220-001-01	\$169.05
Straps	JAZ400-001-03	\$38.21



Flow Max Cell

Size	l x w x h
2 Gal. Cell	10" x 12" x 12"
JAZ240-202-01\$345.53

Straps	JAZ400-202-03\$32.91
--------	---------------	--------------



3 Gal. Cell	11" x 13-1/2" x 13-1/2"
JAZ240-203-01\$345.53

Straps	JAZ400-203-03\$32.91
--------	---------------	--------------

SFI-28-1 Certified

Aluminum Cells



3 Gallon Fuel Cell

3 Gal. 8-1/8" x 8-1/8" x 15-1/2"
 JAZ210-503-03\$211.06



4 Gallon Fuel Cell

4 Gallon 12-1/2" x 10-1/8" x 8-1/8"
 JAZ210-504-03\$222.95



5 Gallon Fuel Cell

5 Gallon 12-1/8" x 12-1/8" x 8-5/8"
 JAZ210-505-03\$240.26



10 Gallon Fuel Cell

10 Gallon 16-5/8" x 16-5/8" x 9-1/4"
 JAZ210-510-03\$303.69



15 Gallon Fuel Cell

20-1/4" x 18-1/8" x 10-1/4"
 JAZ210-515-03\$342.58
 20-1/4" x 18-1/8" x 10-1/4" w/0-90 sending unit
 JAZ210-615-03\$389.84



20 Gallon Fuel Cell

20-1/4" x 24-1/4" x 10-1/8"
 JAZ210-520-03\$398.24
 20-1/4" x 24-1/4" x 10-1/8"
 w/0-90 sending unit
 JAZ210-620-03\$435.81



Jr. Drag Cells

Size l x w x h
 1 Qt. Cell 4" x 4" x 10-1/4"
 JAZ230-025-01\$52.45 JAZ230-025-01

2 Qt. Cell 7-1/4" x 4" x 5-1/2"
 JAZ230-050-01\$71.64

Straps..JAZ400-050-03. \$37.14

1 Gal. Cell 6" x 6" x 12"
 JAZ230-001-01\$137.42

Straps..JAZ400-001-03.....\$38.21

JAZ230-001-01

JAZ290-103-01

JAZ290-103-01

JAZ290-103-01

JAZ290-103-01

JAZ290-103-01

JAZ290-103-01

JAZ290-103-01

JAZ290-103-01

JAZ290-103-01

JAZ290-103-01

JAZ290-103-01

JAZ290-103-01

JAZ290-103-01

Circle Track Cells



Oval Track

Safety Foam Filled

8 Gallon (20" x 15" x 7.5")
CellJAZ200-008-01...\$158.25
Straps...JAZ400-008-03...\$39.97

10 Gallon (25" x 9" x 12")
CellJAZ200-010-01...\$167.54
Straps...JAZ400-010-03...\$39.97

12 Gallon (17.5" x 16" x 10")
CellJAZ200-012-01...\$166.54
Straps...JAZ400-012-03...\$43.20

16 Gallon (25" x 17" x 10")
CellJAZ200-016-01...\$200.11
Straps...JAZ400-016-03...\$43.49

16 Gallon (18-1/2" x 18-1/2" x 12")
CellJAZ200-116-01...\$204.11
Straps...JAZ400-016-03...\$43.49

22 Gallon (25" x 25" x 9")
CellJAZ200-022-01...\$253.69
Straps...JAZ400-022-03...\$47.03

22 Gallon (33" x 17-3/4" x 10")
CellJAZ200-122-01...\$234.70
Straps...JAZ400-122-03...\$41.73

22 Gallon (25" x 17" x 14")
CellJAZ200-222-01...\$252.64
Straps...JAZ400-222-03...\$47.03

32 Gallon (33" x 17" x 14")
CellJAZ200-032-01...\$295.09
Straps...JAZ400-032-03...\$52.32

32 Gallon (26" x 18" x 18")
CellJAZ200-132-01...\$295.09
Straps...JAZ400-132-03...\$45.25

Oval Track Cells w/ Cans



Foam filled w/ tip over valve

Pro Sport Cells

4 Gallon 13" x 11-1/8" x 9-1/8"

Cell...JAZ270-004-06.....\$213.87

8 Gallon 20-5/8" x 15-1/2" x 8-3/8"

Cell...JAZ270-008-06.....\$252.36

12 Gallon 18" x 16-1/2" x 10-1/2"

Cell...JAZ270-012-06.....\$262.86

16 Gallon 26" x 18" x 10"

Cell...JAZ270-016-06.....\$342.31

16 Gallon 19" x 19" x 12-1/2"

Cell...JAZ270-116-06.....\$348.54

22 Gallon 25-5/8" x 25-5/8" x 9-1/4"

Cell...JAZ270-022-06.....\$451.51

22 Gallon 34-1/2" x 18-3/4" x 10-1/2"

Cell...JAZ270-122-06.....\$446.18

22 Gallon 25-3/4" x 17-3/8" x 14-1/2"

Cell...JAZ270-222-06.....\$469.80

32 Gallon 34" x 17-3/8" x 14-3/8"

Cell...JAZ270-032-06.....\$575.01

32 Gallon 26-5/8" x 18-5/8" x 18-5/8"

Cell...JAZ270-132-06.....\$473.42

Late Model Specialized

Pro Sport Cells

32 Gal 26-5/8" x 18-5/8" x 18-5/8"

Red...JAZ270-532-06...\$489.31

22 Gallon

Pro Lite Fuel Cell

25" x 16-3/4" x 13-3/4"

JAZ285-622-03...\$658.12

Late Model Cell

Man O' War

Designed for Dirt Late Model and Dirt Modified applications. Fits all popular chassis including Edge Chassis and Rage Chassis.

22 Gallon 21-1/4" x 18-7/8" x 18-7/8"

JAZ285-722-01...\$677.19



Fuel Cell Accessories



Bail Handle Cap

Replacement cap for circle track fuel cells. Can be used for custom fuel tank construction. Assembly comes with all hardware and gaskets.

Bail Handle Cap Assembly.....JAZ350-301-03...\$61.62
Replacement Cap.....JAZ340-300-09...\$41.39
12 Hole Flange Gasket.....JAZ850-301-01...\$4.12
Bail Handle Cap Gasket.....JAZ850-300-01...\$4.12



Aircraft Style Flush Cap

Available in small 6 bolt, or large 12 bolt styles. 6 bolt is replacement cap for drag race fuel cells. 12 bolt can be used on circle track fuel cells. Features an aircraft style positive lock mechanism. Built-in one way check valve vent. Can be used for custom fuel tank construction. Assembly comes with all hardware and gasket.

6 Bolt Flush Cap Assembly.....JAZ350-201-06...\$70.29
12 Bolt Flush Cap Assembly.....JAZ350-202-06...\$136.07
Replacement Cap.....JAZ340-200-06...\$38.81
6 Hole Flange Gasket.....JAZ850-201-01...\$4.12
12 Hole Flange Gasket.....JAZ850-301-01...\$4.12
Replacement Cap Gasket.....JAZ850-200-01...\$5.72

Dragster Fillers

Cast aluminum filler to replace 6 bolts caps. Great for dragsters with behind seat fuel cells. Available in straight or 45° styles. Short styles are approximately 5" long. Long styles are approximately 9" long. Comes with complete with all hardware and gasket.

45° short filler neck assembly...JAZ345-251-03...\$109.87
45° long filler neck assembly...JAZ345-252-03...\$132.79
Straight short filler assembly...JAZ390-251-03...\$109.24
Straight long filler assembly...JAZ390-252-03...\$121.40

Fast Fill Valves

Cast aluminum filler to replace 12 bolts D-ring caps. Features a spring loaded flapper for roll over protection. Available in straight or 45° styles. Filler neck available in 2-1/4" and 2-1/2" diameters. Gasket and bolt rings sold separately.

45° 2-1/4" filler valve.....JAZ345-225-03...\$107.80
45° 2-1/2" filler valve.....JAZ345-250-03...\$107.80
Straight 2-1/4" filler valve.....JAZ390-225-03...\$109.48
Straight 2-1/2" filler valve.....JAZ390-250-03...\$109.48
Split Nut Ring (required).....JAZ315-030-03...\$27.76
Replacement flange gasket...JAZ850-301-01...\$4.12

Fuel Level Sending Unit

70-10 ohm 8" long.....JAZ378-070-03...\$118.68
70-10 ohm 11" long.....JAZ371-070-03...\$123.55
0-90 ohm 8" long.....JAZ378-090-03...\$118.93
0-90 ohm 11" long.....JAZ371-090-03...\$120.43
240-33 ohm 8" long.....JAZ378-240-03...\$119.11
240-33 ohm 11" long.....JAZ371-240-03...\$122.28

Poly Washers

AN -6.....JAZ850-506-04...\$1.40
AN -8.....JAZ850-508-04...\$1.40
AN -10.....JAZ850-510-04...\$1.40
AN -12.....JAZ850-512-04...\$1.41
AN -16.....JAZ850-516-04...\$1.41

AN Cap & Plug Kit

It has 4 each of sizes -6, -8, -10, -12 and -16.
JAZ730-000-11...\$15.94

Bat Wing Pickup

Designed to keep fuel pickup hose in place. Keeps pickup hose in lower corner of fuel cell. Designed to be used with 1/2" diameter hose. Must be used with foam to function properly.
JAZ305-050-01.....\$25.06



Fender Filler Kit

To be used with remote fill fuel cells. Can be adapted to other brands of cells. Can be adapted to other brands of cells. Recessed fender filler cap flange. Bright Zinc plated steel. Vented twist lock cap assembly. 3 feet of clear fuel approved filler hose. AN -8 to 1/2" hose barb fitting for vent line. 3 feet of 1/2" clear vent line hose. Can use split nut rings for mounting.

6 bolt hole 2-1/4" filler kit.....JAZ300-001-20...\$124.42
12 bolt hole 2-1/2" filler kit.....JAZ300-000-20...\$124.03
6 bolt split nut ring.....JAZ315-030-03...\$27.76
12 bolt split nut ring.....JAZ315-040-03...\$27.76

Fuel Cell Safety Foam Kit

-001 cells.....JAZ360-001-11.....\$29.00
-002 cells.....JAZ360-002-11.....\$29.00
-003 cells.....JAZ360-003-11.....\$32.45
-004 cells.....JAZ360-004-11.....\$32.45
-005 cells.....JAZ360-005-11.....\$35.36
-008 cells.....JAZ360-008-11.....\$58.04
-010 cells.....JAZ360-010-11.....\$69.10
-012 cells.....JAZ360-012-11.....\$76.18
-016 cells.....JAZ360-016-11.....\$95.15
-022 cells.....JAZ360-022-11.....\$114.74
-032 cells.....JAZ360-032-11.....\$161.48
-103 cells.....JAZ360-103-11.....\$32.72
-104 cells.....JAZ360-104-11.....\$32.61
-105 cells.....JAZ360-105-11.....\$35.54
-116 cells.....JAZ360-116-11.....\$109.56
-122 cells.....JAZ360-122-11.....\$114.98
-132 cells.....JAZ360-132-11.....\$161.48
-202 cells.....JAZ360-202-11.....\$29.00
-203 cells.....JAZ360-203-11.....\$32.45
-222 cells.....JAZ360-222-11.....\$114.98
-303 cells.....JAZ360-303-11.....\$32.45



12-Bolt Fill Valve/Check Valve Flapper

This 12-bolt Fill Valve with Check Valve Flapper can be retrofitted to bolt onto any our standard 12-hole pattern cap assemblies. It has a 2-1/4" O.D. fill tube and twist-lock cap. It features a bolted-in plastic flapper for rollover protection and comes standard with an AN-10 Tip Over Valve Vent fitting. Designed to be used on fuel cells with or without who require rollover protection, but do not want the extra cost of a spring-loaded flapper. Fuel cells built with this new filler installed will also come with a bat wing attached to the pick-up hose to prevent the hose from curling or moving.

12-Bolt Fill Valve / Check Valve Flapper
JAZ391-251-03.....\$82.39

Fuel Cell Tip Over Valve

AN -6.....JAZ834-006-11...\$24.82
AN -8.....JAZ834-008-11...\$25.71

Fuel Cell Tip Over/Breather Valve

AN-8 Breather
JAZ834-108-06...\$35.16

Fuel Cell External Tip Over Valve

AN-6.....JAZ834-206-06...\$29.34
AN-8.....JAZ834-208-06...\$29.34

Fuel Cell Fast Flow Fittings

AN -6.....JAZ832-106-11...\$15.87
AN -8.....JAZ832-108-11...\$17.12
AN -10.....JAZ832-110-11...\$24.80
AN -12.....JAZ832-112-11...\$32.17
AN -16.....JAZ832-116-11...\$49.22

Dirt Modifieds



24 Gallon Complete Fuel Cell

24 Gallon 100 Series Super Cell regular fill in aluminum shoe box container, measures 25 x 17 x 14.5 comes with #8 or #10 pickups, includes dipstick.

ATLSU124B-AC.....\$1367.52

100 Series Bladder - 24 Gallon

Replacement 100 Series lightweight bladder and foam for SU124B

ATLFB124B.....\$810.64

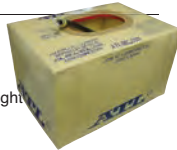

22 Gallon Super Cell Steel Can

22 Gallon 100 Series Super Cell. Regular fill plate in steel container, measures 25 x 16.75 x 13.75" #8 outlet, used in Dirt mods and SK mods

ATLSU122B.....\$1270.15



100 Series Bladder 22 Gallon

Replacement 100 Series lite weight bladder and foam for SU122B

ATLFB122B.....\$766.75



22 Gallon Sports Cell w/Steel Can

22 Gallon B- Size Sports Cell regular fill plate in steel container, measures 25 x 16.75 x 13.75 #8 outlet, used in Dirt mods.

ATLSP122B.....\$1085.55



22 Gallon Replacement

Saver Cell & Sports Cell Bladder

Replacement rotational molded bladder and foam for SP122B.

ATLMB122B.....\$507.26



24 Gallon Aluminum Replacement Fuel Can

Size: 17" x 25" x 14.5"
BSC90500...\$247.95

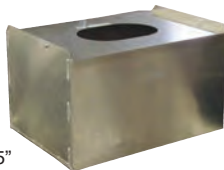

Dirt Late Models

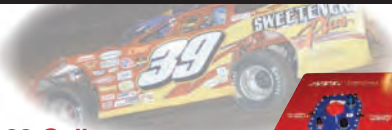

22 Gallon Dirt Late Model Style Sports Cell

It measures 25.13" x 16.75" x 13.75"
Add - B for Black. W- for White. or ACAF for lightweight Alum can and Alum Fill (28 lbs.)

ATLSP122B-LM.....\$932.06



26 Gallon Dirt Late Model Style Sports Cell

It measures 25.25" x 16.85" x 17.25"
Add - B for Black. W- for White. or ACAF for lightweight Alum can and Alum Fill (35 lbs.)

ATLSP126C-LM.....\$942.17



26 Gallon LW C-Size Dirt Late Model 100 Series Sports Cell

This cell measures at 25.25" x 16.85" x 17.25". Its in Aluminum Can Only and weighs just 25 lbs.

ATLSU126C-LM-AC.....\$1512.21

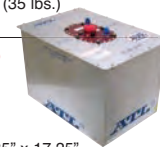

32 Gallon Dirt Late Model Style Sports Cell

It measures 26.13" x 19.00" x 17.18"
Add - B for Black. W- for White. or ACAF for lightweight Aluminum can and Aluminum Fill.

ATLSP132B-LM\$1001.76



Asphalt Modified

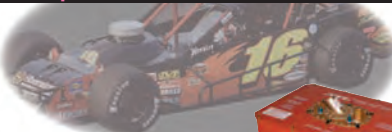

200 Series 22 Gallon Super Cell

22 Gallon B-Size 200 Series Super Cell, NASCAR approved measures 25 x 16.75 x 13.75 includes TF193A-184A quick fill & steel container. NASCAR touring mods.

ATLSU222B...\$1732.99



Replacement Bladder - 22 Gallon

Replacement 200 Series 22 Gallon B-Size Bladder and foam for the SU222B

ATLFB222B...\$937.04



22 Gallon SK Mods

22 Gallon B-Size 100 Series Super Cell regular fill plate in steel container, measures 25 x 16.75 x 13.75 #8 outlet, used in SK and weekly modifieds

ATLSU122B.....\$1270.15



100 Series Bladder 22 Gallon

Replacement 100 Series lite weight bladder and foam for SU122B

ATLFB122B.....\$766.75



15 Gallon SK Mods

15 Gallon 100 Series Super Cell, regular TF600 fill plate, steel container measures 24.5 x 17.75 x 9.5, #8 outlet, used in SK and Weekly asphalt mods

ATLSU115.....\$1078.90



100 Series Bladder - 15 Gallon

Replacement 100 Series 15 Gallon Bladder and foam for the SU115

ATLFB115.....\$658.35



Asphalt Late Mods

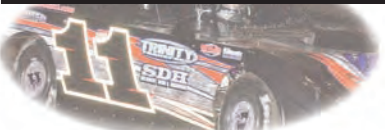

22 Gallon E-Size 100 Series Super Cell

22 Gallon E-Size 100 Series Super Cell. regular fill plate in steel container, measures 33 x 17 x 9.25 #8 outlet, used in Asphalt Late Models.

ATLSU122E.....\$1270.15

100 Series Bladder 22 Gallon

Replacement 100 Series E-Size lightweight bladder and foam for SU122E

ATLFB122E.....\$766.75



22 Gallon 100 Series Super Cell

Gallon C-size 100 Series Super Cell. Regular fill plate in steel container, measures 34 x 17.5 x 9.5 #8 outlet, used in asphalt late models

ATLSU122C.....\$1270.15



100 Series Bladder- 22 Gallon

Replacement 100 Series C-size lightweight bladder and foam for SU122C

ATLFB122C....\$766.75

22 Gallon C-Size Sports Cell

22 Gallon C-Size Sports Cell regular fill plate in steel container, measures 34 x 17.5 x 9.5 #8 outlet

ATLSP122C.....\$1085.55



Sprint Car

28 Gallon Kinser Designed Sprint Cell

28 gallon ATL style LW Complete Sprint Cell with mounting inserts. Only 21 lbs!

ATLSC428.....\$2047.50



Replacement Tail Tank for 28 Gal

ATLTT428.....\$349.70

Replacement 28 Gal Bladder

ATL Style..ATLFB428...\$1368.90



28 Gallon Sprint Cell

28-Gal Fuel Safe Style LW Complete Sprint Cell w/mounting inserts

ATLSC428-FS.....\$2101.25



Replacement Tail Tank for 28 Gallon

ATLTT428-FS.....\$318.72

Replacement Bladder 28 Gallon

Fuel Safe Style.....ATLFB428-FS\$1424.80

Road Racing



8 Gallon Sports Cell

8 Gallon Sports Cell, includes standard fill in steel container, measures 20.5 x 12.4 x 9.1. SCCA, NASA and Vintage approved
ATLSP108.....\$787.09

10 Gallon Sports Cell

10 Gallon Sports Cell, includes standard fill in steel container, measures 24.75 x 12.84 x 10.25. SCCA, NASA and Vintage approved
ATLSP110.....\$804.25

12 Gallon Sports Cell

12 Gallon Sports Cell, includes standard fill in steel container, measures 20.5 x 17.75 x 9.5. SCCA, NASA and Vintage approved
ATLSP112.....\$883.52

15 Gallon Sports Cell

15 Gallon Sports Cell, includes standard fill in steel container, measures 24.5 x 17.75 x 9.5. SCCA, NASA and Vintage approved
ATLSP115.....\$923.82

12 Gallon Well Cell

12 Gallon Well Cell 22 diameter 9" tall. SCCA, NASA and Vintage Approved
ATL171110.....\$492.05

3 Door Surge

w/High Pressure Pump

In-Tank 100 PSI pump & Surge Tank Includes: 3-Door Surge Tank • ATLTf602 Bulkhead • 5/16" Flex Tube • Wire Bulkhead • Filter Sock • Clamps • Diagram • ATLCFD 104 Pump • Wire Harness • ATLCFD-600-HP....\$468.32

3-Door Molded Surge Tank

5" x 5" x 6" • .6 Gallon for Road Race & Rally Applications. #8 AN (Optional) #6 "ScavenJet 1" ATLTf479
ATLST528.....\$224.42

5-Gallon Vent Bottle w/Elbow

5 Gallon/20 Liters Nom. It is foam-filled and mates with a dry break valve (not included) to collect vent overflow during pit stop fueling. It's a great "top-off" refueler bottle too! Elbow hose included. 13" dia. x 36" tall.
ATLRE169.....\$264.33

Methanol

26 Gal Saver Cell Complete

25" x 16" x 17", w/Methanol Compatible Foam Baffling.
ATLSA126C-MF.....\$call

26 Gal Sports Cell Complete

25" x 17" x 17", w/Methanol Compatible Foam Baffling.
ATLSP126C-MF.....\$call

24 Gal FluoroCell "600" Series Complete

25" x 17" x 15", w/Methanol Compatible Foam Baffling.
ATLSU624B-MF.....\$call

28 Gal Black Widow Dirt Late Model Complete

21.25"x24"x21.1" w/Methanol Compatible Foam Baffling.
ATLSP128-LM-MF.....\$call

26 Gal Sports Cell Dirt Late Model Complete

25" x 17" x 17", w/Methanol Compatible Foam Baffling.
ATLSP126C-LM-MF.....\$call

32 Gal Sports Cell Dirt Late Model Complete

26" x 19" x 17", w/Methanol Compatible Foam Baffling.
ATLSP132B-LM-MF.....\$call

Accessories



Replacement Foam

8 Gallon.....	ATLBF608.....	\$90.02
10 Gallon.....	ATLBF610.....	\$102.20
12 Gallon.....	ATLBF612.....	\$114.80
15 Gallon.....	ATLBF615.....	\$143.08
22 Gallon, E-size.....	ATLBF622E.....	\$187.60
22 Gallon, B-size.....	ATLBF622B.....	\$187.60
24 Gallon.....	ATLBF624B.....	\$214.76

Regular Fill "Flap-Valve"

Anodized Aluminum Assembly

Standard Aluminum fill plate includes 2.25" twist on cap with rollover valve, #6 rollover vent valve, and (2) #6 or #10 outlets.
ATLTF600.....\$182.61

Quick Fill

"Paddle Valve" Assembly Alum, Spring Load "Bullet" Vent

Paddle Valve Quick fill plate with 2.25" 45 degree fill with paddle, 1.5" vent valve, #6 dipstick and (2) #8 outlets.
ATLTF525.....\$530.47

Regular Fill "Flap-Valve"

Powder Coated Steel Assy

2-1/4" O.D. 3" Tall Fill Neck, (2) #8 Out., (1) #6 Vent Valve, Cap & Flap Valve
ATLTF195.....\$172.95

Seal Kit

Gaskets, Seals, Flapper, Bolts and Washers. For ATLTf193A-184A, ATLTf183A, ATLKS161.....\$62.30

Heavy Duty Gasket

6" x 10" Dual

24 Bolt
ATLTF217.....\$9.94

4-3/4" B.C. 12 Bolt

ATLTF147.....\$6.16

4" x 6" Oval 12 Bolt

ATLTF236.....\$7.56

"Super Trick" Dump Can

11 Gallon Nom. Capacity ATL's "Super-Trick" dump can is made of seamless, impact-resistant polymer. It features smooth internal transitions, bell-mouth vent, anti-spiral vanes, shoulder recess & integral vent handle supports. Also includes a handy side-fill cap to allow filling without removing the male dry break & a sight glass window for viewing fuel flow. All of these items plus a full 2-1/4" neck combine for ultra-quick refueling times.
ATLRE103-2.....\$366.53

Dipstick Kit

#6 Dip Stick Kit includes an AN #6 Bulkhead Fitting.
ATLTF265.....\$57.68

Dip Stick w/ Threaded Cap
ATLTF207.....\$33.18

No Dip Fuel Stick

Fits Fuel Safe and ATL 24 Gallon Dirt Modified Cells and ATL 28 Gallon Rocket Dirt Late Model.
BRP9442.....\$89.23



Quick Fill Neck w/"Flapper-Valve"

4-3/4" B.C. 12 Hole
2-1/4" O.D. Fill, 90°
ATLTF183A.....\$268.96

Quick Fill Neck w/"Flapper-Valve"

4-3/4" B.C. 12 Hole
2-1/4" O.D. Fill, 45°
ATLTF184A.....\$251.16

Ultra Quick Fill Neck with "Paddle Valve"

4-3/4" B.C., 12 hole (2 sets) 3" O.D. Fill, 45°
ATLTF689-570.....\$346.52

Remote Fill Cap Alum.

Cap Assembly w/Stepped Neck accepts 2" and 2-1/4" I.D. Hose, 2" Openings, 3" B.C.
ATLTF429.....\$284.69

Cap Red

ATLTF243.....\$21.80

Recessed Cap Steel Fender Fill

2-1/4" Fill, 5" B.C. with 1/8" Drain.
ATLRF108.....\$170.43

Paddle Valve Replacement Part

12 Bolt Hole, 4.75" B.C. Patented
ATLTF570.....\$41.40

Aluminum Quick-Fill, Off-Set, "Paddle-Valve"

3" O.D. Paddle Ck Fill (22"), 1-1/2" O.D. Vent Valve (90°), (1) #8 Outlet - Dirt and Off-Road
ATLTF702.....\$896.17

Duck

Foot Fuel Pickups w/Filter/Separator

Overall Length = 22"
#6 AN (3/8") Pickup.....ATLTF239...\$51.94
#8 AN (1/2") Pickup.....ATLTF240...\$59.64
#10 AN (5/8") Pickup...ATLTF442...\$74.06

Hose Ready for use w/"Scaven-Jet II)

Has push-lock 90° fitting at end for pick-up connection. Overall Length is 22".

#8 AN (1/2") Pickup Red
ATLTF240-S.....\$59.64

#10 AN (5/8") Pickup Black
ATLTF442-S.....\$81.76

Male Red Head Dry Break

2-1/4" Male Probe, connects to dump can or overhead rig.
ATLRE105.....\$461.30

Female Red Head Dry Break

2-1/4" Female Receptacle, Mounts in Fender or deck
ATLRE104.....\$403.11

Fuel Filters

Canister Fuel Filter
PRF10100\$35.17
Replacement Filter
PRF10120\$8.84



Replacement Filters

Replacement Filter...FRAHPGC-1...\$7.95



Hi-Flow Chrome Fuel Filter

Canister-type filter flows up to 90 gallons per hour. Equipped with 3/8" NPT inlet/outlet ports and a replaceable 10 micron element.
ALL40250...\$37.99



Fuel Filters

(Paper Element Installed)
Add BK/BL/R to the end of the part # for colors.
(BK-Black, BL-Blue, or R-Red)

1/2" NPT Long Female ...KLUKRC-4905(Color) \$56.06
#6 AN Long InlineKLUKRC-4906(Color) \$56.06
#8 AN Long InlineKLUKRC-4908(Color) \$56.06
#10 AN Long InlineKLUKRC-4910(Color) \$56.06
#12 AN Long InlineKLUKRC-4912(Color) \$59.84

(Long Stainless Element Installed)

1/2" NPT Long Female ...KLUKRC-4925(Color) \$101.23
#6 AN Long InlineKLUKRC-4926(Color) \$101.23
#8 AN Long InlineKLUKRC-4928(Color) \$101.23
#10 AN Long InlineKLUKRC-4930(Color) \$101.23
#12 AN Long InlineKLUKRC-4932(Color) \$114.41

(Short Stainless Element Installed)

1/2" NPT Short Female ...KLUKRC-4705(Color) \$77.68
#6 AN ShortKLUKRC-4706(Color) \$77.68
#8 AN ShortKLUKRC-4708(Color) \$77.68
#10 AN ShortKLUKRC-4710(Color) \$77.68
#12 AN ShortKLUKRC-4712(Color) \$87.94

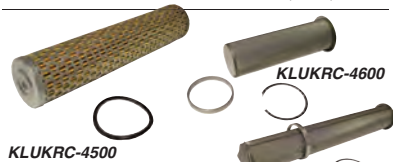

KLUKRC-4500

KLUKRC-4600

Elements



Long Paper ElementKLUKRC-4500\$8.92
Stainless Steel Element, 100 Mic Absolute ShortKLUKRC-4600\$26.99
LongKLUKRC-4602\$30.10



Fuel Filters

Inline Style Fuel Filter #8BRP5038\$49.19
Inline Style Fuel Filter #10BRP5039\$49.19
Also available in Black.

Inline Style Fuel Filter Replacement Filter

FRACG-27\$8.95



Filter Mounts for Inline Style Filters

1 1/4" Tubing MountBRP5034\$18.40
1 1/2" Tubing MountBRP5035\$18.40
1 3/4" Tubing MountBRP5036\$18.40
Also available in Black.



In-Line Aluminum Fuel Filters

Filter elements are 8" long and fit in a 9" housing. Overall length is 12" and outside dia is 2". Filter With 63 Micron Stainless Element And -10 Ends
ALL40219...\$65.99



Replacement Parts

In-Line Alum Fuel Filters

Replacement Parts For In-Line Alum Fuel Filters 10 Micron Paper Fuel Filter Element.
ALL40220...\$10.99

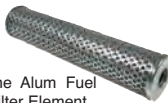

600 Series Filters

Peterson's 600 series filters provide the best filtering available. Features include anodized billet aluminum body and end caps for durability and resistance to fluid corrosion., stainless steel mesh screen and a pleated element for high flow.

Standard.....4.5" Long x 2" Diameter
Ball Valve5" Long x 2" Diameter

45 Micron Filter - Standard

-6 fittingsPET09-0610....\$135.48
-8 fittingsPET09-0611....\$135.48
-10 fittingsPET09-0612....\$135.48
-12 fittingsPET09-0613....\$135.48

45 Micron Filter - Ball Valve

-6 fittingsPET09-0600....\$174.73
-8 fittingsPET09-0601....\$174.73
-10 fittingsPET09-0602....\$174.73
-12 fittingsPET09-0603....\$174.73

60 Micron Filter - Standard

-6 fittingsPET09-0616....\$135.48
-8 fittingsPET09-0617....\$135.48
-10 fittingsPET09-0618....\$135.48
-12 fittingsPET09-0619....\$135.48

60 Micron Filter - Ball Valve

-6 fittingsPET09-0606....\$174.73
-8 fittingsPET09-0607....\$174.73
-10 fittingsPET09-0608....\$174.73
-12 fittingsPET09-0609....\$174.73

100 Micron Filter - Standard

-6 fittingsPET09-0620....\$135.48
-8 fittingsPET09-0621....\$135.48
-10 fittingsPET09-0622....\$135.48
-12 fittingsPET09-0623....\$135.48

100 Micron Filter - Ball Valve

-6 fittingsPET09-0624....\$174.73
-8 fittingsPET09-0625....\$174.73
-10 fittingsPET09-0626....\$174.73
-12 fittingsPET09-0627....\$174.73

Small Body - 600 Series Filter Mount Brackets

Fits 1-1/4" tube - 2 piecesPET09-0690...\$56.27
Fits 1-3/8" tube - 2 piecesPET09-0691...\$56.27
Fits 1-1/2" tube - 2 piecesPET09-0692...\$56.27
Fits 1-3/4" tube - 2 piecesPET09-0693...\$56.27
Firewall mount- 2 piecesPET09-0694...\$56.27

Fuel Filter Elements

600 Series Filters

45 Micron Gold/Red end caps.....PET09-0680\$38.50
60 Micron Gold/Black end caps.....PET09-0660\$38.50
100 Micron Gold/Purple end caps.....PET09-0699\$38.50

Rebuild Kits

The 600 series rebuild kit comes with all o-rings needed for the standard 600 series filter. Includes (2) o-rings for the endcaps and (1) element o-ring.

-8 thru -12 AN Filters (3) O-rings
For MethanolPET09-0689\$5.03
For VitonPET09-0686\$5.49
For UnleadedPET09-0688\$5.18

Throttle Linkage

Quick disconnect throttle linkage comes complete with carb bushings to hook up almost any carb. Aircraft alum is strong yet light-weight. Ends lock closed yet disconnect in seconds.
KLUKRC-1040...\$59.36



Inline Ball Valves

Made from aircraft alum, these valves utilize hardcoated alum balls and bodies along with Teflon seals. Make fuel or oil shutoff easy, while allowing full flow when opened.
-8 AN x -8 AN Small BodyPET09-0920...\$115.09
-8 push-on x -8 push-on Small BodyPET09-0922...\$115.09
-10 AN x -10 AN Large Body.....PET09-0940...\$121.16
-10 push-on x -10 push-on Large Body.PET09-0942...\$121.16



Throttle Cable Mounting Kit

Includes all necessary hardware to mount a Holley carb on a late model GM vehicle. Comes with a 1/8" blue anodized aluminum mounting plate and required clips, pivot, nuts and bolts to complete the job.
MOR65050\$46.41

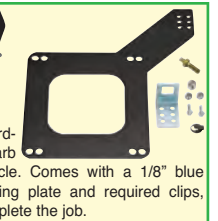

*Not legal for sale or use on pollution-controlled vehicles

Throttle Return Spring Kit

Manifold Mounted Chevy V6/V8

Provides positive throttle return required by several sanctioning bodies. Each kit fits Holley 2 or 4 bbl single carb applications.

18" SBC Cyl Heads, 5-7/16" TallMOR64922....\$22.00
SBC and 90" V6, 1-13/16" TallMOR64925....\$23.21
BBC, 1-13/16" Tall.....MOR64926....\$26.86
Tall Version to facilitate throttle return on spacer equipped SBC & 90" V6 engines, 4-3/4" Tall
MOR64928\$35.90



Carbureted Mounted 2300/4150 Series

The answer to your throttle return spring linkage problems if you're running a 2300/2305 series two-barrel or 4150/4160 series four-barrel Holley carb. Designed and built rugged enough for competition, yet it's polished chrome finish is suitable for the finest show car. Includes one set of heavy and one set of light springs.
MOR64927\$26.22



Carburetor Mounted 4500 Series

Made from sturdy 14-gauge steel and finished in hand-polished chrome. Kit includes heavy and light sets of stainless steel return springs, all mounting hardware.
MOR64923\$30.87



Throttle Return Spring Kits

4150 Holley Series Including HP Series

Made to clear low-profile racing air cleaners. Manufactured from sturdy 12-gauge steel and finished in (electrostatic paint) E-coat satin black.
MOR64919\$38.82

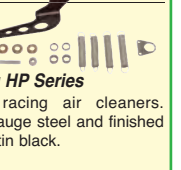

Throttle

Return Spring Kits

4500 Dominator and King Demon

Fits a 4500 series and King Demon carburetors. Made from sturdy 12-gauge steel & finished in (electrostatic paint) E-coat satin black.
MOR64918\$38.82

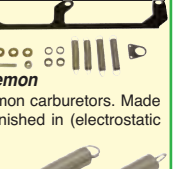

Throttle Return Springs

Pack of two stainless steel springs can be used as spares or replacements for Moroso Throttle Return Spring Kits.
MOR64929.....\$6.57



Carb Linkage Bushing Set Holley 4 bbl carbs

Steel linkage bushing set allows the fitting of a 1/4" fastener to the 1/2" dia. hole found in the throttle linkage plate of Holley 4 barrel carbs. Split bushing design permits simple installation and eliminates the sloppiness present when rubber bushings are used.
MOR64920.....\$5.89



In Line

Fuel Filters

ORB -10 ports. Fittings available to adapt these filters to AN -10, -08, and -06 line sizes. Size: 5.5" long x 2" dia.



High flow, 10-micron fabric (fine) replacement element. Flows 2,000 lb/hr a press drop of less than 1 PSI.
10 micron replacementAER12301\$105.00

High flow, 100-micron stainless steel (coarse) cleanable element. Flows 2,000 lb/hr a press drop of less than .5 PSI.
100 micron replacementAER12304\$129.40

Replacement Stainless Elements

10 micron stainless elementAER12601\$16.11
100 micron stainless elementAER12604\$40.91

Super Sonic Acoustical Mat

The ultimate acoustical control in an easy to install aluminum foil composite mat! Contains a high temperature adhesive backing.

12" x 12" (2)	THE14700	\$14.95
36" x 24"	THE14710	\$26.95
36" x 60"	THE14720	\$55.95
Mat Roller	THE14800	\$13.95



The Suppressor

Reduces road noise, rattles, engine noise, and any other noises that are bothersome. Also provides protection from radiant heat.

12" x 12" (2 pcs)	THE14600	\$13.95
12" x 33-1/2"	THE14600-12	\$220.95
36" x 24"	THE14610	\$25.95
36" x 60"	THE14620	\$51.95
36" x 33-1/2"	THE14620-36	\$343.95



Cool-It heat and sound insulating mat

Battles excessive heat and noise. Perfect for doors, under hoods and above transmission housings.

24" x 48"	THE14100	\$32.95
48" x 48"	THE14110	\$64.95
24" x 50 foot roll	THE14100-50	\$405.95



Thermo Guard FR

Absorbs sound and vibration. Provides protection from radiant heat. Available in two sizes.

48" x 72", 1 side foil	THE14120	\$43.95
48" x 72", 2 side foil	THE14125	\$61.95
24" x 48", 1 side foil	THE14130	\$23.50
Heavy Duty Spray Adhesive, 16 oz.	THE12005	\$12.95



Kevlar Heat Barrier

Various uses as a heat barrier. Can be used as a header blanket. Improves driver comfort and protects engine components. Reflects 90% of radiant heat, up to 3000 deg F. Size: 26" x 40".

THE16850

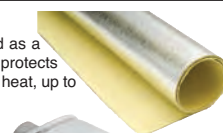

Kevlar Muffler Cover

Resists continuous direct contact with temperatures up to 1100 deg F. Includes all necessary fasteners. Uncut size is 26" X 40", trims easily with a strong sharp set of shears.

THE16800



Heavy-Duty Spray Adhesive Hi-Heat Coating

Perfect for heavy-duty applications. Fast-drying, quick-bonding, and high-temperature contact adhesive.

Black, 11 oz	THE12001	\$9.95
Aluminum, 11 oz	THE12002	\$9.95
Copper, 11 oz	THE12003	\$7.95
Clear, 11 oz	THE12004	\$8.95
Heavy-Duty Spray Adhesive, 16 oz.	THE12005	\$12.95



Flame Proof Paint

VHT FlameProof Coating will withstand temps up to 2000°F (1093°C) and is ideal for use on headers, exhaust systems, or wherever an extreme temp coating is needed. Temp: 1300°F-2000°F (704°C-1093°C)

Headers, Exhaust Manifolds, Piston Domes, Inside Heads
Flat Black VHTSP102

\$9.51



ARP Header Studs - 3/8" diameter

SBC	Hex	12-Point
Black Oxide	ARP100-1412..	\$51.48 ARP100-1402..\$60.78
Stainless 300	ARP400-1412..	\$65.20 ARP400-1402..\$114.74

BBC	Hex	12-Point
Black Oxide	ARP100-1413..	\$67.93 ARP100-1403..\$80.97
Stainless 300	ARP400-1413..	\$86.92 ARP400-1403..\$159.14

Header Bolts - 3/8" diameter

Small Black Chevy	Hex	12-Point
Black Oxide	ARP100-1101..	\$20.28 ARP100-1201..\$16.03
3/8" wrench	ARP100-1103..	\$23.90 ARP100-1203..\$25.11
drilled 3/8" wrench	ARP100-1103..	\$23.90 ARP100-1203..\$25.11

Stainless 300	Hex	12-Point
3/8" wrench	ARP400-1101..	\$21.81 ARP400-1201..\$21.81
drilled 3/8" wrench	ARP400-1103..	\$40.87 ARP400-1203..\$40.87

Big Block Chevy

Black Oxide	Hex	12-Point
3/8" wrench .750	ARP100-1102..	\$20.37 ARP100-1202..\$21.37
3/8" wrench 1.670	ARP100-1112..	\$27.43 ARP100-1212..\$28.52

Stainless 300	Hex	12-Point
3/8" wrench .750	ARP400-1102..	\$29.01 ARP400-1202..\$28.97
3/8" wrench 1.670	ARP400-1112..	\$44.08 ARP400-1212..\$46.64

Universal Exhaust Mount

It fits 5" or 6" muffler cans. Mounts to BRP 7100 rear nerf bar post. Clamp flips up or down and cradle spins front to back for infinite adjustment. Laser cut steel and powder coated. 2 springs included in kit to retain muffler to cradle. Replacement parts also sold separately. Cradle is BRP 9265 and clamp is BRP 9264. Bolts and seals for rear end are not included**

Exhaust Mt (Complete) ..BRP9263\$72.53

Alum. Exhaust ClampBRP9263A..\$24.55

Laser Cut Slotted BarBRP9263B ..\$8.93



Mounts for Low Slung Exhaust

Universal mount fits 5" muffler cans. Mounts on the BRP 7100 nerf bar post for hanging exhaust. Laser cut steel and black oxidized. Billet aluminum clamp and slotted steel strap make this fully adjustable for any position. Fits all brands of cars.

BRP9266.....\$54.69

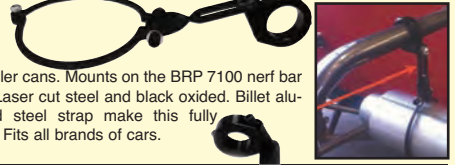

Rear Exhaust 3" Tailpipe Mount

Mounts to Rear Shock Slider Post (1-1/4") Universal with 2 Slotted Mounting Tabs Rubber Mounted in 2 Places for Vibration Resistance Comes Complete with All Hardware

BRP9324.....\$69.18



Measure. order. Install. Fully customizable exhaust mts.

Muffler and header combinations are ever changing. A standard "off the shelf" mount doesn't always cut it, but making one from scratch isn't any fun either. Enter the new "order what you need" kit. Pick between an 1-1/4" or 1-1/2" mounting clamp, pick the length of support link you need, grab one main saddle bracket, and then pick the size of the clamp you need from 3" up to 5". In most cases, its just what the Doctor ordered.

1-1/2" Chassis ClampBRP9470\$24.56

1-1/4" Chassis ClampBRP9471\$24.56

5" Support Link.....BRP9472\$12.24

7" Support Link.....BRP9473\$12.24

Main Saddle

(Clamp not included).....BRP9474\$27.84



Clamps

For 3" PipeBRPSFPHC19-325..\$25.27

For 3-1/2" PipeBRPSFPHC19-350..\$13.50

For 4" PipeBRPSFPHC19-425..\$13.50

For 4-1/2" PipeBRPSFPHC19-475..\$13.66



Header Tab Kit

Weld to headers to hold slip-on collectors in place or use to retain primary tubes on adjustable headers. Kit includes 2 pairs of tabs, two 1/4" bolts and two hex nuts. 2 tabs are recommended to secure each collector. Tabs are .085" thick, 2-1/2" long (when combined are 4" long) and 1" tall. Header Tab Kit, 2-Pack.

ALL60040

\$9.89



Crankcase Evacuation System

It reduces crankcase pressure throughout rpm range for increased piston ring seal, reduced intake charge contamination and fewer oil leaks. Includes breathers, grommets, one way valves and weld-in nipples.

Crankcase Evacuation System.....MOR25900\$68.57

Positive Locking Billet Alum Breather.....MOR68788\$102.86

Replacement Parts:

Oil Separator/Breathers.....MOR68780\$10.72

Check Valve for header collector.....MOR97800\$20.19

Weld-in Nipple for header collector.....MOR97810\$10.32



Insulating Header Wrap

Increases exhaust cycle efficiency; helps produce more horsepower with less fuel. Protects crew members from burns, and prevents starter wires and plug wires from coming into contact with hot header pipes. Reduces engine compartment temperature. Made from a silica-based formula that contains no asbestos.

2" x 1/16" x 100' roll ..MOR80807\$103.26

2" x 1/16" x 50' roll ..MOR80808\$57.40

1" x 1/16" x 50' roll ..MOR80809\$32.85



Heat Barrier Blanket

1/2" thick 18" x 24" non-asbestos blanket can be easily cut to any shape with scissors, and wrapped around fuel lines, brake lines, dry sump lines, power steering lines, etc; withstands up to 2300° F. May also be used on firewalls and floor boards to reduce in-car temperature.

MOR80805



Dirt Modified Headers

Forward design for muffler clearance. Fits Behrent, Bicknell, Olsen, TEO, Troyer & other chassis.

Small Block Chevy

Tube Dia.	Collector	Part #	Price
1 5/8"	3x8"	SCH1122B	\$249.95
1 5/8-1 3/4"	3x8"	SCH1122BV-3	\$299.95
1 5/8-1 3/4"	3 1/2x8"	SCH1122BV	\$299.95
1 3/4"	3x8"	SCH1124B-3	\$249.95
1 3/4"	3 1/2x8"	SCH1124B	\$249.95
1 3/4-1 7/8"	3 1/2x9"	SCH1124BV	\$309.95
1 5/8-1 3/4"	3x8"	SCH1122BV-3	\$299.95



SBC 358 DIRT

1 3/4-1 7/8"	3 1/2x9"	SCH1124BV	\$309.95
1-5/8"	3"x8"	SCH1122BVSH-3	\$299.95
1-5/8"	-1-3/4" 3"x8"	Upswept SCH1122BVUSH-3	\$299.95

Big Block Chevy

2"	3 1/2x9"	SCH2123	\$269.95
----	----------	---------	----------

602 Crate Motor Up Swept

1 5/8"	3x8"	SCH1122BU2	\$249.95
--------	------	------------	----------

Spec Head 358 DIRT

1 5/8"-1-3/4"	3x8"	SCH1122BVSH-3	\$299.95
---------------	------	---------------	----------



Crate Late Model Headers

GRT, Stinger, TNT, American Made, Barry Wright, Bullitt, Fegers, Larry Shaw, Raider, & Rayburn.

Tube Diam.	Collector	Part #	Price
1 5/8"-1 3/4"	3"	SCH1141-605LVGCM-3	\$299.95

Fits Rocket Chassis

1 5/8"-1 3/4"	3"	SCH141-525LVCM-3	\$299.95
---------------	----	------------------	----------



Street Stock Headers

Camaro 70-81, Chevelle, Monte 64-77. Stock location or set back. Will not fit angle plug heads.

Tube Diam.	Collector	Part #	Price
1 5/8"	3x8"	SCH165	\$179.95
1 5/8-1 3/4"	3x8"	SCH165V	\$229.95
1 3/4"	3 1/2x8"	SCH166	\$179.95

Camaro 70-81, Monte, Grand Prix, Cutlass, Regal 78-86. Fits angle plug heads. Will not clear stock clutch linkage ball.

1 5/8"	3x8"	SCH185	\$179.95
1 5/8-1 3/4"	3x8"	SCH185V	\$229.95
1 3/4"	3 1/2x8"	SCH186	\$179.95



Dirt Late Model Tri-Y Headers

4 into 2 into 1 Tube Configuration for Increased Torque. Fits Masterbilt, Rocket, & most other chassis.

Tube Diameter	Coll. Dia.	Part #	Price
1 3/4" - 1 7/8"	3 1/2"	Std Chevy SCH14260LVY	\$709.95
1 3/4" - 1 7/8"	3 1/2"	Spread Port SCH14260LVYSP	\$759.95
1 3/4" - 1 7/8"	3 1/2"	13", 15", 16" Chevy 18" SCH14260LVY18	\$759.95

- 4 into 2 into 1 Tube Configuration for Increased Torque.
- Fits Masterbilt, Rocket, and most other chassis.



4-7 Cam Swap

Tube Diameter	Coll. Dia.	Part #	Price
1 3/4" - 1 7/8"	3 1/2"	Std Chevy SCH14267LVY	\$709.95
1 3/4" - 1 7/8"	3 1/2"	Spread Port SCH14267LVYSP	\$759.95
1 3/4" - 1 7/8"	3 1/2"	13", 15", 16" Chevy 18" SCH14267LVY18	\$759.95



Exhaust Universal Mufflers

Length	Outlet Dia	Inlet Dia	Body Dia	Part #	Price
6"	3"	3"	3 1/2"	SCH63030	\$15.95
6"	3 1/2"	3 1/2"	4"	SCH63535	\$15.95
8"	3"	3"	3 1/2"	SCH83535	\$15.95
8"	3 1/2"	3 1/2"	4"	SCH83535	\$15.95
9"	3 1/2"	3 1/2"	4 3/8"	SCH92535	\$35.95
10"	3 1/2"	3 1/2"	4"	SCH103535K	\$35.95
12"	3"	3"	3 1/2"	SCH123030	\$22.95
12"	3 1/2"	3 1/2"	4"	SCH123535	\$26.95
18"	3 1/2"	3 1/2"	4"	SCH183535	\$30.95

More sizes available!



IMCA Legal Slip in Mufflers

Fits 3" and 3 1/2" collectors. Removes 9dB

6" Long	SCHIMCA609	\$38.04
3"	SCHIMCA930	\$35.95
3 1/2"	SCHIMCA935	\$35.95

Universal Mufflers

Fits 3 1/2" collectors. 8" to 24" lengths



IMCA Headers

SBC • Adjustable

Tube diam.	Coll.	Angle	Part #	Price
1 5/8-1 3/4"	3x8"	45°-90°	SCH161-68	\$179.95
1 5/8-1 3/4"	3x8"	90°-90°	SCH161-98	\$179.95
1 3/4-1 7/8"	3.5x8"	45°-90°	SCH162-68	\$229.95
1 3/4-1 7/8"	3.5x8"	90°-90°	SCH162-98	\$229.95



Exhaust Turnouts

3" Turnout	SCH3025	\$18.95
3 1/2" Turnout	SCH3525	\$18.95

Straight Tubing

3" x 36"	SCH360030	\$15.95
3 1/2" x 36"	SCH360035	\$16.95
4" x 36"	SCH360040	\$26.95

Elbows

2-1/2"	45°	SCH2545	\$23.95
2-1/2"	90°	SCH2590	\$23.95
3"	13°	SCH3013	\$23.95
3"	30°	SCH3031	\$23.95
3"	30° long	SCH3032	\$23.95
3"	45°	SCH3045	\$23.95
3"	90°	SCH3090	\$23.95
3-1/2"	13°	SCH3513	\$23.95
3-1/2"	30°	SCH3531	\$23.95
3-1/2"	30° long	SCH3532	\$23.95
3-1/2"	45°	SCH3545	\$23.95
3-1/2"	90°	SCH3590	\$23.95

Reducers

2 1/2" x 3"	SCH2530	\$7.95
2 1/2" x 3 1/2"	SCH2535	\$9.95
3" x 3 1/2"	SCH3530	\$8.95
3 1/2" x 3 1/2"	SCH3535	\$8.95
4" x 3 1/2"	SCH4035	\$9.95



Header Gaskets

Perforated Steel Core w/anti-stick coating.

SBC small race port 1.5"x1.5"	FEL1404	\$16.38
SBC large race port 1.55"x1.55"	FEL1405	\$22.59
SBC D-port	FEL1406	\$20.69
SBC spread port	FEL1409	\$21.81
BBC small race round 1.94"	FEL1411	\$22.94
BBC large race round 2.13"	FEL1412	\$21.65

Adapter Plates

Adapts Stahl Pattern big tube headers to standard SBC bolt pattern heads.

Aluminum	SCH0101K	\$124.95 pr.
----------	----------	--------------

Crate Motor Gaskets

Tube Dia.: 1-5/8" or 1-3/4"	SCH01560	\$8.00
For 602 Crate Motor	SCH01562	\$8.00

Spiral Muffler

Spiral baffles specially tuned for high velocity gas flow. Continuous welds ensure leak-free sealing. 4" dia. x 12" long.

2.5" in & out	MOR94050	
3" in & out	MOR94051	
3.5" in & out	MOR94052	\$69.00

BSC90175



SBC	BSC90175	\$16.99
BBC	BSC90176	\$16.99

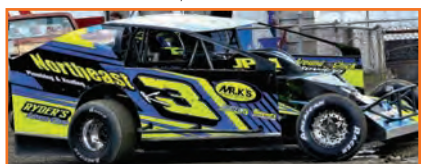



Northeast Dirt Modified (4-1 Headers)

Big Block Standard Header (BB 4-1 Header)

28" - 2" Tube 3-1/2" Collector.....	BEYNEDMBB2-28.....	\$360.00
36" - 2" Tube 3-1/2" Collector.....	BEYNEDMBB2-36.....	\$360.00
28" - 2-2-1/8" Tube 3-1/2" Collector.....	BEYNEDMBB-S428.....	\$360.00
36" - 2-2-1/8" Tube 3-1/2" Collector.....	BEYNEDMBB-S436.....	\$360.00

Small Block Header (SB 4-1 Header)

1-5/8" x 1-7/8" 28" Tube Length 3-1/2" Collector ..	BEYNEDMSB28-S1.....	\$340.00
1-3/4" x 1-7/8" 36" Tube Length 3-1/2" Collector ..	BEYNEDMSB36-S2.....	\$340.00
4-1 602 Header 1-5/8" x 1-3/4" x 3"	BEYNEDMSB-602.....	\$340.00
4-1 604 Header 1-5/8" x 1-3/4" x 3"	BEYNEDMSB-604.....	\$340.00
602 Crate Straight Tube Header 1-5/8" x 3"	BEYNEDMSB-602-10.....	\$480.00
525 Crate Motor Header 1-3/4" x 3"	BEYNEDMSB-525-S1.....	\$380.00
Small Block 4-1 Header 1-3/4" x 1-7/8" 3.5" Coll.	BEYNEDMSB-T2.....	\$340.00
358 - Upswept, 1 5/8" x 1 3/4" x 3", Dirt Spec	BEYNEDMSBUS-S1-DL.....	\$340.00



Northeast Dirt Modified (Tri-Y Headers)

Big Block Tri-Y Headers Upswept

2" x 2-1/8" x 3"	BEYNEDMBBTYUS-S4.....	\$850.00
2" x 2-1/8" x 3" w/ Side Oil Tank	BEYNEDMBBTYUS-S4-SOT.....	\$850.00
1-7/8" x 2-1/8" x 3"	BEYNEDMBBTYUS-D3.....	\$850.00
1-7/8" x 2-1/8" x 3" w/ Side Oil Tank	BEYNEDMBBTYUS-D3-SOT.....	\$850.00

Small Block Tri-Y Upswept Headers

1-5/8" x 1-7/8" x 3" Col Header Upswept.....	BEYNEDMSBTYUS-D1-3.....	\$780.00
1-5/8" x 1-7/8" x 3.5" Col Header Upswept.....	BEYNEDMSBTYUS-D1-35.....	\$780.00
1-5/8" x 1-7/8" x 3" Col Header Upswept.....	BEYNEDMSBTYUS-D2-3.....	\$780.00
1-5/8" x 1-7/8" x 3.5" Col Header Upswept.....	BEYNEDMSBTYUS-D2-35.....	\$780.00
1-3/4" x 1-7/8" x 3" Col Header Upswept.....	BEYNEDMSBTYUS-S2-3.....	\$780.00
1-3/4" x 1-7/8" x 3.5" Col Header Upswept.....	BEYNEDMSBTYUS-S2-35.....	\$780.00
1-7/8" x 2" x 3.5" Col Header Upswept.....	BEYNEDMSBTYUS-S3-35.....	\$780.00
1-5/8" x 1-7/8" x 3" 525 Crate Motor....	BEYNEDMSBTYUS-525D1-3 TRI-Y.....	\$779.93



Dirt Sprint Tri-Y Headers

Dirt Sprint Car Tri-Y Sprint 1-3/4" x 1-7/8" x 3"	BEYDSTY23S2.....	\$720.00
Dirt Sprint Car Tri-Y Sprint 1-3/4" x 2" x 3"	BEYDSTYSP360D2.....	\$760.00

305 Dirt Sprint Car Headers

DIRT Sprint Car Tri-Y Sprint 1-3/4" x 1-7/8" x 3"	BEYDSTY23S2.....	\$720.00
8" Second Stage with 3" x 12" Collector	BEYDSTY23S2.....	\$720.00

Dirt Late Model Crate 602-604

Dirt Late Model 4-1 602/604 Crate	BEYDLM604-17.....	\$640.01
---	-------------------	----------

602 Northeast Crate Dirt Modified Headers

DIRT Approved	BEYNEDMUS602-DL.....	\$280.00
---------------------	----------------------	----------

Northeast 602 Sportsman Kit

Dirt Modified Upswept Tail Pipe Kit for	BEYNEEDMTPKUS602-BEY.....	\$120.00
---	---------------------------	----------

Dirt Mod Upswept

602 Sportsman Kit for 2019 Assembled &	BEYNEDMTPKUS602-19A.....	\$400.00
Painted 2-Adaptors 2-3"-15 Tailpipes 2-MUF3DL	BEYNEDMTPKUS602-19.....	\$135.00

North East Dirt Modified Upswept

602 Sportsman Kit for '19 Unassembled 2-Adaptors 2-13" Tailpipes	BEYNEDMTPKUS602-19.....	\$135.00
--	-------------------------	----------

Header Bolts MOROSO

38" -16 x 3/4" hex head bolts for SBC, BBC & 90" V6 Chevy	MOR38710.....	\$10.19
---	---------------	---------

Header Gaskets

A.) Small Port.....	BEYHG23SP	\$16.00
B.) Fast Burn 604.....	BEYHG604.....	\$20.00
C.) SBC 23".....	BEYHG23.....	\$20.00
D.) SBC 23" Dart Platinum.....	BEYHG23DP.....	\$22.00
E.) 11x Spreadport 18 Brodix.....	BEYHG18B.....	\$22.00
F.) 18" Chevy.....	BEYHG18C.....	\$22.00
G.) 13" All Pro.....	BEYHG13AP.....	\$22.00
H.) Gasket	BEYHG913.....	\$22.00
I.) Big Block.....	BEYHGBBC.....	\$20.00
J.) Ford Yates D3/SC1.....	BEYHGFDD3.....	\$26.00



Northeast Dirt Modified DIRT 358 Spec Headers

Small Block Upswept 1-5/8" x 1-3/4" 3 Dirt Spec Header	BEYNEDMSBUS-S1-DL.....	\$340.00
--	------------------------	----------

Northeast 358 Modified Spec Kit

Dirt Modified Upswept Tail Pipe Kit for 3"-3.5" Extension,	BEYNEDMTPKUS3-3.5-BEY.....	\$140.00
--	----------------------------	----------

Dirt Legal 3.5" Mufflers

3.5" x 8" x 3.5" Dirt Modified Muffler	BEYMU35DL.....	\$105.00
--	----------------	----------

Mufflers - Dirt Late Model

& IMCA Modified

2.5" x 2.5" 6" Body	BEYMU2.5.....	\$48.00
2.75" x 2.75" 6" Body.....	BEYMU2.75.....	\$45.00
3" x 3" 6" Body.....	BEYMU3.....	\$45.00
3.5" x 3.5" 6" Body.....	BEYMU3.5.....	\$49.98
Dirt Late Model Crate Muffler	BEYMU2.75-17.....	\$45.00



Mufflers

North East Dirt Modified

Dirt Modified Muffler 2.5" x 2.5"; 8" Body.....	BEYMU2.5DM	\$85.00
Dirt Modified Muffler 3" in, 3" out; 8" Body.....	BEYMU3DM	\$85.00
Dirt Modified Muffler 3" in, 3" out; 8" Body - Dirt Legal.....	BEYMU3DL	\$100.00
Dirt Modified Muffler 3.5" x 3.5"; 8" Body.....	BEYMU35DM	\$100.00
Dirt Modified Muffler 3.5" x 3.5"; 8" Body - Dirt Legal.....	BEYMU35DL	\$105.00

Pro Stock Muffler 2.5" in, 2.5" out; 8" Body - Dirt Legal	BEYMU25DL	\$99.99
---	-----------------	---------

Tail Pipe Kits - Northeast Dirt Modified SB & BB

Dirt Modified Upswept 3" Tailpipe Kit 15 Degree

BEYNEEDMTPK-3US	\$86.00
-----------------------	---------

Dirt Modified Upswept 3.5" Tailpipe Kit 15 Degree

BEYNEEDMTPKUS35	\$90.00
-----------------------	---------

Dirt Modified Upswept Tailpipe Kit for Side Oil Tank. Kit includes: 3" SOT Elbow,

1) 3.5 30 degree Tailpipe & 1) 3.5 15 degree tail pipe	BEYNEEDMTPKUS3-3.5-BEY.....	\$140.00
--	-----------------------------	----------

Dirt Modified 3.5" Upswept Tailpipe Kit for Side Oil Tank

BEYNEEDMTPKUS-3.5-SOT	\$128.00
-----------------------------	----------



W16 Header and Kit

North East Dirt Modified W16 Engine Single

Step 1 3/4 - 1 7/8 - 3.5" Collector

BEYNEDMSBTY-LS-S2-3.5	\$700.00
-----------------------------	----------

North East Dirt Modified W16 Exhaust kit

BEYNEEDMTPK-W16.....	\$140.00
----------------------	----------

Dirt Modified 3" Dirt Legal Muffler 3" x 8" x 3"

BEYMU3DL.....	\$100.00
---------------	----------



Header Bolts

3/8-16 x 3/4" - 12 per Package, Grade-5,	MRG915	\$7.72
--	--------------	--------

Header Allen Bolts

These are high quality steel bolts, that have a black oxide coating to resist rust and work well where space is minimal (like in most header applications), the smaller allen head allows you to get that smaller allen wrench on the bolt to tighten it. Made From Grade 8 Steel. They Have A Black Oxide Coating. They Have A Allen Head. 12 EA Per Set.

MRG916	\$14.38
--------------	---------

Tailpipe Header Bolts

for Northeast 602 Sportsman Tailpipe Kit

These are high quality bolts that are proven performers. They have a black oxide coating that resists rust. Fits: AMC 290-401 SBC 262-400 BB Chrysler 383-440 (Doesn't Fit 426 Hemi) Pontiac 326-455 Oldsmobile 330-455. Has A Black Oxide Coating. Made Of High Quality Grade 8 Steel. Have A Hex Head w/Flange. Design for Minimal Clearance Apps. 12 per Pkg.

MRG917	\$12.17
--------------	---------

Headlock Locking Header Bolts

Fits AMC 290-401. SBC 262-400, BB Chrysler 383-440 (Does not Fit 426 Hemi), Pontiac 326-455, and Oldsmobile 330-455

MRG2230G	\$32.25
----------------	---------

Header Bolt Lock Washers

This is a good addition to your header installation. These washers will help to prevent loosening caused by vibration, and they also help maintain fastener clamp load for positive flange seal. These Washers Have A Black Oxide Coating. They Have 12 In A Set.

MRG3416	\$9.93
---------------	--------

Header Bolts

Good looking black header bolts that works very well on header applications where space is minimal. This bolt also has both socket and allen head configuration which allows for ease of installation. Fits: AMC 290-401 SBC 262-400 BB Chrysler 383-440 (Does not Fit 426 Hemi) Pontiac 326-455 Oldsmobile 330-455. Made From High Strength Steel. Corrosion Resistant Black Coating. Has Both Socket And Hex Heads For Ease Of Use. 12 per Package

MRG3420G	\$14.38
----------------	---------

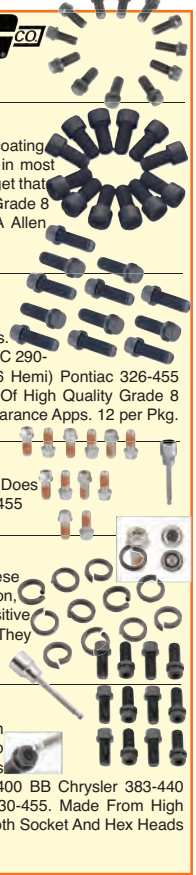

Exhaust Insulating Wrap

Increase horsepower and efficiency, and reduce underhood temperatures up to 70%.

1" x 15'THE11151\$8.95
 1" x 50'THE11001\$25.95
 2" x 15'THE11152\$13.95
 2" x 50'THE11002\$42.95
 2" x 25'THE11002-25\$22.95
 2" x 100'THE11003\$85.95
 6" x 100'THE11006\$201.95



Graphite Black Exhaust Insulating Wrap

The original exhaust insulating header wrap comes in two colors. Withstands continuous heat up to 2000 degrees farenheight.

1" X 50'THE11021\$28.95
 2" X 50'THE11022\$45.95
 2" X 25'THE11023\$45.95
 2" X 100'THE11023\$88.95
 1" X 15'THE11153\$9.95
 2" X 15'THE11154\$14.95



Generation II Copper Exhaust Insulating Wrap

Improves heat resistance up to 20% more than current technology, by utilizing a new proprietary coating developed by Thermo-Tec.

1" X 50'THE11031\$28.95
 2" X 50'THE11032\$47.95

Hi Heating Coating, Copper
 THE12003\$7.95



High Velocity Exhaust Jackets

Can be installed with the headers mounted. Reduces underhood temps up to 70%

4-6 Cyl Kit...THE11246...\$65.95
 8 Cyl Kit.....THE11248...\$86.95



Clamp-On Heat Shield

For exhaust pipes. Installs in minutes using supplied clamps and new stand offs. Blocks over 95% of radiant heat of the exhaust.

1'.....THE11600.....\$23.95
 2'.....THE11620.....\$35.95
 3'.....THE11630.....\$47.95
 4" x 1'.....THE11650.....\$25.95
 4" x 2'.....THE11660.....\$47.95



Header Manifold Blanket

Clips into place on the upper portion of the headers. Protects from heat & spills.

(2) 20" by 24" blankets for V6 and V8 applications, and (1) 36" by 40" blanket for straight 6 and 4 cylinder engines.

(2) 20" X 24" Blankets.....THE14003.....\$81.95
 (1) 36" X 40" Blankets.....THE14004.....\$76.95



Turbo Insulating Kit

Will reduce turbo lag and increase performance. Comes in a cut-to-fit kit.

4 Cylinder Kit.....THE15001...\$91.95
 6 and 8 Cylinder Kit.....THE15002...\$106.95
 Turbo Insulating Cover Only ..THE15003...\$31.95



Snap Strap Kit

Easily secures the exhaust insulating wrap with no tools needed. Made of high temperature stainless steel. New precut lengths with a tough multi-lock system.

V-8 Kit 8-9" Strap x 4-18" StrapTHE13101...\$28.95
 V-8 Kit 4-9" Strap x 2-18" StrapTHE13102...\$15.95
 V-6 Kit 6-9" Strap x 4-18" StrapTHE13105...\$24.95
 V-6 Kit 6-9" Strap x 4-18" StrapTHE13150...\$25.95
 6-Pack 18" x 6-18" Strap.....THE13160.....\$16.95



Cool Fuel Jug Cover

The highly reflective surface reflects radiant heat, solar radiation and harmful UV rays. Protect your fuel at the track, in the truck and in the shop with this Cover, which can reduce fuel temps by as much as 20° F.

Square 5 gallon cover.....THE14175...\$21.95
 Round 5 gallon cover.....\$21.95



Battery Wrap Heat Barrier

Adhesive backed heat barrier that absorbs battery acid and protects from radiant heat up to 2000° F.

THE13200.....\$25.95



Express Sleeves

Highly reflective mylar foil with a Velcro closure to provide max protection.

3 ft x 1".....THE14030.....\$22.95
 12 ft x 1".....THE14031.....\$89.95
 3 ft x 1-1/2".....THE14035.....\$26.95
 12 ft x 1-1/2".....THE14036.....\$104.95
 50 ft x 1-1/2".....THE14035-50 \$435.95



Thermo-Sleeve seamless heat sleeve

Laminated high-temp aluminized fabric sleeves to protect your wires and hoses.

3 ft 1/4" to 1/2".....THE14005.....\$11.95
 50 ft 1/4" to 1/2".....THE14005-50...\$199.95
 3 ft 5/8" to 1".....THE14010.....\$15.95
 50 ft 5/8" to 1".....THE14010-50...\$265.95
 3 ft 1-1/8" to 1-1/2".....THE14015.....\$19.95
 3 ft 1-5/8" to 2".....THE14020.....\$23.95
 50 ft 1-5/8" to 2".....THE14020-50...\$398.95
 3 ft 2-1/8" to 2-1/2".....THE14025.....\$27.95
 50 ft 2-1/8" to 2-1/2".....THE14025-50...\$464.95
 12 ft 1/4" to 1/2".....THE14006.....\$47.95
 12 ft 5/8" to 1".....THE14011.....\$63.95
 12 ft 1-1/8" to 1-1/2".....THE14016.....\$79.95
 12 ft 1-5/8" to 2".....THE14021.....\$95.95
 12 ft 2-1/8" to 2-1/2".....THE14026.....\$111.95



Starter Heat Shield

7" x 22". Insulates the starter and solenoid from radiant heat. Installs using snap straps.

THE14150.....\$24.95



Spark Plug Shield

Ultimate protection for your spark plug wires. Reflects radiant heat up to 2000 degrees farenheight.

6" x 1-1/2" (2).....THE14200.....\$15.95
 6" x 1-1/2" (4).....THE14250.....\$31.95



Cool-It Plug Wire Sleeves

Keeps the spark plug and ignition wire cool while extending its life. Comes in five colors and packs of 4 and 6.



Natural, 4 packTHE14260...\$29.95
 Red, 4 packTHE14261...\$29.95
 Black, 4 packTHE14262...\$29.95
 Black, 4 packTHE14263...\$29.95
 Silver, 6 packTHE14270...\$44.95
 Red, 6 packTHE14271...\$44.95
 Black, 6 packTHE14272...\$44.95
 Blue, 6 packTHE14273...\$44.95



Cool-Air Tube Heat Shield

3 ft adjustable dia shield. The unique lace up tube cover design allows these heat shields to fit from 2.5" to 4" air tubes up to 36" long. The lace on heat shield blocks over 98% of the radiant heat of the turbo and exhaust.

THE14500.....\$47.95

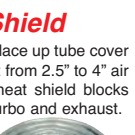

Heat Sleeves

Protective barrier for extreme heat exposure. Excellent thermal and abrasion resistance.

1/2" x 3 foot black...THE18050...\$22.95
 3/4" x 3 foot black...THE18075...\$28.95
 1" x 3 foot black...THE18100...\$38.95
 1/2" x 3 foot silver...THE18051...\$22.95
 3/4" x 3 foot silver...THE18076...\$28.95
 1" x 3 foot silver...THE18101...\$38.95
Also available in 10 ft & 50 ft lengths.



Ignition/Plug Wire Slewing

Highly flexible and abrasion resistant, they offer max protection against spark loss. The inside is braided continuous e-glass insulation good up to 1000°F. The silicone outer surface is good for temps up to 500°F.

3/8" x 25', BlackTHE14040\$55.95
 3/8" x 25', BlueTHE14045\$55.95



Thermo-Flex

Flexible protection for hoses and wiring. Can be slit for easy installation over existing wires.



5/8" x 10 ft silverTHE17062-10....\$42.95
 3/4" x 10 ft silverTHE17075-10....\$47.95
 1" x 10 ft silverTHE17100-10....\$55.95
 1-1/4" x 10 ft silverTHE17125-10....\$61.95
 1-1/2" x 10 ft silverTHE17150-10....\$70.95
 3" x 10 ft silverTHE17300-10....\$114.95
 5/8" x 3 ft silverTHE17062.....\$12.95
 3/4" x 3 ft silverTHE17075.....\$14.95
 1" x 3 ft silverTHE17100.....\$16.95
 1-1/4" x 3 ft silverTHE17125.....\$18.95
 1-1/2" x 3 ft silverTHE17150.....\$21.95
 3" x 3 ft silverTHE17300.....\$34.95
 5/8" x 3 ft blackTHE17063.....\$14.95
 3/4" x 3 ft blackTHE17076.....\$16.95
 1" x 3 ft blackTHE17101.....\$19.95

Adhesive Backed Heat Barrier

It is made up of woven silica with a flexible aluminized finish. The highly reflective surface of the material is capable of withstanding radiant temp in excess of 2000°F.

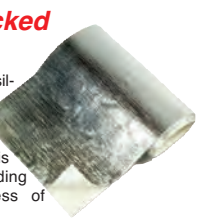

THE1350012" X 12"\$10.95
 THE1357512" X 24"\$18.95
 THE1358524" X 36"\$50.95
 THE1359024" X 48"\$67.95
 THE13575-5012" X 50 ft.....\$474.95
 THE13590-5024" X 50 ft.....\$844.95

Aluminum Heat Barrier

Multipurpose radiant heat protection up to 2000 degrees farenheight.

THE1400136" X 40"\$79.95
 THE14001-50.....50" X 40"\$1330.95
 THE1405136" X 20"\$41.95
 THE1406118" X 20"\$21.95



24 K Heat Barrier

It helps protect vital engine components and provides a barrier against radiant heat up to 2000°F. Helps lower intake and under.

THE1370012 in. x 24 in.\$25.95
 THE1377524 in. x 24 in.\$50.95

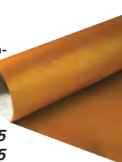

Thermo-Shield Self Adhesive Wrap

Aluminized adhesive backed tape for protecting wires, hoses or any wrapable part. **NOT FOR USE ON EXHAUST.**

1-1/2" x 15 ft.....THE14002.....\$15.95
 2" x 50 ftTHE13995.....\$42.95



Muffler/Cat Heat Shield

Highly flexible, very versatile MYLAR heat shield. Protects undercarriage from the radiant heat off an exhaust system.

24" x 40" Mylar.....THE16500.....\$59.95



Competition Floor Insulating Mat

Highest quality materials using Thermal Conductive technology to protect the driver from excessive radiant heat.

8" x 12"THE16510\$61.95
 10" x 18"THE16520\$87.95
 18" x 18"THE16530\$106.95
 18" x 24"THE16540\$112.95
 24" x 24"THE16550\$120.95
 24" x 26"THE16560\$128.95



Polished Timing Cover

Polished die-cast alum w/allen-type bolts around the edge. Seals, gaskets, and washers included.

One-Piece.....EDE4240.....SBC V8\$57.55
 One-Piece.....EDE4241.....BBC V8\$79.95
 Two-Piece.....EDE4242.....SBC V8\$114.05



POWERFORCE+PLUS SFI Spec. Racing Harmonic Dampers

They are all tested to SFI specification #18-1 and are certified to meet that spec. Each damper includes a special card w/an official SFI #18-1 sticker affixed to it.

6-3/4" Damper for 350 Chevy V8 (Int)
 PRF90000.....\$144.25
 6-3/4" Damper for 400 Chevy V8 (Ext)
 PRF90001.....\$159.20
 8" Damper for 350 Chevy V8 (Int)
 PRF90002.....\$168.30
 8" Damper for 400 Chevy V8 (Ext)
 PRF90003.....\$174.30

POWERFORCE Perf. Street Dampers

Extremely tough nodular iron suitable for perf street and mild racing applications. Quality semi-gloss black paint finish. Timing marks in easily viewed white markings. Bolt-in counterweights. Non-SFI.

Not recommended for circle track use!

PRF80010 6" SBC lightweight.....\$62.30
 PRF80000 6 3/4" 350 SBC.....\$51.30
 PRF80001 6 3/4" 400 SBC.....\$62.30
 PRF80004 8" 396/427 BBC.....\$84.02
 PRF80005 8" 454/502 BBC.....\$91.98
 PRF80006 6.4" early SBF (28.4 oz).....\$84.02
 PRF80007 6.4" late SBF (50oz).....\$84.91

Harmonic Balancer Bolt Kits

They developed these ultra strong 200,000 psi bolts that let you exert max clamping force. Features include 1/4" thick, wide area washer & an extra tall 12-point head that accepts a deep socket.

SBC Dia/Thread Size: 7/16-20 • UHL: 2.470
 Socket Size 5/8.....ARP134-2501.....\$25.91
 Socket Size 13/16.....ARP234-2501.....\$30.23

BBC Dia/Thread Size: 1/2-20 • UHL: 1.550
 Socket Size 5/8.....ARP135-2501.....\$25.83
 Socket Size 13/16.....ARP235-2501.....\$30.17
 Socket Size 1-1/16.....ARP235-2502.....\$32.10

Ford 289-460 cid (except 351C)
 Dia/Thread Size: 5/8-18 • UHL: 2.050
 Socket Size 5/8.....ARP150-2501.....\$25.16

Distributor Stud Kits

ARP offers these premium grade studs, which are equipped with vibration-resistant J-form threads, in your choice of black oxide finished chrome moly or rust-proof stainless steel. Washers included.

Chevy
 Black Oxide 12- Point.....ARP130-1701...\$4.60
 Stainless 300 12- Point.....ARP430-1701...\$10.62

Performer-Link Timing Chain

It has solid bushing design to eliminate chain stretch. Like all good timing chains, they have 3 keyway settings (normal, 4° advance, 4° retard) for specific timing selections.

EDE7800'55-94 Chevy 262-400 V8.....\$47.35
 EDE7808'63-76 Ford 366-428.....\$60.75
 EDE7810'65-94 Chevy 396-454.....\$55.45
 EDE7811'62-65/'73-95 Ford 221-351W.....\$56.45
 EDE7814*'62-65/'73-95 Ford 221-351W.....\$33.65
 EDE7820'65-721/2 Small Ford.....\$51.45
 EDE7821'62-80 Ford 351C, 351M & 400...\$61.85
 EDE7803'56-90 Chrysler 273-360 & 392...\$70.35

MANLEY Race Roller Timing Kits

Billet cam gear, 3 keyway crank gear.
 SBC w/brass shim.....MAN73111...\$97.57
 SBC w/torrington bearing...MAN73121...\$105.17

Race Roller with torrington bearings and roller thrust button, 3 keyway crank gear.

SBC -'55 to '78.....MAN73141...\$96.33
 BBC.....MAN73142...\$106.06

"Rattler" Harmonic Balancer

More than a crank damper, the Rattler is a Torsional Vibration Absorber. No fluids or elastomers to leak or wear out. Engraved timing marks cannot move in relation to the crank.

SBC 6.290" 7 lbs. 8oz.TCI870001.....\$329.18
 SBC 7.170" 10 lbs. 6oz.....TCI870002.....\$372.40



BBC Harmonic Balancer Bolt & Washer Sets 396-454

This is a high quality bolt set designed for that big block Chevy balancer, this bolt works well on either, OE applications or any type of racing where a high quality bolt is needed. These Are Have A Zinc Dichromate Finish. Tall Hex Head Bolt To Prevent Slippage. Extra Thick Parallel Ground Washer. Washers Provides More Accurate And Uniform Torque. Grade 8 Alloy Steel.
 MRG946G.....\$17.70

MSD Timing Tapes for Harmonic Balancers

It comes with eight different tapes to fit common balancers ranging from 5.25" to 8" in dia. The tapes are marked off in one degree increments from 14° ATDC to 64° BTDC and are printed on a tough, chemical resistant material. Not only do the MSD Timing Tapes help you get an exact timing setting, they allow you to see exactly where the Total timing is set.
 MSD8985.....\$4.83

ARP Square Drive Balancer Bolts

ARP offers a special version of its rugged 200,000 psi rated balancer bolt that can accept a standard 1/2" drive ratchet or breaker bar to facilitate rotating the crank assembly.
 • 1/2" square drive forged into bolt head, enabling the rotation of an engine with any 1/2" drive tool
 • Made from heat-treated 8740 chrome moly steel with heavy duty black oxide finish
 SBC.....ARP134-2503.....\$39.17
 BBC.....ARP135-2503.....\$39.17



Billet Aluminum Timing Cover

This CNC machined 2 pc. timing cover lets you adjust cam timing without breaking oil pan seal. Includes all hardware.
 COM210.....\$282.58

Steel Timing Cover

Don't be fooled by the stock appearance of this OEM style cover. Made from heavy gauge steel, it features built in cam button reinforcing, thrust bearing and all hardware. USA made. A very nice piece.
 COM208.....\$123.42

Magnum Timing Gear Set

Industry's most reliable. Pre-stretched and heat treated. Double roller design. Dynamically balanced.
 SBC ...COM2100.....\$28.39
 BBC ...COM2110.....\$38.88

Timing Gear Drive

SBC ...COM4100.....\$207.02
 BBC ...COM4110.....\$268.34

Timing Belt Set

Adjustable timing with vernier sprocket. Idler pulley.

SBC ...COM6500...\$1117.95
 BBC ...COM6200...\$1072.15

Hi-Tech Roller Race Sets

Double Roller Chain, Triple Index Gear, Designed for Extreme Racing, Oversized Rollers, Dynamically Balanced

Chevy V8, 265-400, '55-91 (except w/factory roller cam)
 COM3100.....\$49.61

SBC True Roller Race Set .005 undersized, For align bored blocks
 COM3100-5.....\$122.86

SBC True Roller Race Set .010 undersized.
 For align bored blocks
 COM3100-10.....\$122.86

Chevy V8, 265-400 Adj Timing Set w/Thrust Bearing
 COM3100KT.....\$180.48

Chevy V8, 396-454, '65-96
 COM3110.....\$56.81

BBC True Roller Race Set For align bored blocks
 .005 undersized.....COM3110-5.....\$156.19
 .010 undersized.....COM3110-10.....\$156.19

Chevy V8 396-454 Adj Timing Set w/Thrust Bearing
 COM3110KT.....\$210.57



Reinforced Timing Cover

A replacement for distorted and leaky timing covers. Cover fits SBCs and has a reinforced cam thrust area and gasket flange. Attractive silver iridite finish.
 ALL90010...\$24.99

Timing Cover for SBC w/BBC Seal

Cover fits small block Chevy but has a big block seal. Anodized in black.
 ALL90012...\$99.99

Alum. Timing Covers

Covers will clear most double roller timing chains.

SBC...ALL90008...\$32.99
 BBC...ALL90009...\$48.99

Engine Fastener Kit ARP

Everything you need in one convenient kit. Includes: Intake Manifold bolts, Valve Cover bolts, Thermostat Housing bolts, Alternator Bracket bolts, Oil Pan bolts, Header bolts, Front Cover bolts, Water Pump bolts, and Fuel Pump bolts.



Chrome Moly Black Oxide Hex		12-Point		Stainless 300 Hex		12-Point	
350-400 Chevy	ARP534-9801 \$112.31	ARP534-9701 \$112.31		ARP534-9601 \$143.99	ARP534-9501 \$143.99		
396-454 Chevy	ARP535-9801 \$126.41	ARP535-9701 \$126.41		ARP535-9601 \$166.28	ARP535-9501 \$166.28		
289-302 Ford		ARP554-9701 \$201.72			ARP554-9501 \$258.88		
351W Ford		ARP554-9703 \$100.39			ARP554-9503 \$185.44		

Pro Series LW "I" Beam Connecting Rods

Many other lengths available, call. Forged from 4340 aircraft quality vacuum degassed material. Manufactured in our own CNC machining centers. Fully machined to produce the lightest and strongest rod possible. Shot peened after machining to Mil specs and 100% individually magnafluxed. Cap fasteners are 7/16" MAN230 (230,000 psi) ARP cap screws. Horsepower range for these rods is 750+ hp (small block) and 850+ (big block).

Small Block.....Length.....Journal Size...Center to Center...Gram Weight		
MAN14450-8.....Stock.....Small.....5.700".....597		\$1458.16
MAN14454-8.....300" Longer.....Small.....6.000".....606		\$1458.16
MAN14350-8.....Stock.....Large.....5.700".....599		\$1458.16
MAN14354-8.....300" Longer.....Large.....6.000".....607		\$1458.16

Big Block.....Length.....Center to Center...Gram Weight		
MAN14160-8.....Stock.....6.135".....781		\$1559.90
MAN14162-8.....250" Longer.....6.385".....786		\$1559.90
MAN14166-8.....400" Longer.....6.535".....805		\$1559.90

Thermostat Housing Bolts

These premium grade bolts are engineered to properly engage the manifold threads and resist loosening. They're application specific, and come in your choice of black oxide finished chrome moly or rust-proof stainless steel, with handy 12-point or standard hex heads. Washers included.

Chevy 3 Pcs UHF: 1.00/2.00

Black Oxide Hex.....ARP130-7402.....	\$6.86
Black Oxide 12-Point.....ARP130-7401.....	\$6.86
Stainless 300 Hex.....ARP430-7402.....	\$8.49
Stainless 300 12-Point.....ARP430-7401.....	\$6.63

4340 I-Beam Rods

High Tensile 4340 Chrome Moly. Doweled cap for superior fit. 12 pt ARP 8740 bolts. Sized and balanced. Bushed pin. 2.100 journal. Set of 8.



Add -7/16 at the end of the part # for ARP 8740 7/16" Cap Screw Bolt

SBC, 5.700".....SCA2-ICR5700.....	\$268.33
SBC, 6.000".....SCA2-ICR6000.....	\$268.33
SBC, 6.125".....SCA2-ICR6125-7/16.....	\$326.85
SBC, 6.200".....SCA2-ICR6200-7/16.....	\$326.85

BBC, 6.135".....SCA2-ICR6135.....	\$306.15
BBC, 6.385".....SCA2-ICR6385.....	\$306.15

4340 H-Beam Rods

High Tensile 4340 Chrome Moly. Doweled cap for superior fit. 12 pt ARP 8740 bolts. Sized and balanced. Bushed pin. 2.100 journal. Set of 8.



Add "A" at the end of the part # for ARP 2000 7/16" Cap Screw Bolts

SBC, 5.700", 2.000" PIN.....SCA2-350-5700-2000.....	\$457.10
SBC, 6.000", 2.000" PIN.....SCA2-350-6000-2000.....	\$457.10
SBC, 6.125", 2.000" PIN.....SCA2-350-6125-2000.....	\$457.10
SBC, 6.200", 2.000" PIN.....SCA2-350-6200-2000.....	\$456.74
SBC, 5.700", 2.100" PIN.....SCA2-350-5700-2100.....	\$411.70
SBC, 5.850", 2.100" PIN.....SCA2-350-5850-2100.....	\$442.46
SBC, 6.000", 2.100" PIN.....SCA2-350-6000-2100.....	\$411.70
SBC, 6.125", 2.100" PIN.....SCA2-350-6125-2100.....	\$442.46

BBC, 6.135", 2.200" PIN.....SCA2-454-6135-2200.....	\$442.66
BBC, 6.385", 2.200" PIN.....SCA2-454-6385-2200.....	\$442.66
BBC, 6.535", 2.200" PIN.....SCA2-454-6535-2200.....	\$442.66



Timing Pointers

CNC-machined, black anodized billet aluminum timing pointers are fully adjustable and provide precise timing increments.



SBC 6-1/4" Dia. Fluidampr Bal.....ALL90023.....	\$28.99
SBC 6-3/8" Dia ATI Bal.....ALL90020.....	\$28.99
SBC 7" Dia ATI Bal.....ALL90021.....	\$28.99
SBC 7-1/4" Dia Fluidampr Bal.....ALL90024.....	\$28.99
SBC 8" Dia Fluidampr Bal.....ALL90025.....	\$28.99
BBC 6-1/4" Fluidampr Bal.....ALL90026.....	\$28.99
BBC 7" Dia ATI Bal.....ALL90022.....	\$28.99
BBC 8" Dia Fluidampr Bal.....ALL90027.....	\$28.99
SBF, SVO B, 3/8" Bolt.....ALL90034**.....	\$59.99
SBF, SVO C, 3/8" Bolt.....ALL90035*.....	\$59.99
SBF, SVO B, 5/16" Bolt.....ALL90036**.....	\$59.99
SBF, SVO C, 5/16" Bolt.....ALL90037*.....	\$59.99

* 10 O'Clock Tab Position ** 11 O'Clock Tab Position



Big Block Chevy

Dart Block with Dart Heads, 12pt	Head Stud Kit	ARP235-4317	\$262.28
Dart Block with Dart Heads, hex	Head Stud Kit	ARP235-4117	\$224.42
Cast block w/Brodix SR20 heads	Head Stud Kit	ARP235-4323	\$258.29

Small Block Chevy

LS-RHS Block w/RHS LS7 head	Head Stud Kit	ARP234-4339	\$593.76
Short, 12pt	Water Pump Bolt Kit	ARP134-3203	\$13.75
Short, hex	Water Pump Bolt Kit	ARP134-3204	\$13.31
Short, 12pt	Water Pump Bolt Kit	ARP434-3203	\$21.43
Short, hex	Water Pump Bolt Kit	ARP434-3204	\$20.71
LS Series w/12" clutch	Pressure Plate Bolt Kit	ARP134-2203	\$15.01
Dart SHP	Main Bolt Kit	ARP134-5204	\$58.76
Dart SHP	Main Stud Kit	ARP134-5605	\$93.66
Dart LS Next (15 bolt)	Head Stud Kit	ARP234-4340	\$329.66
Dart LS Next (23 bolt)	Head Stud Kit	ARP234-4341	\$513.03
Dart LS Next	Main Stud Kit	ARP134-5901	\$151.50

Timing Pointer

Adjustable Aluminum Timing Pointer (Use with ALL90030) ALL90031.....

\$35.99

ARP Coil Bracket Bolt Kits

Add a touch of class to your coil bracket installation with an ARP bolt kit. Available in black oxide finished chrome moly or rust-proof stainless steel, as well as with a conventional hex head or compact 12-point (great for use with those coils mounted in tight, hard-to-reach places). Washers included. Coil bracket bolts also included in ARP's popular Engine and Accessory kits.

Chevy Black Oxide Hex ARP130-2302.....	\$3.52
--	---------------



ARP235-4317	\$262.28
ARP235-4117	\$224.42
ARP235-4323	\$258.29

ARP234-4339	\$593.76
ARP134-3203	\$13.75
ARP134-3204	\$13.31
ARP434-3203	\$21.43
ARP434-3204	\$20.71
ARP134-2203	\$15.01
ARP134-5204	\$58.76
ARP134-5605	\$93.66
ARP234-4340	\$329.66
ARP234-4341	\$513.03
ARP134-5901	\$151.50



Manual Piston Ring Filer

To assure proper piston ring end-gap position the piston ring firmly against the dowel pins, crank the handle to turn the abrasive wheel. Using a feeler gauge, file the piston ring to meet the manufacturer's specification.

ROC66785.....**\$58.02**

Replacement 120 Grit Grinding Wheel

ROC66786.....**\$10.63**

JAZ Products Storage Containers

Krank Kase

- Stores crankshaft in a clean safe environment
- Available for Small Block and Big Block Chevy
- Small block fits 350 and 400 style cranks
- Built in recesses allow for multiple stacking
- Keeps harmful dirt and moisture out
- Great for transporting to and from machine shop
- Strong enough to be used as shipping containers
- 360 degree handles make them easy to carry

SBC...JAZ700-300-07...**\$75.98**

BBC...JAZ700-301-11...**\$75.98**

ARP Flexplate Bolt Kits

Chevy 90° V6 & 265-454 V8 with 2 pc. rear seal UHF: 0.680 • Thread Size: 7/16-20

High Performance.....ARP100-2901.....	\$10.86
Pro Series.....ARP200-2902.....	\$15.59

Torque Converter Bolts

You can forget about the problem of shearing a torque converter bolt after you install these super strong 200,000 psi gems. Kits come with hardened parallel-ground washers.

GM Powerglides TH350 & TH400...UHL.....Thread Size

w/ production converter.....750.....3/8-24	ARP230-7301.....	\$17.44
w/ most aftermarket converter.....725.....7/16-20	ARP230-7302.....	\$11.52

w/ race converter 1/2" thick tabs.....1.250.....7/16-20	ARP230-7303.....	\$13.69
---	------------------	----------------

Clutch Cover/Pressure Plate Bolt Kits

Tarp offers High Perf Series bolts that are made from a premium grade chrome moly and hardened to a nominal tensile strength of 180,000 psi. The Pro Series bolts, originally developed for NASCAR Winston Cup competition, are stronger and rated at 200,000 psi. Both models feature a large diameter, low-profile design. Complete with washers.

Thread Size: 3/8-16

Chevy 265-502 V8..High Perf.....ARP130-2201.....	\$13.96
Pontiac 350-455 V8.Pro Series.....ARP290-2201.....	\$28.99

Auto Trans Pan Bolt Kits

Here's another area in which ARP provides a superior strength fastener that will provide better reliability than the OEM hardware. Made of rust-proof stainless steel, they're attractive, too. Includes washers.

GM Turbo 350-400.....ARP430-0401.....**\$21.65**



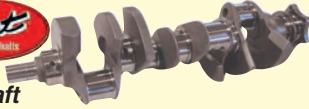

Superlight 4340 Crankshaft

44 lb. overall weight. Micropolished, Nitride hardened and straightened. Airplane wing design counterweights. Lightening holes in rod throws. Large fillet radii on all journals.

Stroke...Weight...Rod.....Small Block

3.480".....43 lbs.....5.700".....SCA4-350-3480-5700-3.....\$1363.87

3.480".....43 lbs.....5.700".....SCA4-350-3480-5700-3-2IN..\$1440.60

Stroke...Weight...Rod.....Big Block

4.000".....59 lbs.....6.385".....SCA4-454-4000-6385-3.....\$1607.11

4.250".....59 lbs.....6.385".....SCA4-454-4250-6385-3.....\$1607.11



Standard Weight 4340 Crankshaft

Micropolished, Nitride hardened & straightened. Heat treated & shot peened. Lightening holes in rod throws. Large radii on all journals.

Stroke.....Weight.....Rod.....Small Block Chevy

3.480".....51 lbs.....5.700".....SCA4-350-3480-5700..\$618.12

3.500".....51 lbs.....5.700".....SCA4-350-3500-5700..\$617.92

3.750".....52 lbs.....5.700".....SCA4-350-3750-5700..\$617.92

3.750".....53 lbs.....6.000".....SCA4-350-3750-6000..\$617.92

Stroke.....Weight.....Rod.....Big Block Chevy

4.000".....68 lbs.....6.135".....SCA4-454-4000-6135..\$727.97

4.000".....71 lbs.....6.385".....SCA4-454-4000-6385..\$727.97

Chevy Forged 4340 Lightweight Pro Comp Crankshafts

Profiled aero-wing counterweights, straight shot and chamfered oil holes, nitride hardened for superior wear resistance, lightening holes in all rods throws, large radius on all journals, CNC machined for absolute tolerances & symmetry for ease of balance.

SBC 350 & 400 Main 2-PC Rear Seal

Stroke.....Rod.....Part

3.480".....5.700".....SCA4-350-3480-5700-2.....\$1125.77

3.500".....5.700".....SCA4-350-3500-5700-2.....\$1125.77

3.750".....5.700".....SCA4-350-3750-5700-2.....\$1125.77

3.750".....6.000".....SCA4-350-3750-6000-2.....\$1125.77

Big Block Chevy 454 Main 2-PC Rear Seal

Stroke.....Rod Length

4.000".....6.135" ext balanced, std rod.....SCA4-454-4000-6135-2

4.000".....6.385" long rod, internal.....SCA4-454-4000-6385-2

4.250".....6.135" 4 lightening holes, standard rod.....SCA4-454-4250-6135-2

4.250".....6.385" .250 long rod.....SCA4-454-4250-6385-2

\$1470.00



Series 9000 Chevy Cast Pro Comp Stroker LW Crankshaft

A perfect way to increase cubic inches on mild to moderate street or race engines. Aero-wing counterweights increase horsepower. Lightening holes in all rod throws (except 3.480 stroke), precision ground and micropolished. Designed after our custom billets and made from Scat's exclusive space age 9000 material.

SBC 350 & 400 Main, 1 piece & 2 piece Rear Seal

Description.....Stroke.....Rod Length.....Rod Pin

350 2-PC Rear Seal.....3.480.....5.700.....2.100

SCA9-350-3480-5700.....\$221.44

350 2-PC Rear Seal.....3.750.....5.700.....2.100

SCA9-350-3750-5700.....\$221.44

350 2-PC Rear Seal.....3.750.....6.000.....2.100

SCA9-350-3750-6000.....\$221.44

Stock Replacement Crankshaft

Precision ground and micropolished, balanced and ready to install out of the box.

350 Chevy - 2 pc rear seal.....SCA9-10442.....\$187.55

350 Chevy - 1 pc rear seal.....SCA9-10526.....\$186.97

454 Chevy - 2 pc rear seal.....SCA9-10454.....\$260.64



Main Studs

SBC Big Journal	2 Bolt Main.....Set
BBC	ARP134-5401.....\$64.36
SBF 289-302	ARP135-5402.....\$85.12
351 Windsor	ARP154-5401.....\$63.66
	ARP154-5403.....\$80.97



4 Bolt Main Set	ARP134-5601.....\$97.47
	ARP135-5601.....\$161.84
	ARP154-5606.....\$145.22

Cam Bolt Kits

ARP quality delivers increased pre-load clamping force and assures positive timing gear register. Increased material strength overcomes valve train harmonics and stress.

Chevy 265-454 cid

Socket Size: 1/2" • Dia/Thread Size: 5/16-18 • UHL .750

High Perf. 180,000 psi.....ARP134-1001.....\$4.54

Pro Series 200,000 psi.....ARP234-1001.....\$5.64

Chevy 265-454 cid with oversize head for use with cam button

Socket Size: 7/16" • Dia/Thread Size: 5/16-18 • UHL .750

Pro Series 200,000 psi.....ARP300-1001.....\$7.10



Flywheel Bolt Kits

High Perf. series is rated at 180,000 psi, and the premium grade Pro Series, originally developed for NASCAR Cup competition, has a 200,000 psi rating. Complete with washers and nuts where applicable.

Application (High Performance is rated 180,000 psi) ...UHF.....Thread Size...Part

Chevy 90° V6 & 265-454 V8 with 2 pc. rear seal.....1.000.....7/16-20.....ARP100-2801 \$10.98

Ford 289-460 V8.....1.000.....7/16-20.....ARP100-2801 \$10.98

Application (Pro Series is rated 200,000 psi).....UHF.....Thread Size...Part

Chevy 90° V6 & 265-454 V8 with 2 pc. rear seal.....1.000.....7/16-20.....ARP200-2802 \$18.54

V8 with Tilton flywheel, uses 1/2" socket.....0.875.....7/16-20.....ARP330-2801 \$36.64

Ford 289-460 V8.....1.000.....7/16-20.....ARP200-2802 \$18.54

Honda 1.6L, 1.7L, 1.8L & 2.0L DOHC, B Series (8 pcs.)...0.990.....M12 x 1.0.....ARP208-2802 \$55.68

Pontiac 350-455 V8 with washers (6 pcs.).....1.000.....1/2-20.....ARP290-2802 \$35.35

Oil Pump Driveshaft Kits for Chevy Drives

Made from premium grade 8740 and heat-treated to 190,000 psi, ARP uses a unique manufacturing process where the alignment sleeve is roll formed onto the shaft (not welded or pinned), enabling the sleeve to float, allowing for slight misalignment.

Small Block Chevy.....ARP134-7901.....\$15.74

Big Block Chevy.....ARP135-7901.....\$16.50

Oil Pump Driveshaft Kits for Ford Drives

Made from ARP2000 and heat-treated to 220,000. These pump drives feature a CNC milled (not broached) hex, and has the retaining washer installed.

Ford 289-302 cid & Boss 302.....ARP154-7904.....\$20.67

Ford 351W.....ARP154-7901.....\$20.67

Oil Pump Bolts and Studs

You've probably heard many a horror story about someone losing an engine when the oil pump fell off into the pan because of a broken bolt. Well, you can put your mind at ease when using ARP's premium grade oil pump bolt and stud kits. You have a choice of black oxide finished 8740 chrome moly steel or low maintenance stainless steel.

SBC, stud kit

Hex Black Oxide.....ARP230-7001.....\$5.82

12-Point Black Oxide.....ARP230-7002.....\$6.86

SBC and BBC, 3.125", high volume, stud kit

Hex Black Oxide.....ARP230-7003.....\$5.82

12-Point Black Oxide.....ARP230-7004.....\$6.86

4.000.....ARP900-0000..\$58.16

4.030.....ARP900-0300..\$58.16

4.040.....ARP900-0400..\$58.16

4.060.....ARP900-0600..\$58.16

4.125.....ARP900-1250..\$58.16

4.135.....ARP900-1350..\$58.16

4.155.....ARP900-1550..\$58.16

4.280.....ARP900-2800..\$61.53

4.310.....ARP900-3100..\$61.53

4.470.....ARP900-4700..\$61.53

4.500.....ARP900-5000..\$61.53

4.560.....ARP900-5600..\$61.53

4.600.....ARP900-6000..\$61.53

4.625.....ARP900-6250..\$61.53

78.00mm.....ARP901-7800..\$61.29

95.00mm.....ARP901-9500..\$61.29

Carrier Fasteners

When assembling a rear end, optimum reliability can be obtained by employing these rugged chrome moly bolts and studs.

Ford 9" Carrier Bearing Stud Kit UHL: 3.250 • Thread: 1/2-13, 1.2-20.....ARP250-3004.....\$29.65

Ford 9" Housing Stud Kit (10 pcs.) UHL: 1.645 • Thread: 3/8-24.....ARP250-3005.....\$32.61





Add "F" to Above Part #'s for smaller 49cc Chamber!

FOR MORE COMPRESSION!

SBC Platinum Series Heads



Features: 10% more air flow. Redesigned combustion chambers. Refined casting techniques. Hardened exhaust seats for better durability with unleaded fuel. Phosphorus exhaust guides. Manganese intake guides. 5 angle competition valve jon on intake, full radius on exhaust valve. Accepts most stock bolt-on components.

Port Cham	Int/Exh	Spring				
Vol	Vol	Valves	Dia	Notes	Part #	Price
200	64	2.02/1.60 VJ	---	Bare	DAR10310010P	\$426.02
200	64	2.02/1.60	1.250S	---	DAR10311111P	\$643.67
200	64	2.02/1.60	1.437D	---	DAR10311112P	\$678.40
200	64	2.02/1.60	1.550D	---	DAR10311113P	\$713.06
215	64	2.05/1.60 VJ	---	Bare	DAR10510020P	\$425.71
215	64	2.05/1.60	1.437D	---	DAR10511122P	\$678.40
215	64	2.05/1.60	1.550D	---	DAR10511123P	\$713.06
230	64	2.08/1.60	1.550D	---	DAR10711143P	\$713.06



High Tech SS Roller Rockers



Using 15-5 PH stainless, a premium alloy, they are the choice of professionals. Tested to 52,000 psi! Extra large trunions and more needle bearings spread out the load.

Desc	Stud	Ratio	
SBC	3/8"	1.6	COM1102-16 \$333.85

Magnum Rocker Arms



Magnums have low friction roller tips to reduce valve stem and guide wear, and keep an engine in race winning condition.

Description	Stud	Ratio	
Chevy V8 265-400	3/8"	1.52	COM1412-16.. \$164.30
Chevy V8 265-400	3/8"	1.6	COM1416-16.. \$167.93
Chevy V8 396-454	7/16"	1.72	COM1411-16.. \$167.93
Chevy V8 265-400	3/8"	1.52	COM1417-16.. \$189.91
Chevy V8 265-400	3/8"	1.6	COM1418-16.. \$189.91

Ultra-Gold Aluminum Rocker Arms



Best of all, they are built to withstand extremely aggressive spring pressures and valve springs with as much as a 1.650-inch O.D., a feature not possible with any other rocker arm.

SBC V8 265-400, V6 200-262			
3/8"	1.5	COM19001-16	\$334.66
3/8"	1.6	COM19002-16	\$334.66
7/16"	1.5	COM19004-16	\$334.66
7/16"	1.6	COM19005-16	\$334.66
BBC V8 396-454			
7/16"	1.7	COM19021-16	\$373.97
SBF V8 289-302, 351W			
3/8"	1.6	COM19043-16	\$338.69
7/16"	1.6	COM19044-16	\$338.69

Cylinder Head Bolts

170,000 psi bolts are 15% stronger than grade 8 bolts. Available in hex or 12-point head, and include hardened parallel-ground washers.

	Hex Head Set	12-Point Head Set
Buick V6, Duttwieler & M&A alum. heads	ARP123-3602	\$81.49

Small Block Chevy

Dart II heads	ARP134-3602	\$98.48	ARP134-3702	\$98.48
Cast iron OEM, LT-AFR, Brodix -8, -10, -11, -11xb	ARP134-3601	\$88.12	ARP134-3701	\$92.57

Big Block Chevy

Cast Iron OEM	ARP135-3601	\$88.12	ARP135-3701	\$92.57
Late Bowtie Alum., World Prod Merlin, Iron Dart	ARP135-3603	\$122.33	ARP135-3703	\$128.44
Mk V Block w/World Merlin, Late Bowtie, and Dart Alum.	ARP135-3607	\$117.05	ARP135-3707	\$122.20
Mk V or Mk IV w/ Brodix alum.	ARP135-3609	\$129.97	ARP135-3709	\$117.58

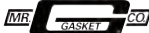

BBC Manifold Bolt Kit

These Grade 5 hex head bolts are brite zinc plated for protection and appearance. Hardened flat washers provide uniform torque & prevent galling on aluminum manifolds. MRG954G \$12.17



Intake Manifold Bolt Kit

3/8-16 x 1" - 12 pieces w/ Washers Fits SBC V8 1955-1995 265-400 Fits SB Chrysler V8 1964-1986 273-360 Fits BB Chrysler V8 1959-1980 361-440 (does not fit 426 Hemi) Fits AMC V8 290-401. Zinc Plated. Grade 5 Quality Steel. Washers Included. MRG955G \$9.93

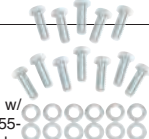

Chevy Intake Manifold Bolt Kit Socket Head

3/8-16 x 1". These Grade 5 hex head bolts are black coated plated for protection and appearance. Hardened flat washers provide uniform torque & prevent galling on aluminum manifolds. Internal Allen Head MRG956G \$12.17 Hex Head MRG957G \$13.27



Intake Manifold Bolt

Small Block Chevy 3/8"-16 x 1.00" 12-Pt Head w/ Washers
Fits: SBC V8 & 90° V6, Chrysler 273-360 V8 1964-'91, Chrysler 361-440 V8 1959-'79 (all except 426 Hemi), American Motors 290-401 V8. MRG6091 \$22.13

Big Block Chevy 12-Point Head w/ Washers

These Grade 8 bolts have a 12 pt smaller-than-standard head & flange, ideal where space is tight. Extra thick washers supply optimum clamping. Bright zinc plated. MRG6093MRG \$34.33

Head Bolt Washer Kit

7/16 Head Bolt Washer Kits are manufactured from high-grade steel and come in a corrosion-resistant zinc finish. .120-inch thick, consistent clamp load and optimum gasket seal every time, and come in sets of 34. MRG87 \$14.38

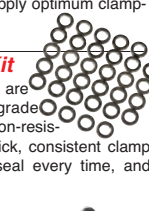

Sportsman Series Shaft Rockers

Affordable upgrade from stud rockers eliminates the need for studs, guide plates, polylocks & stud girdles. Fits SBC with standard valve spacing.
1.5 in./1.5 ex. JES-KSS-335050 \$1225.00
1.6 in./1.5 ex. JES-KSS-336050 \$1225.00
1.6 in./1.6 ex. JES-KSS-336060 \$1225.00



Pro Series Rocker Arm System & Competition Series Rocker Arm Systems. Call for Application!



Small Block Chrysler

	Hex Head Set
"A" block w/W2	ARP144-3601 \$79.57
"A" block 273-360	ARP144-3602 \$87.96

Big Block Chrysler

B & RB Wedge 383-440 7/16"	ARP145-3606 \$101.90
----------------------------	----------------------

Small Block Ford

289-302 std.	ARP154-3601 \$53.16
351 Windsor	ARP154-3603 \$89.08
Fontana SVO,	
Yates Head	89.08 \$89.08

Big Block Ford

390-428 FE, 460	ARP155-3601 \$91.22
-----------------	---------------------

Stud Girdles



The valves not opening if the stud is flexing. These stud girdles keep it all where it's supposed to be. In your choice of spring loaded (2 piece design) or solid bar (1 piece design).



Desc. Stud Design

SBC .3/8".....solid bar.....	COM4007	\$221.24
SBC .7/16".....solid bar.....	COM4009	\$221.24
SBC .3/8".....spring loaded.....	COM4001	\$243.84
SBC .7/16".....spring loaded.....	COM4004	\$243.84
BBC .7/16".....solid bar.....	COM4021	\$321.33



Rocker Arm Stud Kits

	High Perf.....Set	Pro Series.....Set
Small Block Chevy		
3/8"	ARP134-7101 \$51.15	ARP234-7201 \$91.39
7/16" 1.770" OAL	ARP134-7103 \$51.15	ARP234-7202 \$91.39
7/16" roller rocker	ARP100-7101 \$45.79	

Big Block Chevy

OEM	ARP135-7101 \$51.17	ARP235-7201 \$91.39
Alum. head exh. only		ARP235-7203 \$67.93
Alum. head int. only		ARP235-7204 \$67.93

MANLEY Stainless Steel Valves

Severe Duty Valves made from XH-428 (exh.) and NK-844 (int.). Chrome stems and hard tips. Swirl polished and fully machined. Stem Diam. 3415.

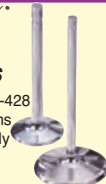

Small Block Chevy - set of 8

Type	Head Dia	Installed Height	
Intake	2.02	stock	MAN11596-8 \$223.84
Intake	2.02	100 longer	MAN11826-8 \$223.84
Intake	2.05	stock	MAN11598-8 \$223.75
Intake	2.05	100 longer	MAN11846-8 \$231.84
Exhaust	1.60	stock	MAN11595-8 \$223.84
Exhaust	1.60	100 longer	MAN11539-8 \$223.84

Big Block Chevy - set of 8

Type	Head Dia	Installed Height	
Intake	2.19	stock	MAN11800-8 \$223.84
Intake	2.19	100 longer	MAN11822-8 \$231.75
Exhaust	1.88	stock	MAN11843-8 \$223.84
Exhaust	1.88	100 longer	MAN11815-8 \$223.84
Exhaust	1.90	stock	MAN11817-8 \$223.84
Exhaust	1.90	100 longer	MAN11811-8 \$223.84

Superior Head Bolts

SBC V-8.....	MAN42171.....	\$27.91
SBC Brodix -12 & Pontiac 10093328	MAN42312.....	\$27.91
SBC Brodix Alum & pontiac 10033867		
	MAN42313.....	\$27.91
BBC	MAN42170.....	\$27.91
BBC with Brodix Heads	MAN42192.....	\$27.91
BBC w/Bow Tie, Dart alum or Merlin heads	MAN42322.....	\$27.91

7/16" Head Stud Kits

SBC w/flat heads flat milled	MAN42190	\$256.88
BBC w/Dart & bow Tie heads flat milled	MAN42283	\$266.76
BBC w/non-Bow Tie heads flat milled	MAN42191	\$271.70



Motor Mount Bolts

Secure any engine with complete confidence with ARP's rugged motor mount bolts. You can choose between black oxide finished 8740 chrome moly or corrosion-resistant stainless steel; choice of hex or 12-point head. Kits come complete with flat washers.

Chevy All V6 and V8	
Black Oxide Hex..	ARP130-3102.....\$10.85

Perma-Loc

The ultimate valve adjusting lock. Made of premium 8740 chrome moly, heat treated and flush ground to apply even pressure to rocker.



Stamped Steel Rocker

3/8-24	ARP300-8241	\$79.75 set
7/16-20	ARP300-8245	\$79.75 set

Aluminum Rocker

3/8-24	ARP300-8243	\$79.75 set
7/16-20	ARP300-8245	\$79.75 set
w/Stud Girdle		
7/16-20	ARP300-8247	\$220.94 set



Racing Cams

Most of the cams listed here are from Comp's "Magnum" series. These are the more popular part #s, but we stock others. Please call for your application.

Application	Lifters	RPM Range	In. Dur.	Ex. Dur.	In. Lift.	Ex. Lift.	Lobe Sep.	Part #
SBC, pro street/bracket, limited street, intake, gears, 3500 stall, 10.5:1, racy idle	Hyd	3000 to 7000	305	305	525	525	110°	COM12-214-4 \$145.63
SBC, street/strip, 3500+ stall, low gears, intake, headers, 10.5:1, racy idle	Solid	3000 to 7000	306	306	555	555	110°	COM12-225-4 \$145.63
SBC, oval, 1/4 - 3/8 mile, broad torque range	Hyd	3500 to 6300	286	292	490	485	108°	COM12-330-4 \$145.63
SBC, oval, short tracks, small engines in heavy car, very good torque	Solid	2800 to 6200	280	285	507	532	106°	COM12-608-5 \$193.32
SBC, oval, 1/4 - 3/8 with fast corners	Solid	3700 to 7000	290	304	540	534	106°	COM12-611-5 \$193.32
SBC, tight lash, 327-350 on short track, 2 bbl. and cast manifold	Solid	2800 to 6300	276	280	520	530	106°	COM12-500-5 \$193.32
SBC, tight lash, 350-400 on big 3/8 to 1/2 mile, sustained high rpm. Big carb and good intake	Solid	3000 to 6700	280	288	530	550	106°	COM12-512-5 \$193.32
SBC, good winged sprint, aggressive intake, more torque	mech. roller	3800-to 7000	288	300	660	630	106°	COM12-910-9 \$360.55
SBC, 355 Late Model on 1/4 - 3/8, good heads and intake	mech. roller	3000 to 7000	290	300	645	630	106°	COM12-940-9 \$360.55
SBC, drag, 3000+ stall in heavy car, 10:1	Hyd	2500 to 6500	292	292	501	501	110°	COM12-213-3 \$135.55
SBC, drag, 3500-4000 stall or 4 spd, 11:1	Hyd	3500 to 7000	305	305	525	525	110°	COM12-214-4 \$145.63
SBC, drag, 4000 stall, 12:1	Solid	3500 to 6500	280	288	530	550	106°	COM12-512-5 \$193.32
SBC, drag, 4000 stall, 10.5:1 and up	Solid	4000 to 7000	290	304	540	534	106°	COM12-611-5 \$193.32

Mechanical Roller Available



Hi-Tech Endurance Valve Springs

Part #	Price	I.D.	Seat Load	Open Load	Coil Bind Rate (Lbs./In.)	Description
COM26089-16	\$406.02	.812	230 @ 2.000	580 @ 1.300	1.230	500 1.550 2 Spring Assembly Pacaloy material
COM26094-16	\$301.59	.752	174 @ 1.900	441 @ 1.300	1.200	445 1.550 2 Spring Assembly Chrome Silicone material
COM925-16	\$121.56	.697	122 @ 1.900	340 @ 1.350	1.100	395 1.510 2 Spring Assembly w/Damper (920/975)
COM951-16	\$351.79	.846	230 @ 1.950	710 @ 1.200	1.100	640 1.620 Inter-Fit Pacaloy



Lifters



Description (Fit SBC or BBC)	Part #	Price
High Energy Hyd.	COM812-16	\$81.85
(RV or OEM replacement)		
Pro Magnum Hyd. (high rpm)	COM858-16	\$99.59
Solid (SBC or BBC)	COM813-16	\$110.26
Solid	COM833-16	\$98.38
(Ford or Chevy w/.875" lifter bore)		

High Tech Roller Lifter

Hi-Tech Roller Lifters (SBC)	COM818-16	\$430.42
Hi-Tech Roller Lifters (BBC)	COM819-16	\$430.42



Pushrods

The thick-walled, Hi-Tech Racing Push Rods are powered forged of 4130 chrome moly and heat treated for more strength. One-piece design, with an .080" wall thickness, pushrods are black oxide finished w/ a minimum hardness of 60 on the Rockwell "C" scale.

Part #	Diameter/Wall	Description	Length	set of 16
COM7972-16	5/16"/.080"	stock SBC	7.800"	\$147.17
COM7974-16	5/16"/.080"	+ .050" Long	7.850"	\$147.17
COM7993-16	5/16"/.080"	+ .100" Long	7.900"	\$147.17
COM7994-16	5/16"/.080"	+ .150" Long	7.950"	\$147.17
COM7995-16	5/16"/.080"	+ .200" Long	8.000"	\$147.17
COM7996-16	5/16"/.080"	+ .250" Long	8.050"	\$147.17
COM7997-16	5/16"/.080"	+ .300" Long	8.100"	\$147.17

Fuel Pump Pushrods

When a high press fuel pump is run w/a steel roller cam core, the stock one isn't compatible w/the steel core. You can damage an expensive roller cam as a result of wear at the fuel pump lobe.

LW Tubing w/Bronze Tip for Steel Cam	COM4607	\$14.95
Olds Rocket Block w/Bronze Tip for Steel Cam	COM4620	\$18.27
Steel Rod w/Roller Tip (Not for BBC)	COM4609	\$123.37
LW Tubing w/Steel Tip for Cast Iron Cam	COM4616	\$18.68
Chrysler 383-440, Hemi w/Steel Tip	COM4626*	\$22.65
Chrysler 383-440, Hemi w/Bronze Tip	COM4646*	\$22.15

* For use with cast flat tappet cams only, 3.220" in length.



Pushrod Length Checker

Determine correct pushrod length quickly and easily when building race engines. Made from a thin wall 5/16" pushrod that is cut and threaded with over 1" of travel. Checker has 5/16" ball on each end and extends from 7.5" to 8.7".....COM7901-1.....\$15.06

Fuel Pump Pushrod Kit ARP

They're made from premium grade aerospace chrome moly and centerless ground to precise diameter. A hollow core serves to reduce the reciprocating mass, which requires less energy to operate. Diameter: 1/2" OAL: 5.750

Lightweight HD Fuel Pump Pushrods

SBC Bronze Tip .498" Diameter x 5.750" Long	CV4000-8	\$20.95
SBC Heavy Duty Bronze Tip (Same size as above)...	CV4000-8SD...	\$28.95

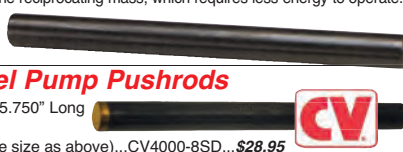

5/16" Pushrods MANLEY

4130 Chrome Moly 5/16" Swaged End Pushrods .080" Wall
Features: Meticulously formed ends with exact radii. Excellent concentricity, closely controlled length. Heat treated and black oxide finished.

Small Block Chevy

Part #	Length	Dimensions	Price
MAN25709-16	265-350 Stock	7.800"	\$121.74
MAN25711-16	.050" Longer	7.850"	\$121.74
MAN25712-16	.100" Longer	7.900"	\$121.74
MAN25733-16	Late Model 350	7.200"	\$121.74
MAN25735-16	LS-1 Stock	7.400"	\$121.74

Small Block Ford

Part #	Length	Dimensions	Price
MAN25627-16	Stock 5.0 L	6.272"	\$121.74
MAN25744-16	Stock 351 W	8.150"	\$121.74
MAN25706-16	Stock 351 C	8.400"	\$121.74
MAN25710-16	Yates +.150"	8.550"	\$121.74

3/8" Pushrods

4130 Chrome Moly 3/8" Swaged End Pushrods .080" Wall
Features: Meticulously formed ends with exact radii. Excellent concentricity, closely controlled length. Heat treated and black oxide finished

Part #	Description	Length	Price
MAN25795-8	BBC - Stock Intake	8.280"	\$70.20
MAN25796-8	BBC - Stock Exhaust	9.250"	\$70.20
MAN25797-8	BBC - 400" Longer Int.	8.680"	\$70.20
MAN25798-8	BBC - 400" Longer Exh.	9.650"	\$70.20

LW Fuel Pump Push Rods MOROSO

LW design with hardened ends reduces reciprocating mass to prevent pump arm float & subsequent fuel starvation.

LW Fuel Pump Push Rod. SBC and BBC	MOR65750	\$22.34
LW Fuel Pump Push Rod. 0.200" longer to fit World Products Merlin and Oldsmobile Rocket Block	MOR65752	\$25.44

SBC Raised Steel Guide Plates MANLEY

Part #	Qty	Pushrods	Slots	Price
MAN42151-8	8	5/16"	On-Center	\$22.53
MAN42150-8	8	3/8"	On-Center	\$29.24

SBC Flat Steel Guide Plates

Part #	Qty	Pushrods	Slots	Price
MAN42355-8	8	5/16"	On-Center	\$18.57
MAN42356-8	8	3/8"	On-Center	\$29.24

BBC Steel Guide Plates

Part #	Qty	Pushrods	Price
MAN42164-8	8	3/8"	\$41.89
MAN42149-8	8	7/16"	\$41.89

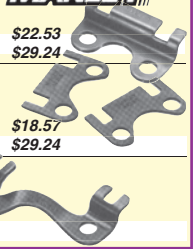

Air Filter Gaskets

Holley, Carter, Q-Jet.....	FEL2104.....	\$8.68
Dominator 4500	FEL2105.....	\$9.83

Carburetor Base Gaskets (Holley)

4150/4777 Open Plenum ..	FEL1900.....	\$5.23
4150/4777 4-Hole 1 3/4".....	FEL1901.....	\$5.31
4500 Dominator Open	FEL1903.....	\$5.32
4412 2-Bbl 1 3/4".....	FEL1904.....	\$4.69

Intake Gaskets 2 per set

SBC, 1.23x1.99 blocked crossover .060.....	FEL1204.....	\$16.04
SBC, 1.23x1.99 open crossover .060.....	FEL1256.....	\$19.06
SBC, 1.08x2.11 Vortec .120 thick.....	FEL1255.....	\$22.28
SBC, 1.25x2.04 LT1 .060 thick.....	FEL1284.....	\$23.11
SBC, 1.28x2.09 rect. .060 thick.....	FEL1205.....	\$16.29
SBC, 1.31x2.02 raised runner .060.....	FEL1263.....	\$20.64
SBC, 1.31x2.21 rect. .060 thick.....	FEL1206.....	\$18.16
SBC, 1.31x2.21 rect. .120 thick.....	FEL1266.....	\$23.27
SBC, 1.38x2.28 rect. .060 thick.....	FEL1207.....	\$18.09
SBC, 1.38x2.28 rect. .120 thick.....	FEL1267.....	\$24.18
SBC, 1.38x2.38 rect. .060 thick.....	FEL1209.....	\$19.73

BBC, 1.82x2.05 stk.oval .060 thick.....	FEL1210.....	\$24.76
BBC, 1.82x2.54 rect. .060 thick.....	FEL1211.....	\$19.45
BBC, 1.90x2.70 spread .060 thick.....	FEL1249.....	\$18.98
BBC, 1.25x2.36 trim to fit .060.....	FEL1251.....	\$19.80
BBC, 1.82x2.54 rect. .060 thick.....	FEL1275.....	\$18.26

SBF, 1.20x2.00 stock .060 thick.....	FEL1250.....	\$25.55
SBF, 1.28x2.10 TFS, GT-40 .060 thick.....	FEL1262.....	\$22.61

Perma Torque MLS Perf Head Gaskets

Fel-Pro perf head gaskets feature a PermaTorque/blue gasket body with a solid-steel core to minimize torque loss and gasket blowout. Fel-Pro performance head gaskets also have a wire-ring combustion seat with stainless steel "armor" for extra sealing force around combustion chambers. Made with a pre-flattened steel-wire ring, Fel-Pro perf head gaskets have the strength of steel-wire sealing and the minimum brinelling of alum heads.

Part #.....Application Notes.....Gasket Bore.....Thickness ..Vol

SBC V8 Gen III - LS-1 and LS-6

FEL1160L.....All, L.H.....	3.945.....	.053.....	10.6.....	\$87.59
FEL1160R.....All, R.H.....	3.945.....	.053.....	10.6.....	\$87.59
FEL1161L.....All, L.H.....	4.100.....	.053.....	11.5.....	\$87.59
FEL1161R.....All, R.H.....	4.100.....	.053.....	11.5.....	\$87.59
FEL1162L.....All, L.H.....	4.175.....	.053.....	11.9.....	\$87.59
FEL1162R.....All, R.H.....	4.175.....	.053.....	11.9.....	\$87.59

SBC V8 - 302, 327, 350, 400 Engines & Specialized Race Engines

FEL1142.....Cast iron or aluminum heads.....	4.100.....	.041.....	9.0.....	\$78.56
FEL1143.....Cast iron or aluminum heads.....	4.165.....	.041.....	9.2.....	\$74.17
FEL1144.....Cast iron or aluminum heads.....	4.200.....	.041.....	9.3.....	\$79.51
FEL1144-1.....SB2 w/outboard cooling.....	4.200.....	.041.....	9.3.....	\$75.73
FEL1144-2.....SB2 w/symmetrical cooling.....	4.200.....	.041.....	9.3.....	\$79.22

BBC V8 - 396, 402, 427, 454 Engines and Specialized Race Engines

FEL1071.....Gen IV, Gen V, Gen VI Engines.....	4.380.....	.041.....	10.6.....	\$83.09
FEL1071-1.....Gen IV, Gen V, Gen VI Engines.....	4.380.....	.053.....	13.7.....	\$102.75
FEL1075.....Gen IV, Gen V, Gen VI Engines.....	4.580.....	.041.....	11.2.....	\$85.28
FEL1075-1.....Gen IV, Gen V, Gen VI Engines.....	4.580.....	.053.....	14.5.....	\$105.24
FEL1077.....Gen IV, Gen V, Gen VI Engines.....	4.640.....	.041.....	11.4.....	\$84.35
FEL1077-1.....Gen IV, Gen V, Gen VI Engines.....	4.640.....	.053.....	14.8.....	\$105.24

Race Set

This sets allow you to purchase the correct specialized gaskets for your particular application separately, while still getting all the commonly used gaskets to complete your rebuild. These sets typically include gaskets and seals for the water pump, timing cover, fuel pump, thermostat housing, oil pump, and a rear main seal.

Small Block	FEL2702.....	\$20.28
Big Block	FEL2703.....	\$29.68

Rigid-Core Molded-Rubber Valve Cover Gaskets

Silicone Molded Rubber with Steel Core, Steel Compression Limiters. 2 per pack.

SBC V8 - 283, 302, 305, 327, 350, 400 Engines	
250 Thickness (Most Cylinder Heads)	
FEL1628.....	\$53.95

BBC V8 - 396, 402, 427, 454 Engines	
.137 Thick (3 Up Bolt Holes & 4 Low Bolt Holes)	
FEL1635.....	\$42.93

Valve Cover Gaskets

Cork gaskets with steel core, 2 per pack.		
SBC, 5/16".....	FEL1604.....	\$34.88
SBC, 1/4" 18" & Brodix ..	FEL1644.....	\$43.72
BBC, 5/16".....	FEL1630.....	\$39.08
SBF, 3/16".....	FEL1613.....	\$15.97
SBF, 5/16".....	FEL1645.....	\$37.05

Full Gasket Sets

Kit: head gaskets, intake manifold gaskets & end seals, exhaust header gaskets, valve stem seals, timing cover gaskets & seal, water pump gaskets, water outlet, oil pan gaskets & seals, rear main, dist mounting seal, oil drain plug seal and valve cover gaskets.

SBC, small intake & exhaust ports, open heat crossover	FEL2802.....	\$125.40
BBC, oval intake, square exhaust ports, open crossover.....	FEL2805.....	\$151.62

Header Gaskets

Perforated Steel Core w/anti-stick coating.		
SBC, 1.38x1.38 stk. square.....	FEL1444.....	\$18.39
SBC, 1.5x1.5 stk. square.....	FEL1404.....	\$16.38
SBC, 1.55x1.55 square.....	FEL1405.....	\$22.59
SBC, 1.53x1.63 D-shaped.....	FEL1406.....	\$20.69
SBC, 1.74x1.60 18" head.....	FEL1482.....	\$28.80
SBC, 1.81 round Hooker/Stahl.....	FEL1407.....	\$22.24
SBC, 2.19 round Hooker.....	FEL1408.....	\$23.18
SBC, 1.81 Brodix spread port.....	FEL1409.....	\$21.81
BBC, 1.94 small race round.....	FEL1411.....	\$22.94
BBC, 2.13 large race round.....	FEL1412.....	\$21.65
SBF, 1.25x1.48 rect.....	FEL1415.....	\$21.92
SBF, 1.40x1.40 J302 & K302.....	FEL1486.....	\$25.14
SBF, 1.42x1.62 Dart & TFS, E351.....	FEL1487.....	\$24.42

Thermostat / Water Outlet Gaskets

3/32" with steel core.....	FEL2201.....	\$8.96
1/8" plastic.molded rubber o-ring.....	FEL2202.....	\$18.60

Rear Main Seals

SBC, 59-85, 2 pc silicone.....	FEL2900.....	\$11.66
SBC, 59-85, 2 pc prem/hi-vac.....	FEL2912.....	\$27.26
SBC, large OD for align bored 400 also tall deck DART/Rocket blocks.....	FEL2909.....	\$23.87
SBC, 86-92, full circle.....	FEL2919.....	\$22.21
BBC, 65-79, silicone 2 pc.....	FEL2904.....	\$13.78
BBC, 91-92 1 pc.....	FEL2920.....	\$22.48
BBC, 65-79 hi vacuum.....	FEL2918.....	\$28.40
SBF, 62-82, 302, 2 pc premium.....	FEL2901.....	\$22.49
SBF, 83-93, 302 351W, 1 pc. prem ..	FEL2921.....	\$24.18
SBF, 82-83, 302 SVO, 1 pc prem.....	FEL2922RS.....	\$15.36

One Piece Oil Pan Gasket

SBC V8 1975-79 thick front seal. Side rails trimmed for strokers.

Left Hand Dipstick.....	FEL1880.....	\$37.42
Right Hand Dipstick	FEL1881.....	\$38.81
Straight Rail	FEL1882.....	\$37.42

BBC V8 Thickness 3/32" Molded rubber, One piece with rigid carrier.....	FEL1884R.....	\$35.43
---	---------------	---------

Oil Pan Gaskets

These gaskets feature a fiber sheet core covered in latex rubber. The core resists crushing and splitting while giving a distinct feel when torqued. The latex offers the ultimate leak protection.

SBC, 57-74, thin front seal, LH dip.....	FEL1802.....	\$12.79
SBC, 75-79, thick front seal, LH dip ..	FEL1803.....	\$14.06
SBC, 80-85, thick seal, RH dip.....	FEL1818.....	\$15.97
SBC, trimmed for strokers,		
thick or thin, L or R dip.....	FEL1821.....	\$27.01
SBC, DART Iron Eagle,		
Olds Rocket, steel core.....	FEL1839.....	\$28.89

BBC, 65-90.....	FEL1804.....	\$15.81
BBC, trimmed for rod clearance,		
steel core.....	FEL1893.....	\$26.41

SBF, 62-92 except 351W.....	FEL1809.....	\$15.12
SBF, 351W.....	FEL1810.....	\$15.35

SBC Head Gaskets

Fel-Pro performance head gaskets have a wire-ring combustion seat w/stainless steel "armor" for extra sealing force around combustion chambers. Made w/a pre-flattened steel-wire ring.

application / bore, volume, thickness		
Iron or alum. 4.166 bore, 9.1cc, .041.....	FEL1003.....	\$38.85
Alum. only 4.166 bore, 8.9cc, .039.....	FEL1010.....	\$48.35
Iron or alum. 400 block 4.200 bore, 9.3cc, .041.....	FEL1034.....	\$45.06
Sm. chamber, not OEM heads, 4.08 bore, 8.2cc, .039.....	FEL1043.....	\$48.17
Iron or alum. must o-ring head 4.166 bore, 9.1cc, .041.....	FEL1045.....	\$70.84
LT-1 & LT-4 only, 4.125 bore, 8.7cc, .039.....	FEL1074.....	\$42.96
Iron or alum. flat top piston 4.100 bore, 3.2cc, .015.....	FEL1094.....	\$23.06

BBC Head Gaskets

Iron or alum. 4.540 bore, 10.9cc, .041.....	FEL1017-1.....	\$46.65
Alum. only, 4.370 bore, 9.7cc, .039.....	FEL1027.....	\$54.58
Iron or alum. 4.370 bore, 9.7cc, .039.....	FEL1037.....	\$48.73
Iron or alum. 4.540 bore, 10.5cc, .039.....	FEL1047.....	\$51.93
Iron or alum. 4.630 bore, 11.3cc, .039.....	FEL1057.....	\$51.12
Iron or alum. Pro-Stock, 4.620 bore, 13.9cc, .051.....	FEL1093.....	\$101.83

SBF Head Gaskets

Must o-ring head, 4.145 bore, 8.7cc, .039.....	FEL1006.....	\$75.23
1962-82, 4.100 bore, 9.0cc, .041.....	FEL1011-1.....	\$37.26
1983-93, 4.100 bore, 8.5cc, .039.....	FEL1011-2.....	\$37.65
302 SVO, 351 SVO, 4.100 bore, 9.2cc, .041.....	FEL1021.....	\$43.77

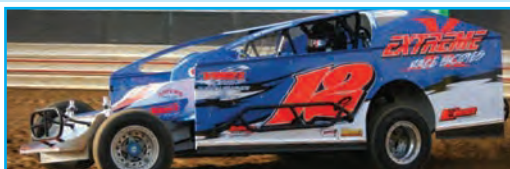

BULK GASKETS

Exhaust Header Gasket

SBC, 1.5 x 1.5 stock, square
FELP1404.....\$8.12



Exhaust Header Gasket

SBC, 1.81 Brodix spread port
FELP1409.....\$9.62



Exhaust Header Gasket

BBC, 1.880, square port
FELP1410.....\$9.11



Exhaust Header Gasket

BBC, 2.13 large race round
FELP1412.....\$9.68



SBC Valve Cover, 5/16"

FELP1604.....\$13.69



BBC Valve Cover, 5/16"

FELP1630.....\$17.56

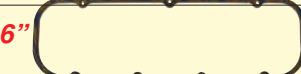

Oil Pan Gasket

Rubber/Steel Core, Chrysler, Dodge,
Plymouth, Big Block, Each
FELP1834.....\$24.57



Head Gasket

Composition Type, 4.410 in. Bore
.039 in. Compressed Thickness,
Chrysler, Big Block, Each Gasket
FELP1009.....\$46.47

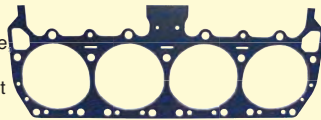

BBC Timing Cover Gasket

FELP45060.....\$0.73

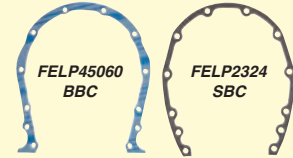

SBC Timing Cover Gasket

FELP2324.....\$1.68

BBC Timing Cover Balancer Seals

FELP16020.....\$3.11



SBC Timing Cover Balancer Seals

FELP14842.....\$1.68



Carb Base Gasket

4-Barrel Sq Flange - 4-Hole - Bulk Packaged

Fits Holley, Carter AFB and AVS, Demon Race, Speed, and Road, and Edelbrock Performer Sq Flange 4 Barrel Carbs. Made from durable 1/16 in thick cellulose/nitrile composite gasket material. Precision die cut for excellent seal and fit. High-Temp Composite Gasket Material.
MRG55.....\$6.62



Carb Gasket Rochester 2bbl LG

It is made from a durable heat-resistant nitrile rubber compound material and precision die cut for an excellent fit. Rochester Carb: 2 bbl - 2 Hole, large base 2" x 3 11/16". (Bulk Packaged, 1/16" Thick).
MRG52.....\$6.62



Carb Base Gasket

4-bbl - Sq Flange - Open Center - Bulk Packaged

Fits Holley, Carter AFB and AVS, Demon Race, Speed, and Road, and Edelbrock Performer Square Flange 4 Barrel Carbs. Made from durable 1/16 in thick cellulose/nitrile composite gasket material. Precision die cut for excellent seal and fit. Can be trimmed if necessary. High-Temp Composite Gasket Material.
MRG54.....\$6.62

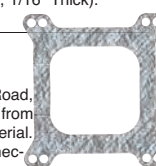

Collector Gasket - Performance - 3"

Collector Gasket, square shape with 3" Dia hole. 4 1/16" bolt circle. Made from Mr.Gaskets Performance Exhaust material.
MRG1205.....\$6.62

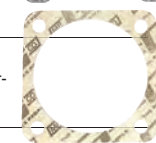

Valve Cover Gasket

262-400 SBC GEN I 1955-86

Cork/Rubber, SBC, Pair. Extra Thick 5/16"
MRG179.....\$26.57



Intake Manifold Gasket Set

262-400 SBC Gen I 1955-91

Fits 1955-'91 SBC w/ Medium size ports.
MRG106.....\$23.23

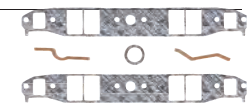

BBC Water Pump Gasket

FELP30060.....\$0.77



SBC & BBC Outlet Water Pump

FELP2200.....\$0.86

SBC Water Pump Gasket

FELP93164.....\$0.45

SBC Water Pump Gasket

FELP5152.....\$0.42

Water Pump Covers

SBC...FEL13032B ..\$0.95
BBC...FEL11725B ..\$0.40

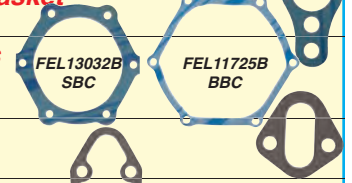

Fuel Pump Gasket

FELP70573.....\$0.39

Fuel Pump Plate Gasket

FELP70576.....\$0.53

SBC Rear Main Seal

FELP2900.....\$10.82

BBC Hi Vacuum Rear Main Seal

FELP29182.....\$19.48

Air Cleaner Housing Seal

FELP2104.....\$10.76

Distributor Gasket

FELP70165.....\$0.34

Exhaust Header Gaskets

They offer exhaust header gaskets made with steel and SS core laminate to provide stability, max torque retention, and excellent heat resistance.



Steel Core Laminate, Brodix Spread Port, Chevy, Small Block, Each

Port Height (in):1.715 in.
Port Width (in):1.665 in.
Thickness (in):0.062 in.
SCH01533.....\$9.50

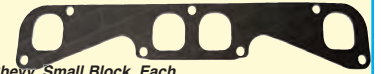

Steel Core Laminate, D Port, Chevy, Small Block, Each

Port Height (in):1.520 in.
Port Width (in):1.480 in.
Thickness (in):0.062 in.
SCH01560.....\$8.00



Exhaust Header Gaskets

1.625 in 1.875 in Round Port, GM LS-Series, Each
SCH01780.....\$10.50



Header Gaskets

396-454 BBC MARK IV 1965-90

Ultra-Seal Material, Round Ports, 1.92"
MRG5911.....\$24.35



396-454 BBC Mark IV 1965-90

Ultra-Seal Material, Round Ports, 2.15"
MRG5912.....\$25.45



302 Boss, 351C Ford Boss 1964-95 - 4 bbl

Ultra-Seal Material, Rectangular Ports, 1.90" x 2.20"
MRG5932.....\$24.35



351C, 351M, 400 Ford Cleveland/Modified 1970-74 - 2 bbl

Ultra-Seal Material, Rectangular Ports, 1.58" x 1.96"
MRG5951.....\$32.51



262-400 SBC GEN I 1955-91

Ultra-Seal Material, Square Port, 1.45" x 1.55"
MRG5901.....\$22.13





Exhaust Header Gaskets

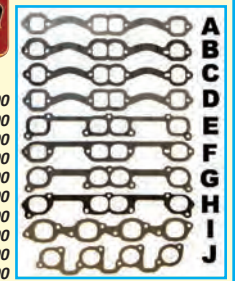

- A.) Small PortBEYHG23SP...\$16.00
- B.) Fast Burn 604BEYHG604\$20.00
- C.) SBC 23"BEYHG23\$20.00
- D.) SBC 23" Dart PlatinumBEYHG23DP\$22.00
- E.) 11x Spreadport 18 Brodix .BEYHG18B\$22.00
- F.) 18" ChevyBEYHG18C\$22.00
- G.) 13" All ProBEYHG13AP\$22.00
- H.) Gasket.....BEYHG913\$22.00
- I.) Big BlockBEYHGBBC\$20.00
- J.) Ford Yates D3/SC1.....BEYHGF3\$26.00



Carbon Steel Economy

Size		CM Series	
Bore	Thread	Right Hand	Left Hand
10/32	10/32	QA1CMR3 \$2.35	QA1CML3 \$2.35
10/32	1/4	QA1CMR3-4 \$2.44	QA1CML3-4 \$2.44
1/4	1/4	QA1CMR4 \$2.44	QA1CML4 \$2.44
1/4	5/16	QA1CMR4-5 \$2.58	QA1CML4-5 \$2.58
5/16	5/16	QA1CMR5 \$2.72	QA1CML5 \$2.72
5/16	3/8	QA1CMR5-6 \$2.79	QA1CML5-6 \$2.79
3/8	3/8	QA1CMR6 \$2.90	QA1CML6 \$2.90
3/8	7/16		
7/16	7/16	QA1CMR7 \$3.61	QA1CML7 \$3.61
7/16	1/2	QA1CMR7-8 \$4.37	QA1CML7-8 \$4.37
1/2	1/2	QA1CMR8 \$4.29	QA1CML8 \$4.29
1/2	5/8	QA1CMR8-10 \$6.43	QA1CML8-10 \$6.43
1/2	3/4		
5/8	5/8	QA1CMR10 \$6.61	QA1CML10 \$6.61
5/8	3/4	QA1CMR10-12 \$8.31	QA1CML10-12 \$8.31
3/4	3/4	QA1CMR12 \$8.79	QA1CML12 \$8.79
3/4	.757	QA1CMR12-757 \$8.79	
3/4	7/8		



Aluminum Over 10% Lighter

Size		AM Series	
Bore	Thread	Right Hand	Left Hand
10/32	10/32	QA1AMR3 \$5.22	QA1AML3 \$5.22
1/4	1/4	QA1AMR4 \$5.39	QA1AML4 \$5.39
5/16	5/16	QA1AMR5 \$6.11	QA1AML5 \$6.11
5/16	3/8	QA1AMR5-6 \$8.90	QA1AML5-6 \$8.90
3/8	3/8	QA1AMR6 \$8.90	QA1AML6 \$8.90
3/8	7/16	QA1AMR6-8 \$10.26	QA1AML6-8 \$10.26
7/16	7/16	QA1AMR7 \$10.26	QA1AML7 \$10.26
7/16	1/2	QA1AMR7-8 \$12.31	QA1AML7-8 \$12.31
1/2	1/2	QA1AMR8 \$12.31	QA1AML8 \$12.31
1/2	5/8	QA1AMR8-10 \$12.63	QA1AML8-10 \$12.63
1/2	3/4		
5/8	5/8	QA1AMR10 \$15.04	QA1AML10 \$15.04
5/8	3/4	QA1AMR10-12 \$17.10	QA1AML10-12 \$17.10
3/4	3/4	QA1AMR12 \$17.10	QA1AML12 \$17.10

*Add BK for Black



Chromoly Steel Best for Racing



Size		XM Series	
Bore	Thread	Right Hand	Left Hand
10/32	10/32	QA1XMR3 \$7.66	QA1XML3 \$7.66
1/4	1/4	QA1XMR4 \$7.72	QA1XML4 \$7.72
5/16	5/16	QA1XMR5 \$7.86	QA1XML5 \$7.86
5/16	3/8	QA1XMR5-6 \$8.90	QA1XML5-6 \$8.90
3/8	3/8	QA1XMR6 \$8.90	QA1XML6 \$8.90
3/8	7/16	QA1XMR6-8 \$10.95	QA1XML6-8 \$10.95
7/16	7/16	QA1XMR7 \$10.95	QA1XML7 \$10.95
7/16	1/2	QA1XMR7-8 \$13.34	QA1XML7-8 \$13.34
1/2	1/2	QA1XMR8 \$13.34	QA1XML8 \$13.34
1/2	5/8	QA1XMR8-10 \$17.43	QA1XML8-10 \$17.43
1/2	3/4	QA1XMR8-12 \$25.32	QA1XML8-12 \$25.32
5/8	5/8	QA1XMR10 \$17.43	QA1XML10 \$17.43
5/8	3/4	QA1XMR10-12 \$25.32	QA1XML10-12 \$25.32
3/4	3/4	QA1XMR12 \$25.32	QA1XML12 \$25.32
3/4	7/8	QA1XMR12-14 \$30.69	QA1XML12-14 \$30.69



Chromoly Steel High Performance

Size		PCM Series	
Bore	Thread	Right Hand	Left Hand
10/32	10/32	QA1PCMR3 \$6.17	QA1PCLM3 \$6.17
10/32	1/4	QA1PCMR3-4 \$8.21	QA1PCLM3-4 \$8.21
1/4	1/4	QA1PCMR4 \$8.21	QA1PCLM4 \$8.21
1/4	5/16	QA1PCMR4-5 \$10.95	QA1PCLM4-5 \$10.95
5/16	5/16	QA1PCMR5 \$10.95	QA1PCLM5 \$10.95
5/16	3/8	QA1PCMR5-6 \$13.34	QA1PCLM5-6 \$13.34
3/8	3/8	QA1PCMR6 \$13.34	QA1PCLM6 \$13.34
3/8	7/16	QA1PCMR6-8 \$17.43	QA1PCLM6-8 \$17.43
7/16	7/16	QA1PCMR7 \$17.43	QA1PCLM7 \$17.43
7/16	1/2	QA1PCMR7-8 \$21.52	QA1PCLM7-8 \$21.52
1/2	1/2	QA1PCMR8 \$21.52	QA1PCLM8 \$21.52
1/2	5/8	QA1PCMR8-10 \$25.61	QA1PCLM8-10 \$25.61
1/2	3/4	QA1PCMR8-12 \$30.70	QA1PCLM8-12 \$30.70
5/8	5/8	QA1PCMR10 \$25.61	QA1PCLM10 \$25.61
5/8	3/4	QA1PCMR10-12 \$30.70	QA1PCLM10-12 \$30.70
3/4	3/4	QA1PCMR12 \$30.70	QA1PCLM12 \$30.70
3/4	.757	QA1PCMR12-757 \$30.70	
3/4	7/8		

*Add T for Teflon

Carbon Steel Economy

Size		CF Series	
Bore	Thread	Right Hand	Left Hand
10/32	10/32	QA1CFR3 \$2.35	QA1CFL3 \$2.35
10/32	1/4	QA1CFR3-4 \$2.44	QA1CFL3-4 \$2.44
1/4	1/4	QA1CFR4 \$2.44	QA1CFL4 \$2.44
1/4	5/16	QA1CFR4-5 \$2.72	QA1CFL4-5 \$2.72
5/16	5/16	QA1CFR5 \$2.72	QA1CFL5 \$2.72
5/16	3/8	QA1CFR5-6 \$2.90	QA1CFL5-6 \$2.90
3/8	3/8	QA1CFR6 \$2.90	QA1CFL6 \$2.90
3/8	7/16	QA1CFR7 \$3.61	QA1CFL7 \$3.61
7/16	7/16	QA1CFR7-8 \$4.29	QA1CFL7-8 \$4.29
1/2	1/2	QA1CFR8 \$4.29	QA1CFL8 \$4.29
1/2	5/8	QA1CFR8-10 \$6.61	QA1CFL8-10 \$6.61
1/2	3/4	QA1CFR8-12 \$8.79	QA1CFL8-12 \$8.79



Aluminum Over 10% Lighter

Size		AF Series	
Bore	Thread	Right Hand	Left Hand
10/32	10/32	QA1AFR3 \$5.27	QA1AFL3 \$5.05
1/4	1/4	QA1AFR4 \$5.44	QA1AFL4 \$5.44
5/16	5/16	QA1AFR5 \$6.16	QA1AFL5 \$6.16
5/16	3/8	QA1AFR5-6 \$8.97	QA1AFL5-6 \$8.97

*Add BK for Black



Chromoly Steel High Performance

Size		XF Series	
Bore	Thread	Right Hand	Left Hand
10/32	10/32	QA1XFR3 \$7.66	QA1XFL3 \$7.66
1/4	1/4	QA1XFR4 \$7.72	QA1XFL4 \$7.72
5/16	5/16	QA1XFR5 \$7.86	QA1XFL5 \$7.86
5/16	3/8	QA1XFR5-6 \$8.90	QA1XFL5-6 \$8.90
3/8	3/8	QA1XFR6 \$8.90	QA1XFL6 \$8.90
3/8	7/16	QA1XFR6-8 \$10.95	QA1XFL6-8 \$10.95
7/16	7/16	QA1XFR7 \$10.95	QA1XFL7 \$10.95
7/16	1/2	QA1XFR7-8 \$13.34	QA1XFL7-8 \$13.34
1/2	1/2	QA1XFR8 \$13.34	QA1XFL8 \$13.34
1/2	5/8	QA1XFR8-10 \$17.43	QA1XFL8-10 \$17.43
1/2	3/4	QA1XFR8-12 \$25.32	QA1XFL8-12 \$25.32



Com Series



Bore	Part	Price
3/8	QA1COM6	\$4.10
1/2	QA1COM8	\$3.96
5/8	QA1COM10*	\$4.44
3/4	QA1COM12	\$6.51

*Add T for Teflon



Aluminum Flanged Jam Nuts
Made out of 7075 Aluminum.

Aluminum	LH thread	RH thread
1/2"-3/4"	JAMFA008L	JAMFA008 \$1.00
5/8"-3/4"	JAMFA010L	JAMFA010 \$1.38
3/4"-15/16"	JAMFA012L	JAMFA012 \$1.22
1/2"-3/4"	JAMFA008LBK	JAMFA008BK \$1.33
5/8"-3/4"	JAMFA010LBK	JAMFA010BK \$1.33
3/4"-15/16"	JAMFA012LBK	JAMFA012BK \$1.54

Clevis

Size		Clevis	
Bore	Thread	Right Hand	Left Hand
1/4	5/16	QA1CR4-5 \$4.18	QA1CL4-5 \$4.18
5/16	5/16	QA1CR5-5 \$4.18	QA1CL5-5 \$4.18
5/16	3/8	QA1CR5-6 \$4.18	QA1CL5-6 \$4.18
5/16	1/2	QA1CR5-8 \$4.60	QA1CL5-8 \$4.60
3/8	1/2	QA1CR6-8 \$4.60	QA1CL6-8 \$4.60
3/8	5/8	QA1CR6-10 \$5.86	QA1CL6-10 \$5.86
3/8	3/4	QA1CR6-12 \$5.86	QA1CL6-12 \$5.86
7/16	1/2	QA1CR7-8 \$5.86	QA1CL7-8 \$5.86
7/16	5/8	QA1CR7-10 \$5.86	QA1CL7-10 \$5.86
1/2	5/8	QA1CR8-10 \$5.86	QA1CL8-10 \$5.86
5/8	3/4	QA1CR8-12 \$5.86	QA1CL8-12 \$5.86



Standard Jam Nuts
High quality cadmium plated steel or aluminum jam nuts for locking rod ends on steering, radius rods, 4-links, etc.

Steel	LH thread #	RH thread #
1/4"-28	JAM004L \$0.29	JAM004 \$0.21
5/16"-24	JAM005L \$0.42	JAM005 \$0.32
3/8"-24	JAM006L \$0.37	JAM006 \$0.21
7/16"-20	JAM007L \$0.53	JAM007 \$0.42
1/2"-20	JAM008L \$0.65	JAM008 \$0.55
5/8"-18	JAM010L \$0.85	0.85 \$0.85
3/4"-16	JAM012L \$1.10	JAM012 \$0.65
1/2"-20	JAM008LA \$0.77	JAM008A \$0.77
1/2"-20 Black	JAM008LABK \$1.21	JAM008A BK \$1.32
5/8"-18	JAM010LA \$0.88	JAM010A \$0.88
5/8"-18 Black	JAM010LABK \$1.38	JAM010A BK \$1.54
5/8"-18 Red	JAM010LARD \$1.74	JAM010A RD \$1.74
3/4"-16	JAM012LA \$1.05	JAM012A \$1.05
5/8"-18 x 3/4"	JAM010L-3/4 \$0.94	JAM010-3/4 \$0.94
5/8"-18 x 3/4"	JAM010LA-3/4 \$0.94	JAM010A-3/4 \$0.94
5/8"-18 x 3/4" Bk	JAM010LA-3/4BK \$1.32	JAM010A-3/4BK \$1.32
5/8"-18 x 3/4" Red	JAM010LA-3/4RD \$1.58	JAM010A-3/4RD \$1.58



Aluminum Hex Suspension Tubes
Used in steering and suspension systems, hex tubes are easy to install and adjust. Available in 7/8" hex with 5/8" threads tapped RH and LH, and 1-1/8" hex with 3/4" threads tapped RH & LH, tubes are black anodized for appearance & corrosion resistance.

Size	5/8" Thread	16"	17"	18"	19"	20"	21"	22"
7"	ALL56607	\$10.99	ALL56616	\$12.99	ALL56617	\$12.99	ALL56618	\$14.79
8"	ALL56608	\$10.99	ALL56619	\$14.79	ALL56620	\$14.79	ALL56621	\$14.79
9"	ALL56610	\$11.29	ALL56622	\$14.79	ALL56623	\$14.79	ALL56624	\$14.79
10"	ALL56611	\$11.29	ALL56625	\$14.79	ALL56626	\$14.79	ALL56627	\$14.79
11"	ALL56612	\$12.99	ALL56628	\$14.79	ALL56629	\$14.79	ALL56630	\$14.79
12"	ALL56613	\$12.99	ALL56631	\$12.99	ALL56632	\$12.99	ALL56633	\$12.99
13"	ALL56614	\$12.99	ALL56634	\$12.99	ALL56635	\$12.99	ALL56636	\$12.99
14"	ALL56615	\$12.99	ALL56637	\$12.99	ALL56638	\$12.99	ALL56639	\$12.99
15"	ALL56616	\$12.99	ALL56640	\$12.99	ALL56641	\$12.99	ALL56642	\$12.99

RADIUS RODS



Radius Rods / Panhard Bars

Hi-strength polished aluminum in 1" or 1/4", tapered 5/8" left and right threads. Use as radius rods, drag links, panhard bars, 4-link bars, or tie rods.

1" Radius Rods

5.5"	RAD0055M	\$11.85
7"	RAD0070M	\$12.12
8"	RAD0080M	\$12.38
9"	RAD0090M	\$12.65
10"	RAD0100M	\$12.92
11"	RAD0110M	\$13.18
12"	RAD0120M	\$13.69
13"	RAD0130M	\$13.71
14"	RAD0140M	\$13.98
14.5"	RAD0145M	\$14.25
15"	RAD0150M	\$14.25
15.5"	RAD0155M	\$14.51
16"	RAD0160M	\$14.51
16.5"	RAD0165M	\$14.78
17.0"	RAD0170M	\$14.78
17.5"	RAD0175M	\$15.05
18"	RAD0180M	\$15.05
18.5"	RAD0185M	\$15.31
19"	RAD0190M	\$15.31
19.5"	RAD0195M	\$15.58
20"	RAD0200M	\$15.58
20.5"	RAD0205M	\$15.85
21"	RAD0210M	\$15.85
21.5"	RAD0215M	\$15.85
22"	RAD0220M	\$16.11
22.5"	RAD0225M	\$16.38
23"	RAD0230M	\$16.38
23.5"	RAD0235M	\$16.65
24"	RAD0240M	\$16.65
24.5"	RAD0245M	\$16.91
25"	RAD0250M	\$16.91
25.5"	RAD0255M	\$17.18
26"	RAD0260M	\$17.18
26.5"	RAD0265M	\$17.45
27"	RAD0270M	\$17.45
27.5"	RAD0275M	\$17.71
28"	RAD0280M	\$17.71
28.5"	RAD0285M	\$17.98
29"	RAD0290M	\$17.98
29.5"	RAD0295M	\$18.25
30"	RAD0300M	\$18.25

1-1/4" Radius Rods

14.5"	RAD1145M	\$19.68
15"	RAD1150M*	\$19.68
17"	RAD1170M*	\$20.66
17.5"	RAD1175M*	\$21.16
18"	RAD1180M*	\$21.16
18.5"	RAD1185M*	\$21.65
19"	RAD1190M	\$21.65
19.5"	RAD1195M	\$22.14
20"	RAD1200M	\$22.14
21"	RAD1210M	\$22.63
22"	RAD1220M	\$23.12
23.5"	RAD1235M	\$24.11
24"	RAD1240M	\$24.11
24.5"	RAD1245M	\$24.60
25"	RAD1250M	\$24.60
25.5"	RAD1255M	\$25.09
26"	RAD1260M	\$25.09
26.5"	RAD1265M	\$25.58
27"	RAD1270M	\$25.58
27.5"	RAD1275M	\$26.08
28"	RAD1280M	\$26.08
28.5"	RAD1285M	\$26.57
29"	RAD1290M	\$26.57
30"	RAD1300M	\$27.06
30.5"	RAD1305M	\$27.55
32"	RAD1320M	\$28.04
33"	RAD1330M	\$30.59
33.5"	RAD1335M	\$31.08
45.5"	RAD1455M	\$36.98
46"	RAD1460M	\$36.98
46.5"	RAD1465M	\$37.47
47"	RAD1470M	\$37.47
47.5"	RAD1475M	\$37.97
48"	RAD1480M	\$37.97
48.5"	RAD1485M	\$38.46
49"	RAD1490M	\$38.46
49.5"	RAD1495M	\$38.95
62"	RAD1620M	\$44.85
64"	RAD1640M	\$45.84
64.5"	RAD1645M	\$46.33
65"	RAD1650M	\$46.33
65.5"	RAD1655M	\$46.82
66"	RAD1660M	\$46.82
66.5"	RAD1665M	\$47.31
67"	RAD1670M	\$47.31
67.5"	RAD1675M	\$47.81
68"	RAD1680M	\$47.81
68.5"	RAD1685M	\$48.30

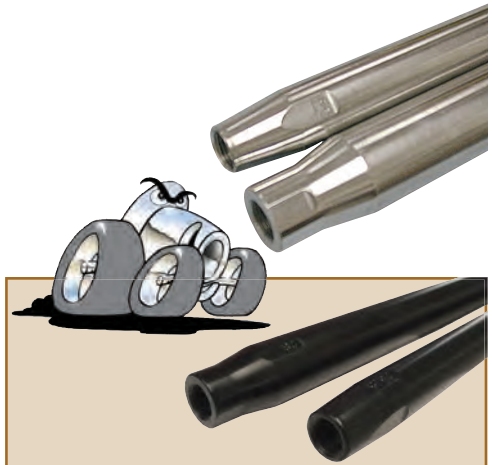

Black 1" Radius Rods

14.5"	RAD0145BK	\$18.86
15.0"	RAD0150BK	\$18.86
21"	RAD0210BK	\$20.46
21.5"	RAD0215BK	\$20.46
24.5"	RAD0245BK	\$21.53
25"	RAD0250BK	\$21.53
25.5"	RAD0255BK	\$21.79
26"	RAD0260BK	\$21.79

Black 1-1/4" Radius Rods

14.5"	RAD1145BK	\$24.29
14.5" (3/4)	RAD1145BK-3/4	\$24.29
15.0"	RAD1150BK	\$24.29
15.0" Teo PH 3/4 x 5/8	RAD1150BKR	\$24.29
17.5"	RAD1175BK	\$25.77
17.5" Spring Rod 3/4 x 5/8	RAD1175BKs	\$25.77
17.5" Spring Rod 5/8 x 5/8	RAD1175BKs-5/8	\$25.77
18.0"	RAD1180BK	\$25.77
18.0" Spring Rod 3/4 x 5/8	RAD1180BKs	\$25.77
18.5" (3/4)	RAD1185BK-3/4	\$25.85
18.5" Spring Rod 3/4 x 5/8	RAD1185BKs	\$26.26
24.5"	RAD1245BK	\$29.21
25.0"	RAD1250BK	\$29.21
27.5"	RAD1275BK	\$30.69
28"	RAD1280BK	\$30.69
47"	RAD1470BK	\$58.49
47.5"	RAD1475BK	\$58.98
48"	RAD1480BK	\$58.98
48.5"	RAD1485BK	\$59.47
64"	RAD1640BK	\$66.85



ABS Anti Bind Radius Rod System

Get rid of front end hidden bind.

24.5"	TEOT040	\$113.10
25"	TEOT04025	\$113.10

Replacement Parts

25" Rod Only	TEOT04025A	\$31.20
Radius Rod Only	TEOT040A	\$31.20
RR Housing	TEOT040B	\$39.00
RR Bolt	TEOT040C	\$18.20
RR End Cap	TEOT040D	\$20.15

BRP9099L



Radius Rod Adapter Mount

(Shortens Radius Rod by 2")
LeftBRP9099L ...\$51.28
RightBRP9099R ..\$51.28



Standard Jam Nuts for Radius Rods

High quality cadmium plated steel or aluminum jam nuts for locking rod ends on steering, radius rods, 4-links, etc.

Steel	LH thread #	RH thread #
5/8"-18	JAM010L \$0.85	0.85 \$0.85
Aluminum	LH thread #	RH thread #
5/8"-18	JAM010LA \$0.88	JAM010A \$0.88
5/8"-18 Black	JAM010LA BK \$1.54	JAM010A BK \$1.54
5/8"-18 Red	JAM010LA RD \$1.74	JAM010A RD \$1.74



Chassis Brackets

3/16" Tab2-3/4" Height.....No Hole 4 Pack	ALL60000 ...	\$12.49
3/16" Tab2-3/4" Height.....3/8" Hole 4 Pack.....	ALL60001 ...	\$12.49
3/16" Tab2-3/4" Height.....1/2" Hole 4 Pack.....	ALL60002 ...	\$12.49
0.125" Tab2" Height.....1/4" Hole 4 Pack.....	ALL60003 ...	\$9.99



Universal Flat Tabs

3/16" Tab1.825" Height.....1/2" Hole 4 Pack.....	ALL60006 ...	\$9.99
1/4" Tab2" Height.....3/8" Hole 4 Pack.....	ALL60007 ...	\$12.99
1/4" Tab2" Height.....1/2" Hole 4 Pack.....	ALL60008 ...	\$12.99
1/8" Tab1-1/2" Height.....1/4" Hole 4 Pack.....	ALL60009 ...	\$8.99



Radius Tabs

1-1/4 Radius

1/8" Tab1-1/2" Height.....1/4" Hole 4 Pack.....	ALL60010 ...	\$6.99
1/8" Tab1-1/2" Height.....3/8" Hole 4 Pack.....	ALL60011 ...	\$6.99



Gusset Tab

1-1/2 Radius

1/8" Tab2.050" Height.....3/8" Hole 4 Pack.....	ALL60016 ...	\$12.79
---	--------------	----------------



Seat Tab

.187" Tab2-3/8" Height.....1/2" Hole 4 Pack.....	ALL60018 ...	\$4.89
.250" Tab2-3/8" Height.....1/2" Hole 4 Pack.....	ALL60019 ...	\$4.89



16 Gauge Window Frame

1" x 1" Steel.....10 Pack.....	ALL60020 ...	\$11.29
3/4" x 3/4" Steel.....10 Pack.....	ALL60021 ...	\$10.99



Bumper Tab .937" Flat to Center of Hole

1/4" Tab, 1-1/4" Long.....1/4" Hole 4 Pack.....	ALL60022 ...	\$9.89
---	--------------	---------------



Rub Rail Flange Tab 3/8" Small Holes, 2-1/4" between center of holes

3/16" Tab, 1-1/4" Dia Hole.....4 Pack.....	ALL60023 ...	\$14.99
--	--------------	----------------



Bell Crank Tab

.085" Tab1.550 Height.....3/8" Hole 4 Pack.....	ALL60024 ...	\$7.99
---	--------------	---------------



Brake Line Adapter Tab

Bolt-On Tab.....2 Pack.....	ALL60029 ...	\$8.99
Weld-On Tab 1-1/4 Height......650" Hole 4 Pack.....	ALL60030 ...	\$5.99



Double Shear Seat Belt Bracket

Double Shear Seat Belt Bracket.....1 Pack.....	ALL60031 ...	\$7.99
--	--------------	---------------



Seat Belt Mount Backing Plates

Seat Belt Mount Backing Plates.....2 Pack.....	ALL98120 ...	\$6.99
--	--------------	---------------



Economy Ballast Brackets

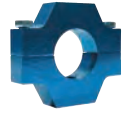

Brackets are tapped with a 1/2"-13 hole for ballast mounting stud. Stud and nut sold separately.

ALL14195 1-1/2", Round ..	\$10.49
ALL14197 1-3/4", Round ..	\$10.49

Ballast Brackets

Alum brackets have a 1/2"-13 tapped hole for a ballast mounting stud. Stud and nut sold separately.



ALL14178 .1.00", Round...	\$12.99
ALL14183 .1.250", Round...	\$12.99
ALL14185 .1.500", Round...	\$12.99
ALL14187 .1.750", Round...	\$12.99



Ballast Mounts



1" Round.....	BRP5113 ..	\$22.07
1-1/8" Round.....	BRP5114 ..	\$22.07
1-1/4" Round.....	BRP5115 ..	\$22.07
1-1/2" Round.....	BRP5117 ..	\$22.07
1-3/4" Round.....	BRP5119 ..	\$22.07

1 1/2"x 1-1/2" Sq ..	BRP5121 ..	\$22.07
2"x 2" Square	BRP5122 ..	\$22.07
2"x 2-1/2" Square	BRP5123 ..	\$22.07



Rear Coil Spring Seat

Mounts coil spring to tube axle.
AFC20156.....**\$29.99**



Solid Trans Mount, Chevy



Sturdy mount is constructed from 3/16" steel and features slotted holes on top for trans mounting and threaded nuts welded to bottom for crossmember mounting. Black zinc finish. NOTE: Solid Trans Mounts must be used in conjunction with Solid Motor Mounts to prevent breakage of engine block and trans case due to torsional stress. 58-'88 Chevy except 82-'92 Camaro/Firebird, fits Powerglide, TH-350, TH-400, and all Borg-Warner, Muncie, Saginaw, Chrysler 4-Speed and Doug Nash 5-Speed trans.

MOR62600.....	\$28.10
---------------	----------------

Solid Motor Mount Pad Kits, Chevy

It replace soft rubber-cushioned frame mts supplied as OEM equipment on 74-'97 Camaro/Firebirds & other GM vehicles. Control excessive engine movement, prevent linkage binding & eliminate the need for torque straps. 2 per package. Zinc & yellow chromate plating. 74-81' Camaro/Firebird; 73-88' Chevelle, Malibu, El Camino, Monte Carlo; 73-79' Nova; 76-90' Impala, Caprice; Small Block, use with Moroso Steel Motor Mts MOR62515

MOR62630.....	\$57.14
---------------	----------------

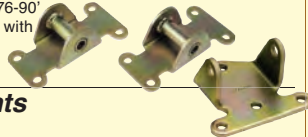

Chevrolet Motor Mounts

Zinc plated steel.		
.250" Replaces OEM #3990914	MOR62500 ..	\$34.87
.188" Replaces OEM #3962748	MOR62510 ..	\$31.41
.188" Replaces OEM #332648 when used w/62630	MOR62515 ..	\$31.14
.188" Replaces OEM #6258154	MOR62530 ..	\$32.08

Available Option: Chrome plated Bolt Kit MOR38721

Chevy Motor Mount Fabricated Chassis

Designed primarily for oval track or any fabricated chassis application. (They do not fit any particular OEM chassis). Allows for quick, easy engine removal and reinstallation. Manufactured from .250" thick steel with zinc plating to resist corrosion. 2 per package.

.250" zinc plated steel, SBC, BBC & 90" Chevy V6 in fab chassis	
MOR62550.....	\$24.62



Chevy LS Series Motor Mount Adapter Plates

Simple and efficient way to adapt motor mounts to fit LS Series Engines. Manufactured from 6061 T-6 Aluminum Black anodized finish resists corrosion. Works with G.M. Factory 3-Bolt Mounts and Moroso Solid Motor Mounts MOR62500, MOR62510, MOR62515 and MOR62530. 2 per pack, with hardware. Made in USA.

MOR62555.....	\$88.01
---------------	----------------





Inner Bushings

Bushings mount on the inside end of a strut-style lower control arm and act as a spacer between each side of the 3/4" inner rod end and the crossmember. Sold in packs of two.



Cross Member (2-Pack)ALL56188\$6.99

Spacer Kits

Spacer Kits for UMP Tubular Lower Control Arms



'68-72 Chevelle, 4pcs..ALL56322 ...\$12.99
'68-74 Nova, 5pcs.ALL56325 ...\$13.99

Steel and Aluminum Clevises

3/4" clevises attach strut rod to A-frame (3/4" x 16 with a .500" hole).
5/8" clevises, commonly used with Lefthander style upper A-frames, connect to Ball Joint holder (5/8" x 18 with a .385" hole).



3/4" RH Steel Clevis.....ALL56192\$10.49
3/4" RH Aluminum ClevisALL56193\$11.99
5/8" RH ClevisALL56194\$14.29



Upper A-Arm Brackets

Stamped steel, 3/16" thick mild steel brackets weld to chassis, providing a mounting point for upper control arm. Brackets are sold in pair sand have two 5/8" mounting holes, spaced 7/8" apart for additional adjustment. May be trimmed to desired height.



Upper A-Arm Bkts.....ALL60025.....\$6.99

Upper A-Arm Mount

Mount is flame cut from 1/2" thick steel, with a 6" bolt spacing. Welds to frame and accepts upper A-frame.



4 Hole Upper A-Arm Mt.....ALL60190\$13.79

Upper Control Arm Shims

Shims allow easy adjustment of caster/camber during front end alignment. Available in various thicknesses.



0.0625" Individual, 10-Pack.....ALL60200\$6.59
0.125" Individual, 10-Pack.....ALL60201\$6.79
0.125" Dual Mount, 1-Piece.....ALL60203\$8.49
0.185" Dual Mount, 1-Piece.....ALL60204\$8.69
0.250" Dual Mount, 1-Piece.....ALL60205\$8.89
0.375" Dual Mount, 1-Piece.....ALL60206\$9.99
0.500" Dual Mount, 1-Piece.....ALL60207\$10.49
0.750" Dual Mount, 1-Piece.....ALL60208\$12.99
1.000" Dual Mount, 1-Piece.....ALL60209\$14.39
A-Arm Shim Kit, Includes ALL60203-60209
One of each sizeALL60210\$64.99

Metric Spindle Savers

Stamped steel spindle savers reinforce the steering arm portion of GM Metric spindles to make them suitable for wheel-to-wheel racing. IMCA-legal and easily installed, spindle savers are retained by the lower ball joint and tie rod end retaining nuts. Sold in pairs.



ALL42130.....\$15.99

Fine 1-1/8"-12 Thread Jack Bolt Collar

Steel collar measures 1-3/8" tall x 1-5/8" dia. and welds onto frame. Complete with grease fitting. 1-1/8" -20 Thread.



ALL56098.....\$9.99

Bolt-On Upper Spring Plates

Bolts to internal thread jack bolts. Keeps spring centered to the jack bolt.



"Swiveler" Spring Cups

Used with conventional coil springs, this mono-ball and stud helps eliminate binding between the spring cup and stud. The stud threads into jack bolts with an internal thread (Allstar ALL56090). Two styles available: Welded Style, where spring sleeve is welded to the plate, and Pro-Series with bolt-on spring sleeves to accommodate various spring diameters and rates.

Welded Style Swiveler Spring Cup 3.25" OD

ALL56080\$46.99
Replacement Spring Sleeve
3.25" OD.....ALL56086\$10.49
3.50" OD.....ALL56087\$10.49
3.75" OD.....ALL56088\$13.49



3" Coil Spring Spacer

Steel spacers are used with conventional coil springs. May be shortened to required length.



ALL56116\$17.99

Coil Spring Shims

Used with #ALL56116, or whenever weight jack bolts are not allowed, to raise car height for set-up purposes. 5" diameter, 3-5/8" I.D.



3/16".....ALL56120\$5.99
1/8".....ALL56121\$5.69

Adj. Spring Spacer

Spacer adapts racing front springs for use on street stock cars where weight jack bolts are not allowed.

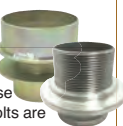

All Steel Assembly.....ALL56118\$39.99
Steel Sleeve with Alum. Adj. Nut.....ALL56119\$41.99

Rear Lower Spring Plate

Welds to 3" dia rear end tube and works with conventional-style 5" coil springs. Length is 7". Sold individually.



ALL56124.....\$11.29

Weight Jack Bolts w/ Internal Thread

Bolts feature an internal thread, 7/16" -20, on one end for use with bolt-on and swiveler spring cups. Fine thread bolts have 1-1/8" -20 outer threads, while coarse thread bolts are 1"-8. Available in steel or aluminum.



6" Aluminum, Fine ThreadALL56090\$15.99
8" Aluminum, Fine ThreadALL56091\$15.99
6" Steel, Fine ThreadALL56092\$14.99
8" Steel, Fine ThreadALL56093\$14.99
4" Steel, Coarse ThreadALL56094\$11.99
6" Steel Coarse ThreadALL56095\$11.99

Clamp-On Lower Spring Pad

Steel clamp-on leaf spring pad fits 3" dia axle tubes. Perch measurements are similar to ALL56126. Sold individually.



ALL56127\$29.99

Leaf Spring Perch

Welds to 3" diameter rear end housing and works with most leaf springs. Sold individually.



ALL56126\$6.99



Rear Axle Spring Perch, 2-1/2" Wide

Fits: Ford 9", Dana 60 and other 3" diameter axle housings. Precision stamped for easy weld-on installation. Two per package.



Rear Axle Spring Perches, 2-1/2" Wide
MOR85090\$23.63

Aluminum Lowering Blocks

Easily adjust ride height on leaf spring type cars. Standard and adjustable styles, sold individually.

Extruded Aluminum

Width/Length: 2-1/2" x 5" - Pin Dia.: 6/16"
1" Height.....ALL56130\$10.49
1-1/2" Height.....ALL56131\$11.49
2" Height.....ALL56132\$12.69
2-1/2" Height.....ALL56133\$13.99
3" Height.....ALL56134\$14.99



Billet Aluminum

Width/Length: 2-1/2" x 5" - Pin Dia.: 5/8"
3/4" Height.....ALL56060\$23.99
1" Height.....ALL56061\$24.99
1-1/2" Height.....ALL56062\$25.99
2" Height.....ALL56063\$29.99
2-1/2" Height.....ALL56064\$31.99
3" Height.....ALL56065\$32.99



Width/Length: 2-1/4" x 5" - Pin Dia.: 5/8"
1-1/2" Adj Height.ALL56136\$38.99
2-1/2" Adj Height.ALL56138\$38.99

U-Bolt Pads

Designed for use on 3" dia. axle tubes, Allstar Perf. U-Bolt pads have a provision for a single shock mount.



Right U-Bolt Pad.....ALL60036\$23.99
Left U-Bolt PadALL60037\$23.99
Dual Mount Pad.....ALL60038\$24.99

Leaf Spring Slider Box

It replaces conventional leaf spring shackles to enable effortless suspension movement and prevent binding. May be welded, or bolted directly to chassis. Includes two nylon bushings.



Leaf Spring Slider BoxALL60034\$19.59
Replacement BushingsALL99055\$11.49

Coil-Over Load Bolt Assembly

Threaded bolt is 6" long with 1-1/8"-12 fine threads and is commonly used on big bar soft spring cars. Load bolt offers the ability to easily change corner weights, change the center to center distance of the shock, adjust bump stop distances without adding shims and adjust ride height without running out of shock travel. Commonly used with ALL56098 threaded sleeve.

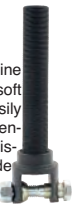

ALL56074\$44.99

Weight Jack Bolt Sleeves

Weld-in mild steel sleeve provides a mounting point for jack bolts or adjustable shock mounts. Sleeves are 2" long and have a 1-3/8" O.D. for welding into chassis tubing.



ALL56073\$11.99

Weight Jack Plate

Heavy-duty steel plate has a threaded boss welded to the center to accept jack bolts with 1" coarse threads. O.D. is 5".



ALL56112\$7.79

Upper Spring Plates

Use Steel Upper Spring Plates with conventional coil springs and most common weight jack bolts.



Upper Spring PlateALL56114\$9.99
Oversize Spring Plate.....ALL56115\$12.39





Engine Lift Plate For LS Series GM Engines

Designed specifically for LS series GM engines. Must remove intake manifold and valley cover tray to properly secure lift plate to engine block. Use existing valley cover tray bolts to ensure the correct size bolt is inserted into the bolt holes of the engine block. Three laser cut holes for various chain placements allow engine weight to be balanced or offset. An offset position is especially helpful when angling an engine (with trans attached) in or out of a vehicle. Constructed of 1/8" thick zinc plated steel.

ALL10140 ..\$59.99

Ford Engine Lift Plate

Ease engine swaps with the Allstar Engine Lift Plate. Fits standard 5.0L/5.8LEFI Intakes: OEM, GT-40, Cobra, Holley, Edelbrock.

ALL10125 ..\$55.99

Engine Cradles

They are available in Standard Duty or Heavy Duty, both with provisions for mounting wheels. Made of 1" square tubing with black powder coating. Stands include Grade 5 fasteners and may be easily disassembled for storage. Standard Duty cradles accept wheel kits with 3/8" studs. Heavy Duty cradles accept wheel kits with 1/2" studs. Wheel kits must be purchased.

- SBC/BBC Std DutyALL10130\$59.99
- SBC/BBC Heavy DutyALL10132\$74.99
- GM LS Series Std DutyALL10138\$79.99
- GM LS Series Heavy DutyALL10139\$84.99
- Oldsmobile Heavy DutyALL10142\$81.99
- Pontiac Heavy DutyALL10144\$74.99
- SBF Std DutyALL10145\$74.99
- SBF Modular V8 Std DutyALL10147\$78.99
- SBF Heavy DutyALL10148\$74.99
- SBF Modular V8 Heavy DutyALL10149\$83.99
- SBM Heavy DutyALL10152\$76.99
- BBF Heavy DutyALL10154\$77.99
- BBM Heavy DutyALL10156\$76.99

Sprint Engine Cradle

Cradle bolts to most stock type and aftermarket SBC blocks, including narrow pattern light-weight, and standard bell housing bolt patterns. Slotted front mounts accept most frame width engine mounts. Provisions for standard wheel kits are positioned to support complete engines with attached radiators.

ALL10159 ..\$81.99

Cradle Wheel Kits

Hard rubber wheel kits may be mounted to Allstar engine cradles ALL10130 thru ALL10156. Kits are also available with locking wheels, ideal for storing spare engines in race trailer. Standard duty kits feature 3/8" studs and heavy duty models use 1/2" studs. Four wheels per kit.

- 3" Wheel Kit-Std DutyALL10162...\$29.99
- 3" Locking Wheel Kit-Std DutyALL10163...\$36.99
- 3" Wheel Kit-Heavy DutyALL10164...\$48.99
- 3" Locking Wheel Kit-Heavy DutyALL10165...\$51.99
- 5" Wheel Kit-Heavy DutyALL10166...\$66.99

Clamp-On Rings

Steel brackets bolt to 3" diameter axle tubes.

ALL60145...\$11.99

Side Grip Cleco Fastener

A very strong spring clamp to hold pieces together when drilling is not an option. The smooth throat prevents paint damage and is 1" deep with a max clamping range of 1/2". Works with ALL18220 Cleco pliers.

ALL18230 ..\$3.99

Heel Riser

Alum heel riser is pre-drilled for easy mounting and includes a non-skid pad. 1" tall x 4-1/2" wide.

ALL54090 ..\$15.99

Chevy Solid Motor Mount

Solid Motor Mounts are 1/4" thick steel and replace stock Chevy mounts to eliminate the torque loss and excessive engine movement associated with stock rubber mounts. Sold individually.

ALL38080 ..\$11.99

SBC Raised Motor Mounts

Use these mounts to raise the engine in the chassis instead of spacers and longer bolts. Use when changing from a dry sump to a wet sump engine when extra clearance is required. 1" or 1-1/2" raised mounts are 1/4" steel and slotted for easy installation.

Front Mount, Raised 1"ALL38060...\$15.99

Front Mount, Raised 1-1/2".....ALL38061...\$15.99

Rear Mount, Raised 1".....ALL38064....\$15.49

Rear Mount, Raised 1-1/2".....ALL38065....\$15.49

Motor Mount Pad

Ideal for building custom motor mounts or adding mount pads to homemade engine stands. Sold per pair.

Motor Mount Pad (Pair)
ALL38090.....\$14.99

Solid

Transmission Mt

Solid 3/16" steel mount fits most TH350, TH400, Powerglide, and all Borg Warner, Muncie, and Chrysler 4-speed trans. Mount eliminates unwanted twisting, flex, and distortion under racing conditions. Not recommended for use with rubber engine mounts.

ALL38070 ..\$19.99

Transmission Mt Bracket

May be welded to chassis to support manual or automatic transmissions. Steel bracket is 1/8" thick with 1" x 7/16" slots for mounting bolts.

ALL38072 ..\$14.59

Transmission

Supports For Bert

Transmission supports fasten to the rear tail shaft housing of Bert Late Model Standard and Ball Spline transmissions adding support to bellhousing mounted dry sump oil pumps or directly to the chassis. Multiple holes in brackets offer many different support options.

Trans. Support, Bert With Standard Tailhousing
ALL38075 ..\$24.99

Trans. Support, Bert With Ball Spline
ALL38076 ..\$24.99

In-Line Duct Blowers

Many uses include cooling brake systems or assisting helmet cooling efforts. CFM ratings at 13.6 volts with a 3.5 amp draw.

3" Heavy Duty Inline Blower, 8" Long
170 CFMALL13008\$24.99

240 CFMALL13009\$23.99

3" Compact Inline Blower, 5" Long
140 CFMALL13010\$27.99

Hub Bearing Kits

Kits contain inner bearing, outer bearing and seal.

Wide 5 Bearing Kit, Wilwood, Sierra, Winters
ALL72300\$22.49

Wide 5 Bearing Kit, Howe
(Contender Hub Only)
ALL72301\$23.49

5 x 5 Bearing Kit, Allstar, Howe, PCR
ALL72302\$23.49

5 x 5 Bearing Kit, SPC Rear
ALL72303\$42.99

90/10 Shock Bkts

Weld bkts to the chassis, then mt shock between the chassis and the differential to control "unloading" during deceleration or hard braking. Bkts fit 1-1/2" dia. tubing and have four 1/2" holes, spaced 1" apart. Sold in pairs.

ALL60026.....\$8.49



Motor Mounts For SBC

Front motor mts are available in std centered, or 1", 2", & 3-3/8" offsets. Rear motor mts are available with a tab welded on, or in kit form allowing the tab to be welded on at any location or angle. All motor mts are made from 1/4" thick steel.

Front Motor Mt (1)ALL38100 ..\$8.99

Rear Motor Mt (1).....ALL38101 ..\$11.99

Front Motor Mt, Unwelded (1).....ALL38102 ..\$9.99

Front Motor Mt, 1" Offset (Pair).....ALL38108 ..\$23.99

Front Motor Mt, 2" Offset (Pair).....ALL38109 ..\$23.99

Front Motor Mt, 3-3/8" Offset (Pair).ALL38110 ..\$26.99

Mid Plate SB Ford 5/8"

Allstar engine mid-plates are CNC machined from 1/4" thick 6061-T6 alum, to be lw and strong. Excess material has been removed, weight is less than 4 lbs. Dual mounting holes allow engine to be raised 1" in the chassis. Plates are powder coated in black to be good looking and durable. Fits Dirtworks and other chassis. Weight 3.6 lbs.

ALL38133...\$85.99

Polished Motor Mounts

Universal mounts work with existing chassis brackets and come with urethane bushings to isolate engine vibrations from the chassis.

ALL38106.....\$149.99

Aluminum Shifter Assemblies

LW anodized alum shifters include with 3/8" rod ends, lock-nuts, & rods. Shifter rods are tapped for right & left hand 3/8" rod ends. Shifter arms must be ordered separately.

1 Lever Shifter - Gold.....ALL54108\$64.99

2 Lever Shifter - Gold.....ALL54110.....\$69.99

3 Lever Shifter - Gold.....ALL54112.....\$91.99

Aluminum Shifter Arm.....ALL54118.....\$6.99

2 Lever Shifter - Black.....ALL54120.....\$69.99

2 Lever Shifter - Red.....ALL54121.....\$69.99

2 Lever Shifter - Purple...ALL54122.....\$69.99

Two Lever Shifter With Lock

Black anodized shifter has a built-in lock which holds the transmission into gear when track conditions are rough. Shifter includes one 16" long x 3/8" shifter rod, one 24" long x 3/8" shifter rod, 3/8" rod ends, and hardware.

ALL54125 ..\$84.99

Steel Quick Pins

Steel quick pins have three holes and are available with or without a built-in shoulder. ALL60108 fits Allstar coil-over brackets without using a separate bushing. ALL60109 is commonly used with non-bushing type brackets but will fit Allstar brackets using a separate bushing.

Pin With ShoulderALL60108...\$7.99

Positive Cam Lock Shifter

It is engineered to stay in gear and not jump out. CNC-machined billet aluminum shifter clamps to the frame on driver's right side. Includes all steel hardware, heavy duty cable, and quick release end for easy rear end changes.

ALL54135 ..\$156.99

Positive Lock Shift Cable

Shift cable is designed to be used with position lock type shifters to engage rear end of most sprint cars. 43" long with 10/32" threaded ends. Shift cable is sold less rod end. Use Aurora AURCW-3.

ALL54142 ..\$41.99



Floor Mount Gas Pedal

BSC introduces their Floor mount gas pedal. It is lightweight with safety toe return. It easily bolts on the floor for many different applications.
BSC90501.....\$49.95



T-Handle Shifter Cable

Shift cable locks in position with a twist of the handle to engage rear end of most sprint cars. 47" long with 10/32" threaded end. Shifter cable is sold less rod end. Use Aurora AURCW-3.
ALL54140 ..\$39.99



Adjustable Gas Pedals

Fully adjustable gas pedals are available for straight or angled foot box panels. Bronze bushings and nylon rollers provide smooth operation. Linkage arm has .250" diameter holes spaced every 1/2" for adjustment of throttle linkage. Aluminum construction.

StraightALL54098\$129.99
Angled.....ALL54099\$129.99



Gas Pedal

Unique gas pedal assemblies allow driver to pull them back if throttle sticks. Flat design allows mounting through the foot box or to brackets on dash bar. A roller style gas pedal, designed by renowned racer Brian Birkhofer, is also available and uses a nylon roller for smooth throttle control and has multiple linkage holes for adjustment.

Foot Box Mt Std. Gas Pedal.....ALL54100...\$19.99
Foot Box Mt Roller Style Gas Pedal...ALL54101...\$65.99
Firewall Mt Gas Pedal.....ALL54107...\$27.99



Sprint Throttle Pedal Assembly

LW, yet rugged alum pedal assembly, which may be mounted to the floor pan or lower frame rail, provides smooth, safe throttle control. Includes return spring bkt & fasteners. Weighs just 1/2 lb.
ALL54106 ..\$49.99



Spindle Checker Tools

Assure correct alignment of the upper and lower ball joint when checking for bent spindles. Kits fit most popular spindles with common 1-1/2" taper per foot upper ball joints (ALL56214) and GM (ALL56206) or Chrysler (ALL56216) style lower ball joints.

Spindle Checker Kit With GM Lower...ALL11176...\$56.99



Throttle Cable

Throttle cable is designed for fuel injected or carbureted Sprint car applications. Smooth-working cable is 5' in length and features 10/32" threaded ends.
ALL54145 ..\$44.99



Throttle Bell Cranks

Designed for Sprint car apps, each bell crank is fitted with a pressed bearing for smooth throttle operation and has optional locations for connecting push rods of various lengths. Typically 2 are required to complete an app. ALL54150 pivot hole is .275", ALL54152 pivot hole is .250". Option holes on each crank are .188" and spaced 3/8" apart.

Arms Set 75 Deg. Apart, Alum, 35 Grams
ALL54150 ..\$26.79



Arms Set 70 Deg. Apart, 6061 Alum, 40 Grams
ALL54152 ..\$28.99

Body Radius Tool

Solid Oak tool can be used to flare edges of wheel openings when fabricating fenders and quarter panels out of aluminum. Tool has two different radiuses.
ALL23100 ..\$47.99



Access Panel Kits

Aluminum panels mount with rivets or bolts and provide easy access to dry sump pump tanks, fuel cells or other under panel items. Kits includes frame, access door, hinge, flush head quick turn fastener and quick turn fastener spring.

6" x 6"ALL18530.....\$29.99
6" x 14"ALL18532.....\$42.99



Hinge Kits

Use steel hinge kits on hoods and deck lids for quick, one person inspection of engine compartment otr truck area. Universal kits include two complete hinges.

2-1/4" L. x 5/8" H., 1/4" Hole ...ALL18522.....\$6.39
3" L. x 1-1/4" H., 1/4" Hole,
Radiused Edges.....ALL18523.....\$7.39



Body Bolt Kits

Bolts are designed for easy installation and removal, have 1/4"-20 thread, are 3/4" long and have a built-in captured washer. Nuts have built-in serrations which prevent loosening. Body bolts are commonly found on dirt late models to fasten fenders and side skirts but may be used anywhere a bolt with a captured washer is needed. Black phosphate coated.
10-PackALL18560.....\$8.49



Body Brace Kit

Slotted aluminum kit simplifies installation of body panels. 3 door braces, 2 lower quarter, 2 upper quarter, and 2 front fender pieces are included. Use flat stock, spring steel, or slotted strapping to complete assembly (sold separately).
ALL23105 ..\$99.99

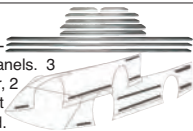

Lead Ballast

Lead Ballast can be used to add weight where it's needed. Available in 25, 30 and 40 pound blocks.
30 lb Lead BallastALL14179\$78.99
25 lb Lead BallastALL14180\$68.99
40 lb Lead BallastALL14182\$102.99



Clamp-On 25 Lb. Ballast

Securely add weight where it's needed. Clamp-on design is formed of two halves which bolt together around 1" to 1-3/4" round tubing allowing easy installation and removal. Bolts are included for use on tubing up to 1-5/8". When clamping to 1-3/4" tubing, longer bolts (not included) are required.
25 Lb. Bolt Together Ballast 4-1/2" Long x 5-1/2" Wides
ALL14181\$76.99



Sprint Wash Plug Sets

Aluminum plugs have O-rings for a water tight seal and will keep dirt out of injectors while cleaning sprint car. 4-piece set includes a nylon storage pouch.
2.4375" Dia.ALL26032.....\$244.99
2.500" DiaALL26033.....\$244.99
2.8125" Dia.ALL26035.....\$244.99
2.900" DiaALL26036.....\$244.99
3.000" DiaALL26038.....\$244.99



Sprint Fuel Pressure Gauge

Fuel pressure indicator gauge allows pre-adjustment of the high speed, secondary and main valve opening pressures using a compressed air source. Gauge can be mounted directly to the wall or tool box. 4-1/2" diameter dial has a 0-160 psi range.
ALL40330\$189.99



Rayburn LM Threaded Plug Kit

3/4"-16 plastic plugs easily thread into rear suspension bungs found on Rayburn Late Models to keep out dirt and debris. Red plugs sold in a package of 10.
ALL50850\$6.99



Torsion Bar Plug Kit

Tapered plugs provide a snug fit but can be easily removed from torsion bars. Red plugs sold in a package of 10.
ALL50852\$6.99

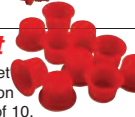

PANELfast Aluminum Washer for 1/4" Body Bolt

1" Alum. Washer for 1/4" Body Bolt - Qty: 50
Silver.....PAN8600.....\$52.64
Black.....PAN8601.....\$59.86

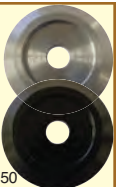

1/4-20" Body Bolt w/Captured Washer - Qty: 50
Silver.....PAN8604.....\$8.94
Black.....PAN8604-BK\$8.56

1/4-20" x 1-1/4" Flanged Body Bolt w/Captured Washer
Qty: 50PAN8605.....\$12.98



Wrap Around Gussets

Gussets fit 1.50" to 1.75" tubing and can be used to join tubing from 70 deg to 110 deg. Gussets provide more support and rigidity than a std flat gusset. Sold in packs of 10.
ALL22199\$16.79



4 Hole Upper A-Arm Mount

Mount is flame cut from 1/2" thick steel, with 6" bolt spacing. Welds to frame and accepts upper A-frame.
ALL60190\$13.79



Fuel Cell Mounting Brackets

Steel bkts are .085" thick & available in 3 different heights. All have 3/8" holes.
2"ALL60060\$3.59
4-3/4"ALL60062\$5.29



Spring Steel

Use to make braces when hanging body and fender pieces. Hardened and tempered coil is 40' long x 1" wide x .062" thick.
ALL23110\$74.99



Steel Hood Pin Kits

Include (2) each: 1/2" dia. chrome steel pins, chrome steel scuff plates, clips, and four nuts. Available with flip-over or hairpin-style clips.
3/16" Dia. Flip-Over Clips...ALL18512.....\$7.99
1/4" Dia. Flip-Over Clips...ALL18513.....\$8.99
5/32" Dia. Hairpin ClipsALL18514.....\$6.99



Alum. Hood Pin Kits

1/2" Pins & 1/4" Clips

Include (2) each: 1/2" dia. alum pins, alum scuff plates, flip over style, 1/4" dia. steel clips, and four nuts. Clip flips over stud, locks into place and over center action keeps pin in place.
Silver (Plain) Kit.....ALL18500.....\$10.99
Red Anodized Kit.....ALL18501.....\$10.99
Blue Anodized Kit.....ALL18502.....\$10.99
Gold Anodized Kit.....ALL18503.....\$10.99
Black Anodized Kit.....ALL18504.....\$10.99



Alum Hood Pin Kits

3/8" Pins & 3/16" Clips

Include (2) alum 3/8" dia. pins, (2) alum scuff plates, (2) flip over style 3/16" dia. steel clips, and locks into place. Over-center action keeps clip in place.
Silver (Plain) Kit.....ALL18480\$10.99
Red Anodized Kit.....ALL18481\$10.99
Blue Anodized Kit.....ALL18482\$10.99
Black Anodized KitALL18484\$10.99
Replacement Pin Silv 2-Pack....ALL18487\$6.99



Lightweight Hood Pin Kits

Kits include 2 gun-drilled aluminum pins, 2 steel clips, 2 LW aluminum plates, and 4 nuts.
3/8" Silver.....ALL18472.....\$12.99
3/8" Black.....ALL18473.....\$12.99
1/2" Silver.....ALL18476.....\$12.99
1/2" Black.....ALL18477.....\$12.99



Hood Pin Mounts

Mounts ease hood pin installation. Choose from threaded boss or tab style.

1/2"-20, Hood Pin Boss (2-Pack)...ALL18520...\$3.99
3/8"-24, Hood Pin Boss (2-Pack)...ALL18521...\$3.69
Mounting Tab (4-Pack)ALL60030...\$5.99



Throttle Sponge

Compact, LW "Throttle Sponge", softens throttle action & prevents bent or damaged linkage. Fits on carb or firewall & is compatible with male or female throttle linkage components. Linkage must be shortened & the proper return springs must be selected in order for the "Throttle Sponge" to react properly. 2 springs will generally provide the best results. The device may be locked out by placing the "E" clip closer to the center of the unit.
ALL26070.....\$29.99





Screw-In Upper Ball Joint

Fits Lefthander chassis style upper A-Frame or where a screw-in type ball joint is required. (Alternate - Moog K772 or AFCO 20034)

Screw-In Upper Ball Joint ...ALL56214\$18.59

Bolt-In Upper Ball Joint

Fits U-B Machine style upper A-Frames where a bolt-in style ball joint is required. (Alternate - Moog K6024, TRW 10185 or AFCO 20031)

Bolt-In Upper Ball JointALL56204\$18.99

Bolt-in type joint fits Impala spindle. Can be used to raise roll center on street stock and modified cars. Fits Impala, Camaro and Chevelle spindles. (Alternate - Moog K6136, TRW 10269 or AFCO 20032-1)

Bolt-In Upper Ball Joint ...ALL56208....\$15.99

Fits popular full-size 1971-94 Impala spindles. Also fits 1971-81 Camaro and 1973-88 Chevelle/Monte Carlo. (Alternate - Moog K5208, TRW 10268 or AFCO 20032)

Upper Ball Joint.....ALL56220\$14.99

Steel Upper Ball Joint Wrench

Wrench is designed to remove and install common upper screw-in upper ball joint that are 1.900" wide

(ALL56214).
ALL11190\$14.99

Ball Joint Spreader Tool

Tool separates ball joint from control arm or spindle. Inside of cylinder is shaped to fit tapered stud of ball joint.

Ball Joint Spreader Tool.....ALL11174.....\$34.99
1" Extensions (Set Of Two).....ALL11175.....\$26.79

Low Friction Upper Ball Joints

Low friction economical OEM ball joints are high performance units designed for smooth suspension travel. Some ball joints are available with longer than stock pin length for correcting roll centers. Ball joints have hardened pins with stock type housings and are not rebuildable. Legal for classes that require non-take apart ball joints. For off-road use only.

Type.....Length.....Taper Per Ft.....Part #Price
ALL56214 and Moog K772

Screw-In...Standard.....1-1/2"ALL56010...\$48.99
Screw-In...1/2" Longer.....1-1/2"ALL56011...\$48.99
Screw-In...1" Longer.....1-1/2"ALL56012...\$48.99

ALL56204 and Moog K6024
Bolt-InStandard.....1-1/2"ALL56014...\$48.99

ALL56208 and Moog K6136
Bolt-In3/8" Longer.....1-1/2"ALL56015...\$48.99

ALL56220 and Moog K5208
Bolt-InStandard.....2"ALL56018...\$48.99
Bolt-In1/2" Longer.....2"ALL56019...\$48.99

Adjustable Upper Ball Joints

Mono-ball joints enable upper control arm angles to be adjusted. Joints include plate, ball, tapered shaft, adjuster bushings and nut. Specify right or left when ordering.

Large GM Ball Joint LHALL56260.....\$54.99
Large GM Ball Joint RHALL56261.....\$54.99
Mid-Size GM Ball Joint LHALL56264.....\$54.99
Mid-Size GM Ball Joint RHALL56265.....\$54.99
Screw-In Upper Ball JointALL56267.....\$71.99

Replacement Parts

Stud for 56260, 56261, & 56267...ALL56262.....\$20.99
Stud for 56264 & 56265.....ALL56266.....\$20.99
Replacement Mono
Ball Bearing 5/8"ALL99098.....\$20.99

Ball Joint Sleeves

Steel sleeves allow custom fabrication of control arms.

Small Screw-In Upper
Fits Ball Joint ALL56214..... ALL56250\$9.99
Large Screw-In Lower
Fits Ball Joint ALL56216..... ALL56251\$9.99
Large Press-In Lower
Fits Ball Joint ALL56206..... ALL56252\$9.99
Medium Press-In Lower
Fits Ball Joint ALL56212..... ALL56253\$9.99

Screw-In Lower Ball Joints

Fits Lefthander chassis style lower A-Frame or where a large screw-in type ball joint is required. (Alternate - Moog K727 or AFCO 20036)

Large Thread Low Ball Joint
ALL56216\$22.99

Universal Ball Joint

Compatible with stock lower control arms modified with UB Machine UBM40-3303 weld-in threaded sleeve. (Alternate - Moog K719)

Threaded Lower Ball Joint
ALL56217.....\$19.99

Lower Ball Joint

Weld-in joint fits most tubular A-Frames including popular 1971-76 Impala A-Frames. Taper fits most tubular and Impala spindles. Base O.D. is 2.190" (Alternate - Moog K6141, TRW 10267 or AFCO 20038)

Weld-In Lower Ball JointALL56206.....\$16.99

Weld-in lower joint fits 1964-72 Chevelle and 1967-69 Camaro, control arms and spindles. (Alternate - Moog K5103, TRW 10197, or AFCO 20033)

Lower Ball Joint.....ALL56210...\$15.99

Weld-in joint fits Impala spindle. Can be used to raise the roll center on street stock or modified cars. Base O.D. is 1.975". (Alternate - Moog K6117, TRW 10264 or AFCO 20038-1)

Weld-In Lower Ball JointALL56212.....\$16.99

Fits popular full-size 1977-89 Impala spindles. Also fits 1971-81 Camaro and 1973-88 Chevelle/Malibu. (Alternate - Moog K6145, TRW 10277 or AFCO 20039)

Lower Ball Joint.....ALL56218.....\$16.49

Ball Joint Adapter Sleeve

Adapter sleeve is ideal for modifying stock style Chevelle lower control arms to accept a screw-in style ball joint. Adapter sleeve has an O.D. of 2.010" to take the place of a press-in style ball joint (ALL56210/K5103) allowing for installation of a screw in style ALL56214 with a (1.5" taper/ft.) pin or ALL56049 with a (2" taper/ ft.) pin ball joint.

ALL56256\$10.99

Low Friction Lower Ball Joints

Low friction economical OEM ball joints are high performance units designed for smooth suspension travel. Some ball joints are available with longer than stock pin length for correcting roll centers. Ball joints have hardened pins with stock type housings and are not rebuildable. Legal for classes that require non-take apart ball joints. For off-road use only.

Type.....Length.....Taper Per Ft.....Part #Price
ALL56126 and Moog K727

Screw-In...Standard.....1-1/2"ALL56030...\$48.99
Screw-In...1/2" Longer.....1-1/2"ALL56031...\$48.99

ALL56216 Housing with ALL56206 Pin
Screw-In...Standard.....2"ALL56034...\$48.99
Screw-In...1/2" Longer.....2"ALL56035...\$48.99

ALL56214 Housing with ALL56206 Pin
Screw-In...Standard.....2"ALL56049...\$48.99
Screw-In...1/2" Longer.....2"ALL56050...\$48.99
Screw-In...1" Longer.....2"ALL56051...\$48.99

ALL56206 and Moog K6141
Weld-In...Standard.....2"ALL56038...\$48.99

ALL56210 and Moog K5103
Weld-In...Standard.....1-1/2"ALL56042...\$48.99

ALL56210 Housing with ALL56206 Pin
Weld-In...Standard.....2"ALL56027...\$48.99
Weld-In...1/2" Longer.....2"ALL56028...\$48.99
Weld-In...1" Longer.....2"ALL56029...\$48.99

ALL56212 and Moog K6117
Weld-In...Standard.....2"ALL56044...\$48.99

ALL56218 and Moog K6145
Weld-In...Standard.....2"ALL56046...\$48.99
Weld-In...1/2" Longer.....2"ALL56047...\$48.99
Weld-In...1" Longer.....2"ALL56048...\$48.99

Adjustable Lower Ball Joints

Replace standard ball joint with an adjustable mono-ball style lower ball joint. Complete with adapter sleeve, ball, adjuster bushings, stud and nut.

Screw-In Chrysler Joint (Common Dirt, 56216 Style)
ALL56270\$71.99

Screw-In GM Impala Stud Joint (Common Asphalt, 56216 Style with 56206 Pin)
ALL56276\$69.99

Press-In Large GM Joint (Common Asphalt, 56206 Style)
ALL56272\$71.99

Press-In Mid-Size GM Joint (ALL56218 Style)
ALL56274\$79.99

Replacement Parts

Stud for 56270ALL56271\$20.99
Stud for 56272 & 56276..... ALL56273\$20.99
Stud for 56274ALL56275\$20.99
Housing for 56270 & 56276..... ALL99092\$34.99
Housing for 56272ALL99093\$34.99
Housing for 56274ALL99094\$34.99
Replacement Mono-BallALL58002\$7.99
Replacement Snap Ring.....ALL99096\$2.69
Replacement Spacer Kit..... ALL99097\$13.49

Adapter Bushing

Convert a 2" taper per foot hole to accept a ball joint with a 1-1/2" taper per foot. For lower ball joints only.

ALL56225\$12.79



4-Bolt Style Ball Joint

QA1's 4-Bolt Style Ultimate Ball Joint is ideal for a variety of racing applications. Exclusive to QA1, this patented, self-lubricating design is 100% owner rebuildable.

Fits Upper Taper of Pinto Spindles
Upper GMQA11210-101\$50.79

73-95 Chevy Blazer, GMC Trucks, Modifieds, Street Stocks
Upper GmQA11210-103\$50.79

71-96 Impala, 70-81 Camaro/Firebird, 73-88 Chevelle/Malibu, 73-88 Monte Carlo, 71-81 GTO, 75-79 Nova/Chevy II and S-10 Trucks
Upper GMQA11210-104\$50.79

Screw-In Style Ball Joint

This patented, self-lubricating design is 100% owner rebuildable and is exclusive to QA1. With multiple stud lengths available, geometry changes can easily be made.

Fits 71-76 Impala, Popular Late Models, Most Wide Type Cars
Lower GMQA11210-102\$50.79

Fits Upper and Lower Tapers in Pinto Spindle Upper MountQA11210-105\$50.79

Fits 60-66 Imperial, Nearly All Strut Cars and Large Taper Late Models - Lower Mopar
NASCAR - Lower
QA11210-106\$50.79

73-78 Charger, 73-74 GTX, 68-73 Road Runner, 79-80 Duster, Most Modifieds, Most Wide Type Cars
Lower MoparQA11210-107\$50.79

NASCAR - Upper Nascar
QA11210-111\$50.79

Press-In Style Ball Joint

A 100% owner rebuildable design, the Ultimate Ball Joint is a QA1 exclusive. This patented, self-lubricating ball joint is offered with multiple stud lengths, providing for easy geometry changes.

Fits Impala Spindle, Impala Type Mods, Street Stocks
Lower GMQA11210-108\$50.79

Fits 70-02 Camaro/Firebird, 73-88 Chevelle/Malibu, 71-96 Impala, 73-88 Monte Carlo, 75-79 Nova/Chevy II, 77-81 GTO, Mini Stocks
Lower GMQA11210-109\$50.79

Fits 67-69 Camaro/Firebird, 64-72 Chevelle/Malibu, 70-72 Monte Carlo, 68-74 Nova/Chevy II, 64-70 GTO, Most Popular Modifieds
Lower GMQA11210-110\$50.79

All Howe, Rayburn, GRT, Warrior, Port City, Popular LM, Most Wide Type Dirt Cars
LowerQA11210-112\$50.79

Adjustable Centerlinks



Links add strength and adjustability. Correct bump steer with specially designed inserts (available separately or in kits). Insert kits include one each of four different offsets. Lower center design adds engine oil pan clearance.

Centerlink Metric GM '78-88ALL56330.....**\$179.99**
 Centerlink Camaro '70-81ALL56331.....**\$179.99**
 Insert Kit 0, 1/8", 1/4", 3/8"ALL56334.....**\$36.99**
 Insert 0" Offset (Centered)ALL56335.....**\$9.99**
 Insert 1/8" OffsetALL56336.....**\$9.99**
 Insert 3/8" OffsetALL56338.....**\$9.99**

Center Links



Brand new center links for many GM applications. Mounting hardware included.

'68-72 Buick Special, Skylark, Grand Sport, '64-72 Chevy Chevelle, El Camino, Monte Carlo, Olds Cutlass, Hurst, 442
 ALL56310.....**\$48.99**
 '73-77 Buick Century, Regal, Chevy Chevelle, El Camino, Monte Carlo, Olds Cutlass, Hurst, 442
 ALL56311.....**\$45.99**
 '78-81 Buick Century, Regal GN, GNX, '78-88 Chevy Malibu, El Camino, Monte Carlo, '82-86 Pontiac Bonneville, '78-87 Grand Prix
 ALL56312.....**\$45.99**
 '77-84 Cadillac Fleetwood, Brougham, Deville, '77-96 Chevy Caprice, Impala, Impala SS, '77-85 Olds Delta 88, '77-81 Pontiac Bonneville, Catalina, '83-86 Parisienne
 ALL56313.....**\$48.99**

Inner Tie Rod End



Common taper fits most centerlinks along with Sweet and other popular steering racks with tapered eyes. Tie rod end has 5/8" RH threads that measure 3-1/2" long. Measures 7" from joint centerline to end of thread.
 ALL56200.....**\$14.49**

Lower A-Frames



Allstar Lower A-Frames fit Port City as well as other racing chassis. Complete with ball joint and rod end.
 Left Lower A-FrameALL56180.....**\$79.99**
 Right Lower A-FrameALL56181.....**\$79.99**
 RH - Lower Control Arm.....ALL56182.....**\$79.99**

Lower Control Arm Kits



Univ kits are 2" longer than std arms and must be cut to length before welding slug into place. Ball joint sold separately.

RH Kit, Use With Press-In Ball Joint (ALL56206)
 ALL56185.....**\$69.99**
 RH Kit, Use With Screw-In Ball Joint
 ALL56187.....**\$78.99**

Panhard Bar/3rd Link Bkts

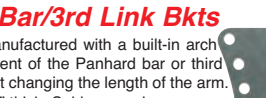

Brackets are manufactured with a built-in arch to allow adjustment of the Panhard bar or third link angle without changing the length of the arm. Brackets are 1/8" thick. Sold as a pair.
 6 Hole Bkt 5/8" HolesALL60163.....**\$9.99**
 6 Hole Bkt 3/4" HolesALL60165.....**\$10.79**
 5 Hole Bkt (Pair)ALL60167.....**\$10.89**

Panhard Bar Bkt



Weld-on bkt is made from 1/4" steel and has six different 3/4" mount holes for Panhard bar. Measures 8-1/2" tall by 2" wide.
 6 Hole Panhard Bracket.....ALL60168.....**\$16.99**



Ball Joint Holders

Holders are ideal for the racers who fabricate their own A-arms. The holders have a 5/8" male RH thread and a 3/8" hole which is commonly used with a clevis. Holders accept Screw-in Ball Joints, which are sold separately

Angled Stud, Angled Tab, Std Spread
 LHALL56290.....**\$21.49**
 RHALL56292.....**\$21.49**

Angled Stud, Angled Tab, Wide Spread
 LHALL56294.....**\$21.49**
 RHALL56295.....**\$21.49**

Universal Straight Stud, Straight Tab, Wide Spread
 ALL56296.....**\$21.49**

5/8" RH Steel Clevis (Commonly Needed)
 ALL56194.....**\$14.29**

Screw-In Ball Joint.....ALL56214.....**\$18.59**



Adjustable Panhard / J-Bar With Rubber Center

It has a rubber center to cushion side loading and improve handling. Bar is 1-1/2" diameter steel tubing. Center-to-center length adjusts from 18-1/2" to 23".
 ALL56157.....**\$109.99**

Seals-it

Rod End Seals

Keep dirt out of your rod ends. Sold in package of 6.

5/16" SealsSEAWS31256PK **\$12.36**
 3/8" SealsSEAWS3750**\$10.95**
 7/16" SealsSEAWS4375**\$10.95**
 1/2" SealsSEAWS5001**\$10.95**
 5mm SealsSEAWS5MM6PK **\$14.22**
 5/8" SealsSEAWS6250**\$12.95**
 3/4" SealsSEAWS7500**\$13.95**



GM Trailing Arm Brackets

Mts GM lower arms to 3" axle tubes. Sold as pair.
 AFC20285.....**\$72.99**



Pull Bar Cover

• Length: 7" • Material: Denier
 • Circumference: 15-3/4"
 OUT30-2608-01.....**\$23.95**

UMP Tubular Lower Control Arms

They are made with 1-1/4" D.O.M. tubing for max strength. Black powder coated with high quality rod ends, arms accept stock replacement ball joints. Conventional springs must be mounted with the closed end seated in the control arm and the open end in the upper spring cup.

RH, '68-72 ChevelleALL56320.....**\$147.99**
 LH, '68-72 ChevelleALL56321.....**\$147.99**
 RH, '68-74 NovaALL56323.....**\$147.99**
 LH, '68-74 NovaALL56324.....**\$147.99**

Ball Joint Socket

Installing ball joints has never been easier. They are machined out of steel, zinc plated and accepts a 1/2" drive ratchet or breaker bar. Now you don't have to use that big old clumsy Crescent wrench.

UpperJOE40050.....**\$41.95**
 LowerJOE40075.....**\$41.95**

Upper Link Brackets

Weld-on brackets have curved 3/4" slots to maintain pinion angle as the 3rd link is raised or lowered. Both brackets are notched for 1-3/4" round tubing and are 3/16" thick.

5-1/2" Upper Link Bracket.....ALL60065.....**\$28.99**
 8-5/8" Upper Link Bracket.....ALL60066.....**\$25.99**

Quick Change Upper Link Brackets

Bracket bolts to top of quick change and accepts upper link. ALL60154 is 1/4" thick, gold anodized alum and has a 3/4" x 4-1/2" slot for quick adjustment. ALL60150 is steel with three 3/4" holes, 3" to the rear for forward traction. ALL60156 is 1/4" thick steel with multiple holes, popular on modifieds. Sold in pairs.

Steel w/3 HolesALL60150.....**\$36.99**
 Aluminum w/4-1/2" SlotALL60154.....**\$49.99**
 Steel w/Multiple HolesALL60156.....**\$54.99**

Upper Link Bracket Kit

Bracket bolts to top of most quick change rearends to provide mounting locations for upper link and 90/10 shocks. Made 1/4" alum, each bracket kit includes Grade 8 mounting hardware and aluminum sleeve spacers that can be cut to position upper link and shocks.
 ALL60155.....**\$79.99**

9" Ford Upper Link Brackets

They provide a mounting point for upper link. Weld-on bkts fit std steel Ford housings. Bkts have 1" dia holes unless noted.

Weld-On Upper Link Bkt (2 Required, Sold Individually).....ALL60160.....**\$13.99**
 Weld-On Upper Link Bkt (1 Required)
 ALL60161.....**\$49.99**

Weld-On Upper Link Bkts, 3/4" Dia. Holes (2-Pack).....ALL60166.....**\$23.99**

Steel Control Arm Bushings

They replace stock rubber bushings and eliminate deflection, a common problem with original equipment bushings.

Lower Control Arm Bushing Apps Chevelle, Mont Carlo, GM Int Hole

Description.....	Length.....	Size
1.345" '64-66 (Front) **2.100".....	.500"ALL56230..... \$16.99
1.345" '67-74 (Front).....	2.100".....	.500".....ALL56230..... \$16.99
1.645" '64-66 (Front) ?.....	2.100".....	.500".....ALL56232..... \$16.99
1.645" '75-77 (Front).....	2.100".....	.500".....ALL56232..... \$16.99
1.645" '64-72 (Rear).....	2.100".....	.500".....ALL56232..... \$16.99
1.645" '78-88 (Rear).....	2.100".....	.500".....ALL56232..... \$16.99
1.645".....	2.100".....	.562".....ALL56233..... \$16.99
1.900" '73-77 (Rear).....	2.100".....	.500".....ALL56234..... \$16.99
1.900".....	2.100".....	.562".....ALL56235..... \$16.99
1.440" '78-88 (Front).....	2.750".....	.500".....ALL56236..... \$16.99

Camaro, Firebird

1.345" '67-74 (Front).....2.100"......500".....ALL56230.....**\$16.99**
 1.645" '75-Up (Front).....2.100"......500".....ALL56232.....**\$16.99**
 1.645" '67-72 (Rear).....2.100"......500".....ALL56232.....**\$16.99**
 1.900" '73-88 (Rear).....2.100"......500".....ALL56234.....**\$16.99**

Upper Control Arm Bushing Apps Chevelle, Mont Carlo, GM Int

1.275" '67-72 (All)1.250"......675".....ALL56238.....**\$11.69**
 1.530" '78-88 (All)1.500"......695".....ALL56240.....**\$11.69**
 1.394" '73-77 (Front).....1.500"......690".....ALL56242.....**\$11.69**
 1.311" '73-77 (Rear).....1.425"......690".....ALL56244.....**\$11.69**

Camaro, Firebird

1.275" '67-69 (All)1.250"......675".....ALL56238.....**\$11.69**
 1.394" '74-79 (Front).....1.500"......690".....ALL56242.....**\$11.69**
 1.311" '74-79 (Rear).....1.425"......690".....ALL56244.....**\$11.69**
 * 1st Design ** 2nd Design

PANELfast



3/16" Oval Head

Grip	Steel
.250 grip	PAN3250...\$1.49
.300 grip	1.49.....\$1.49
.400 grip	PAN3400...\$1.52



1/4" Oval Head

Grip	Steel	Aluminum
.250 grip	PAN4250....\$1.49	
.400 grip	PAN4400....\$1.52	
.550 grip	PANA4550..\$1.69	Aluminum



5/16" Oval Head

Grip	Steel	Aluminum	Aluminum Black
.350 grip	PAN5350...\$1.49		
.400 grip	PAN5400...\$1.32	PANA5400...\$1.63	
.450 grip	PAN5450...\$1.34	PANA5450...\$1.63	
.500 grip	PAN5500...\$1.46	PANA5500...\$1.63	PANABK5500 \$1.69
.550 grip	PAN5550...\$1.57	PANA5550...\$1.69	
.600 grip	PAN5600...\$1.57	PANA5600...\$1.73	
.650 grip	PAN5650...\$1.61	PANA5650...\$1.73	



5/16" Big Oval Steel

.400 grip	PANBIG-5400...\$1.87
.450 grip	PANBIG-5450...\$1.93
.500 grip	PANBIG-5500...\$1.96



Grip	Steel Black NEW
.450 grip	PANBK6450...\$2.09
.500 grip	PANBK6500...\$2.09
.600 grip	PANBK6600...\$2.15

7/16" Oval Head

Grip	Steel	Aluminum	Aluminum Black
.400 grip	PAN6400...\$1.35	PANA6400...\$1.47	
.450 grip	PAN6450...\$1.35	PANA6450...\$1.51	PANABK6450...\$1.79
.475 grip	PAN6475...\$1.35		
.500 grip	PAN6500...\$1.35	PANA6500...\$1.54	PANABK6500...\$1.83
.550 grip	PAN6550...\$1.38	PANA6550...\$1.54	PANABK6550...\$2.11
.600 grip	PAN6600...\$1.38	PANA6600...\$1.63	PANABK6600...\$2.13
.650 grip	PAN6650...\$1.50	PANA6650...\$1.79	
.750 grip	PAN6750...\$1.63	PANA6750...\$1.83	
1.000 grip	PAN6100...\$1.86	PANA6100...\$1.96	



7/16" Big Oval

Grip	Steel	Aluminum
.450 grip	PANBIG-6450...\$1.93	PANBIG-A6450...\$1.98
.500 grip	PANBIG-6500...\$1.93	PANBIG-A6500...\$1.98
.550 grip		PANBIG-A6550...\$2.10
.600 grip	PANBIG-6600...\$1.98	PANBIG-A6600...\$2.12
.650 grip	PANBIG-6650...\$2.01	
.750 grip	PANBIG-6700...\$2.05	

Black

.500 grip	PANBIG-BK6500...\$2.51	PANBIG-ABK6550...\$2.65
.550 grip		
.600 grip	PANBIG-BK6600...\$2.54	

5/16" Flush Head

Grip	Steel	Aluminum
.400 grip	PANF5400...\$1.49	PANFA5400...\$1.56
.450 grip	PANF5450...\$1.49	PANFA5450...\$1.60
.500 grip	PANF5500...\$1.52	PANFA5500...\$1.63
.550 grip	PANF5550...\$1.51	PANFA5550...\$1.66
.600 grip	PANF5600...\$1.54	PANFA5600...\$1.66
.650 grip	PANF5650...\$1.54	PANFA5650...\$1.69



7/16" Flush Head

Grip	Steel	Aluminum
.400 grip	PANF6400...\$1.40	PANFA6400...\$1.63
.450 grip	PANF6450...\$1.43	PANFA6450...\$1.66
.500 grip	PANF6500...\$1.43	PANFA6500...\$1.66
.550 grip	PANF6550...\$1.46	PANFA6550...\$1.66
.600 grip	PANF6600...\$1.49	PANFA6600...\$1.73
.650 grip	PANF6650...\$1.61	PANFA6650...\$1.76



7/16" Allen Flush

Grip	Steel	Aluminum
.400 grip	PANBF6400...\$1.50	PANBFA6400...\$1.63
.450 grip	PANBF6450...\$1.50	PANBFA6450...\$1.66
.500 grip	PANBF6500...\$1.50	PANBFA6500...\$1.66
.550 grip	PANBF6550...\$1.53	PANBFA6550...\$1.71
.600 grip	PANBF6600...\$1.55	PANBFA6600...\$1.76
.650 grip	PANBF6650...\$1.57	PANBFA6650...\$1.76



5/16" Allen Oval

Grip	Steel	Aluminum
.400 grip	PANB5400...\$1.40	.550 grip PANB5550...\$1.57
.450 grip	PANB5450...\$1.54	.600 grip PANB5600...\$1.57
.500 grip	PANB5500...\$1.54	.650 grip PANB5650...\$1.61
		.750 grip PANB5750...\$1.63
		1.00 grip PANB5100...\$1.72



7/16" Allen Oval

Grip	Steel	Aluminum
.400 grip	PANB6400...\$1.54	PANBA6450...\$1.69
.450 grip	PANB6450...\$1.54	PANBA6500...\$1.73
.500 grip	PANB6500...\$1.57	PANBA6550...\$1.76
.550 grip	PANB6550...\$1.57	PANBA6600...\$1.76
.600 grip	PANB6600...\$1.63	
.650 grip	PANB6650...\$1.63	
.750 grip	PANB6750...\$1.66	
1.00 grip	PANB6100...\$1.75	
.500 grip	Aluminum Black: PANBANK6500...\$2.08	
.500 grip	Aluminum Red: PANBARD6500...\$2.08	



3000 Series - 3/16" Oval Head Undercut

Grip	Steel
.300 grip (.050 undercut)	PANU3300...\$1.46

1/4" Nylon Washers

.31 Thickness PAN 8414



FASTENERS SHOWN IN ACTUAL SIZE



4000 Series 1/4" Oval Head Undercut

Grip	Steel	Aluminum
.400 grip (.050 undercut)	PANU4400...\$1.51	PANUA4400...\$1.61
.500 grip (.050 undercut)	PANU4500...\$1.57	PANUA4500...\$1.66
.550 grip (.275 undercut)		PANUA4550-275...\$1.82

5/16" Nylon Washers

.31 Thickness PAN8415 \$0.23



5000 Series 5/16" Oval Head Undercut

Grip	Steel	Aluminum
.300 grip	PANU5300...\$1.49	
.350 grip	PANU5350...\$1.49	
.400 grip	PANU5400...\$1.52	PANUA5400...\$1.63
.450 grip	PANU5450...\$1.54	PANUA5450...\$1.63
.500 grip	PANU5500...\$1.54	PANUA5500...\$1.66
.550 grip	PANU5550...\$1.57	PANUA5550...\$1.69
.600 grip	PANU5600...\$1.57	PANUA5600...\$1.73
.650 grip	PANU5650...\$1.61	PANUA5650...\$1.73
.750 grip	PANU5750...\$1.63	PANUA5750...\$1.79
.900 grip	PANU5900...\$1.68	PANUA5900...\$1.86



3/8" Nylon Washers

.31 Thickness PAN8416 \$0.14



5/5000 Series 3/8" Oval Head Undercut

Grip	Steel	Aluminum
.400 grip .150"	PANU5/5400...\$1.54	PANUA5/5400...\$1.63
.500 grip .150"	PANU5/5500...\$1.54	PANUA5/5500...\$1.66
.500 grip .190"	PANU5/5500-190...\$1.54	
.500 grip .238"	PANU5/5500-238...\$1.54	
.600 grip .150"	PANU5/5600...\$1.54	PANUA5/5600...\$1.69
.700 grip .350"	PANU5/5700-350...\$1.57	
.900 grip .150"	PANU5/5900...\$1.61	PANUA5/5900...\$1.79



7/16" Nylon Washers

.31 Thickness PAN 8417 \$0.21



6000 Series 7/16" Oval Head Undercut

Grip	Steel	Aluminum
.400 grip	PANU6400...\$1.54	PANUA6400...\$1.66
.450 grip	PANU6450...\$1.54	PANUA6450...\$1.69
.500 grip	PANU6500...\$1.54	PANUA6500...\$1.73
.550 grip	PANU6550...\$1.54	PANUA6550...\$1.73
.600 grip	PANU6600...\$1.54	PANUA6600...\$1.76
.650 grip	PANU6650...\$1.63	PANUA6650...\$1.79
.750 grip	PANU6750...\$1.66	PANUA6750...\$1.83
.900 grip	PANU6900...\$1.72	PANUA6900...\$1.89



5/16" Nylon Washers

.31 Thickness PAN8415 \$0.23



5/16" Allen Head Undercut

Grip	Steel
.450 grip	PANBU5450...\$1.54
.500 grip	PANBU5500...\$1.54
.600 grip	PANBU5600...\$1.57
.650 grip	PANBU5650...\$1.61



7/16" Nylon Washers

.31 Thickness PAN8417 \$0.23



7/16" Big Head Oval Alum Undercut

Grip	Aluminum
.450 grip	PANBIG-UA6450.....\$1.99

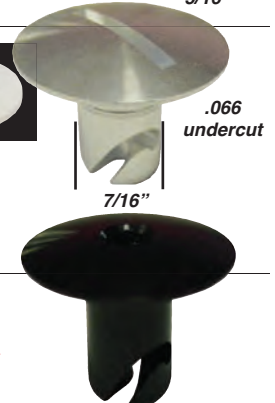

7/16" Allen Big Oval Black

.500 grip	PANBIG-BABK6500...\$2.60
-----------	--------------------------

5/16" Winged Oval

Grip	Steel
.400 grip	PANW5400..\$2.05
.450 grip	PANW5450..\$2.08
.500 grip	PANW5500..\$2.08
.550 grip	PANW5550..\$2.11
.600 grip	PANW5600..\$2.11
.650 grip	PANW5650..\$2.13



7/16" Winged Oval

Grip	Steel
.400 grip	PANW6400..\$2.20
.450 grip	PANW6450..\$2.20
.500 grip	PANW6500..\$2.08
.550 grip	PANW6550..\$2.22
.600 grip	PANW6600..\$2.26
.650 grip	PANW6650..\$2.28



7/16" Winged Flush

Grip	Steel
.450 grip	PANBKW6450..\$2.75 - Black
.500 grip	PANWF6500..\$2.20
.550 grip	PANWF6550..\$2.20



1/4" Nylon Washers
.31 Thickness PAN8414..\$0.23

D-Ring Undercut 1/4" Stud

Grip	Aluminum	Black
.400 grip	PANDRAU4400..\$3.85	PANDRAU4400BK..\$4.40
.500 grip	PANDRAU4500..\$3.85	PANDRAU4500BK..\$4.40



1" Steel Panel Spring

Grip	Gold	Stainless Steel
.200 total grip	PANS5200..\$0.60	PANSSS5200..\$0.60
.225 total grip	PANS5225..\$0.60	PANSSS5225..\$0.60
.250 total grip	PANS5250..\$0.60	PANSSS5250..\$0.60
.275 total grip	PANS5275..\$0.60	PANSSS5275..\$0.60
.300 total grip	PANS5300..\$0.60	PANSSS5300..\$0.60
.325 total grip	PANS5325..\$0.60	PANSSS5325..\$0.60
.350 total grip	PANS5350..\$0.60	PANSSS5350..\$0.60
.375 total grip	PANS5375..\$0.60	PANSSS5375..\$0.60



1 3/8" Steel Panel Spring

Grip	Gold	Stainless Steel
.225 total grip	PANS6250..\$0.60	PANSSS6225..\$0.60
.250 total grip	PANS6275..\$0.60	PANSSS6275..\$0.55
.275 total grip	PANS6300..\$0.60	PANSSS6300..\$0.60
.300 total grip	PANS6325..\$0.60	PANSSS6325..\$0.60
.325 total grip	PANS6350..\$0.60	PANSSS6350..\$0.60
.350 total grip	PANS6375..\$0.60	PANSSS6375..\$0.60
.375 total grip	PANS6375SV..\$0.60 - Silver NEW	
.400 total grip	PANS6400..\$0.60	PANSSS6400..\$0.60
.425 total grip	PANS6425..\$0.60	PANSSS6425..\$0.60
.425 total grip	PANS6425SV..\$0.60 - Silver NEW	



5/8" Stainless Steel Panel Spring

PANSSS3175..\$0.60	5/8" spring .175 total grip
PANSSS3225..\$0.60	5/8" spring .225 total grip



Use with 3/32" Rivets

3/4" Stainless Steel Panel Spring

PANSSS4200..\$0.60	3/4" spring .200 total grip
PANSSS4250..\$0.60	3/4" spring .250 total grip



Use with 3/32" Rivets

Panel Spring Adjuster

It pulls in both directions. We have always been told

But for years there was never the right tool to adjust your Panel button springs. Push on them with a screwdriver and it would kink and weaken the spring, grip with a pair of pliers and again you would crimp and weaken the spring. Worse you would break the spring and have to drill it out and put in another. Panelfast's Panel Spring Adjuster is the right tool, the only tool for the job. It pulls the spring evenly like a panel button so you don't get kinks, or worse, breaks. The panel spring adjuster is quick and easy to use, lightweight, and durable. This is a must have tool for any racing tool box.

PAN7602.....\$52.80

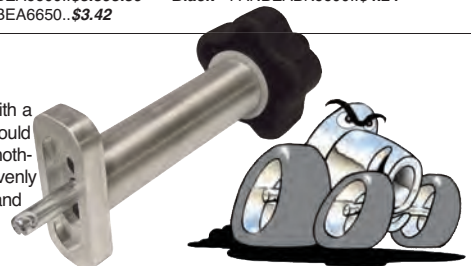

5/16" Winged Self-Eject

Grip	Steel
.400 grip	PANEW5400..\$3.91
.450 grip	PANEW5450..\$3.91
.500 grip	PANEW5500..\$3.91
.550 grip	PANEW5550..\$3.91
.600 grip	PANEW5600..\$3.96
.650 grip	PANEW5650..\$3.98

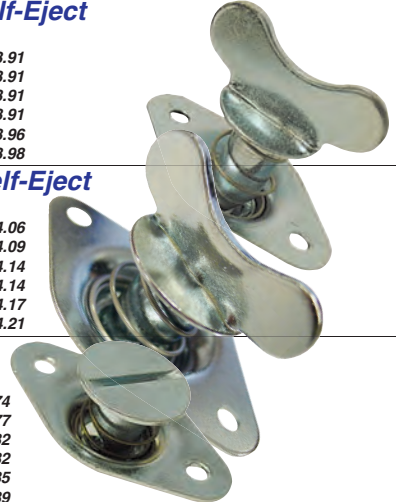

7/16" Winged Self-Eject

Grip	Steel
.400 grip	PANEW6400..\$4.06
.450 grip	PANEW6450..\$4.09
.500 grip	PANEW6500..\$4.14
.550 grip	PANEW6550..\$4.14
.600 grip	PANEW6600..\$4.17
.650 grip	PANEW6650..\$4.21



5/16" Self-Eject

Grip	Steel
.400 grip	PANE5400..\$2.74
.450 grip	PANE5450..\$2.77
.500 grip	PANE5500..\$2.82
.550 grip	PANE5550..\$2.82
.600 grip	PANE5600..\$2.85
.650 grip	PANE5650..\$2.89
.700 grip	PANE5700..\$3.36
.750 grip	PANE5750..\$3.36
.800 grip	PANE5800..\$3.39
.850 grip	PANE5850..\$3.39
1.00 grip	PANE51100..\$3.87
Grip	Aluminum
.500 grip	PANEA5500..\$3.30
.550 grip	PANEA5550..\$3.30

Grip	Aluminum Black
.450 grip	PANEABK5450..\$3.95
.500 grip	PANEABK5500..\$3.96
.550 grip	PANEABK5550..\$4.13
.600 grip	PANEABK5600..\$4.13
.650 grip	PANEABK5650..\$4.13
.700 grip	PANEABK5700..\$4.13
1.100 grip	PANEABK51100..\$4.40

7/16" Self-Eject

Grip	Steel
.400 grip	PANE6400..\$3.28
.450 grip	PANE6450..\$3.28
.500 grip	PANE6500..\$2.85
.550 grip	PANE6550..\$2.89
.600 grip	PANE6600..\$2.93
.650 grip	PANE6650..\$3.16
.700 grip	PANE6700..\$3.39
.750 grip	PANE6750..\$3.43

Grip	Gold	Black
.500 grip	PANE6500G..\$2.99	PANE6500BK..\$4.36
.550 grip		PANE6550BK..\$4.36

1" Steel Panel Spring

Grip	Aluminum	Aluminum Black
.400 grip	PANEA6400..\$3.30	
.450 grip	PANEA6450..\$3.30	
.500 grip	PANEA6500..\$3.30	PANEABK6500..\$4.13
.550 grip	PANEA6550..\$3.31	PANEABK6550..\$4.13
.600 grip	PANEA6600..\$3.31	PANEABK6600..\$4.13
.650 grip	PANEA6650..\$3.31	PANEABK6650..\$4.29
.700 grip	PANEA6700..\$3.01	PANEABK6700..\$4.29



5/16" Allen Self-Eject

Grip	Steel
.500 grip	PANBE5500..\$3.23
.550 grip	PANBE5550..\$3.23



5/16" Allen Self-Eject - Black

Grip	Aluminum
.500 grip	PANBEABK5500..\$4.10
.550 grip	PANBEABK5550..\$4.13
.600 grip	PANBEABK5600..\$4.174.17

7/16" Allen Self-Eject

Grip	Steel
.500 grip	PANBE6500..\$3.31
.550 grip	PANBE6550..\$3.36
.600 grip	PANBE6600..\$3.36

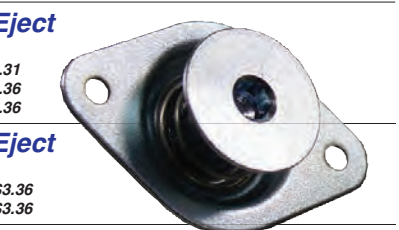

7/16" Allen Self-Eject

Grip	Gold
.500 grip	PANBE6500G..\$3.36
.550 grip	PANBE6550G..\$3.36

7/16" Allen Self-Eject

Grip	Aluminum
.400 grip	PANBEA6400..\$3.30
.450 grip	PANBEA6450..\$3.30
.500 grip	PANBEA6500..\$3.30
.550 grip	PANBEA6550..\$3.34
.600 grip	PANBEA6600..\$3.393.39
.650 grip	PANBEA6650..\$3.42

Black - PANBEABK6500..\$4.07
Black - PANBEABK6550..\$4.07
Black - PANBEABK6600..\$4.24

Weld Plates

1/4" Weld Plate 3/4" Spring

Plates are .090 material.

**FASTENERS
SHOWN IN
ACTUAL SIZE**

Steel Plates are .060 thick. Unless Noted.



PAN8041..\$0.63
PAN8041A..\$0.81



PAN8042..\$0.63
PAN8042A..\$0.81



PAN8040..\$0.63

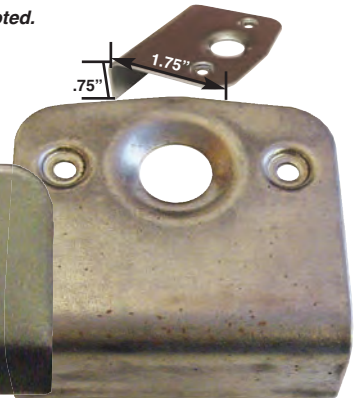

PAN8350-90..\$1.26

5/16" Self Eject 1" Spring



PAN8130
\$0.63



PAN8131
\$0.63



PAN8132 \$0.63
PAN8132A..\$0.81



PAN8350..\$0.68



PAN8130-E5 \$0.98



PAN8100-E5
\$0.98



PAN8131-E5 \$0.98

3/16" Weld Plate 5/8" Spring



PAN8030..\$0.63

7/16" Weld Plate 1-3/8" Spring



PAN8200A090..\$0.81 (.090 material)
PAN8200A120..\$0.95 (.120 material)



PAN8220A090 \$0.81 (.090 material) Alum
PAN8220.090 \$ (.090 material) Steel
PAN8220.75 \$ (.075 material) Steel



PAN8121
\$0.72

For 5/16" Self Eject 1" Spring

**7/16" Self-Eject Weld Plates
For 1-3/8" Spring**

Plates are .060 material.



PAN8215..\$0.63



PAN8224..\$0.63

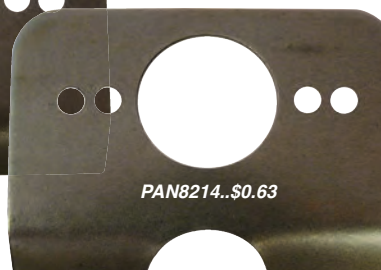

PAN8214..\$0.63

For 1" or 1-3/8" Spring



PAN8122
\$0.96

For 5/16" Self Eject 1" Spring

Weld Plates for 5/16" Fasteners for 1" Springs

Steel Plates are .060 thick. Unless Noted.



Flat Weld Plates for 7/16" Fasteners 1-3/8" Springs

Steel Plates are .060 thick. Unless Noted. PAN8310...\$0.63



Dimpled Weld Plates for 7/16" Fasteners 1-3/8" Springs

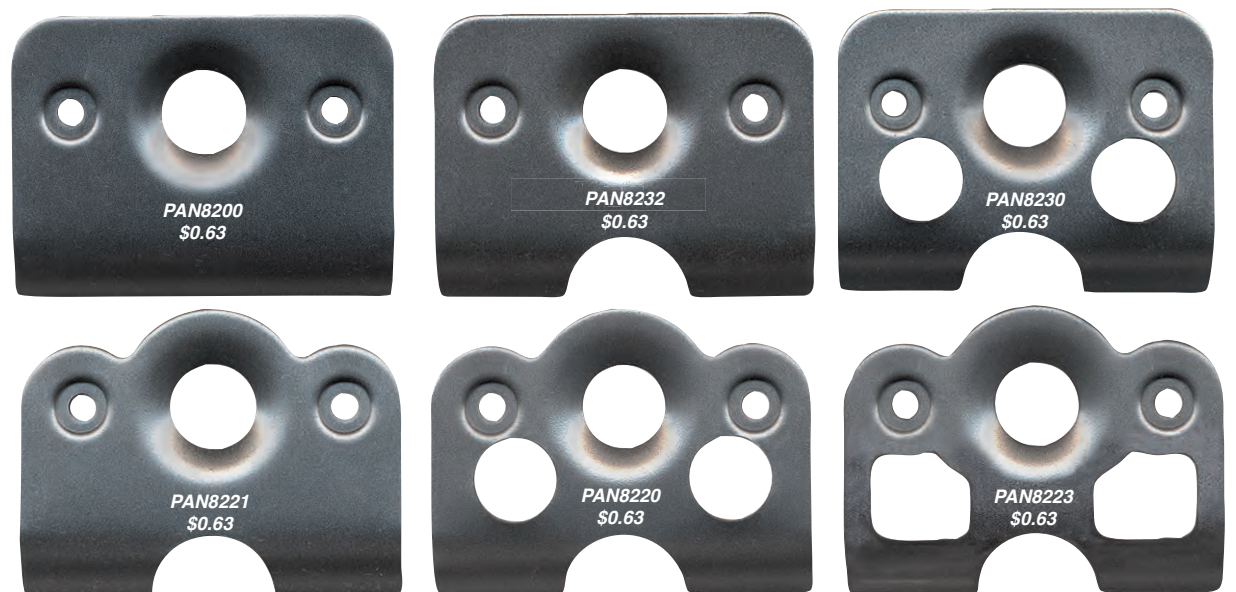



Body Studs w/Plunge Slot

1/2" Thread Height

	Steel	Aluminum	Aluminum (Black)
1" Head: 1/4-20-1/2" Stud	PAN9S160408C ...\$1.97	PAN9A160408C ...\$2.02	PAN9ABK160408C ...\$2.63
1-1/4" Head: 1/4-20-1/2" Stud		PAN9A200408C ...\$2.51	

3/4" Thread Height

	Steel	Aluminum	Aluminum (Black)
1" Head: 1/4-20-3/4" Stud	PAN9S160412C ...\$2.15	PAN9A160412C ...\$2.27	PAN9ABK160412C ...\$2.85
1-1/4" Head: 1/4-20-3/4" Stud		PAN9A200412C ...\$2.85	PAN9ABK200412C ...\$3.42

1" Thread Height

	Steel	Aluminum	Aluminum (Black)
1" Head: 1/4-20-1" Stud	PAN9S160416C ...\$2.30	PAN9A160416C ...\$2.49	PAN9ABK160416C ...\$3.06
1-1/4" Head: 1/4-20-1" Stud		PAN9A200416C ...\$3.18	PAN9ABK200416C ...\$3.78

1-1/4" Thread Height

	Steel	Aluminum	Aluminum (Black)
1" Head: 1/4-20-1-1/4" Stud	PAN9S160420C ...\$2.49	PAN9A160420C ...\$2.70	PAN9ABK160420C ...\$3.30
1-1/4" Head: 1/4-20-1-1/4" Stud	PAN9S200420C ...\$3.11	PAN9A200420C ...\$3.53	PAN9ABK200420C ...\$4.11



Rivet Back Up Plate

3/16" Rivet Back Up Aluminum
.080 x 5/8 x 1.5" Quantity 50
BSC90010.....\$10.50

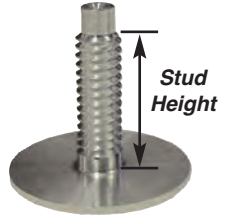

Plunge Slot Buttons

A.) Plunge Slot Steel Oval Head

7/16" Steel Oval Head .400"	PANP6400	\$1.54
7/16" Steel Oval Head .450"	PANP6450	\$1.54
7/16" Steel Oval Head .500"	PANP6500	\$1.57
7/16" Steel Oval Head .550"	PANP6550	\$1.61
7/16" Steel Oval Head .600"	PANP6600	\$1.61
7/16" Steel Oval Head .600"	PANP6650	\$1.63

B.) Plunge Slot Aluminum Oval Head

7/16" Alum Oval Head .500"	PANAP6500	\$1.73
7/16" Alum Oval Head .500" Black	PANAPBK6500	\$2.08

C.) Plunge Slot Aluminum Big Oval Head

7/16" Alum Big Oval Head .500"	PANBIG-AP6500	\$2.05
7/16" Alum Big Oval Head .500" Black	PANBIG-APBK6500	\$2.63

D.) Plunge Slot Undercut

3/8" Undercut .150" Alum Oval .500"	PANUA5/5500P	\$1.66
3/8" Undercut .150" Alum Oval .500" Black	PANUA5/5500PBK	\$2.28
7/16" Undercut Alum Oval .600"	PANPUA6600	\$1.56

E.) Plunge Slot Taper Undercut

7/16" Undercut Taper Alum Oval .550" Grip	PANPUA6550TAPER	\$1.76
---	-----------------	--------

F.) Plunge Flush Slot Aluminum Taper Undercut

7/16" Undercut Flush Taper Alum Oval .500"	PANPFUA6500DSR	\$1.66
--	----------------	--------



Plunge Buttons have a deeper slot in the button.

Panel Spring Adjuster

It pulls in both directions. We have always been told "The right tool, for the right job." But for years there was never the right tool to adjust your Panel springs. Push on them with a screwdriver and it would kink and weaken the spring. Worse you would break the spring and have to drill it out and put in another. It pulls the spring evenly like a panel button so you don't get kinks, or worse, breaks. The panel spring adjuster is quick and easy to use, lightweight, and durable. This is a must have tool for any racing tool box.

Panel Spring Adjuster.....	PAN7602	\$52.80
Replacement Shaft.....	PAN7603	\$22.00

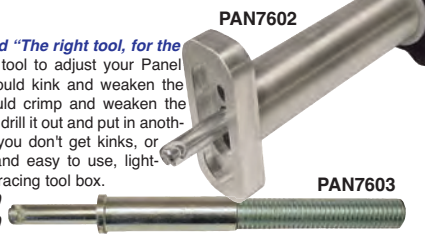

PANELfast Dual Purpose

7/16" Slotted and Hex Tool

Made specifically to be used with Behrent's own Panelfast line. It has hex on one side and 7/16" slotted on the other. It is small enough to fit in your back pocket.

PAN7606.....\$12.95

Quick Fastener Wrench w/Easy Grip Handle

Removing and installing 1/4-turn fasteners just got quicker. Features an easy grip handle and redesigned steel shank plated with black zinc for durability.

Slotted WrenchMOR71606..\$19.54
3/16" Hex Drive Wrench ..MOR71607..\$17.29

Quick Fastener Wrench w/Easy Grip Handle

Removing and installing 1/4-turn fasteners just got quicker. Features an easy grip handle and redesigned steel shank plated with black zinc for durability.

WrenchBSC90008\$12.00

Fastener Wrench

Manufactured of zinc plated spring steel with three different sized radii to match the slots in various 1/4-turn fasteners. Includes non-slip, plastic hand grip.

MOR71600....\$6.11

Fastener Sinking Tool

Ideal for sinking flush-mount quick fasteners. The 2 piece steel tool dimples a single metal panel using one end and a double panel using the other. Zinc plated.

MOR71605....\$38.85

Step Drill Set

Drill multiple size holes with one bit. Drill sheet metal and alum w/o deforming or distorting. Bits start on contact, deburr and chamfer while drilling and do not require a center punch. Titanium nitride coated high speed steel. 1/4" hex shank.

- 6 step bit drills: 3/16", 1/4", 5/16", 3/8", 7/16", 1/2".
- 9 step bit drills: 1/4", 5/16", 3/8", 7/16", 1/2", 9/16", 5/8", 11/16", 3/4".
- 13 step bit drills: 1/8", 5/32", 3/16", 7/32", 1/4", 9/32", 5/16", 11/32", 3/8", 13/32", 7/16", 15/32", 1/2".

Step Drill Set.....ALL11040.....\$17.99

Deburring Tool

A fast and easy way to remove burrs from the edges of machined or cut metals. Comes with 2 Blades.

BSC90009\$8.00

Drill Bits

Ideal for sinking flush-mount quick fasteners. The 2 piece steel tool dimples a single metal panel using one end and a double panel using the other. Zinc plated.

1/8"-1/2" Step Drill 1/4" Shank 13 Step BSC80110...\$12.50
3/16"-7/8" Step Drill 3/8" Shank 12 Step BSC80112....\$18.56

Deburring Tool

A fast & easy way to remove burrs from the edges of machined or cut metals. Five piece kit includes handle, telescopic blade holder and three unique blades. Handle has built-in storage for blades. Blade holder adjusts from 1" to 5".

ALL11036\$17.89



POP PS-15 Rivet Pliers



Includes nose pieces for 3/32", 1/8", 5/32", & 3/16" rivets. Wrench stores inside handle for changes.

BSC90002...\$28.00



Colors Mill

Rivets (Box of 250)

3/16" Dia. x 5/8" Grip x 5/8" Head Alum/Steel ...	Colors: Black, Mill, & White	BSC90029(color)	\$27.24	\$21.61
3/16" Dia. x 3/8" Grip x 3/8" Head - Exploding ...	Colors: Black, Mill, Red, White, Chev Blue, Flat Black, Orange, Pepsi-Blue, & Yellow	BSC90030(color)	\$27.78	\$24.74
3/16" Dia. x 3/8" Grip x 5/8" Head - Exploding ...	Colors: Black, Mill, Red, White, Chev Blue, Flat Black, Orange, Pepsi-Blue, & Yellow	BSC90031(color)	\$32.95	\$30.10
3/16" Dia. x 3/8" Grip x 1/2" Head - Exploding ...	Colors: Black, Mill, & White	BSC90032(color)	\$33.54	\$31.88
3/16" Dia. x 3/8" Grip x 3/8" Head	Colors: Black, Mill, Red, White, Chev Blue, Flat Black, Orange, Pepsi-Blue, & Yellow	BSC90033(color)	\$13.73	\$12.45
3/16" Dia. x 3/8" Grip x 5/8" Head - Multi Grip ...	Colors: Black, Mill, Red, White, Chev Blue, Flat Black, Orange, Pepsi-Blue, & Yellow	BSC90034(color)	\$19.16	\$16.46
1/8" Dia. x 3/8" Grip x 1/4" Head Alum/Steel ...	Colors: Black, Mill, & White	BSC90035(color)	\$8.70	\$7.98
1/8" Dia. x 3/8" Grip x 3/8" Head Alum/Steel ...	Colors: Black, Mill, Red, White, & Chev Blue	BSC90036(color)	\$11.51	\$9.48
3/16" Dia. x 1/2" Grip x 3/8" Head Alum/Steel ...	Colors: Black, Mill, Red, & White	BSC90037(color)	\$16.57	\$15.27
3/16" Dia. x 3/4" Grip x 3/8" Head Alum/Steel ...	Colors: Black, Mill, & White	BSC90038(color)	\$25.16	\$19.95
3/16" Dia. x 1/2" Grip x 5/8" Head Alum/Steel ...	Colors: Black, Mill, Red, & White	BSC90039(color)	\$24.40	\$22.64
3/4" Dia. x 5/8" Grip x 3/16" Head	Colors: Black, Mill, & White	BSC90040(color)	\$25.15	\$23.76

RT-66 Pneumatic Rivet Tool



Big Power in a little package * Rivet Setting Capacity: Steel 3/32", 1/8", 5/32", 3/16" Aluminum 3/32", 1/8", 5/32" & 3/16" - Stainless Steel (3/32", 1/8", 5/32") * Nosepieces Included (3/32", 1/8", 5/32" & 3/16") * Traction Power: 1300 lbs * Air Inlet: 1/4" * Length: 7.7" * Weight: 2.8 lbs BSC90005...\$78.95

Cordless Rivet Tool



14.4 Volt DC, 0.82" pulling stroke, 2,023 lb. pulling force, pulling capacity up to 3/16" alum/steel blind rivets. Tool comes with 4 nosepieces, 2 - 14.4 volt/1.5 Ah Li-Ion battery packs, 120 Volt Battery charger, Spanner wrench (3 in 1), tool weight with battery 2.78 lbs., packed in black blow molded carrying case. BSC90004...\$349.50

Rolled Plastic

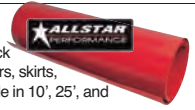

Quality 24" wide by .070" thick plastic can be used for spoilers, skirts, body patchwork, etc. Available in 10', 25', and 50' rolls

10 FT	25 FT	50 FT
Black	ALL22400	ALL22401
	\$91.99	\$91.99
White	ALL22405	ALL22406
	\$103.99	\$103.99

Air Rivet Gun



Heavy duty Air Rivet Gun can be used with steel or alum rivets from 3/32" to 3/16". ALL18207...\$83.99

Threaded Insert Adapter Tool



For #6, #8, #10, 1/4"-20" Inserts BSC90050...\$77.52

Rivet Adapter Tool For Cordless Drill



Use with 3/32", 1/8", 5/32", and 3/16" Rivets BSC90052...\$74.20

Thin Locknut Kit



This kit includes the following nylon - inserted locknuts in a compartment plastic case.

Coarse	Fine
• 1/4"-20 (30)	• 1/4"-28 (30)
• 5/16"-18 (25)	• 5/16"-24 (25)
• 3/8"-16 (20)	• 3/8"-24 (20)
• 7/16"-14 (15)	• 7/16"-20 (15)
• 1/2"-13 (15)	• 1/2"-20 (15)
BSCFS-1C	BSCFS-1F
\$14.95	\$14.95

Full Locknut Kit

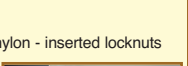

This kit includes the following nylon - inserted locknuts in a compartment plastic case.

Coarse	Fine
• 1/4"-20 (25)	• 1/4"-28 (25)
• 5/16"-18 (20)	• 5/16"-24 (20)
• 3/8"-16 (20)	• 3/8"-24 (20)
• 7/16"-14 (15)	• 7/16"-20 (15)
• 1/2"-13 (12)	• 1/2"-20 (12)
BSCFS-2C	BSCFS-2F
\$14.95	\$14.95

AN Washer Kit Stainless

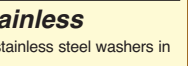

This kit includes the following stainless steel washers in a compartment plastic case.

Std (.060)	Thin (.030)
• 1/4" AN (35)	• 1/4" AN (35)
• 5/16" AN (35)	• 5/16" AN (35)
• 3/8" AN (30)	• 3/8" AN (30)
• 7/16" AN (25)	• 7/16" AN (25)
• 1/2" AN (20)	• 1/2" AN (20)
BSCFS-4	BSCFS-4T
\$13.95	\$13.95

Cap and Plug Plastic Kits (72 Piece)

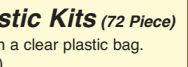

This kit is labeled resealable in a clear plastic bag.

• #3 Caps (6)	• #3 Plugs (6)
• #4 Caps (6)	• #4 Plugs (6)
• #6 Caps (6)	• #6 Plugs (6)
• #8 Caps (6)	• #8 Plugs (6)
• #10 Caps (6)	• #10 Plugs (6)
• #12 Caps (6)	• #12 Plugs (6)
BSCFS-AN72	
\$9.95	

Cap and Plug Plastic Kits (156 Piece)



This kit contains the following in a clear compartment case with a snap shut lid. Each size has its own compartment.

• #3 Caps (12)	• #3 Plugs (12)
• #4 Caps (12)	• #4 Plugs (12)
• #6 Caps (12)	• #6 Plugs (12)
• #8 Caps (12)	• #8 Plugs (12)
• #10 Caps (12)	• #10 Plugs (12)
• #12 Caps (12)	• #12 Plugs (12)
• #16 Caps (6)	• #16 Plugs (6)
BSCFS-AN156	
\$28.95	

Jet Nut Kit



Includes the following jet nuts in a compartment plastic case. • 10-32 (10) • 1/4"-28 (10) • 5/16"-24 (10) • 3/8"-24 (10) BSCFS-12...\$29.95

Black Locknut Kit Thin Ht



Includes the following locknuts - inserted locknuts in a plastic case. Fine • 10"-32 (30) • 1/4"-28 (30) • 5/16"-24 (25) • 3/8"-24 (20) • 1/2"-20 (20) BSCFS-15...\$20.95

Stover Locknut Kit

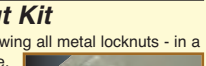

This kit includes the following all metal locknuts - in a compartment plastic case. Fine Thread • 1/4"-28 (25) • 5/16"-24 (20) • 3/8"-24 (20) • 7/16"-20 (15) • 1/2"-20 (15) BSCFS-10...\$16.95

Ladder Pin Kits



Steel Standard Kit. Feature: • 3/8" x 3.7" Pins (2) • 1/2" x 1.3" Pin (1) BSCFS-16...\$16.95

Torsion Bolt



Grade 8 with Nut BSCFS-17...\$4.50

Bumper Bolt Kits



This kit contains: • 10-32 thin locknuts (12) • 10-32 x 1-1/2" bumper bolts (12) Hex Head (Stainless)...BSCFS-18...\$5.50 Socket Head (Stainless)...BSCFS-19...\$5.50

Locknuts 1/2"-20



They are a thin series locknut. (25 Pack)....BSCFS-20A...\$6.50 (50 Pack)....BSCFS-20B...\$12.00

4' x 8' Plastic Sheets

HDPE sheet plastic is 4' x 8' & available in .100" thicknesses. .100" Thick White Plastic...ALL22460...\$49.99 .100" Thick Black Plastic...ALL22461...\$49.99 .100" Thick Red Plastic...ALL22462...\$49.99

Tin Snips

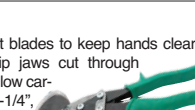

Durable tin snips have offset blades to keep hands clear of metal while cutting. Non-slip jaws cut through sheet alum & up to 18 gauge low carbon steel. Blade length 1-1/4", total tool length 9-1/4". Left Hand Cut, Red Grips...ALL11030...\$24.99 Right Hand Cut, Green Grips...ALL11031...\$24.99

Body Bolt Kit



Designed for easy install & removal, have 1/4"-20 thread, are 3/4" long & have a built-in captured washer. Nuts have built-in serrations which prevent loosening. Body Bolt Kit, 10-Pack...ALL18560...\$8.49 Body Bolt Kit, 50-Pack...ALL18560-50...\$34.99

Cleco Pliers



Unique tool easily installs & removes Cleco pins. ALL18220...\$9.99

Cleco Pins



They allow quick, easy installation and removal of sheet metal during fitting. Pins will work with thicknesses up to 1/4". 1/8" Cleco Pins (10-Pack)...ALL18222...\$8.49 1/8" Cleco Pins (25-Pack)...ALL18223...\$18.99 1/8" Cleco Pins (100-Pack)...ALL18224...\$74.99 3/16" Cleco Pins (10-Pack)...ALL18225...\$8.49 3/16" Cleco Pins (25-Pack)...ALL18227...\$18.99 3/16" Cleco Pins (100-Pack)...ALL18228...\$74.99

Plastic Lower Nose Support



Provides support between the front nose piece and front bumper of Dirt Late Models. 38" long supports are sold per nose half. 8" Width Black Support, 3/8" Thk., 3.7 Lbs. ALL23061...\$45.99

Spoiler Brackets

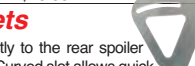

Alum spoiler bkts rivet directly to the rear spoiler and bolt to the side support. Curved slot allows quick spoiler adjustment. Bkts are solid flat & require a 90° bend for LH or RH use. Sold in 2-pks. 6-1/2" Tall Bkts For 8" Spoiler ALL23250...\$14.99

Gussets



Add support to tubing joints when building roll cages or chassis mts. Solid, 1 or 3 hole gussets are 1-7/8" tall x 1/8" thick. Reinforced gussets are 2-1/8" tall x 1/8" thick with a rolled edge for added strength. 1/8" Gusset Solid, 10-Pack...ALL22192...\$3.99



Sold Each



Steel Tapered Spacers (Add SPA in front of part # example: SPA0804)

Diameter	Length									
Dia. ID Dia. (OD)	1/4"	3/8"	1/2"	5/8"	3/4"	1"	1-1/4"	1-1/2"		
1/2" ID (1" OD)	0804\$1.38	0806\$1.38	0808\$1.38	0810\$1.65	0812\$1.65	0816\$1.65	0824\$2.09	0828\$2.20		
5/8" ID (1" OD)	1004\$1.38	1006\$1.38	1008\$1.38	1010\$1.65	1012\$1.65	1016\$1.65	1024\$2.09	1028\$2.20		
3/4" ID (1-1/8" OD)	1204\$1.76		1208\$1.76		1212\$1.76	1216\$1.76	1224\$2.09			

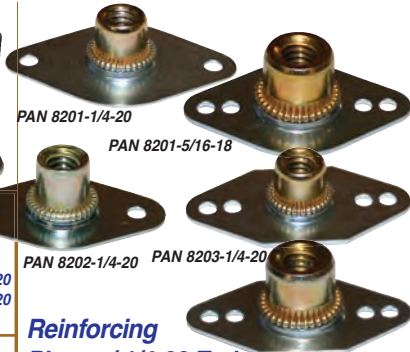

Reinforcing

Plate w/ 1/4-20 Zerk

PAN 8201-1/4-20.....Length 1.75" x Width 1.25"
 PAN 8201-5/16-18.....Length 1.75" x Width 1.25"
 PAN 8202-1/4-20.....Length 1.75" x Width 1.25"
 PAN 8203-1/4-20.....Length 1.75" x Width 0.920"
 PAN 8203-5/16-18.....Length 1.75" x Width 0.920"

BSC 90041.....1/4-20" Zerk Thread Insert
 Std Length 100 qty **BSC 90041**
 BSC 90041BULK.....1/4-20" Zerk Thread Insert Std
 Length - Each
 BSC 90042.....3/8-16" Zerk Thread Insert Std
 Length 100 qty
 BSC 90043.....10-24" Zerk Thread Insert Std
 Length 100 qty

Aluminum Tapered Spacers (Add SPA in front of part # example: SPA0404A)

Diameter	Length									
Dia. ID Dia. (OD)	1/4"	3/8"	1/2"	3/4"	1"					
1/4" ID (___ OD)	0404A\$1.10	0406A\$1.10	0408A\$1.10	0512A\$1.38	0616A\$1.38					
5/16" ID (5/8" OD)	0504A\$1.10	0506A\$1.10	0508A\$1.10	0612A\$1.38	0716A\$1.38					
3/8" ID (11/16" OD)	0604A\$1.10		0608A\$1.10	0712A\$1.38	0816A\$1.38					
7/16" ID (3/4" OD)	0704A\$1.10		0708A\$1.10	0812A\$1.38	0816A\$1.38					
1/2" ID (1" OD)	0804A\$1.10		0808A\$1.10	1012A\$1.65	1216A\$1.76	1224A\$2.09				
5/8" ID (1" OD)	1004A\$1.38		1008A\$1.38							
3/4" ID (1-1/8" OD)	1204A\$1.76		1208A\$1.76							
1/2" ID (1" OD)	0804ABK	0808ABK	0812ABK	0816ABK						
Black NEW	\$1.76	\$1.76	\$2.09	\$2.09						

Aluminum Flat Spacers

Sold Each

Aluminum

Thickness	1/8" Thick	3/16" Thick	1/4" Thick	5/16" Thick	3/8" Thick	7/16" Thick	1/2" Thick
3/8" ID x 11/16" OD	SPAF0602A	SPAF0603A	SPAF0604A	SPAF0605A	SPAF0606A	SPAF0607A	SPAF0608A \$1.10
7/16" ID x 3/4" OD	SPAF0702A	SPAF0703A	SPAF0704A	SPAF0705A	SPAF0706A	SPAF0707A	SPAF0708A \$1.10
1/2" ID x 1" OD	SPAF0802A	SPAF0803A	SPAF0804A	SPAF0805A	SPAF0806A	SPAF0807A	SPAF0808A \$1.38

Reducer

Bushings - Steel

Push it into your rod ends to reduce the bore size to meet your bolt size needs.

OD to ID

1/2" - 3/8" ...RED008-06	...\$1.10
5/8" - 1/2" ...RED010-08	...\$1.10
3/4" - 1/2" ...RED012-08	...\$1.10
3/4" - 5/8" ...RED012-10	...\$1.10

Sold Each

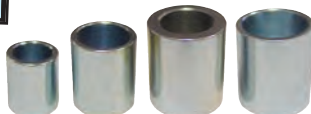

1" Aluminum

Reinforcing Washer for Bolts

1" washer with #10 Tapered Hole.....PAN8610 ...\$0.77
 1" washer for a #10 Bolt.....PAN8611...\$0.88
 3/4" #10 Flat Allen Bolt & Lock Nut ...PAN8612 ...\$0.14
 1" #10 Flat Allen Bolt & Lock NutPAN8613 ...\$0.14

Sold Each

PAN 8610 PAN 8611

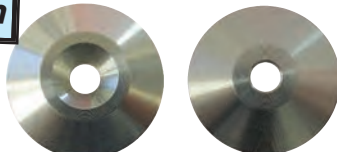

PAN 8618

PAN 8619

PAN 8619BK

Sold Each

1" Aluminum

Reinforcing Washer for Bolts

1" washer for a 1/4" BoltPAN8618\$0.88
 1" washer for a 1/4" Tapered BoltPAN8619\$0.75
 1" washer for a 1/4" Tapered Bolt - BlackPAN8619BK...\$1.50
 1" washer for a 1/4" Tapered Bolt - RedPAN8619RD...\$1.65



PAN 8620

PAN 8620BK

PAN 8625

Sold Each

1-1/4" Aluminum Reinforcing Washer for Bolts

1-1/4" washer for a 1/4" flat allen bolt.....PAN8620\$0.80
 1-1/4" black washer for 1/4" flat allen boltPAN8620BK.....\$1.35
 1-1/4" washer for a 5/16" Bolt.....PAN8625\$0.99
 3/4" x 1/4" Flat Allen Bolt & Lock NutPAN8622\$0.17
 3/4" x 1/4" Flat Allen Bolt & Lock Nut - BlackPAN8622BK.....\$0.21
 1" x 1/4" Flat Allen Bolt & Lock NutPAN8623\$0.19
 1" x 1/4" Flat Allen Bolt & Lock Nut - BlackPAN8623BK\$0.23



Spacer

Reducers

Requires 2 pieces

5/8" to 1/2" x 1/4" (1-1/4")
 Steel SPA0804-10.....\$1.65
 Aluminum SPA0804-10A...\$1.65

5/8" to 1/2" x 3/8" (1-1/2")
 Aluminum SPA0806-10A...\$1.65

5/8" to 1/2" x 1/2" (1-3/4")
 Steel SPA0808-10.....\$1.65
 Aluminum SPA0808-10A...\$1.65

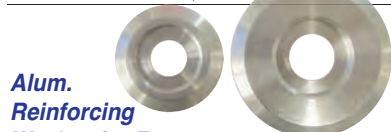

Alum.

Reinforcing

Washer for Fasteners

Spread out the clamping force of the fastener over more area.

5/16" washer 1" OD head.....PAN8400...\$1.10
 7/16" washer 1-1/2" OD head.....PAN8401...\$1.10



Back Up Washers .080" Thick

Aluminum (Qty 100)
 1/8"- Rivet x 1/2" : Dia...BSC90015\$14.95
 3/16"- Rivet x 1/2" : Dia...BSC90011\$6.30
 3/16"- Rivet x 5/8" : Dia...BSC90012\$8.40
 3/16"- Rivet x 1" : Dia...BSC90014\$10.50

Rivet Back Up

Plate and Washers

3/16" Rivet Back Up Alum .074 x 5/8 x 1.5"
 Qty 50BSC90010.....\$10.50
 Bulk Quantity...PAN8450.....\$1.00

WELD PLATES WITH RIVETED SPRING

PANELfast



Part #'s = PAN(Weld Plate)-(Spring)

8100 Weld Plate & 1" .250 Spr Rivited.....	PAN8100-5250.....	\$1.38
8100-E5 Weld Plate & 1" .250 Spr Rivited.....	PAN8100-E5250.....	\$2.38
8111 Weld Plate & 1" .250 Spr Rivited.....	PAN8111-5250.....	\$1.38
8115 Weld Plate & 1" .250 Spr Rivited.....	PAN8115-5250.....	\$1.38
8116 Weld Plate & 1" .250 Spr Rivited.....	PAN8116-5250.....	\$1.38
8121 Weld Plate & 1" .250 Spr Rivited.....	PAN8121-5250.....	\$1.38
8121 Weld Plate & 1" .325 Spr Rivited.....	PAN8121-5325.....	\$1.38
8122 Weld Plate & 1" .200 Spr Rivited.....	PAN8122-5200.....	\$2.38
8122 Weld Plate & 1" .225 Spr Rivited.....	PAN8122-5225.....	\$2.38
8122 Weld Plate & 1" .250 Spr Rivited.....	PAN8122-5250.....	\$2.38
8122 Weld Plate & 1" .275 Spr Rivited.....	PAN8122-5275.....	\$2.38
8122 Weld Plate & 1" .300 Spr Rivited.....	PAN8122-5300.....	\$2.38
8122 Weld Plate & 1" .325 Spr Rivited.....	PAN8122-5325.....	\$2.38
8130 Weld Plate & 1" .250 Spr Rivited.....	PAN8130-5250.....	\$1.38
8130-E5 Weld Plate & 1" .250 Spr Rivited.....	PAN8130-E5250.....	\$2.38
8131-E5 Weld Plate & 1" .250 Spr Rivited.....	PAN8131-E5250.....	\$2.38
8200 Weld Plate & 1-3/8" .375 Spr Rivited.....	PAN8200-6375.....	\$1.38
8200 Weld Plate & 1-3/8" .425 Spr Rivited.....	PAN8200-6425.....	\$1.38
8210 Weld Plate & 1-3/8" .375 Spr Rivited.....	PAN8210-6375.....	\$1.38
8220 Weld Plate & 1-3/8" .375 Spr Rivited.....	PAN8220-6375.....	\$1.38
8220 Weld Plate & 1-3/8" .400 Spr Rivited.....	PAN8220-6400.....	\$1.38
8220 Weld Plate & 1-3/8" .425 Spr Rivited.....	PAN8220-6425.....	\$1.38
8221 Weld Plate & 1-3/8" .375 Spr Rivited.....	PAN8221-6375.....	\$1.38
8221 Weld Plate & 1-3/8" .425 Spr Rivited.....	PAN8221-6425.....	\$1.38
8225 Weld Plate & 1-3/8" .375 Spr Rivited.....	PAN8225-6375.....	\$1.38
8350 Weld Plate & 1-3/8" .425 Spr Rivited.....	PAN8350-90-6425.....	\$1.79

NEW



Custom Order, Ask Sales for details.

WELD PLATES WITH FLUSH HEAD

Plates for Flush Head

Round or Square • Steel or Aluminum • Mill or Black

1-3/4" Round Steel Plate for Flush Head .030".....	PAN8450.....	\$1.00
1-3/4" Round Alum. Plate for Flush Head .040".....	PAN8450A.....	\$1.00
1-3/4" Round Steel Plate for Flush Head .030" - Black.....	PAN8451.....	\$1.30
1-3/4" Round Alum. Plate for Flush Head .040" - Black.....	PAN8451A.....	\$1.35
1-3/4" Round Steel Plate for Flush Head .030".....	PAN8452.....	\$1.96
1-1/2" Square Steel Plate for Flush Head .030".....	PAN8460.....	\$1.00
1-1/2" Square Alum. Plate for Flush Head .040".....	PAN8460A.....	\$1.00
1/2" Square Steel Plate for Flush Head .030" - Black.....	PAN8461.....	\$1.30
1/2" Square Alum. Plate for Flush Head .040" - Black.....	PAN8461A.....	\$1.35
1/2" Square Steel Plate for Flush Head .030".....	PAN8462.....	\$1.96



NEW

Plates with Self Eject Buttons

1-3/4" Round Alum. Plate w/ 7/16" Self Eject .500 Grip.....	PANEA6500-8450A.....	\$4.50
1-3/4" Round Alum. Plate w/ 7/16" Self Eject .550 Grip.....	PANEA6550-8450A.....	\$4.50
1-3/4" Round Alum. Plate w/ 7/16" Self Eject .500 Grip - Black.....	PANEBABK6500-8451A.....	\$4.50
1-3/4" Round Alum. Plate w/ 7/16" Allen Self Eject .500 Grip - Black.....	PANBEABK6500-8451A.....	\$4.50
1-3/4" Round Alum. Plate w/ 7/16" Self Eject .550 Grip - Black.....	PANEBABK6550-8451A.....	\$4.50
1-3/4" Round Alum. Plate w/ 7/16" Allen Self Eject .550 Grip - Black.....	PANBEABK6550-8451A.....	\$4.50
1/2" Square Alum. Plate w/ Self Eject .500 Grip - Black.....	PANEBABK6500-8461A.....	\$4.50
1/2" Square Alum. Plate w/ Allen Self Eject .500 Grip - Black.....	PANBEABK6500-8461A.....	\$4.50
1/2" Square Alum. Plate w/ Self Eject .550 Grip - Black.....	PANEBABK6550-8461A.....	\$4.50
1/2" Square Alum. Plate w/ Allen Self Eject .550 Grip - Black.....	PANBEABK6550-8461A.....	\$4.50
1/2" Square Steel Plate w/ Self Eject .500 Grip.....	PANEA6500-8462.....	\$4.50
1/2" Square Steel Plate w/ Self Eject .550 Grip.....	PANEA6550-8462.....	\$4.50
1-1/2" Square Alum. Plate w/ 7/16" Self Eject .500 Grip.....	PANEA6500-8460A.....	\$4.50
1-1/2" Square Alum. Plate w/ 7/16" Self Eject .550 Grip.....	PANEA6550-8460A.....	\$4.50



Forged Superlite FSLI/ST Caliper **wilwood**

FSLI4 and FSLI4/ST calipers provide the pad wear performance advantages of differential bore pistons with the option for ultimate heat protection using Thermlock pistons in the ST models.



Bore Size	Rotor Width	Part #	Price
1.88/1.75	1.25	4 Piston Lug Mount RHWIL120-11331	\$291.62
1.88/1.75	1.25	4 Piston Lug Mount LHWIL120-11332	\$291.62
1.88/1.75	1.25	4 Piston Lug Mount RHWIL120-11329	\$166.18
1.88/1.75	1.25	4 Piston Lug Mount LHWIL120-11330	\$166.18
1.88/1.75	0.81	4 Piston Lug Mount RHWIL120-11137	\$166.18
1.88/1.75	0.81	4 Piston Lug Mount LHWIL120-11138	\$166.18
1.75/1.75	1.25	FSLI 4 Piston Lug MountWIL120-11136	\$157.43
1.75/1.75	1.10	FSLI 4 Piston Lug MountWIL120-11135	\$157.43
1.75/1.75	0.81	FSLI 4 Piston Lug MountWIL120-11134	\$157.43
1.75/1.75	0.81	FSLI 4 Pi. Lug Side Inlet.....WIL120-11134-SI	\$172.43
1.62/1.62	1.25	FSLI 4 Piston Lug MountWIL120-11133	\$157.43
1.62/1.62	1.10	FSLI 4 Piston Lug MountWIL120-11132	\$157.43
1.62/1.62	0.81	FSLI 4 Piston Lug MountWIL120-11131	\$157.43
1.38/1.38	1.25	FSLI 4 Piston Lug MountWIL120-11130	\$157.43
1.38/1.38	1.10	FSLI 4 Piston Lug MountWIL120-11129	\$157.43
1.38/1.38	0.81	FSLI 4 Piston Lug MountWIL120-11128	\$157.43
1.25/1.25	1.25	FSLI 4 Piston Lug MountWIL120-11127	\$157.43
1.25/1.25	0.81	FSLI 4 Piston Lug MountWIL120-11126	\$157.43
1.12/1.12	0.81	FSLI 4 Piston Lug MountWIL120-11125	\$157.43

wilwood

Nickel Plated

Bore Size ..Rotor Width

1.88/1.75	0.81	4 Piston Lug Mount RHWIL120-13826-N	\$281.92
1.88/1.75	0.81	4 Piston Lug Mount LHWIL120-13827-N	\$281.92
1.88/1.75	1.25	4 Piston Lug Mount RHWIL120-13263-N	\$406.91
1.88/1.75	1.25	4 Piston Lug Mount LHWIL120-13264-N	\$406.91



Polymatrix 7420 Pad

Axle Set Pin ..Pad Type

WIL15A-5938K	A	\$158.46
WIL15B-5939K	B	\$138.54
WIL15C-6853K	C	\$149.00
WIL15E-6084K	E	\$95.85
WIL15H-8114K	H	\$181.04
WIL15Q-6829K	Q	\$105.59
WIL150-8854K	BP-10	\$68.84
WIL150-9416K	BP-20	\$71.94

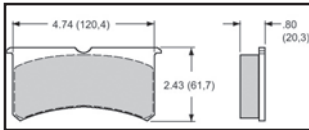

WIL150-9864K	BP-30	\$130.00
WIL150-12245K	BP-40	\$143.69

Superlite Radial Mount

It mounts the Forged Superlite Radial Mount calipers to 3.50" center to center lug mount. Mounting height is optimized to allow mounting this caliper in all apps.

WIL250-6309\$57.43



GM III Single Piston Floater Caliper

It is the most rigid, highest torque, lightweight aluminum caliper with weights starting at 3.36 pounds. Requires use of hardened Wilwood slide pins (sold separately), request WIL230-0619 (slide pin kit) contains 4 slide pins, enough for two calipers.



Bore Size ..Rotor Width Description

2.75	1.25	1 Piston Floating Mount.....WIL120-5289	\$118.69
2.75	1.00	1 Piston Floating Mount.....WIL120-5861	\$124.94
2.75	0.81	1 Piston Floating Mount.....WIL120-5288	\$118.69
2.38	1.25	1 Piston Floating Mount.....WIL120-5344	\$118.69
2.38	0.81	1 Piston Floating Mount.....WIL120-5343	\$118.69

Polymatrix D52

Axle Set Pin.....Pad Type

WIL15A-5737K	A	\$135.11
WIL15B-3994K	B	\$127.80
WIL15C-4419K	C	\$123.00
WIL15E-6102K	E	\$91.87
WIL15H-8232K	H	\$134.94
WIL15Q-6830K	Q	\$99.79
WIL150-8939K	BP-10	\$55.29
WIL150-9421K	BP-20	\$61.94
WIL150-12249K	BP-40	\$133.09

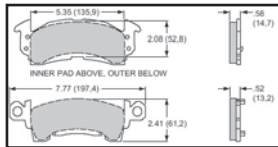

GM Metric Iron Caliper

These all new cast, not rebuilt iron calipers are bolt-on replacements for 1978 and later GM Metric calipers widely used in "spec" racing categories and low cost disc brake conversions. Requires use of hardened Wilwood slide pins (sold separately), request WIL230-0619 (slide pin kit) contains 4 slide pins, enough for 2 calipers.



Bore.....Rotor

Size	Width	Description	Part #	
2.75	1.00	1 Piston Floating MountWIL120-8924	\$71.94
2.00	1.00	1 Piston Floating MountWIL120-9333	\$71.94

Polymatrix D52

Axle Set Pin.....Pad Type

WIL15A-6219K	A	\$135.11
WIL15B-3998K	B	\$127.80
WIL15C-4420K	C	\$115.00
WIL15E-6103K	E	\$91.87
WIL15Q-6831K	Q	\$99.79
WIL150-8936K	BP-10	\$55.29
WIL150-9422K	BP-20	\$61.94
WIL150-12250K	BP-40	\$122.49

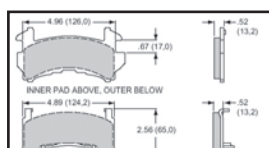

Billet Narrow Dynalite Radial

Starting at 2.70 pounds, this compact and proven performer is now available in a radial mt configuration.



Bore Size ..Rotor Width

1.75/1.75	0.38	4 Piston Rad Side Inlet..WIL120-6453-SI\$144.00
		Radial Mt Bkt Kit - 3.50" Mt Center, 12.19" Rotor Dia..WIL250-13365\$68.69

Billet Narrow Dynalite Radial Mt Nickel Plated

Bore Size ..Rotor W.....4 Piston Radial Mt Side Inlet

1.75/1.75	0.81WIL120-13406-N\$191.65
1.75/1.75	0.38WIL120-13405-N\$191.65
		Radial Mt Bkt Kit - 3.50" Mt Center, 12.19" Rotor Dia..WIL250-13365\$68.69



Polymatrix 7816 Pad

Axle Set Pin.....Pad Type

WIL150-10290K	CM	\$131.58
WIL15A-7263K	A	\$126.66
WIL15B-7264K	B	\$123.24
WIL15E-7266K	E	\$88.12
WIL15Q-7268K	Q	\$103.09

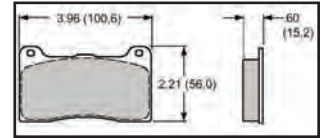

Radial Mount 3.5" Bolt-On Mount. Primarily for birdcage or Teo splined remote brackets.

WIL250-13365\$68.69



Forged Narrow Dynalite Caliper

They are the strongest calipers in the class. FNLD calipers are a direct replacement for all previous Wilwood NDL's and similar competitive brands with 3.50" centered mounting tabs.



Bore Size ..Rotor Width

1.75/1.75	1.25	4 Piston Lug Mount.....WIL120-11573\$116.94
1.75/1.75	0.81	4 Piston Lug Mount.....WIL120-11572\$116.94
1.75/1.75	0.81	4 Piston Lug-Side Inlet..WIL120-11572-SI\$129.44
1.75/1.75	0.38	4 Piston Lug Mount.....WIL120-11571\$116.94
1.75/1.75	0.38	4 Piston Lug-Side Inlet..WIL120-11571-SI\$129.44
1.38/1.38	1.25	4 Piston Lug Mount.....WIL120-11576\$116.94
1.38/1.38	0.81	4 Piston Lug Mount.....WIL120-11575\$116.94
1.38/1.38	0.38	4 Piston Lug Mount.....WIL120-11574\$116.94
1.12/1.12	1.25	4 Piston Lug Mount.....WIL120-11579\$121.19
1.12/1.12	0.81	4 Piston Lug Mount.....WIL120-11578\$121.19
1.12/1.12	0.81	4 Piston Lug Mt-Polish..WIL120-11578-P\$178.68
1.12/1.12	0.38	4 Piston Lug Mount.....WIL120-11577\$121.19
1.12/1.12	0.38	4 Piston Lug Mt-Polish..WIL120-11577-P\$178.68
1.62/1.62	0.38	4 Piston Lug Mount.....WIL120-14330\$116.94
1.62/1.62	0.81	4 Piston Lug Mount.....WIL120-14331\$116.94
1.62/1.62	1.00	4 Piston Lug Mount.....WIL120-14332\$116.94
1.62/1.62	1.25	4 Piston Lug Mount.....WIL120-14333\$116.94
1.75/1.75	1.00	4 Piston Lug Mount.....WIL120-15254\$116.94
1.38/1.38	1.00	4 Piston Lug Mount.....WIL120-15255\$116.94

Polymatrix 7816 Pad

Axle Set Pin ..Pad Type

WIL15A-7263K	A	\$126.66
WIL15B-7264K	B	\$123.24
WIL15E-7266K	E	\$88.12
WIL15Q-7268K	Q	\$103.09
WIL150-8946K	BP-10	\$47.00
WIL150-9419K	BP-20	\$56.18
WIL150-12248K	BP-40	\$122.79
WIL150-9753K	SM for Tit..	\$122.86

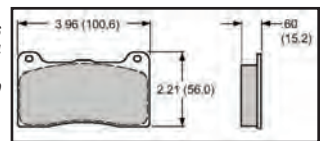

WIL150-10290KSM for Tit..\$127.00

Narrow Dynapro Lug Mount Caliper

It represent the next generation of calipers available as an upgrade or direct replacement for the popular Narrow Mt Dynalite model series with 3.50" mounting. NDP calipers combine superior strength with several new perf enhancements to make these the best "Dyna" series calipers ever built.



Bore Size ..Rotor Width

1.75/1.75	0.38	4 Piston Lug-Side Inlet..WIL120-9734-SI\$133.00
1.62/1.62	0.81	4 Piston Lug Mount.....WIL120-9732\$124.00
1.62/1.62	0.38	4 Piston Lug Mount.....WIL120-9734\$129.00
1.38/1.38	1.25	4 Piston Lug Mount.....WIL120-9729\$124.00
1.38/1.38	0.38	4 Piston Lug Mount.....WIL120-9726\$124.00
1.25/1.25	1.25	4 Piston Lug Mount.....WIL120-10522\$149.00

Polymatrix 7816 Pad

Axle Set Pin.....Pad Type

WIL15A-7263K	A	\$126.66
WIL15B-7264K	B	\$123.24
WIL15E-7266K	E	\$88.12
WIL15H-10645K	H	\$131.16
WIL15Q-7268K	Q	\$103.09
WIL150-8946K	BP-10	\$47.00
WIL150-9419K	BP-20	\$56.18
WIL150-12248K	BP-40	\$122.79
WIL150-9753K	SM for Tit..	\$122.86

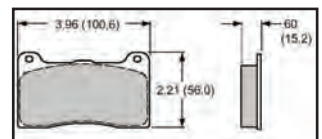

*These pads have been modified.

Billet Dynapro Lug Mt Caliper

A sleek profile with superior strength and a fully detailed machined finish provide the perf and looks for competition or show.

Bore Size ..Rotor Width

1.75/1.75...1.25	4 Piston Lug Mount.....	WIL120-9691.....	\$157.43
1.75/1.75...1.00	4 Piston Lug Mount.....	WIL120-9692.....	\$163.68
1.75/1.75...0.81	4 Piston Lug Mount.....	WIL120-9693.....	\$157.43
1.75/1.75...0.81	4 Piston Lug Side Inlet.....	WIL120-9693-SI.....	\$147.41
1.75/1.75...0.50	4 Piston Lug Mount.....	WIL120-9694.....	\$163.68
1.75/1.75...0.38	4 Piston Lug Mount.....	WIL120-9695.....	\$157.43
1.75/1.75...0.38	4 Piston Lug Mount.....	WIL120-9695-SI.....	\$147.41
1.38/1.38...1.25	4 Piston Lug Mount.....	WIL120-9701.....	\$157.43
1.38/1.38...1.00	4 Piston Lug Mount.....	WIL120-9702.....	\$163.68
1.38/1.38...0.81	4 Piston Lug Mount.....	WIL120-9703.....	\$157.43
1.38/1.38...0.81	4 Piston Lug Side Inlet.....	WIL120-9703-SI.....	\$154.91
1.38/1.38...0.50	4 Piston Lug Mount.....	WIL120-9704.....	\$163.68
1.38/1.38...0.38	4 Piston Lug Mount.....	WIL120-9705.....	\$157.43
1.38/1.38...0.38	4 Piston Lug Side Inlet.....	WIL120-9705-SI.....	\$154.91
1.00/1.00...0.81	4 Piston Lug Mount.....	WIL120-9706.....	\$169.93

Polymatrix 7812 Pad

Axle Set Pin.....Pad Type	Price
WIL15A-9835K.....A.....	\$121.19
WIL15B-9836K.....B.....	\$119.35
WIL15E-9837K.....E.....	\$86.88
WIL15H-10644K.....H.....	\$123.10
WIL15Q-10385K.....Q.....	\$97.24
WIL150-9136K.....BP-10.....	\$43.50
WIL150-9418K.....BP-20.....	\$55.48

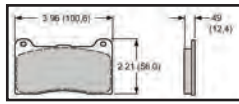

WIL150-12247KBP-40.....\$121.46

Dynapro 4 Piston Radial Mt

As light as 3.58 lbs, the Dynapro is for a broad range of sports, rally, & off-road driving apps.

Bore Size ..Rotor Width

1.75/1.75...1.00	4 Piston Radial Mount.....	WIL120-8545.....	\$183.48
1.75/1.75...0.81	4 Piston Rad Side Inlet.....	WIL120-8544-SI.....	\$159.00
1.75/1.75...0.50	4 Piston Rad Side Inlet.....	WIL120-8543-SI.....	\$169.00
1.62/1.62...1.00	4 Piston Radial Mount.....	WIL120-8542.....	\$183.48
1.62/1.62...0.81	4 Piston Radial Mount.....	WIL120-8541.....	\$183.48
1.38/1.38...1.00	4 Piston Radial Mount.....	WIL120-8539.....	\$183.48
1.38/1.38...0.81	4 Piston Radial Mount.....	WIL120-8538.....	\$183.48
1.25/1.25...1.00	4 Piston Radial Mount.....	WIL120-8536.....	\$183.48
1.25/1.25...0.50	4 Piston Radial Mount.....	WIL120-8534.....	\$183.48

Polymatrix 7816 Pad

Axle Set Pin.....Pad Type	Price
WIL15A-7263K.....A.....	\$126.66
WIL15B-7264K.....B.....	\$123.24
WIL15E-7266K.....E.....	\$88.12
WIL15H-10645K.....H.....	\$131.16
WIL15Q-10385K.....Q.....	\$97.24
WIL150-8946K.....BP-10.....	\$47.00
WIL150-9419K.....BP-20.....	\$56.18
WIL150-12248K.....BP-40.....	\$122.79

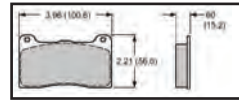

WIL150-9753KSM.....\$122.86

Forged Dynalite Caliper

They have wide spread application over many forms over motorsports. It serves as the base model in the majority of Bolt-On Disc Brake Kits. Add 5.25 center on center mt.

Bore Size ..Rotor Width

1.75/1.75...1.25	4 Piston Lug Mount.....	WIL120-6814.....	\$112.44
1.75/1.75...1.00	4 Piston Lug Mount.....	WIL120-6815.....	\$124.94
1.75/1.75...0.81	4 Piston Lug Mount.....	WIL120-6816.....	\$112.44
1.75/1.75...0.50	4 Piston Lug Mount.....	WIL120-6817.....	\$124.94
1.75/1.75...0.38	4 Piston Lug Mount.....	WIL120-6818.....	\$112.44
1.62/1.62...1.00	4 Piston Lug Mount.....	WIL120-6810.....	\$124.94
1.62/1.62...1.00	4 Piston Lug Mt-Polish.....	WIL120-6795-P.....	\$171.73
1.62/1.62...0.81	4 Piston Lug Mount.....	WIL120-6811.....	\$124.94
1.62/1.62...0.81	4 Piston Lug Mt-Polish.....	WIL120-6796-P.....	\$159.25
1.62/1.62...0.38	4 Piston Lug Mount.....	WIL120-6813.....	\$124.94
1.62/1.62...0.38	4 Piston Lug Mt-Polish.....	WIL120-6798-P.....	\$171.73
1.38/1.38...1.25	4 Piston Lug Mount.....	WIL120-6804.....	\$124.94
1.38/1.38...1.00	4 Piston Lug Mount.....	WIL120-6805.....	\$124.94
1.38/1.38...0.81	4 Piston Lug Mount.....	WIL120-6806.....	\$112.44
1.38/1.38...0.50	4 Piston Lug Mount.....	WIL120-6807.....	\$124.94
1.38/1.38...0.50	4 Piston Lug Mt-Polish.....	WIL120-6792-P.....	\$171.73
1.38/1.38...0.38	4 Piston Lug Mount.....	WIL120-6808.....	\$112.44

Polymatrix 7112 Pad

Axle Set Pin.....Pad Type	Price
WIL15A-5734K.....A.....	\$100.59
WIL15B-3991K.....B.....	\$99.51
WIL15C-4415K.....C.....	\$86.00
WIL15E-6096K.....E.....	\$72.56
WIL15H-8291K.....H.....	\$102.30
WIL15Q-6824K.....Q.....	\$79.29
WIL150-8850K.....BP-10.....	\$43.45

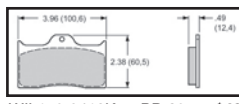

WIL150-9413KBP-20.....\$48.67
WIL150-12243K.....BP-40.....\$96.84

Forged Superlite Internal 4 ST

These are for hard braking on dirt and asphalt ovals and a wide range of off-road, rally and road course apps.

Bore Size ..Rotor Width

1.88/1.75...0.81	Right Hand.....	WIL120-13155.....	\$291.62
1.88/1.75...0.81	Left Hand.....	WIL120-13156.....	\$291.62

Polymatrix 7420 Pad

Axle Set Pin.....Pad Type	Price
WIL15A-5938K.....A.....	\$158.46
WIL15B-5939K.....B.....	\$138.54
WIL15C-6853K.....C.....	\$149.00
WIL15E-6084K.....E.....	\$95.85
WIL15H-8114K.....H.....	\$181.04
WIL15Q-6829K.....Q.....	\$105.59
WIL150-8854K.....BP-10.....	\$68.84

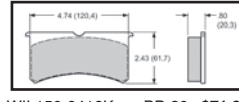

WIL150-9416KBP-20.....\$71.94
WIL150-9864KBP-30.....\$130.00

Dynapro Single Caliper

It is the newest generation of calipers available as an upgrade or replacement for applications previously using the Dynalite Single (DLS) series. DPS calipers combine superior strength with performance enhancements to make these the best "Dyna" series calipers ever.

Bore Size ..Rotor W. DynaPro Single

1.75/1.75...0.38	2 Piston 3.25" Lug Mount.....	WIL120-9687.....	\$90.60
1.75/1.75...0.38	2 Piston 3.25" Lug Mt-Polish.....	WIL120-9687-P.....	\$153.70
1.75/1.75...0.38	2 Piston 3.25" Lug Mt-LW.....	WIL120-10188.....	\$90.60
1.75/1.75...0.38	2 Piston 3.75" Lug Mount.....	WIL120-9689.....	\$90.60
1.75/1.75...0.38	2 Piston 3.75" Lug Mt-Polish.....	WIL120-9689-PLP.....	\$156.20
1.38/1.38...0.38	2 Piston 3.25" Lug Mount.....	WIL120-9688.....	\$94.35
1.38/1.38...0.38	2 Piston 3.75" Lug Mount.....	WIL120-9690.....	\$94.35

Bore Size ..Rotor W. Dynalite Single

Part #.....Price			
1.75/1.75...0.38	2 Piston 3.25" Lug Mount.....	WIL120-4060.....	\$104.19
1.75/1.75...0.38	2 Piston 3.75" Lug Mount.....	WIL120-4062.....	\$104.18

DynaPro Single Nickle Plated

Bore.....Rotor Size.....Width	Price		
1.75/1.75...0.38	2 Piston 3.25" Lug Mt	WIL120-10188-N.....	\$102.44

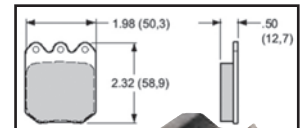

GP320 Caliper

Weighing just 1.70 pounds, it was purpose built as an upgrade with increased pad size over 2 piston calipers on LW open wheeled racers. The GP 320 bridge configuration will accommodate rotors between .75" and .81" thick, with overall diameters between 9.00" & 11.50".

Bore Size ..Rotor Width

1.25/1.25...0.81	4 Piston Lug Mount RH.....	WIL120-10714.....	\$148.47
1.25/1.25...0.81	4 Piston Lug Mount LH.....	WIL120-10715.....	\$148.47
1.25/1.25...0.24	4 Piston Lug Mount RH.....	WIL120-8524.....	\$134.97
1.25/1.25...0.24	4 Piston Lug Mount LH.....	WIL120-8525.....	\$134.97

Polymatrix 6211 Pad

Axle Set Pin.....Pad Type	Price
WIL15H-8596K.....H.....	\$106.21

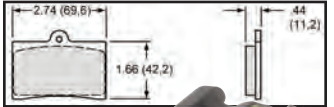

Dynalite Single Floater Caliper

Weighing 1.40 lbs, the caliper uses the same .49" thick, 1.1 cubic inch Dynalite Single quick change pads. Multiple 1/8-27 NPT inlet & bleed screw locations allow for versatile mounting positions.

Bore Size ..Rotor Width

1.75...0.38	1 Piston Floating Mount.....	WIL120-3277.....	\$99.93
1.75...0.25	1 Piston Floating Mount.....	WIL120-2498.....	\$99.93

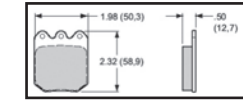

WIL150-12242KBP-40.....\$76.54
WIL150-9766KAlum Rotor \$55.29

Forged Superlite 6/ST Radial Mt

6 piston differential bore configuration provides balanced loading for even pad wear in sustained high heat.

Bore Size ..Rotor Width

1.62/1.12...1.12	Right Hand.....	WIL120-13267-N.....	\$469.40
1.62/1.12...1.12	Left Hand.....	WIL120-13268-N.....	\$469.40

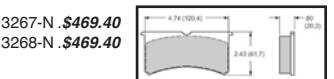

Polymatrix 7420 Pad

Axle Set Pin.....Pad Type	Price
WIL150-12245K.....BP-40.....	\$143.69
WIL15A-5938K.....A.....	\$158.46
WIL15B-5939K.....B.....	\$138.54
WIL15H-8114K.....H.....	\$181.04

Powerlite Radial Mt Caliper

It starts at 2.26 lbs with a sleek profile, superior strength, lightweight and durable in higher temp situations.

Bore Size ..Rotor Width

1.38/1.38...0.86	4 Piston Radial Mount.....	WIL120-8729.....	\$128.67
1.38/1.38...0.50	4 Piston Radial Mount.....	WIL120-8726.....	\$128.67
1.25/1.25...0.86	4 Piston Radial Mount.....	WIL120-8728.....	\$128.67
1.25/1.25...0.50	4 Piston Radial Mount.....	WIL120-8725.....	\$128.67
1.00/1.00...0.86	4 Piston Radial Mount.....	WIL120-8727.....	\$128.67
1.00/1.00...0.50	4 Piston Radial Mount.....	WIL120-8724.....	\$128.67

Polymatrix 7912 Pad

Axle Set Pin.....Pad Type	Price
WIL15A-8809K.....A.....	\$87.89
WIL15B-8949K.....B.....	\$119.35
WIL15E-8810K.....E.....	\$67.84
WIL15H-8811K.....H.....	\$90.59
WIL15Q-8812K.....Q.....	\$70.61
WIL150-8813K.....BP-10.....	\$57.92
WIL150-9420K.....BP-20.....	\$64.92
WIL150-12842K.....BP-40.....	\$104.74

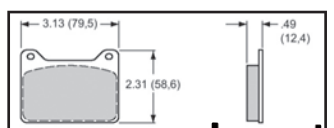

NE DIRT Modified Bkt
WIL250-9656.....\$66.56

PS-1 Caliper

The PS-1 Caliper is compact, lightweight (.93 pounds) and combines the strength of cast aluminum construction with a sleek low profile design. This caliper utilizes two stainless steel deep cup pistons to minimize heat transfer from the .30" thick pad to the brake fluid while employing high temperature square piston seals to control piston retraction. Internal crossover brake fluid passages eliminate the use of external crossover tubes. The PS-1 fits rotors with diameters ranging from 6.00" to 9.00", thickness sizes from .15" to .20".



Bore Size ..Rotor Width

1.12.....0.19.....2 Piston Lug Mount - RH.....WIL120-8373 ..\$76.44
1.12.....0.19.....2 Piston Lug Mount - LH.....WIL120-8374 ..\$76.44
1.00.....0.19.....2 Piston Lug Mount - RH.....WIL120-5453 ..\$76.44
1.00.....0.19.....2 Piston Lug Mount - LH.....WIL120-5456 ..\$76.44

PS-1 Pad

Axle Set Pin.....Pad Type
WIL150-4091K.....PS-1 Sintered Metallic \$43.11

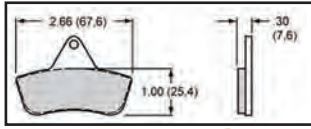

Billet Go-Kart Caliper

Our Kart/Jr. Dragster Caliper is designed specifically for racing. A unique self retracting and adjusting piston system has been incorporated which enables the piston to retract as the brake line pressure is reduced. The caliper can be mounted on either side of the vehicle and comes in three rotor widths. At just 1.20 pounds, the caliper comes with high performance, high friction brake pads. Additional features include deep cup stainless steel piston for reduced heat transfer, cotter pin, pad retainer, internal fluid passage and blue anodized finish. A specifically designed master cylinder is also available for use with this caliper.



Bore Size ..Rotor Width

1.00.....0.50.....2 Piston Body Mount.....WIL120-5499.....\$118.68
1.00.....0.19.....2 Piston Body Mount.....WIL120-5750.....\$118.68



Polymatrix 4308 Pad

Axle Set Pin.....Pad Type
WIL150-5602K.....2 Pk Sintered Metallic.....\$39.95

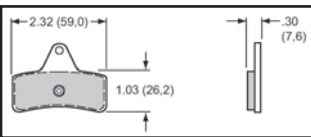

Billet Spot Caliper

Wilwood's 1.75" diameter single piston Billet Spot Caliper is ideal for Micro and Mini Sprint, Kart, Off Road, Motorcycle, Drag Race Spindle Mount and industrial applications. Designed for light duty use, this floating caliper weighs just 1.20 pounds and holds a round .25" thick, .7 cubic inch brake pad, and accommodates rotors from 6.00" to 13.00" diameter and widths starting at .12". Maximum rotor width can be adjusted by specific bracket and spacer dimensions. The pads are held in place by stainless steel 10-24 x .38" long flat head cap screw (screws are included), and the caliper is available black anodized.



Bore Size ..Rotor Width

1.75.....0.25.....1 Piston Floating Mount...WIL120-1064.....\$124.92
1.75.....0.25.....1 Piston Floating-Polish...WIL120-1064-P...\$149.92

Spot 10 BP-10 Smart Pad

Axle Set Pin.....Pad Type
WIL150-1251K.....Spot 10 BP-10 \$32.85

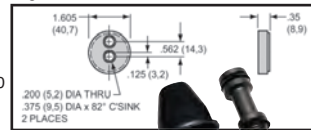

Master Cylinder Rebuild Kits

1-1/32" tandem.....WIL260-2414 ..\$32.81
3/4" remote.....WIL260-3881 ..\$18.69
7/8" remote.....WIL260-3882 ..\$18.69
1" remote.....WIL260-3883 ..\$18.69
1 1/8" remote.....WIL260-3884 ..\$18.69



Square Caliper O-Ring Kits

1.75"/1.62"(4pk) ..SL.....WIL130-3082 ..\$9.85
1.75" (4pk).....DLS/DL/SL WIL130-2655 ..\$8.05
1.62" (6pk).....GN.....WIL130-2656 ..\$12.07
1.38" (4pk).....DL/SL.....WIL130-2658 ..\$8.05



Round O-Ring Kits (4-pack)

1.75".....DLS/DL/SL WIL130-0047 ..\$9.85
1.38".....DL/SL2.....WIL130-0053 ..\$9.85
2.75".....GM.....WIL130-4955 ..\$9.85



Differential Bore O-Ring Kits

BSL.....WIL130-5100 ..\$9.85
Tube Adapters (4 pack).....WIL220-0628 ..\$6.81



Brake Pad Compounds

A	Perf. Range Data Heat Range: X-High Cold Torque: X-High Hot Torque: X-High Wear Rate: Low	Immediate cold response with highest friction values at all temps. Severe duty use on oval tracks and road courses or other applications that require immediate high response at low temps. Long wear rate for severe duty, sustained high temp braking. Compatible with all iron, steel, and titanium rotors.
BP-40	Perf. Range Data Heat Range: X-High Cold Torque: Medium Hot Torque: X-High Wear Rate: Medium-Low	Improved friction formula for heavy braking asphalt ovals, extreme braking on dirt, and all types of off-road and road course apps. Predictable & linear response with excellent modulation on iron & titanium rotors. Long wear rate with iron & steel rotors. High torque on titanium rotors. Very high heat fade resistance.
H	Perf. Range Data Heat Range: X-High Cold Torque: High Hot Torque: X-High Wear Rate: Low	Smooth initial engagement with a linear increase as heat and pressure rise. Severe duty use for road courses and hard braking pavement/dirt ovals. Predictable response with excellent modulation at all temps. Long wear rate for durability in sustained high heat. Compatible with all iron and steel rotors. High torque on stainless steel rotors.
BP-30	Perf. Range Data Heat Range: High Cold Torque: Medium Hot Torque: High Wear Rate: Medium-Low	Improved friction formula for intermediate asphalt ovals and drag braking dirt tracks. Light to intermediate duty road courses. Beds quickly with low rotor abrasion & long wear. Compatible with all iron, steel, & titanium rotors.
B	Perf. Range Data Heat Range: High Cold Torque: Medium Hot Torque: High Wear Rate: Medium	Traditional formulae for asphalt LMIs, modifieds, and sprints. Modifieds, late models, and other hard braking dirt applications. Intermediate weight road course, auto-cross, rally. Beds easily and fully compatible with all iron, steel, and rotors.
C	Perf. Range Data Heat Range: X-High Cold Torque: Low Hot Torque: Medium Wear Rate: Low	Gradual rise from medium to medium high torque as temps increase. Long wear and high temp fade resistance. Tuning pad for reduced response in med to high temp ranges. Reduced friction after to B. Compatible with all iron, steel, & titanium rotors.
CM	Perf. Range Data Heat Range: High Cold Torque: Medium Hot Torque: Medium-High Wear Rate: Low	Composite metallic compound for high temp durability on titanium and other low conductive alloy rotors. Long wear rates and high fade resistance in sustained heat. Baseline for inboard sprint brakes with titanium or stainless rotors.
E	Perf. Range Data Heat Range: Medium Cold Torque: Medium Hot Torque: Medium Wear Rate: Medium	Consistent, linear response through temperature range. Baseline for light to intermediate dirt applications with vented iron rotors. Drag racing with steel rotors. Auto-cross and lighter duty road racing.
BP-10	Perf. Range Data Heat Range: Medium Cold Torque: Medium Hot Torque: Medium Wear Rate: Medium	High performance street compound with improved friction, longer wear and lower dust levels than standard replacement pads. Beds quickly and provides fast response without high rotor abrasion. Baseline pad compound for most disc conversion and upgrade kits.
BP-20	Perf. Range Data Heat Range: Medium-High Cold Torque: Medium Hot Torque: Medium-High Wear Rate: Medium	High performance street compound with increased friction and a wider temperature range over BP-10. Beds quickly and provides fast response without high rotor abrasion. Baseline pad for track oriented street cars.
Q	Perf. Range Data Heat Range: Medium-Low Cold Torque: Medium Hot Torque: Medium Wear Rate: Medium	High performance ceramic based street formula. Lowest dust and noise. Compatible with all types of steel or iron rotors. Aluminum rotors for racing.
PM	Perf. Range Data Heat Range: High Cold Torque: Medium Hot Torque: Med-Med Wear Rate: Usage Based	True dual-sport Pro Matrix perf street & track compound. Quiet running with lowered dust than OE compounds. Unique composite formula provides clean, quiet, & long running on the street, with high friction and high temp fade resistance to withstand extreme braking cycles during auto-cross and track day events.
A.) Bridge Bolt Kits	1.38" rotor.....GNIII.....WIL230-3029 ..\$15.46 1.25".....SLIII.....WIL230-3052 ..\$15.46 .81".....SLIII.....WIL230-3079 ..\$15.46 7/16"-20x3 3/8" GM (4-pk).....WIL230-0619 ..\$14.17	A.
B.) Cotter Pins	3/16"x 4".....WIL180-0052 ..\$9.97 1/8"x 2 1/2".....WIL180-0054 ..\$8.69 1/8"x 3".....WIL180-0055 ..\$8.69 1/8"x 3 1/2".....WIL180-0056 ..\$8.69	B.
C.) C-Clips	.38" rotor.....DL.....WIL180-3861 ..\$9.99 .81".....DL.....WIL180-3862 ..\$9.99 1.25".....DL.....WIL180-3863 ..\$9.99	C.
D.) Brake Caliper Pistons	1.12 x 1.05 ss replaces WIL200-6307...WIL200-7513 ..\$10.75 1.25 x 1.05 ss replaces WIL200-4655...WIL200-7514 ..\$10.75 1.38 x 1.03 ss replaces WIL200-3176...WIL200-7516 ..\$10.75 1.38 x 0.88 ss replaces WIL200-1117...WIL200-7518 ..\$10.75 1.62 x 1.03 ss replaces WIL200-1114...WIL200-7519 ..\$10.75 1.62 x 0.88 ss replaces WIL200-4106; WIL200-7215...WIL200-7520 ..\$10.75 1.88 x 1.03 ss replaces WIL200-5037...WIL200-7521 ..\$10.75 1.88 x 1.07 ss replaces WIL200-3032...WIL200-7522 ..\$10.75 1.75 x 0.88 ss replaces WIL200-1118...WIL200-7528 ..\$10.75 1.75 x 1.00 ss replaces WIL200-1116...WIL200-7530 ..\$10.75 1.75 x 1.03 ss replaces WIL200-3062...WIL200-7531 ..\$10.75 1.75 x 1.08 ss replaces WIL200-3236...WIL200-7532 ..\$10.75	D.
E.) Bleeders (4-pk)WIL220-0627 ..\$9.37	E.

GT Curved Vane Rotor

They are manufactured from a proprietary iron alloy developed to withstand extreme temps with the highest possible degree of resistance against distortion, warping, cracking, and wear. The formulation for this alloy is a derivative of technology and materials that were significant in the development of the extreme duty military spec rotors that are manufactured by Wilwood. Every Spec 37 rotor is precision machined to less than .001" run-out, flatness, and parallelism.



Dia.	Width	Bolt Circle	Hole Type	Far Side I.D.	Lug I.D.	Weight LBS	RH/LH	Part #	Price
12.19"	1.25"	8 x 7.00"	0.313"	8.41"	6.53"	12.7	RH	WIL160-11839	\$124.94
12.19"	1.25"	8 x 7.00"	0.313"	8.41"	6.53"	12.7	LH	WIL160-11840	\$124.94
12.19"	0.81"	8 x 7.62"	5/16-24	8.41"	7.13"	9.3	RH	WIL160-12293	\$137.42
12.19"	0.81"	8 x 7.62"	5/16-24	8.41"	7.13"	9.3	LH	WIL160-12294	\$137.42
12.19"	0.81"	8 x 7.00"	0.325"	8.34"	6.38"	9.6	RH	WIL160-12291	\$107.98
12.19"	0.81"	8 x 7.00"	0.325"	8.34"	6.38"	9.6	LH	WIL160-12292	\$107.98
12.00"	0.81"	8 x 7.00"	0.325"	8.41"	6.38"	9.0	RH	WIL160-12287	\$137.42
12.00"	0.81"	8 x 7.00"	0.325"	8.41"	6.38"	9.0	LH	WIL160-12288	\$137.42
11.75"	0.81"	8 x 7.00"	0.325"	7.87"	6.38"	9.0	RH	WIL160-12285	\$107.98
11.75"	0.81"	8 x 7.00"	0.325"	7.87"	6.38"	9.0	LH	WIL160-12286	\$107.98



HD Curved Vane Rotor

All HD rotors are cast from premium grade, long grain carbon iron for long wear, high thermal stability and resistance to distortion. Thick wall pad sweep faces with directional cooling vanes provide superior heat absorption and dissipation qualities to prevent heat fade and realize long service life from the pads and rotors. All HD rotor faces are precision turned to less than .001" for flatness, parallelism, and run-out for smoother engagement and reduced vibration.

Dia.	Width	Bolt Circle	Hole Type	Far Side I.D.	Lug I.D.	Weight LBS	RH/LH	Part #	Price
12.19"	1.25"	8 x 7.62"	5/16-24	8.41"	6.90"	12.7	RH	WIL160-3872	\$124.94
12.19"	1.25"	8 x 7.62"	5/16-24	8.41"	6.90"	12.7	LH	WIL160-3873	\$124.94
12.19"	1.25"	8 x 7.00"	0.313"	8.41"	6.53"	12.7	RH	WIL160-11835	\$112.44
12.19"	1.25"	8 x 7.00"	0.313"	8.41"	6.53"	12.7	LH	WIL160-11836	\$112.44
11.75"	0.99"	8 x 7.00"	0.326	8.46"	6.38"	7.1	RH	WIL160-13980	\$107.98
11.75"	0.99"	8 x 7.00"	0.326	8.46"	6.38"	7.1	LH	WIL160-13981	\$107.98
11.75"	0.99"	8 x 7.00"	0.326	8.46"	6.38"	7.1	RH	WIL160-13978	\$71.87
11.75"	0.99"	8 x 7.00"	0.326	8.46"	6.38"	7.1	LH	WIL160-13979	\$71.87
11.75"	0.81"	8 x 7.00"	0.325"	7.87"	6.38"	8.5	RH	WIL160-12283	\$89.08
11.75"	0.81"	8 x 7.00"	0.325"	7.87"	6.38"	8.5	LH	WIL160-12284	\$89.08



UL Series Curved Vane Rotor

Ultra-Light ULHP-32 directional vane rotors provide an excellent balance of efficient cooling and lower rotating mass on hard braking dirt tracks or rear axle service on pavement cars. UL rotors are cast from premium grade, long grain carbon iron for long wear, high thermal stability, and resistance to distortion. ULHP-32 rotors offered the added performance and smoother operation of precision turned faces with less than .001" variation in flatness, parallelism, or run-out.

Dia.	Width	Bolt Circle	Hole Type	Far Side I.D.	Lug I.D.	Weight LBS	RH/LH	Part #	Price
12.19"	1.25"	8 x 7.62"	5/16-24	8.50"	7.13"	10.1	RH	WIL160-2900	\$68.11
12.19"	1.25"	8 x 7.62"	5/16-24	8.50"	7.13"	10.1	LH	WIL160-2901	\$68.11
12.19"	1.25"	8 x 7.00"	0.325"	8.50"	6.38"	10.5	RH	WIL160-2894	\$62.44
12.19"	1.25"	8 x 7.00"	0.325"	8.50"	6.38"	10.5	LH	WIL160-2895	\$62.44
11.75"	1.25"	8 x 7.00"	0.325"	8.34"	6.38"	9.6	RH	WIL160-2898	\$39.33
11.75"	1.25"	8 x 7.00"	0.325"	8.34"	6.38"	9.6	LH	WIL160-2899	\$39.33

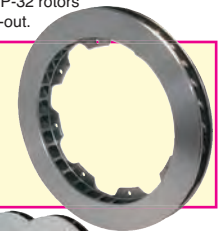

Super Alloy Scalloped Rotors

Our newest Super Alloy rotor in 11.75" diameter is targeted directly to Dirt Late Model and Modified racing. Wilwood's proprietary Super Alloy material provides the lowest rotating and un-sprung weight, without degradation, shrinkage and warping like comparable Iron & Steel lightweight rotors. Super Alloy rotors provide a durable lightweight option in applications where sustained temperatures remain in the low to moderate range, and high heat spikes are only observed on an intermittent basis. Our special alloy and proprietary manufacturing processes give these rotors high resistance to thermal distortion with excellent friction and wear characteristics against the pads.

Dia.	Width	Bolt Circle	Hole Type	Far Side I.D.	Lug I.D.	Weight LBS	RH/LH	Part #	Price
11.75"	0.81"	8 x 7.00"	0.326"	8.19"	6.38"	5.0	RH/LH	WIL160-13373	\$179.93
11.75"	1.25"	8 x 7.00"	0.326"	8.19"	6.38"	5.0	RH/LH	WIL160-12041	\$189.95



UL Series Straight Vein Rotors

When it comes to rotors, racers are constantly searching for the ultimate balance between the lowest weight & the ability to effectively manage heat. Lower weight also benefits handling with improved spring & shock control over the unsprung suspension mass. WIL ULHP-32 drilled iron rotors provides effective LW options for sprints, late models, modifieds, & other competition apps that race in low to medium temp ranges.

Dia.	Width	Bolt Circle	Hole Type	Far Side I.D.	Lug I.D.	Weight LBS	RH/LH	Part #	Price
12.19"	0.81"	8 x 7.00"	0.325"	8.50"	6.38"	8.0	RH/LH	WIL160-5865	\$62.44
11.75"	1.25"	8 x 7.00"	0.325"	8.34"	6.38"	7.7	RH/LH	WIL160-5864	\$44.98
11.75"	0.81"	8 x 7.00"	0.325"	8.34"	6.38"	7.2	RH/LH	WIL160-5863	\$62.44

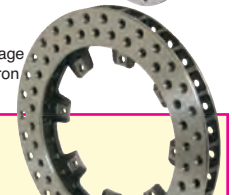

BER544



BER544-2



BER544-3

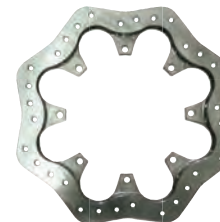

BER547-L

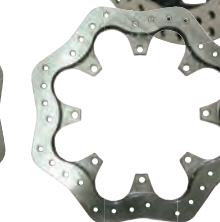

BER547-R

Wave Brake Rotor



3/8" x 12.00 (8 Holes)	BER544-2	\$93.86
3/8" x 12.19 (8 Holes)	BER544-3	\$93.86
3/8" x 12.00 (3 Holes)	BER544	\$96.92
.810" x 12.19 (8 Holes) Left	BER547-L	\$192.15
.810" x 12.19 (8 Holes) Right	BER547-R	\$192.15

Bert engineering is offering an interesting alternative to the times spent of safety wiring your rotor bolts. The answer is the nord-lock. This unique securing system used tension to make the bolt self locking from cold to hot and from hot to cold your rotor will not loosen.



Ultralite HPS 32 Vane Rotor

Ultra-Light ULHP straight vane rotors provide high value performance and rugged durability for a wide range of competition, high performance, and sport driving applications. Don't confuse these rotors with bargain priced off-brand name parts. Wilwood's modern manufacturing capability, combined with large scale economies, make it possible to offer this level of quality and performance at such an affordable price.

ULHP Series									
Dia.	Width	Bolt Circle	Hole Type	Far Side I.D.	Lug I.D.	Weight LBS	Rotor Type	Part #	Price
12.19"	1.10"	8 x 7.00"	0.325"	8.34"	6.38"	13.9	ULHP-32	WIL160-12206*	\$87.43
12.19"	0.81"	8 x 7.78"	0.251"	8.53"	7.29"	8.7	ULHP-32	WIL160-6984	\$93.68
12.19"	0.81"	8 x 7.78"	0.251"	8.53"	7.29"	8.7	ULHP-32	WIL160-9585*	\$99.93
12.19"	0.81"	8 x 7.62"	5/16-24	8.50"	7.13"	8.8	ULHP-32	WIL160-5844	\$73.24
12.19"	0.81"	8 x 7.00"	0.325"	8.50"	6.38"	8.9	ULHP-32	WIL160-5843	\$73.24
11.75"	0.81"	8 x 7.00"	0.325"	8.34"	6.38"	8.1	ULHP-32	WIL160-5841	\$73.24
11.00"	0.81"	6 x 6.25"	0.325"	7.00"	5.59"	7.9	ULHP-30	WIL160-5840	\$73.24
11.00"	0.81"	6 x 6.25"	0.325"	7.00"	5.59"	7.9	ULHP-30	WIL160-10358*	\$97.48
10.75"	0.81"	6 x 6.25"	0.325"	7.00"	5.59"	7.4	ULHP-30	WIL160-5839	\$73.24



UL Series									
Dia.	Width	Bolt Circle	Hole Type	Far Side I.D.	Lug I.D.	Weight LBS	Rotor Type	Part #	Price
12.19"	0.81"	8 x 7.00"	0.325"	8.50"	6.38"	8.9	UL-32	WIL160-0277	\$33.75
12.00"	1.20"	8 x 7.00"	0.325"	8.34"	6.38"	8.6	UL-32	WIL160-0586	\$49.72
11.75"	1.25"	8 x 7.00"	0.325"	8.34"	6.38"	8.8	UL-32	WIL160-0483	\$32.25
11.75"	0.81"	10 x 6.81"	0.325"	8.00"	6.28"	9.1	UL-30	WIL160-0790	\$80.94
11.75"	0.81"	8 x 7.00"	0.325"	8.34"	6.38"	8.1	UL-32	WIL160-0471	\$32.25
11.75"	0.75"	8 x 7.62"	5/16-24	8.50"	7.13"	6.9	UL-32	WIL160-1949	\$77.00
10.50"	0.75"	8 x 5.50"	0.325"	6.75"	4.94"	6.6	UL-30	WIL160-3450	\$62.43
10.25"	0.75"	8 x 5.50"	0.325"	6.75"	4.94"	6.1	UL-30	WIL160-3747	\$62.43

*These rotors have a unique asymmetrical face groove pattern.



Ultralite 32 Vane Scalloped Rotor

They feature a fully machined scallop configuration that provides the highest degree of weight reduction on a vented straight vane iron rotor. Scallop machining will remove as much as 3 lbs, or nearly 33% of the rotor mass. The vented castings provide increased cooling capacity over machined steel plate rotors, with improved structural durability over drilled rotor designs. It provides effective lightweight options for sprints, late models, modifieds, and other competition applications that race in low to medium temperature ranges.

Dia.	Width	Bolt Circle	Hole Type	Far Side I.D.	Lug I.D.	Weight LBS	RH/LH	Part #	Price
12.19"	0.81"	8 x 7.00"	0.325"	8.50"	6.38"	5.9	RH/LH	WIL160-8136	\$80.94
11.75"	1.25"	8 x 7.00"	0.325"	8.34"	6.38"	5.8	RH/LH	WIL160-8343	\$80.94
11.75"	1.25"	8 x 7.00"	0.325"	8.75"	6.38"	6.7	RH/LH	WIL160-8814	\$80.94
11.75"	0.81"	8 x 7.00"	0.325"	8.34"	6.38"	5.4	RH/LH	WIL160-8135	\$80.94
10.50"	0.75"	6 x 5.50"	0.325"	7.30"	4.94"	3.8	RH/LH	WIL160-8427	\$87.43

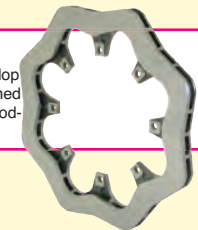

Titanium Super Alloy Scalloped Rotor

Super Alloy and Titanium 10.50" x .810" Vented Rotors are one of Sprint racing's lightest .810" rotor at a weight of only 2.40 to 3.20 pounds. Proprietary Super Alloy Titanium or Steel greatly enhances the durability and lifespan of this rotor over comparable lightweight steel or aluminum rotors. A Drilled, slotted, and scalloped design with 24 cooling vanes provides excellent high temperature stability, rapid heat dissipation, and consistent performance from the brake pads. The fine micro-finish surface beds quickly with new pads. It provides a cost effective, lightweight solution with quick response, long service life from the pads, and consistent braking at all temperatures. Lowered rotating weight promotes quick acceleration, deceleration, and improved handling.

Dia.	Width	Bolt Circle	Hole Type	Far Side I.D.	Lug I.D.	LBS	Rotor Type	Part #	Price
10.50"	0.81"	6 x 5.50"	0.325"	7.03"	4.94"	2.9	ULS-24 Super Alloy	WIL160-11217	\$179.93
10.50"	0.16"	9 x 7.00"	0.266"	7.49"	6.25"	1.1	Scalloped Super Alloy	WIL160-10717	\$143.74
12.00"	0.36"	8 x 7.00"	0.320"	N/A	6.36"	3.3	Titanium	WIL160-12571	\$729.60



SRP Drilled and Slotted for Street Application Performance Rotor

SRP Drilled Performance Rotors feature a specially engineered directional cross drill and face slot pattern that improve brake response and pad performance throughout the entire range of light to heavy braking. The venting and cleaning action of the holes and slots will reduce pad glaze and disperse gasses and heat generated during the pad to rotor interface. The holes and slots also inhibit irregular pad compound build-up on the rotor faces resulting in smoother engagement and improved pedal response in all conditions. The material removed also contributes to lower rotating and unsprung suspension weight.

Dia.	Width	Bolt Circle	Hole Type	Far Side I.D.	Lug I.D.	Weight LBS	RH/LH	Part #	Price
12.19"	1.10"	8 x 7.00"	0.325"	8.34"	6.38"	13.4	RH	WIL160-12204-BK	\$137.42
12.19"	1.10"	8 x 7.00"	0.325"	8.34"	6.38"	13.4	LH	WIL160-12205-BK	\$137.42
12.19"	0.81"	8 x 7.78"	0.251"	8.53"	7.29"	8.6	RH	WIL160-6924-BK	\$130.94
12.19"	0.81"	8 x 7.78"	0.251"	8.53"	7.29"	8.6	LH	WIL160-6925-BK	\$130.94
12.19"	0.81"	8 x 7.62"	5/16-24	8.50"	7.13"	8.6	RH	WIL160-7105-BK	\$123.24
12.19"	0.81"	8 x 7.62"	5/16-24	8.50"	7.13"	8.6	LH	WIL160-7106-BK	\$123.24
12.19"	0.81"	8 x 7.00"	0.325"	8.50"	6.38"	8.8	RH	WIL160-7103-BK	\$123.24
12.19"	0.81"	8 x 7.00"	0.325"	8.50"	6.38"	8.8	LH	WIL160-7104-BK	\$123.24
12.00"	0.81"	8 x 7.00"	0.325"	8.41"	6.38"	8.3	RH	WIL160-8496-BK	\$166.93
12.00"	0.81"	8 x 7.00"	0.325"	8.41"	6.38"	8.3	LH	WIL160-8497-BK	\$166.93
11.75"	1.25"	5 x 4.75"	---	7.06"	---	19.0	RH	WIL160-11285-BK	\$107.43
11.75"	1.25"	5 x 4.75"	---	7.06"	---	19.0	LH	WIL160-11286-BK	\$107.43
11.75"	1.25"	5 x 4.75"	---	7.06"	---	17.2	RH	WIL160-11287-BK	\$107.43
11.75"	1.25"	5 x 4.75"	---	7.06"	---	17.2	LH	WIL160-11288-BK	\$107.43
11.75"	0.81"	8 x 7.00"	0.325"	8.34"	6.38"	8.0	RH	WIL160-7101-BK	\$123.24
11.75"	0.81"	8 x 7.00"	0.325"	8.34"	6.38"	8.0	LH	WIL160-7102-BK	\$123.24

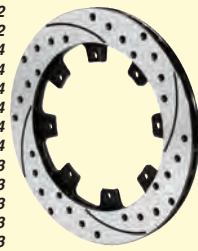

Drilled Steel Dynamic Mount Rotor

Steel rotors have applications in all types of motorsports. Steel rotors provide a durable lightweight option in applications where sustained temperatures remain in the low to moderate range, and high heat spikes are only observed on an intermittent basis. This could be anything from a hard stopping drag race car at the end of a quarter mile, or a high speed stock car coming in from a qualifier at a super speedway. Steel rotors can also be found in lighter weight open wheel cars such as sprints and modifieds, and a variety of light weight, open wheel road course racers. A special alloy and proprietary manufacturing processes give these rotors high resistance to thermal distortion with excellent friction and wear characteristics against the pads.

Dia.	Width	Bolt Circle	Hole Type	Lug I.D.	Bolt Kit	LBS	Rotor Type	Part #	Price
12.90"	0.38"	12 x 8.75"	SLOT	8.25"	WIL230-4900	5.7	SSP	WIL160-4766	\$193.67
12.19"	0.35"	8 x 7.00"	0.325	6.38"	(1, 2)	4.5	SCALLOP (Direct Mount)	WIL160-9773	\$74.98
12.19"	0.35"	8 x 7.00"	SLOT	6.56"	(1, 2)	4.8	SCALLOP	WIL160-5538	\$137.42
11.75"	0.35"	8 x 7.00"	0.325	6.38"	(1, 2)	4.1	SCALLOP (Direct Mount)	WIL160-9772	\$74.98
11.75"	0.35"	8 x 7.00"	SLOT	6.56"	(1, 2)	4.5	SCALLOP	WIL160-5855	\$137.42

- (1) To mount this rotor on a 5/16-18 threaded hat or hub, use bolt and t-nut kit WIL230-5308.
- (2) To mount this rotor on a sprint car or open wheel acle mount clamp, use bolt kit and t-nut kit WIL230-5567.

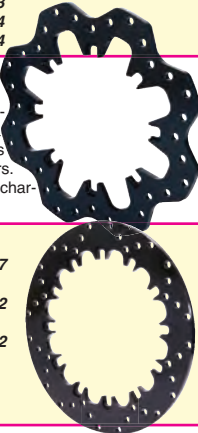

Standard Mount Steel Rotors

Steel rotors have applications in all types of motorsports. Steel rotors provide a durable lightweight option in applications where sustained temperatures remain in the low to moderate range, and high heat spikes are only observed on an intermittent basis. This could be anything from a hard stopping drag race car at the end of a quarter mile, or a high speed stock car coming in from a qualifier at a super speedway. Steel rotors can also be found in lighter weight open wheel cars such as sprints and modifieds, and a variety of light weight, open wheel road course racers. A special alloy and proprietary manufacturing processes give these rotors high resistance to thermal distortion with excellent friction and wear characteristics against the pads.

6 and 8 Bolt

Dia.	Width	Bolt Circle	Hole Type	Lug I.D.	Weight LBS	Rotor Type	Part #	Price
12.00"	0.31"	8 x 7.62"	5/16-24	7.00"	4.6	DRILLED	WIL160-0495	\$94.93
12.00"	0.35"	8 x 7.00"	0.325"	6.38"	5.4	DRILLED	WIL160-0525	\$94.93
11.75"	0.35"	8 x 7.00"	0.325"	6.38"	5.9	SOLID	WIL160-3201	\$81.00
11.75"	0.35"	8 x 7.00"	0.325"	6.38"	5.3	DRILLED	WIL160-3202	\$94.93
11.44"	0.35"	8 x 7.00"	0.325"	6.38"	5.4	SOLID	WIL160-0201	\$71.94
11.44"	0.35"	8 x 7.00"	0.325"	6.38"	4.7	DRILLED	WIL160-1601	\$94.93
10.75"	0.35"	6 x 6.25"	0.316"	5.54"	5.2	SOLID	WIL160-3305	\$71.94
10.75"	0.35"	6 x 6.25"	0.316"	5.54"	4.7	DRILLED	WIL160-3306	\$94.93
10.50"	0.35"	6 x 5.50"	0.325"	4.94"	4.7	DRILLED	WIL160-3455	\$94.93
10.25"	0.35"	6 x 5.50"	0.325"	4.94"	4.6	DRILLED	WIL160-3748	\$119.48



3 and 5 Bolt

Dia.	Width	Bolt Circle	Hole Type	Lug I.D.	Weight LBS	Rotor Type	Part #	Price
11.00"	0.31"	3 x 5.00"	0.500"	4.10"	4.6	DRILLED	WIL160-2084	\$94.93
11.00"	0.31"	3 x 5.00"	0.500"	4.10"	3.3	DRILLED	WIL160-10475	\$74.98
10.25"	0.31"	3 x 5.00"	0.500"	4.10"	4.1	DRILLED	WIL160-3458	\$105.49
10.00"	0.32"	5 x 3.88"	0.391"	3.12"	4.8	DRILLED	WIL160-2182	\$94.93
10.00"	0.25"	5 x 5.00"	0.391"	4.10"	3.2	DRILLED	WIL160-1602	\$94.93



OEM or Street Stock Replacement Racing Rotor

Wilwood's GM OEM Replacement Racing Rotors for Modifieds: These rotors were designed utilizing the latest developments in iron formulation technology using our proprietary blend ferrous alloy to bring you the strongest, lightweight, most dependable rotor available in the market place. The rotors are new castings, not reworked parts and our tolerances are held to the high standards you have come to expect from Wilwood Engineering. Rotors are offered in two configurations - GM Metric and Ford Hybrid and come standard with races and 5/8" coarse wheel studs installed in the 5 on 5 bolt pattern. The GM Metric rotor is 10.50" diameter by 1.00" thick and fits the 1979-1988 GM spindles. The Ford Hybrid version is 10.15" diameter by .810" thick rotor that fits the 1974-1980 Pinto spindles.



Dia.	Width	Bolt Circle	Stud Dia.	Installation Kit	Weight LBS	Rotor App	Part #	Price
10.50"	1.00"	5 x 5.00"	0.625"	WIL370-9537	14.9	GM Metric	WIL160-9239	\$53.54
10.15"	0.81"	5 x 5.00"	0.625"	WIL370-9545	14.5	Ford Hybrid	WIL160-9240	\$53.54

Aluminum Sprint / Midget Rotor-42T

Wilwoods 3.00" x 42 spined axle mount rotors are manufactured from the same high strength billets with the same precision as our 3 hole mount front rotors. Full symmetrical machining provides perfect balance, perfect flatness and the truest rotation of any aluminum rotor being built. Wilwoods engineered drill pattern combines the highest degree of weight reduction with the highest resistance to thermal distortion in the contact faces. You get smooth engagement and a consistent full pedal from the low knock-back characteristics of this design. A durable black anodized finish prevents corrosion and simplifies the visual inspection of the contact faces. The best results are always achieved using PolyMatrix Q compound brake pads with these rotors.

3 Hole Mount

Dia.	Width	Bolt Circle	Hole Type	Weight LBS	Rotor Type	Part #	Price
10.95"	0.31"	3 x 5.00"	0.516"	1.8	DRILLED	WIL160-3327	\$56.24
10.20"	0.31"	3 x 5.00"	0.516"	1.6	DRILLED	WIL160-3411	\$56.24

Spined Axle Mount

Dia.	Width	Bolt Circle	Hole Type	Weight LBS	Rotor Type	Part #	Price
10.95"	0.31"	3 x 42 Spline		2.3	DRILLED	WIL160-3275	\$49.90
10.20"	0.31"	3 x 42 Spline		1.9	DRILLED	WIL160-3270	\$62.44

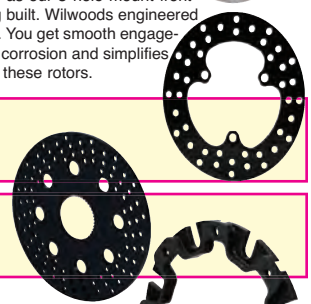

Zero Offset Rotor Adapter for Wide 5 Hubs

Wilwood's new Zero Offset Rotor Adapter for Wide 5 hubs adapts any standard fixed mount rotor hub with an 8 x 7.00" bolt circle, to a dynamic rotor mount. Adapter is supplied with a standard 8 x 7.00" pattern for hub mounting and an 8 x 7.00" dynamic pattern for rotor mounting. Made from high strength aluminum alloy and hard anodized for wear resistance. Use Dynamic mount bolt kit part # 230-10483 and Adapter to hub bolt kit 230-8390.

Zero Offset Rotor Adapter for Wide 5 Hub	WIL300-14294	\$98.94
Dynamic Mount Bolt Kit, 12PT	WIL230-10483	\$44.98
Dynamic Mount Bolt Kit, SHCS	WIL230-8454	\$44.98
Adapter to Hub Bolt Kit	WIL230-8390	\$13.69



Dynamic Mount Rotor Plates for Wide 5 Hubs

These plates attach directly to the rotor mount bosses on wide 5 hubs & use the T-Nut rotor bolt kits to "float" mount any std 5/16" hole rotor with an 8 on 7" bolt circle. Use of these plates requires hubs that have been specially machined to compensate for the plate thickness to maintain the original rotor position.

Rotor Bolt Circle	Hub Mounting Bolt Pattern	Plate Offset	Hub Mount Hole I.D.	Plate Lug I.D.	Plate O.D.	Plate Thickness	Rotor Mount	Plate Part #	WIL300-8431	Price
8 x 7.00"	8 x 7.00"	0"	.32"	5.50"	7.60"	.24"	T-SLOT	Bolt & T-Nut SHCS	WIL230-8454	\$62.43
								Bolt & T-Nut 12PT	WIL230-10483	\$44.98

Fixed Mount Rotor Mounting Hats

It has a long standing reputation for fit, performance, and durability. HD Series hats are manufactured from premium grade aluminum alloys offering high strength, low weight, and show quality appeal. HD hats have not only been a mainstay in many of Wilwood's brake conversion kits, but they can cover a range of applications from an OE four lug axle shaft to a Grand National stock car racing hub. HD hats feature a straight bell construction with a flanged rotor mounting ring. These features combine to provide maximum radial clearance between the caliper body and the hat. This can be a critical factor when trying to squeeze a large caliper inside a small wheel. Many hats offer multi-lug wheel patterns for added versatility. Some hats can be ordered blank for custom axle building & other unique apps.

HD Fixed Mount Aluminum Hats for 5/16-24 Threaded Hole Rotors

Rotor Bolt Circle	Wheel Lug Pattern	Hat Offset	Stud Hole Diameter	Center Hole I.D.	Face Thickness	Clearance I.D.	Mount Hole	Hat Part #	Rotor Bolt Kit #	Price
8 x 7.62"	6 x 5.00"	2.00"	0.64"	3.50"	0.25"	6.50"	0.323"	WIL170-0089	WIL230-0150	\$92.44 / \$11.19

HD Fixed Mount Aluminum Hats for 5/16 Through Hole Rotors

Rotor Bolt Circle	Wheel Lug Pattern	Hat Offset	Stud Hole Diameter	Center Hole I.D.	Face Thickness	Clearance I.D.	Mount Hole	Hat Part #	Rotor Bolt Kit #	Price
8 x 7.00"	5 x 4.50/4.75/5.00"	1.96"	0.52"	3.06"	0.25"	6.14"	5/16-18	WIL170-0208	WIL230-0233D	\$78.69 / \$8.95
8 x 7.00"	5 x 4.50/4.75/5.00"	1.59"	0.52"	3.06"	0.25"	6.14"	5/16-18	WIL170-0317	WIL230-0233D	\$78.69 / \$8.95

wilwood

Starlite "55" Wide 5 Racing Hubs

It kit provides a basis to bolt dynamic rotor rotor mounting of standard 8 x 7.00" bolt pattern rotors. Contains rotor adapter and dynamic rotor mounting bolt kit. Made from high strength aluminum. It provides a LW and strong solution for rotor mounting.



Rear 5 Bolt Drive

Offset	Finish	Studs	Part #	Price
Standard	Aluminum	.5/8" Coarse	WIL270-6513C	\$115.55
Standard	Aluminum	.5/8" Coarse Drilled	WIL270-6513D	\$121.80
Standard	Black	.5/8" Coarse	WIL270-6513BC	\$128.67
Standard	Black	.5/8" Coarse Drilled	WIL270-6513BD	\$134.92

Front w/Snap Cap

Offset	Finish	Studs	Part #	Price
Standard	Aluminum	.5/8" Coarse	WIL270-6735C	\$128.05
Standard	Aluminum	.5/8" Coarse Drilled	WIL270-6735D	\$134.30
Standard	Black	.5/8" Coarse	WIL270-6735BC	\$140.20
Standard	Black	.5/8" Coarse Drilled	WIL270-6735BD	\$147.42



Wide 5 Hubs Starlite 55XD

Starlite 55-XD hubs elevate performance and versatility for racing applications that require uncompromised strength without excessive additional weight. At just over 7 pounds, the 55-XD achieves its superior strength and modest weight through a highly efficient redesign of racing's most popular wide 5 hub, the Starlight 55. The 55-XD employs a bolt-on rotor mount plate that adds overall strength by eliminating the brake torque loading from the main hub body, by taking the stress loads of the braking torque out of the hub body and moving it to the thicker, stronger section of the hub near the inner wheel bearing, provides a measurable decrease in stress deflection in the body.

FrontWIL270-12127C\$193.68
RearWIL270-12111C\$187.43



Wide 5 Hub Parts and Accessories

Starlite "55" Drive Flanges/Hub Caps Ordering Information

Drive Flange Bolts with Washers - 5 PackWIL230-6911\$13.66
Std Five Bolt Drive Flange with Bolts, WashersWIL270-6732\$64.37
LW Five Bolt Drive Flange with Bolts, WashersWIL270-6733\$66.87
Snap Cap Front Hub Dust CoverWIL270-6913\$14.35
Five Bolt LW Steel Front Hub Cap, Gold Cad PlatedWIL270-9498\$8.05
Drive Flange Bolts with Washers - 5 PackWIL230-6911\$13.66
O-Ring, Snap CapWIL211-6950\$0.61

Starlite Drive Flanges/Hub Caps Ordering Information

Eight Bolt LW Steel Front Hub Cap, Gold Cad PlatedWIL270-0374\$8.69
Drive Flange/Hub Cap Bolt Kit - 8 PackWIL230-1378\$20.65

Bolt Kit (5-Bolt Drive Flange)

Stop buying 8-bolt kits for your 5-bolt flanges like above. 7/16" 14 bolts come w/12 heads predrilled for safety wire.

WIL230-6911\$13.66
-------------	--------------



AP Racing PRF Racing Brake Fluid

Developed for extreme, high temp racing conditions (dry boiling point of 608° F). Exceeds DOT 4 spec. Sold in 16.9 oz. bottle.

ALL78116\$29.99
----------	--------------

AP 600 Hi-Temp Racing Brake Fluid

Designed for extreme, high temp racing conditions with a dry boiling point in excess of 572 degs Fahrenheit. Exceeds DOT 3 stds. 1 pint container.

ALL78108\$23.99
----------	--------------

Castrol SRF Brake Fluid

Castrol SRF brake fluid has a wet boiling point of 518 deg. F (270 deg. C) which exceeds DOT 3 and 4 stds. Do not mix Castrol SRF and other brake fluids, as this will reduce the benefits of Castrol SRF. Sold in 1 liter containers (33.8 ozs.)

ALL78115\$79.99
----------	--------------



Self Bleed Check Valve

Wilwood Check Valves, or Flow Control Valves are used in conjunction with our caliper Self Bleed Lines. Together they form a closed loop brake fluid system that allows small amounts of brake fluid to circulate every time the brake pedal is depressed, thereby eliminating the possibility of localized fluid boiling and build-up of gases within the brake fluid. Gases end up being vented back into the master cylinder reservoir rather than trapped within the caliper and brake lines. Our Check Valve accepts standard 1/8-27 NPT fittings. For plumbing instructions request Wilwood's Data Sheet, DS-213.

Check Valve (flow control valve)WIL260-3501\$57.44
----------------------------------	-----------------	--------------



Residual Pressure Valve

Wilwood ten pound residual pressure valves retain a minimum brake line pressure to help eliminate excessive pedal travel in drum brake systems. With drum brakes, a ten pound valve is used to compensate for return spring tension and maintain wheel cylinder sealing in the drums. Residual Pressure Valves are made from billet aluminum and color coded for easy identification.

10 lbsWIL260-13707\$16.15
--------	-------------------	--------------



Residual Pressure Valve

Wilwood 2 pound residual pressure valves retain a minimum brake line pressure to help eliminate excessive pedal travel in both disc and drum brake systems. The two pound valve is used in disc brake applications where the master cylinder is mounted below the horizontal plane of the calipers and fluid drain back occurs from gravity and vibration, thereby causing excessive caliper piston retraction and a longer brake pedal stroke. The minimal two pound residual pressure prevents fluid from flowing back without causing the brakes to drag. With drum brakes, a ten pound valve is used to compensate for return spring tension and maintain wheel cylinder sealing in the drums. Residual Pressure Valves are made from billet aluminum and color coded for easy identification. Valves with fittings are supplied with two 1/8-27 NPT to 3/24 inverted flare female fittings that will most domestic 3/16th hard brake line.

2 lbsWIL260-13706\$16.15
-------	-------------------	--------------



Brake Bias Cable

It is used with balance bars to adjust front-to-rear brake bias during changing race conditions. The five foot cable and housing provides an optimum bending radius for easy installation and smooth performance in tight confines. The assembly comes with two label faces for either front-to-rear or rear-to-front adjustment.

WIL340-4990\$42.75
-------------	--------------



TCI Roll Stop

Pump the brake and hold, push the Roll Stop button, release the brake and the front wheels are locked. Now you can burnout like the pros. If you don't have enough pressure on the front brakes just pump again. The one way valve lets you add pressure once the button is depressed. Includes all hardware.

TCI861700\$99.14
-----------	--------------

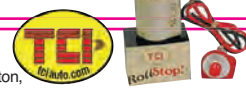

570 Hi-Temp Brake Fluid

PintWIL290-0632\$9.96
Case of 24WIL290-0633\$142.95

Super Hi-Temp EXP600 Plus Brake Fluid

PintWIL290-6209\$18.75
Case of 20WIL290-6210\$329.69



Anti-Roll Kit

Kit contains a heavy duty push button switch, switch bkt, coiled wire, rebuildable line-lock valve, fuse holder & indicator light. Continuous use of solenoid for 30+ seconds will damage the coil.

MOR44050\$122.61
----------	---------------



Brake Ducts

Durable plastic brake ducts direct outside air for cooling brakes, oil coolers even the driver, and are available in centered, offset and dual outlet configurations.

Clear TeardropALL42143\$22.99
----------------	--------------	--------------



Brake Duct Hose

Hose is designed to direct air from front mounted air ducts to spindle ducts for brake cooling. Flexible, non kinking hose is available in 3 temp ranges. Sold in 10 ft. lengths. 275° -3" single ply thermoplastic rubber wall with a spring steel wire support. 300° - 3" or 4" double ply neoprene coated woven fiberglass hose with a spring steel wire inner and an external fiberglass cord support. Smooth inner wall for unrestricted flow. 550° -3" or 4" double ply silicon coated woven fiberglass hose with a spring steel wire inner and an external fiberglass cord support. Smooth inner wall for unrestricted flow. Brake Duct Hose, 3" x 10', Black, 300 degrees

ALL42151\$55.99
----------	--------------





Dynapro Radial Sprint Inboard Brake Kit

Features: A fully engineered bolt-on brake sys. for sprint car quick change rears with 3.00 x 46 splined axles. With titanium or Super Alloy .810 vented discs and a newly designed dynamic mt rotor axle clamp, are the lowest rotating weights available for Sprint racing. The lw advantages of the titanium rotor are fortified with the high durability, long wear, and superior heat control properties of advanced PolyMetallic coating tech. Forged billet DynaPro radial mt calipers with Composition Metallic pads, produce superior stopping power and consistent fade-free response. Kit includes Axle Clamp with Dynamic Mt Rotor Adapter assembly with T-nuts and Radial Mount Bracket and mounting hardware.



WIL140-11762.....\$1,004.46

Billet Narrow Dynapro Radial Sprint Rear Inboard Kits

Features: A fully engineered bolt-on brake system for sprint car quick change rears with 3.00 x 46 splined axles. With Super Alloy Titanium 12.00" x .36" disc and a newly designed dynamic mt rotor axle clamp, are the lowest rotating weights available for Sprint racing. The lw advantages of the steel rotor mean a lower cost. Forged billet DynaPro radial mt calipers with Composition Metallic pads, produce superior stopping power and consistent fade-free response. Kit includes Axle Clamp with Dynamic Mt Rotor Adapter assembly with T-nuts and Radial Mt Bkt and mounting hardware.



WIL140-12764.....\$1163.95

Dynapro Radial Sprint Inboard Brake Kit

Features: A fully engineered bolt-on brake system for sprint car quick change rears with 3.00 x 46 splined axles. With Super Alloy.810 vented discs and a newly designed dynamic mount rotor axle clamp, are the lowest rotating weights available for Sprint racing. • The lightweight advantages of the Super Alloy rotor are combined with high durability & long wear. • Forged billet DynaPro radial mount calipers with Composition Metallic pads, produce superior stopping power and consistent fade-free response. Kit includes Axle Clamp with Dynamic Mount Rotor Adapter assembly with T-nuts and Radial Mount Bracket and mounting hardware.

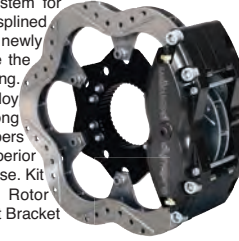

WIL140-11206.....\$624.57

Dynapro Radial Sprint Inboard Brake Kit

Features: A fully engineered bolt-on brake system for sprint car quick change rears with 3.00 x 46 splined axles. With Steel Scalloped 11.75" x .35" disc and a newly designed dynamic mount rotor axle clamp, are the lowest rotating weights available for Sprint racing. • The lightweight advantages of the steel rotor mean a lower cost. • Forged billet DynaPro radial mount calipers with Composition Metallic pads, produce superior stopping power and consistent fade-free response. Kit includes Axle Clamp with Dynamic Mount Rotor Adapter assembly with T-nuts and Radial Mount Bracket and mounting hardware.



WIL140-11323.....\$510.57

GP320 Sprint Left Front Brake Kit

It offers increased braking torque and thermal performance of the GP320 4 piston calipers. A definitive increase in braking and durability over traditional aluminum or steel rotor systems. Mounts are included for standard Sprint spindle to match the included 10.50 x 0.19" Super Alloy rotor. Also includes Composition Metallic brake pads, lightweight aluminum dynamic mount 3-pin rotor adapter and T-nut hardware kit.



WIL140-11773.....\$449.09

GP320 Sprint Right Rear Brake Kit

It offers increased braking torque and thermal performance of the GP320 4 piston calipers. A definitive increase in braking and durability over traditional aluminum rotor systems. Kit includes 10.50 x 0.19" Super Alloy steel rotor, Composition Metallic brake pads, lightweight aluminum dynamic mount 3-pin rotor adapter and T-nut hardware kit.

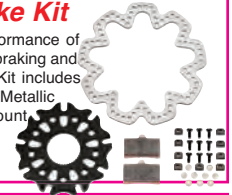

WIL140-11774.....\$449.09

Narrow Dynapro Lug Mount Sprint Inboard Brake Kit

Wilwood's Narrow Dynapro Lug Mount Sprint Inboard Kit Features: A fully engineered bolt-on brake system for sprint car quick change rears with 3.00 x 46 splined axles. With an economical 12.19 x .810 diameter cast iron vented rotor and a newly designed dynamic mount rotor axle clamp. Forged billet DynaPro lug mount calipers with PolyMatrix B compound pads, produce superior stopping power and consistent fade-free response. Kit includes Axle Clamp with Dynamic Mount Rotor Adapter assembly with T-nuts.



WIL140-11507.....\$510.57

Sprint - Open Wheel Live Axle Clamp-on Rotor Mount

Wilwood's Sprint inboard hub and adapter kit provides a basis to bolt dynamic rotor rotor mounting of standard 8 x 7.00" bolt pattern rotors. Contains rotor adapter and dynamic rotor mounting bolt kit. Made from high strength aluminum. It provides a lightweight and strong solution for rotor mounting.

- Sprint, Inboard, Splined, 4" ODGEN II w/Rotor Adapter, 8 x 7.00WIL270-12633.....\$182.43
- Midget, Inboard, Splined, 4" ODGEN II w/Rotor Adapter, 6 x 5.50WIL270-12634.....\$182.43
- Sprint, Inboard, Splined, 4" ODGEN II w/Rotor Adapter, 6 x 5.50WIL270-12635.....\$182.43

Sprint/Midget Rotor Adapter

Rotor adapter for Sprint / Midget front hubs. Adapter is supplied with a standard 3 x 5.00" pattern for hub mounting and a dual 8 x 7.00" dynamic or fixed bolt pattern for rotor mounting. Made from high strength aluminum alloy and hard anodized for wear resistance.

- Rotor Adaptor Floating/Fixed - Sprint/Modified Hub 8 x 7.00 BC 3 x 5.00 BC ...WIL300-13474\$44.93
- Rotor Bolt Kit - Dynamic Rear 8 Bolt with T-NutsWIL230-5308\$44.98



Dynamic Mount Bolt Kits for through Hole Rotors with T-Slotted Hats or Plates

Bolt kits in this group include bolts, t-nuts, and associated hardware to attach a standard through-hole mount rotor to a dynamic mount, t-slot machined hat or rotor plate. All bolts are lock-wire drilled.

Qty	Bolt Size	Bolt Type	Applications	Part #	Price
12	1/4-28 x 0.75"	Stainless Steel 12 Point	GT Hats	WIL230-6656	\$74.93
8	1/4-28 x 0.75"	Stainless Steel 12 Point	GT Hats	WIL230-6709	\$44.98
8	5/16-24 x 0.81"	Stainless Steel 12 Point	GT Hats, 5 x 5 Hub Plate	WIL230-6710	\$49.99
8	5/16-24 x 0.75"	Grade 8 Socket Head	Wide 5 Hub Plate	WIL230-8454	\$44.98



Dynamic Mount Bolt Kits for Slotted Hole Steel Rotors

These bolt kits include bolts, t-nuts, and associated hardware to attach a specially machined slotted hole plate steel rotor to a threaded hat, hub, or live axle rotor clamp. All kits are supplied with either lock-wire drilled bolts or crimp nuts.

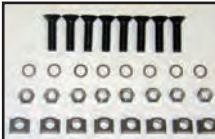

Qty	Bolt Size	Bolt Type	Applications
8.00"	5/16-24 x 1.25"	Grade 8 Countersunk	Live Axle Rotor Clamp
WIL230-5567			\$44.98
8.00"	5/16-24 x 0.81"	Grade 8 Socket Head	Threaded Hats, Wide 5 Hubs
WIL230-5308			\$44.98

Bolt Kits for Fixed Mount Threaded or Through Hole Mt Rotors

Bolt kits also come with any other necessary hardware to attach a threaded or through hole mount rotor or rotor mounting plate to a threaded or through hole mount hat, hub, or live axle rotor clamp. With one exception, all bolts are lock wire drilled.



Qty	Bolt Size	Bolt Type	Applications
8.00"	5/16-24 x 0.75"	Grade 8 Socket Head	Threaded Rotors on Through Hole Hats
WIL230-0150			\$11.19
8.00"	5/16-18 x 1.00"	Grade 8 Hex Head	Wide 5 Hubs, Threaded Hats
WIL230-0526			\$5.35
8.00"	5/16-18 x 0.75"	Grade 8 Short Profile Hex	Drag Race Rear Axle Kits
WIL230-0233D			\$8.95

PEDAL ASSEMBLY



Reverse Facing Single Pedal Assemblies

(Master Cylinder Not Included)

With balance bar for dual master brake systems. Reverse facing masters. Both are swing mount type.

- 10" pedal (5.1:1 ratio).....WIL340-13837
- 11.7" pedal (6.25:1 ratio)...WIL340-12509..\$147.43



Forward Facing Single Pedal Assemblies

(Master Cylinder Not Included)

Complete with balance bar for dual master brake systems.

- 10" pedal (6:1 ratio) - Floor Mount WIL340-13831\$116.95
- 12" pedal (7:1 ratio) - Swing Mount WIL340-13832\$116.95



Reverse Swing Mount Triple Master Cylinder Clutch and Brake Pedal

w/Balance Bar (Master Cylinder Not Included)

This assembly combines the brake and clutch pedals together in 1 unit & positions the master cylinder inside the firewall & away from the engine heat.

- Triple Mt Clutch & Brake Pedal w/Balance Bar (5.1:1 ratio).....WIL340-13835 .**\$203.33**
- (6.25:1 ratio)...WIL340-11295 .**\$203.33**

- 6.25:1 Brake / 5.1:1 Clutch WIL340-13836 .**\$203.33**



Adjustable Forward Swing Mount Triple Master Cylinder Pedal - Aluminum

It features all alum frame and forged aluminum pedal arms with ladder style construction. Pedal pads are of special adjustable design that allows fine-tuning of the pedal location and clearance. Also included with the assembly: mounting studs, hardware, new clevis and pivot pin balance bar assembly to provide smooth and accurate settings of the brake pedal bias. The balance bar can be set and locked down with the jam nut, or attached to a remote cable for quick on-track adjustments. With a 6.25 to 1 pedal ratio on both clutch and brake pedals.

- Forward.....WIL340-11295...\$203.33
- Reverse.....WIL340-11299...\$203.33

WIL340-11299

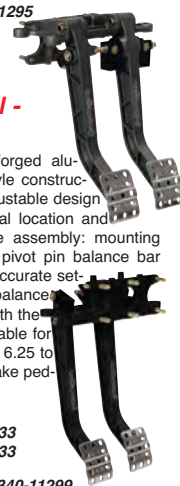

Clutch Pedal Assemblies

(Master Cylinder Not Included)

For clutch pedal or single master cylinder brake applications.

- 10" pedal (6:1 ratio) - Floor Mount WIL340-13833\$69.18
- 12" pedal (7:1 ratio) - Swing Mount WIL340-13834\$69.18



Adjustable Pedal Retrofit Kit

These retrofit kits will upgrade your existing forward (near right photo) or reserve (far right photo) swing mount triple master cylinder pedal assemblies to our new adjustable style without having to replace the complete pedal assembly. Installation is quick and simple.

- Adjustable Forward Mount Triple Master Cylinder Pedal Retrofit Kit 6.25:1 WIL340-12043**\$107.43**

- Adjustable Reverse Mount Triple Master Cylinder Pedal Retrofit Kit 6.25:1 WIL340-12044**\$99.93**

Tru-Bar Balance Bar Brake Pedal Assembly

It utilizes a fixed trunnion bearing in the pedal arm with spherical rod ends at the pushrod connections. It provides the ultimate in precision bias adjustment, control and fine tuning on race prepped vehicles equipped with twin brake master cylinder systems and proportionately sized calipers. Pedal shown with optional master cylinders.

Dual Master Cylinder

- Reverse Swing Mt, 5.1:1 Ratio Brake WIL340-15076 .**\$304.06**
- Reverse Swing Mt, 6.25:1 Ratio Brake WIL340-15077 .**\$304.06**
- Forward Mt, 6:1 Ratio Brake WIL340-15078 .**\$273.56**
- Forward Swing Mt, 7:1 Ratio Brake WIL340-15079 .**\$273.56**

Triple Master Cylinder

- Forward Swing Mount 6.25:1 Ratio, Brake & Clutch WIL340-15072 .**\$359.95**

Reverse Swing Mount

- 5.1:1 Ratio, Brake & Clutch WIL340-15073 .**\$359.95**
- 6.25:1 Ratio, Brake & Clutch WIL340-15074 .**\$359.95**
- 6.25:1 Ratio, Brake & 5.1:1 Ratio Clutch WIL340-15075 .**\$359.95**

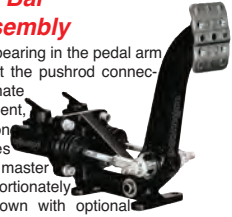

Balance Bar Replacement

It is designed to max travel and adjustability providing increased front-to-rear bias control. The precision spherical bearing with corrosion resistant finish is durable and smooth performing. The 3/8-24 threaded adjuster bar is high strength aircraft alloy and fitted with LW, maintenance free clevises and thrust washers to eliminate binding under extreme pivot angles. Includes steel sleeve for easy weld on operation to fabricated steel pedal assemblies.

- With Sleeve.....WIL340-1757 ..**\$54.93**
- Without Sleeve....WIL340-4745...**\$48.15**



Clutch Slave Cylinder

This "Pull Type" slave cylinder is made from billet aluminum for high strength and plated with a tough anti-corrosion finish. The stainless steel push rod has a longer stroke than most cylinders assuring a full release of the clutch. Ideal for Drag Racing, Late Model Stock, Pro Series and Off Road applications. Recommended master cylinder sizing is 3/4".

- WIL260-1333**\$73.19**

Slave Cylinder Rebuild Kit

Rebuild kit for Wilwood Slave Cylinder. Contains o-ring seals, spring assembly, inlet fitting and bleed screw. All parts necessary for maintenance and repair of your slave cylinder.

- WIL260-5524**\$13.45**



Tru-Bar 60 Degree Remote Pedal

Master Cylinder Mount

For remote brake pedal applications utilizes a fixed trunnion bearing within the pivot lever and pushrod spherical bearing ends. This provides smooth operation and precise adjustment of the brake bias with zero chance of balance migration, eliminating all side play. A larger dia, higher strength 4340 steel 7/16-20 balance bar adds rigidity and increases bias influence. A step-down shoulder on each end allows use of the direct mount adjusting knob or a standard 3/8-24 coupler remote adjuster cable. The new model is interchangeable with the previous slider bearing model, with upgrade kits available for older units. It's race proven to deliver championship caliber performance in all racing conditions.

- WIL340-14380...**\$229.39**



60 Degree Balance Pedal Assembly

This lightweight unit is ideal for Dirt Modifieds, Champ Cars, Sprint Cars & Midgets where master cylinders must be mounted in a remote location because of tight space constraints. Usually mounted to the driver's left side chassis rail, the unit's balance bar controls two standard mount master cylinders with remote mounted reservoirs. The 60 degree mounting angle allows for tight fit applications and easy accessibility. Strong cast aluminum housing and balance bar weighs only 1.8 pounds. An adjuster knob is included with each assembly.

- WIL340-4630...**\$170.93**



MASTER CYLINDERS

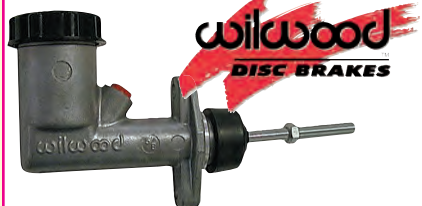

wilwood
DISC BRAKES

Aluminum Master Cylinders

This popular lightweight, compact design is used for clutch & small master cyl requirements and is well known for its dependability. It incorporates an improved plastic screw-on filler cap and is available in all three bore sizes.

5/8" bore.....	WIL260-2636.....	\$48.58
3/4" bore.....	WIL260-1304.....	\$48.58



Aluminum Tandem Chamber Master Cylinder

High-pressure die casting of a premium alloy produces a high-capacity body that is lightweight, looks great, and has the durability for competition. A black anodized, machined billet lid captures a pressure balanced bellows gasket with 100% sealing against moisture invasion or fluid leakage. The mounting flange is slotted to accommodate installation on bolt centers between 3.22" and 3.40".

7/8" Bore Std Finish.....	WIL260-9439.....	\$179.93
7/8" Bore Std Black.....	WIL260-9439-BK.....	\$215.93
7/8" Bore Bright Finish.....	WIL260-9439-P.....	\$215.93
1" Bore Std Finish.....	WIL260-8555.....	\$179.93
1-1/8" Bore Std Finish.....	WIL260-8556.....	\$179.93
1-1/8" Bore Std Black.....	WIL260-8556-BK.....	\$215.93
1-1/8" Bore Bright Finish.....	WIL260-8556-P.....	\$215.93

Tandem Master Cylinder

Made from alum w/a large capacity plastic reservoir, this master utilizes standard OEM internal components. LW master can be used for everything from drag racing to street rods.

1 1/16" bore.....	WIL260-4893.....	\$102.64
Rebuild Kit.....	WIL260-4896.....	\$28.68
Tandem Master Cylinder Kit (includes m/c, boot, pushrod, retainer).....	WIL260-4894.....	\$115.14

TM1 5/8 Tandem Master Cylinder

It is manufactured from LW alum with a 5/8" bore and dual 10mm x 1.00 outlets. Side mounting on 3.53" bolt spacing using 5/16" bolts, it's compact design is perfect for applications where space is limited. Includes push rod, dust boot and a permanent mount .39" dia clevis. An alternative 5/16-24" threaded pushrod is available under part # 230-7134.

7 Ounce Remote Reservoir Kit with 30" of Hose (2 required per master cyl)...WIL260-11097.....**\$93.20**

Knob Style Combination Proportioning Valve

It substantially simplifies mounting, plumbing, wiring and brake proportioning adjustments on vehicles with custom brake systems. The rear circuit has a single inlet and single outlet with the adj proportioning valve. The front circuit has a single inlet with two outlets. It can be run as a single outlet with one outlet plugged, or used to split the plumbing on its way to the front calipers.

WIL260-11179.....**\$80.94**



Remote Master Cylinder Kits

Allows you to place reservoirs in an easy to reach location. Great for race cars.

5/8" bore.....	WIL260-3372.....	\$67.48
3/4" bore.....	WIL260-3374.....	\$67.48
7/8" bore.....	WIL260-3376.....	\$67.48
1" bore.....	WIL260-3378.....	\$67.48
1-1/8" bore.....	WIL260-3380.....	\$67.48

Rebuild Kits

5/8".....	WIL260-3880.....	\$18.69
3/4".....	WIL260-3881.....	\$18.69
7/8".....	WIL260-3882.....	\$18.69
1".....	WIL260-3883.....	\$18.69
1-1/8".....	WIL260-3884.....	\$18.69

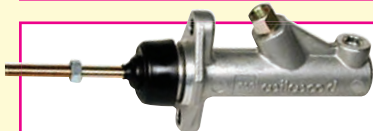

Compact Remote Master Cylinder

They are the perfect solution for club racers, small open wheel racers, and any other custom application when there is limited mounting space for the master cylinder and fluid reservoir. Both fluid ports are located on the top of the cylinder body for additional end clearance in short mounting spaces.

0.625" Bore.....	WIL260-6087.....	\$44.43
0.700" Bore.....	WIL260-6088.....	\$44.43
0.750" Bore.....	WIL260-6089.....	\$44.43

Reservoir Kit, Compact Remote

Small 4 oz.....	WIL260-7577.....	\$53.94
Large 10 oz.....	WIL260-8742.....	\$53.94

Combination Remote Tandem Master Cylinder

This versatile, lightweight and easily adapted master cylinder provides single pushrod activation of two separate brake fluid circuits. The cylinder features 50/50 output from a 1.00" bore with 1.10" stroke.

WIL260-7563.....**\$146.81**

Electric Brake Shut Off

Engineered specifically as a race caliper shut off valve. Line locks are not designed to be kept in the ON position continuously and can overheat and fail if used as a shut-off. Line locks can also trap pressure in the brake system and cause the brakes to drag. Wilwood shut-off valves can be engaged without trapping pressure in caliper (will not drag brake).

WIL260-9921.....**\$139.94**

GM Style Proportioning Valve

Manufactured from high quality aluminum and coated with a durable black anodized finish. Line connections for the valve, if mounted in the OE location, will allow the original lines to connect directly to the valve. If mounted in a non-OE location, fluid lines may have to be modified. This also does allow usage in other non-GM vehicles. This proportioning valve offers: 63% pressure reduction (rear) after 350 PSI knee point. A 30 PSI delay rear-to-front circuit and Circuit failure sensor activation at 50 ± 10 PSI. A Recommended max operating pressure: 2000 PSI. Non-adjustable front-to-rear proportioning (knee point, rate, etc.) and Anti-dive or metering delay valve: Enables rear brake pressure to build momentarily before front brake pressure builds.

WIL260-11322.....**\$89.90**

Compact Combination Master Cyl Kits

Kit features a compact 3.37" lightweight aluminum short body design. The master cylinder provides 1.12" of usable push rod stroke.

5/8" bore.....	WIL260-10371.....	\$75.54
3/4" bore.....	WIL260-10372.....	\$75.54
13/16" bore.....	WIL260-10373.....	\$75.54
7/8" bore.....	WIL260-10374.....	\$75.54
1" bore.....	WIL260-10375.....	\$75.54
1-1/8" bore.....	WIL260-10376.....	\$75.54

Rebuild Kits

5/8" bore.....	WIL260-10513.....	\$21.19
3/4" bore.....	WIL260-10514.....	\$21.19
13/16" bore.....	WIL260-10515.....	\$21.19
7/8" bore.....	WIL260-10516.....	\$21.19
1" bore.....	WIL260-10517.....	\$21.19
1-1/8" bore.....	WIL260-10518.....	\$21.19

Replacement Parts

Reservoir Small 7 oz.....	WIL260-10204.....	\$7.19
Reservoir Large 10 oz.....	WIL260-10205.....	\$7.19
Reservoir Cap.....	WIL330-15081.....	\$6.19
Remote Mount Bkt.....	WIL260-10263.....	\$6.19
Remote Hose.....	WIL220-10444.....	\$6.19
Remote Inlet Adapter.....	WIL260-10264.....	\$3.69
Hose Clamp.....	WIL260-10342.....	\$1.11
O'Ring.....	WIL210-10402.....	\$0.80

Master Cylinder Short Remote, Side Mount

Kit, M/C, 5/8", Short Remote, Side Mt - Reservoir. Unit Weight 2.6 lbs. Width 10.56". Length 13". Height 3".

Bore.....	Part #	
5/8" bore.....	WIL260-12384.....	\$75.54
3/4" bore.....	WIL260-12385.....	\$75.54
13/16" bore.....	WIL260-12386.....	\$75.54
7/8" bore.....	WIL260-12387.....	\$75.54
1" bore.....	WIL260-12388.....	\$75.54
1-1/8" bore.....	WIL260-12389.....	\$75.54

High Volume Alum. Master Cylinder

Bigger calipers require more fluid. These new high volume masters hold 26% more fluid meaning larger reserves and cooler temps.

3/4" bore.....	WIL260-6764.....	\$48.56
7/8" bore.....	WIL260-6765.....	\$48.56
1" bore.....	WIL260-6766.....	\$48.56

Rebuild Kits

3/4".....	WIL260-6898.....	\$28.68
7/8".....	WIL260-6899.....	\$28.68
1".....	WIL260-6900.....	\$28.68

Kart/Jr. Dragster Master Cylinder

Compact and LW master and bkt assembly mounts in std location on most karts & jr. dragsters.

WIL260-5520.....**\$78.69**

Proportioning Valves

Pressure adjustments range from 100-1000 PSI and provide for a maximum decrease of 57% in line pressure, the most of any available valve. Adjuster knob with fine thread tuning provides precise pressure adjustment. This adjustment lets you fine tune the front to rear braking balance by proportionally decreasing the rear brake line pressure. Valves weigh only 5.2 ounces and have two .25" side mounting holes spaced 1.00" apart. Std in and out ports are 1/8-27 NPT.

Knob Style.....	WIL260-8419.....	\$37.75
Lever Style.....	WIL260-8420.....	\$74.93



Code Breakdown

H B 245 x .631

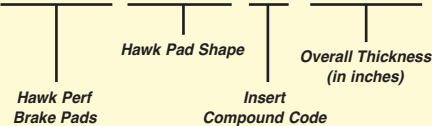

Hawk Brakes provide fade free, longer lasting performance from start to finish. Ferro-Carbon Semi Metallic Racing Pads are burnished with no break-in required, run up to 200°F cooler and provide instant response with no lag. Rotor friendly pads also have a high coefficient of friction and low wear rate. Consistent, predictable performance lap after lap. Proven in NASCAR, Indy Car, SCCA, IMSA, DIRT, Hooters Cup, and ASA.

Code: U	Compound: DTC-70	Torque: High
Designed for high deceleration rates. High temperature fade resistance. Very low abrasive rotor wear.		
Code: G	Compound: DTC-60	Torque: High
Slightly lower torque than DTC 70. Recommended for use with DTC 70 when split friction between front and rear axle is desired. Similar but lower torque profile as DTC 70. Very low abrasive rotor wear.		
Code: V	Compound: DTC-50	Torque: High
Designed for high deceleration rates. High temperature brake fade resistance. Very high torque with aggressive initial bite.		
Code: W	Compound: DTC-30	Torque: Medium
Wide Optimal temperature range. Smooth feel with good initial bite. Good cold effectiveness. Very low abrasive rotor wear.		
Code: A	Compound: DTC-15	Torque: Medium
Designed for high deceleration rates. High temperature fade resistance. Very low abrasive rotor wear.		
Code: H	Compound: DTC-05	Torque: Low
Designed for use in Dirt Track racing. Controllable, higher temp performance.		
Code: L	Compound: MT-4	Torque: High
High initial bite. Designed for pavement circle track under 2800 lbs. Designed for applications not needing high deceleration rates		
Code: MB	Compound: Metallic	Torque: High
Specifically designed for ceramic coated rotors		
Code: M	Compound: Black	Torque: Medium
Medium torque and temperature pad. Good cold effectiveness. A good all-purpose low-cost racing brake pad. Good for Dirt Modified and IMCA style pavement Modified		

Brake Bias Gauges



They actual front and rear line pressure for making brake bias changes before or during the race. Pre-assembled units have 0-1000 psi liquid filled gauges with 1/8" NPT male fittings and bleeder valves to evacuate air from the gauges. 2-3/4" x 4-1/2" pre-drilled panels are offered in horizontal or vertical versions. ALL80170...\$69.99

Brake Pressure Tester Kit



Accurately measure brake bias without permanently plumbing your car for gauges. Simply screw the fitting onto your caliper bleed screw and have a helper press the brakes. Its face swivels to allow easy readings from any angle. These gauges work best in pairs, one on a front caliper and another in the rear. JOE44012...\$89.95

1000 Series Brake Caliper

- Piston Size 1.75"
- Rotor Width .38" • Mt Holes 3.25"
- BRPBR170-1526...\$131.93



2800 Series Brake Caliper

- Piston Size 1.75"/1.75"
- Rotor Width .810" Right/Left
- BRPBR170-4090...\$205.60



Radial Mt Brake Calipers

Simple. Advantages of this design include, less bracket flex, easy rotor to caliper spacing, multiple size rotors can be used with the same bracket, and simple removal and installation for service. They also offer considerable weight reductions compared to standard calipers.



- BRPBR170-53753/8" Rotor\$229.98
- BRPBR170-5810810" Rotor\$219.26

Wilwood DL Outlaw Sierra

- DTC-05 Compound 12 mm ThickHAWHB100H.480...\$53.43
- MT-4 Compound 12 mm Thick.....HAWHB100L.480...\$71.65
- Black Compound 12 mm Thick.....HAWHB100M.480...\$63.62
- DTC-30 Compound 12 mm ThickHAWHB100W.480...\$66.06

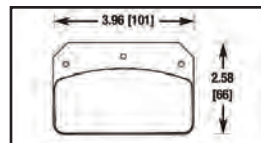

Wilwood SL AP Racing Outlaw

- DTC-60 Compound 20 mm ThickHAWHB101G.800...\$176.46
- DTC-05 Compound 20 mm ThickHAWHB101H.800...\$84.25
- MT-4 Compound 20 mm Thick.....HAWHB101L.800...\$140.48
- Black Compound 20 mm Thick.....HAWHB101M.800...\$99.37
- DTC-70 Compound 20 mm ThickHAWHB101U.800...\$178.55
- DTC-30 Compound 20 mm ThickHAWHB101W.800...\$124.01

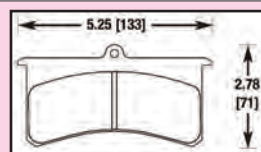

GM Intermediate

- DTC-60 Compound 15 mm ThickHAWHB103G.590...\$126.93
- DTC-05 Compound 15 mm ThickHAWHB103H.590...\$58.09
- MT-4 Compound 15 mm Thick.....HAWHB103L.590...\$124.77
- HT-10 Compound 15 mm ThickHAWHB103S.590...\$148.04
- DTC-70 Compound 15 mm ThickHAWHB103U.590...\$161.76
- DTC-30 Compound 15 mm ThickHAWHB103W.590...\$97.34

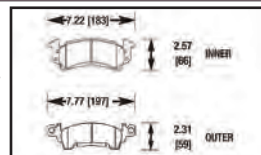

GM Metric

- DTC-60 Compound 15 mm ThickHAWHB119G.594...\$115.89
- DTC-05 Compound 15 mm ThickHAWHB119H.594...\$48.17
- MT-4 Compound 15 mm ThickHAWHB119L.594...\$127.20
- Black Compound 15 mm ThickHAWHB119M.594...\$74.93
- DTC-70 Compound 15 mm ThickHAWHB119U.594...\$145.21
- DTC-30 Compound 15 mm ThickHAWHB119W.594...\$97.34

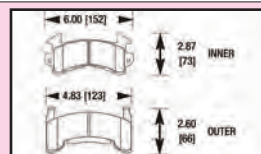

GM Magnum

- MT-4 Compound 15 mm Thick.....HAWHB131L.595...\$129.62
- Black Compound 15 mm ThickHAWHB131M.595...\$74.93
- DTC-70 Compound 15 mm ThickHAWHB131U.595...\$164.89
- DTC-30 Compound 15 mm ThickHAWHB131W.595...\$97.34

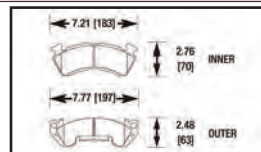

Wilwood BB AP Racing Outlaw

- DTC-05 Compound 16 mm ThickHAWHB237H.625...\$52.31
- MT-4 Compound 16 mm Thick.....HAWHB237L.625...\$72.10
- Black Compound 16 mm ThickHAWHB237M.625...\$65.88
- DTC-70 Compound 16 mm ThickHAWHB237U.625...\$89.75
- DTC-30 Compound 16 mm Thick NDL.....HAWHB237W.625...\$85.04

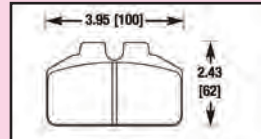

Wilwood BB SL

- DTC-60 Compound 20 mm ThickHAWHB521G.800...\$182.19
- DTC-05 Compound 20 mm ThickHAWHB521H.800...\$88.21
- MT-4 Compound 20 mm Thick.....HAWHB521L.800...\$143.02
- Black Compound 20 mm Thick.....HAWHB521M.800...\$101.91
- DTC-70 Compound 20 mm ThickHAWHB521U.800...\$187.84
- DTC-30 Compound 20 mm ThickHAWHB521W.800...\$128.73

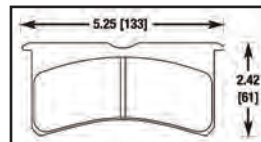

Wilwood

- DTC-60 Compound 15 mm ThickHAWHB542G.600...\$97.14
- DTC-70 Compound 15 mm ThickHAWHB542U.600...\$120.32
- DTC-30 Compound 15 mm ThickHAWHB542W.600...\$94.92

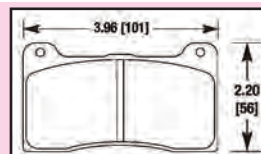

Powerlite Wilwood

- DTC-05 Compound 12 mmHAWHB611H.490...\$72.21
- Black Compound 12 mmHAWHB611M.490...\$77.37
- DTC-30 Compound 12 mmHAWHB611W.490...\$87.68

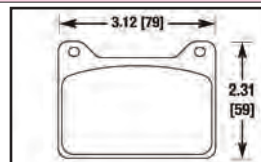

Wilwood DLS new style

- Black Compound 12 mmHAWHB622M.490...\$69.11
- DTC-30 Compound 12 mmHAWHB622W.490...\$72.21

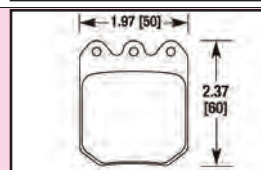

Brake Balance Bar Assembly

(No Master Cylinders)

More precise adjustment. Constant bias bumps and chassis movement do not affect the balance bar like traditional balance bar assemblies. No pedal dead spot because the balance bar doesn't work off of a pivot point. Balance bar has roller bearing adjustment for smoother operation. Knob has detent so bias can't change during racing conditions. BRPBR310-9070...\$328.92

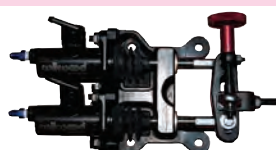

wilwood Quick Check Pressure Gauge



This easy to read two inch diameter non-hazing face allows for quick brake line pressure checks from 0-1,500 PSI (or 0-10,000 kPa). 20 PSI graduations and accuracy to 1.5% permit reliable brake bias setup and brake system troubleshooting. It is durable and corrosion resistant. WL260-0966...\$62.43

PFC Racing Compounds



The sets are completely race ready pads requiring no bedding. All pads are boxed per axle set, four pads per box. All PFC compounds are painted black.

Swept Depth	Part #
46 GM Intermediate	PFC0052.11.14.44 \$.92.95
46 GM Intermediate	PFC0052.13.14.44 \$.148.67
46 GM Intermediate	PFC0052.14.14.44 \$.92.95

Swept Depth	Part #
42 GM Metric	PFC0154.11.14.44 \$.92.95
42 GM Metric	PFC0154.14.14.44 \$.92.95
42 GM Metric	PFC0154.13.14.44 \$.149.93

Swept Depth	Part #
40 AP, Outlaw, Wilwood Superlite	PFC7751.11.20.44 \$.184.95
40 AP, Outlaw, Wilwood Superlite	PFC7751.13.20.44 \$.222.26
40 AP, Outlaw, Wilwood Superlite	PFC7751.14.20.44 \$.92.95
40 AP, Outlaw, Wilwood Superlite	PFC7751.81.20.44 \$.110.59

Swept Depth	Part #
46 Outlaw, Sierra, Wilwood DL	PFC7752.14.12.44 \$.74.94
46 Outlaw, Sierra, Wilwood DL	PFC7752.81.12.44 \$.73.95
46 Outlaw, Sierra, Wilwood DL	PFC7752.97.12.44 \$.92.58

Swept Depth	Part #
45 AP6, Wilwood, JFZ	PFC7753.11.21.44 \$.230.95

Swept Depth	Part #
46 Outlaw, Wilwood B/Bolt, NDL	PFC7754.11.16.44 \$.120.79
46 Outlaw, Wilwood B/Bolt, NDL	PFC7754.14.16.44 \$.73.95
46 Outlaw, Wilwood B/Bolt, NDL	PFC7754.81.16.44 \$.73.95
46 Outlaw, Wilwood B/Bolt, NDL	PFC7754.97.16.44 \$.92.95

Swept Depth	Part #
43 Outlaw, Wilwood Single	PFC7757.11.12.44 \$.55.72
43 Outlaw, Wilwood Single	PFC7757.14.12.44 \$.55.72
43 Outlaw, Wilwood Single	PFC7757.97.12.44 \$.55.95

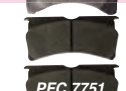

Compound	Description
11	Medium friction - the ultimate in control, with super disc conditioning. Developed from 01 compound with improved bite, modulation, and release characteristics. Ultra smooth and eliminates wheel lock. Applications: Ideal use for medium to low grip venues as well as racing venues where ABS is used.
12	Medium friction - great control and for 24 hour durability and super disconditioning. Developed from 08 compound with improved wear, modulation and release characteristics and the ultimate in wear. Applications: Ideal use for endurance where long wear is at premium and where ABS systems are used.
13	High friction - a new generation of ultimate high bite. Developed from 01 compound with increased bite, modulation, and superior disc conditioning and release characteristics for exceptional control. Applications: Ideal use for sprint and severe applications - heavy fast cars or high downforce cars.
14	Lighter friction - medium distance friction with ultimate control and superior disc conditioning. Developed from 01 compound with lower cold bite and reducing wheel lock at the end of a stop. Applications: Ideal use for medium to low grip venues where control and modulation is a premium.
01	Good initial bite, with very little torque rise with temperature for improved modulation and excellent release. Wins more World and National Championships annually than any compound on the market. Applications: All purpose pad in a wide variety of applications such as road course, oval track, and short track.
07	Higher initial bite and higher average torque. It will have some friction rise with temp for most severe apps. Great modulation and release characteristics with low abraded disc wear. Applications: For high grip, high downforce, or severe duty apps such as Nascar Short Track and Indy Cars.
08	Slight friction rise with temp with excellent release and modulation characteristics. Very low abraded disc wear with a fine grey slate like disc finish, similar to the 01. Applications: For when smooth initial bite is a must such as SCCA racing, endurance sportscar and GT.

Brake Bottle Bleeder Kit

It contains the mess of bleeding brakes by capturing the fluid in a 16oz. bottle. It comes with a magnetic adapter that attaches directly to your brake disc to make brake bleeding a one-man job. The one-way check valve is easy to use, just attach the bottle, open the bleed screw and pump the brakes. Each pump releases fluid out of the system and seals tight when you release the pedal. It works for the majority of brake systems without the need for an adapter.

JOE44010.....**\$.20.95**

Brake Bottle Bleeder Kit Longacre

Magnet holds bottle while you bleed your brakes ~ no more spilled fluid. Hoses connect to bleeder valves - bleed one at a time or both at once. Cap for hoses prevents leakage during storage. Kit includes 2 bottles and comes with 1/4" bleed wrench.

LON45200.....**\$.32.57**

Electric Right Front Brake Shut-Off

Disable right front brake with the flip of a switch. Commonly found on dirt modified and late models, electric shut-off helps turn the car on entry when track conditions are heavy/wet. Kit electronically disables the right front brake yet allows brake pressure to bleed-off from the right front brake caliper unlike manual shut off valves. Detailed installation instructions are included. Contents: Brake Solenoid, (2) 1/8" NPT to 3/16" Inverted Flare (3/8"-24). ALL48017.....**\$.79.99**



ZR24 Caliper

Brake Caliper, ZR24, Front, Driver Side, 4 Piston, Aluminum, Red, 12.716 in OD x 1.250 in Thick Rotor, 4.75 in Radial Mount...PFC7754.13.16.44...**\$.148.68**



Northeast Modified Pkg - Front

Calipers (Top Mount L/R) PFC24.284.255.290.01A/02A.....**\$.799.00**

Bracket (Qty) (x2) Small & Large Bearing.....PFC120.040.451.01.....**\$.154.56**

Discs (L/R) (11.18 x 0.75) V3.....PFC284.19.0035.452/462.....**\$.185.85**

Hats Large Bearing.....PFC195.162.070.15.....**\$.148.67**

Small Bearing.....PFC195.127.130.15.....**\$.255.61**

Race Pad Set PFC ZR24 Caliper.....PFC7835.XX.XX.44.....**\$.Call**

Northeast Modified Pkg - Rear

Calipers (Top Mount L/R) Black Anodized.....PFC94.323.410.440.01A/02A.....**\$.499.95**

Nickel Plated w/Insulators.....PFC94.323.410.440.01/02.....**\$.499.95**

Bracket (Qty) (x2) PFC ZR94 Caliper.....PFC180.028.158.01.....**\$.69.80**

Discs (L/R) (11.75 x 0.81) V3.....PFC299.20.0040.452/462.....**\$.204.44**

(11.75 x 1.25) V3 Option.....PFC299.32.0040.452/462.....**\$.204.44**

(11.75 x 1.25) 8 Bolt/7" Option.....PFC299.32.0040.01/02.....**\$.167.26**

(11.75 x 0.81) 8 Bolt/7" Option.....PFC299.20.0040.01/02.....**\$.167.26**

Hats Lightweight 5 x 5.....PFC195.108.080.15.....**\$.255.61**

8 Bolt Hub.....PFC195.162.070.15.....**\$.148.67**

5 Bolt Hub.....PFC195.108.147.15.....**\$.368.85**

Race Pad Set PFC ZR94 1.25 Disc.....PFC7834.XX.19.44.....**\$.Call**

Pro Option .810 Disc.....PFC7905.XX.25.44.....**\$.Call**

PFC 665 Race Fluid Bottle.....PFC025.0037.....**\$.27.97**

Case.....PFC025.0038.....**\$.188.79**

Northeast Modified Disc/Pad Pkg - Front

Race Pad Set WW/Bicknell Caliper.....PFC7757.XX.12.44.....**\$.Call**

WW/Bicknell Caliper/ST Caliper.....PFC7754.XX.16.44.....**\$.Call**

Northeast Modified Disc/Pad Pkg - Rear

Discs (L/R) (11.75 x 0.81).....PFC299.20.0040.452/462.....**\$.204.44**

(11.75 x 1.25) V3 Option.....PFC299.32.0040.452/462.....**\$.204.44**

(11.75 x 1.25) 8 Bolt/7" Option.....PFC299.32.0040.01/02.....**\$.167.26**

(11.75 x 0.81) 8 Bolt/7" Option.....PFC299.20.0040.01/02.....**\$.167.26**

(11.61 x 1) 8 Bolt/7" Option.....PFC299.25.0038.01/02.....**\$.Call**

Hats 8 Bolt Hub.....PFC195.162.070.15.....**\$.148.67**

5 Bolt Hub.....PFC195.108.147.15.....**\$.368.85**

Lightweight 5 x 5.....PFC195.108.080.15.....**\$.255.61**

Race Pad Set RP/WW/TBM/ST Caliper.....PFC7751.XX.20.44.....**\$.Call**

WW/Bicknell Caliper.....PFC7754.XX.16.44.....**\$.Call**

PFC 665 Race Fluid Bottle.....PFC025.0037.....**\$.27.97**

Case.....PFC025.0038.....**\$.188.79**

RH665 DOT 4 Racing Brake Fluid

RH665 has the highest guaranteed minimum Dry Boiling Point of any DOT 4 Brake Fluid to guard against Vapor Lock and give a rock hard pedal even under extreme racing conditions. RH665 also maintains its class leading viscosity, lubricity and compressibility performance at extreme temperatures, to maintain braking system reliability and performance. For best results bleed the system with fresh fluid before each event, especially if the brakes are excessively hot and/or the conditions are humid. RH665 can safely be mixed with other DOT 4 Brake Fluids however this will degrade its properties. RH665 Racing Brake Fluid conforms to and exceeds the current specification U.S. FMVSS No.116 DOT 4. Minimum Dry Boiling Point (guaranteed): 325oC (617oF) Typical Dry BP approaching 330oC. Street Legal - Rock hard pedal

500 ml.....PFC025.0037.....**\$.27.97**

Box of 12.....PFC025.0038.....**\$.188.79**

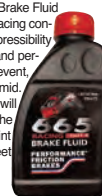

Late Model/Modified/Nascar

PFC's late model/modified brake rotors are made from superior alloys to resist cracking and are offered in smooth or slotted designs. Directional vanes control air flow and increase brake performance and durability. Advanced pattern on slotted rotor enhances pad bite and reduces thermal distortion. All rotors listed are 8-bolt with a 7" bolt cir.

Description ..PFC Pad Shape	Part #
11.75" Dia. x .810" Thick	0052/7752/7754
LH.....	PFC299.20.0045.01..... \$.169.95
RH.....	PFC299.20.0045.02..... \$.169.95
11.75" Dia. x 1.250" Thick	7736/7751
LH.....	PFC299.32.0040.01..... \$.167.26
RH.....	PFC299.32.0040.02..... \$.167.26

*Includes rotor bolt kit





-3 Brake Lines

**NOT FOR
HIGHWAY USE**

Stainless Steel

Size	Straight	Price
-3 x 4"	BRA304	\$6.45
-3 x 5"	BRA305	\$6.45
-3 x 10"	BRA310	\$6.99
-3 x 12"	BRA312	\$7.38
-3 x 14"	BRA314	\$8.04
-3 x 15"	BRA315	\$8.13
-3 x 16"	BRA316	\$8.55
-3 x 18"	BRA318	\$8.79
-3 x 20"	BRA320	\$9.27
-3 x 21"		
-3 x 22"	BRA322	\$9.99
-3 x 24"	BRA324	\$10.17
-3 x 26"	BRA326	\$10.98
-3 x 28"	BRA328	\$11.37
-3 x 30"	BRA330	\$11.58
-3 x 32"	BRA332	\$12.36
-3 x 36"	BRA336	\$12.87
-3 x 42"	BRA342	\$14.04
-3 x 45"	BRA345	\$15.00
-3 x 48"	BRA348	\$15.48
-3 x 50"		
-3 x 55"	BRA355	\$16.02
-3 x 60"		
-3 x 72"	BRA372	\$21.81
-3 x 90"	BRA390	\$24.93
-3 x 96"	BRA396	\$27.12
-3 x 102"	BRA3102	\$29.25
-3 x 105"	BRA3105	\$30.12

90°	Price
BRA3159	\$10.62
BRA3189	\$11.25
BRA3209	\$11.76
BRA3229	\$12.39
BRA3249	\$12.72
BRA3289	\$13.56
BRA3309	\$14.01
BRA3329	\$16.50
BRA3369	\$16.02
BRA3489	\$18.90

Poly Coated

Straight	Price
BRA312-C	\$9.66
BRA315-C	\$10.47
BRA318-C	\$11.31
BRA322-C	\$12.15
BRA324-C	\$12.99
BRA326-C	\$14.04
BRA328-C	\$14.58
BRA330-C	\$14.67
BRA336-C	\$16.29

90°	Price
BRA3159-C	\$14.91
BRA3189-C	\$16.23
BRA3229-C	\$18.09
BRA3249-C	\$19.02
BRA3309-C	\$21.24
BRA3369-C	\$23.52
BRA3489-C	\$27.21

Black Coated Aluminum Nut

Straight	Price
BRA312-AC	\$10.05
BRA315-AC	\$10.95
BRA318-AC	\$11.73
BRA321-AC	\$12.60
BRA324-AC	\$11.82
BRA330-AC	\$15.03
BRA336-AC	\$16.74
BRA350-AC	\$23.01
BRA355-AC	\$22.80
BRA360-AC	\$22.80



-4 Brake Line

**NOT FOR
HIGHWAY USE**

Stainless Steel

Size	Straight	Price
-4 x 10"	BRA410	\$9.69
-4 x 12"	BRA412	\$9.69
-4 x 14"	BRA414	\$10.29
-4 x 15"	BRA415	\$10.62
-4 x 16"	BRA416	\$11.34
-4 x 18"	BRA418	\$11.58
-4 x 20"	BRA420	\$12.27
-4 x 22"	BRA422	\$13.20
-4 x 24"	BRA424	\$13.56
-4 x 28"	BRA428	\$14.85
-4 x 30"	BRA430	\$15.30
-4 x 34"	BRA434	\$15.93
-4 x 36"	BRA436	\$17.19
-4 x 40"	BRA440	\$19.14
-4 x 42"	BRA442	\$20.13
-4 x 45"	BRA445	\$20.37
-4 x 48"	BRA448	\$21.00
-4 x 60"	BRA460	\$25.74
-4 x 72"	BRA472	\$38.16
-4 x 83"	BRA483	\$53.28

90°	Price
BRA4129	\$14.16
BRA4159	\$14.91
BRA4189	\$15.90
BRA4209	\$16.26
BRA4229	\$17.07
BRA4249	\$17.46
BRA4309	\$19.47
BRA4369	\$21.36
BRA4409	\$22.65
BRA4489	\$25.11

For Late Models

Poly Coated Pre Made Brake Lines	BRA418-1/8CB	-4X18"	\$22.74
-4 Straight · 1/8" NPT male	BRA424-1/8CB	-4X24"	\$27.00

25' Steel Line
 3/16".....BSC70300\$22.77
 1/4".....BSC70400\$22.75

Brass "T"
 3/8" - 24 IF on all three ends
 EAR972052\$12.63
 3/8" - 24 IF on sides, 3/8" -
 24 straight on T
 EAR972050\$12.63

Brake Fittings
 3/16" Inverted Flare Union
 (4-Pack).....ALL50130.....\$5.89

Shut-Off Valve
 It has 1/8" NPT inlet & outlet and is
 rated at 2,000 PSI. Size: 1/2"
 wide, 1-3/4" long & 1-9/16" high.
 ALL48010.....\$48.99

EARL'S Alum Tube Nut & Sleeve
 Nuts & Sleeves for fitting ends of brake lines.
 -3 to 3/16" Nuts pr.....EAR581803. \$4.97
 -4 to 1/4" Nuts pr.....EAR581804. \$4.97
 -3 to 3/16" Sleeves pr EAR581903. \$3.21
 -4 to 1/4" Sleeves pr ..EAR581904. \$3.36

Steel Tube
 -3 to 3/16" Nuts pr.....EAR561803. \$3.97
 -4 to 1/4" Nuts pr.....EAR561804. \$5.97
 -3 to 3/16" Sleeves pr EAR561903. \$3.04
 -4 to 1/4" Sleeves pr ..EAR561904. \$3.04

Speed-Seal Hose Ends
 -3 St EAR600103. \$8.14
 -4 St EAR600104. \$9.17
 -3 90° EAR609103. \$14.29
 -4 90° EAR609104. \$14.80



Steel Brake Line SAE Inverted Flare

3/16" x 8".....	BSC70308.....	\$1.94
3/16" x 12".....	BSC70312.....	\$1.94
3/16" x 20".....	BSC70320.....	\$2.26
3/16" x 30".....	BSC70330.....	\$2.74
3/16" x 40".....	BSC70340.....	\$3.40
3/16" x 51".....	BSC70351.....	\$4.10
3/16" x 60".....	BSC70360.....	\$4.42

Brake Deflectors

Guard your brake lines from flying rocks with these anodized aluminum deflectors.
 RedLeftBRP42L.....\$9.33
 RedRightBRP42R.....\$9.33
 RedLeftBRP42LBK.....\$9.33
 RedRightBRP42RBK.....\$9.33

Chassis Line Clamp

This clamp is the best way to mount that rear brake line to keep it out of harms way.
 2-1/8" ... BRP9363\$16.69
 3"..... BRP9377\$21.78



Caliper Adapters

Fits most aftermarket calipers with 1/8 pipe taper inlet.

	aluminum	steel
-3 to 1/8 NPT straight.....	EAR981603.....\$3.12.....	EAR961603.....\$2.96
-4 to 1/8 NPT straight.....	EAR981604.....\$3.19.....	EAR961604.....\$2.14
-3 to 1/8 NPT 90°.....	EAR982203.....\$8.24.....	EAR962203.....\$7.74
-4 to 1/8 NPT 90°.....	EAR982204.....\$8.36.....	EAR962204.....\$5.12

Banjo Adapters

Fits most OEM and aftermarket GM type calipers.

Banjo Fitting

hole size thread

3/8".....	-3 AN.....	EAR997603.....\$8.27
10mm.....	-3 AN.....	EAR997631.....\$8.30
7/16".....	-3 AN.....	EAR997634.....\$8.54
3/8".....	-4 AN.....	EAR997643.....\$9.36
10mm.....	-4 AN.....	EAR997641.....\$9.36
7/16".....	-4 AN.....	EAR997604.....\$9.09

Banjo Bolt

3/8" - 24UNF.....	EAR977503.....\$5.58
10mm x 1.0.....	EAR977517.....\$5.58
7/16" - 24 inverted flare.....	3AN.....EAR989549.....\$6.29
3/8" - 24 inverted flare.....	4AN.....EAR989532.....\$5.85
3/8" - 24 flare.....	4AN.....EAR989541.....\$5.85
10mm x 1.0 bubble flare.....	4AN.....EAR989542.....\$6.92
10mm x 1.0 inverted flare.....	4AN.....EAR989544.....\$6.92

female side

3/8" - 24 inverted flare.....	3AN.....	EAR989543.....\$5.85
10mm x 1.0 bubble flare.....	3AN.....	EAR989534.....\$5.85
10mm x 1.0 inverted flare.....	3AN.....	EAR989545.....\$5.85
7/16" - 24 inverted flare.....	3AN.....	EAR989549.....\$6.29
3/8" - 24 inverted flare.....	4AN.....	EAR989532.....\$5.85
3/8" - 24 flare.....	4AN.....	EAR989541.....\$5.85
10mm x 1.0 bubble flare.....	4AN.....	EAR989542.....\$6.92
10mm x 1.0 inverted flare.....	4AN.....	EAR989544.....\$6.92

Chassis Mount Threaded Adapters Female to male threaded adapters

Speed-Flex SS Braided/Teflon Hose

We recommend -3 lines for brakes because they produce higher pressure with little fluid displacement. Clutch systems on the other hand require less pressure, but more displacement of fluid, so we recommend -4 lines for them. Use only w/Speed-Seal hose ends.

size	10'	20'
-3	EAR610003.....\$35.81	EAR620003.....\$68.51
-4	EAR610004.....\$45.30	EAR620004.....\$86.43

Nylon Brake Line Kit

Kit extends from the master cylinder to the caliper and includes 35 feet of 3/16" line, compression ends, unions, tees and 1/8" NPT fittings. Race proven for years. Not for street use.
 ALL48030.....\$64.99

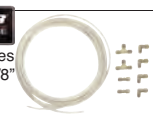



Draco Springs

Draco Springs is the global leader in spring manufacturing. A family owned and operated business since 1969, Draco specializes in a wide variety of springs, from government contracted specs to the tight tolerances of NASCAR racing. Draco now offers a premier spring line for all levels of racing, worldwide. Draco Front Springs are available in several different sizes for various applications including dirt and asphalt late models. Draco manufactures these springs with the fewest coils and largest coil gap on the market with the maximum amount of coil removed to keep weight down to achieve maximum travel with a linear rate. These springs are designed for the racer who demands quality and consistency.

1.875" x 8"

Rates: 50, 60, 65, 75, 80, 85, 90, 100, 110, 115, 120, 125, 130, 140, 150, 160, 170, 175, 180, 185, 190, 195, 200, 210, 215, 220, 225, 230, 240, 250, 260, 270, 275, 280, 290, 300, 310, 315, 320, 325, 330, 340, 350, 360, 370, 375, 380, 385, 390, 400, 425, 450, 475, 500, 525, 550, 575, 600.

DRA.L8.1.875.(Rate)**\$84.00**

1.875" x 10"

Rates: 50, 60, 65, 75, 85, 90, 100, 115, 120, 125, 130, 140, 150, 160, 170, 175, 180, 185, 190, 195, 200, 210, 215, 220, 225, 230, 240, 250, 260, 270, 275, 280, 290, 300, 310, 315, 320, 325, 330, 340, 350, 360, 370, 375, 380, 390, 400, 425, 450, 475, 500, 525, 550, 575, 600.

DRA.L10.1.875.(Rate)**\$84.00**



2.5" x 8"

Rates: 50, 75, 100, 125, 140, 150, 160, 175, 185, 200, 225, 250, 275, 300, 325, 350, 375, 400, 425, 450, 475, 500, 525, 550, 575, 600, 625, 650, 675, 700, 725, 750, 775, 800, 825, 850, 900, 950, 1000, 1050, 1100, 1150, 1200

DRA.C8.2.5.(Rate)**\$80.00**

2.5" x 10"

Rates: 50, 75, 100, 125, 140, 150, 160, 175, 185, 200, 225, 250, 275, 300, 325, 350, 375, 400, 425, 450, 475, 500, 525, 550, 575, 600, 625, 650, 675, 700, 725, 750, 775, 800, 825, 850, 900, 950, 1000, 1050, 1100, 1150, 1200

DRA.C10.2.5.(Rate)**\$90.00**

2.5" x 12"

Rates: 50, 75, 100, 125, 140, 150, 160, 175, 185, 200, 225, 250, 275, 300, 325, 350, 375, 400, 425, 450, 475, 500, 525, 550, 575, 600, 625, 650, 675, 700, 725, 750, 775, 800, 825, 850, 900, 950, 1000, 1050, 1100, 1150, 1200

DRA.C12.2.5.(Rate)**\$90.00**

2.5" x 14"

Rates: 50, 75, 100, 125, 140, 150, 160, 175, 185, 200, 225, 250, 275, 300, 325, 350, 375, 400, 425, 450, 475, 500, 525, 550, 575, 600, 625, 650, 675, 700, 725, 750, 775, 800, 825, 850, 900, 950, 1000, 1050, 1100, 1150, 1200

DRA.C14.2.5.(Rate)**\$100.00**



3" x 8"

Rates: 50, 75, 100, 125, 140, 150, 160, 175, 185, 200, 225, 250, 275, 300, 325, 350, 375, 400, 425, 450, 475, 500, 525, 550, 575, 600, 625, 650, 675, 700, 725, 750, 775, 800, 825, 850, 900, 925, 950, 1000, 1050, 1100, 1150, 1200

DRA.C8.3.0.(Rate)**\$80.00**

3" x 10"

Rates: 50, 75, 100, 125, 140, 150, 160, 175, 185, 200, 225, 250, 275, 300, 325, 350, 375, 400, 425, 450, 475, 500, 525, 550, 575, 600, 625, 650, 675, 700, 725, 750, 775, 800, 825, 850, 900, 950, 1000, 1050, 1100, 1150, 1200

DRA.C10.3.0.(Rate)**\$90.00**

3" x 12"

Rates: 50, 75, 100, 125, 140, 150, 160, 175, 185, 200, 225, 250, 275, 300, 325, 350, 375, 400, 425, 450, 475, 500, 525, 550, 575, 600, 625, 650, 675, 700, 725, 750, 800, 825, 850, 900, 950, 1000, 1050, 1100, 1150, 1200

DRA.C12.3.0.(Rate)**\$100.00**

3" x 12" Progressive Rates: 150, 175

DRA.C12.3.0.(Rate)**\$100.00**

3" x 14"

Rates: 50, 75, 100, 125, 140, 150, 160, 175, 180, 185, 200, 225, 250, 275, 300, 325, 350, 375, 400, 425, 450, 475, 500, 525, 550, 575, 600, 625, 650, 675, 700, 725, 750, 775, 800, 825, 850, 900, 950, 1000, 1050, 1100, 1150, 1200

DRA.C14.3.0.(Rate)**\$120.00**

3" x 16"

Rates: 50, 65, 75, 100, 125, 140, 150, 160, 175, 185, 200, 225, 250, 275, 300, 325, 350, 375, 400

DRA.C16.3.0.(Rate)**\$140.00**

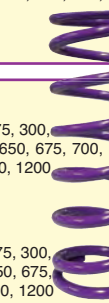

Front 8.75" x 5.5"

Rates: 300, 325, 350, 375, 400, 425, 450, 475, 500, 525, 550, 575, 600, 625, 650, 675, 700, 725, 750, 775, 800, 825, 850, 875, 900, 925, 950, 975, 1000, 1050, 1100, 1150, 1200, 1250, 1300, 1350, 1400, 1450, 1500, 1550, 1575, 1600, 1650, 1700, 1750, 1800, 1850, 1900, 1950, 2000, 2100, 2200, 2300, 2400

DRA.FS.(Rate)**\$230.00**

Front 5.5" x 9.5"

Rates: 225, 250, 275, 300, 325, 350, 375, 400, 425, 450, 475, 500, 525, 550, 575, 600, 625, 650, 675, 700, 750, 800, 850, 900, 950, 1000.

DRA.LM9.5.(Rate)**\$155.00**

Front 5.5" x 10.5"

Rates: 200, 225, 250, 275, 300, 325, 350, 375, 400, 425, 450, 475, 500, 525, 550, 575, 600, 625, 650, 675, 700, 750, 800, 850, 900, 950, 1000.

DRA.LM10.5.(Rate)**\$155.00**

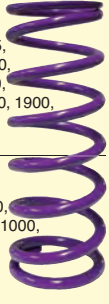

Rear 5" x 11"

Rates: 100, 125, 140, 150, 160, 175, 185, 200, 225, 250, 275, 300, 325, 350, 375, 400, 425, 450, 475, 500, 525, 550, 575, 600, 625, 650, 675, 700, 725, 750, 775, 800, 850, 900, 950, 1000, 1025, 1050, 1100, 1150, 1200

DRA.R11.(Rate)**\$155.00**

Rear 5" x 13"

Rates: 150, 175, 200, 225, 250, 275, 300, 325, 350, 400, 450.

DRA.SR13.(Rate)**\$224.25**

Standard Rear 5" x 14"

Rates: 75, 100, 125, 140, 150, 160, 175, 185, 200, 225, 250, 275, 300, 325, 350, 375, 400, 425, 450, 475, 500, 525, 550, 575, 600, 625, 650, 675, 700, 725, 750, 775, 800, 850, 900, 950, 1000, 1050, 1100, 1150, 1200, 1250, 1275, 1400, 1600

DRA.SR14.(Rate)**\$230.00**

Rear 16" FL (5" x 16")

Rates: 75, 90, 100, 125, 140, 150, 160, 175, 185, 200, 225, 250, 275, 300, 325, 350, 375, 400

DRA.SR16.(Rate)**\$230.00**



Spring Adapter

2.50 - 3.00 Adapter

DRA.2.5.3.0.ADP**\$14.75**

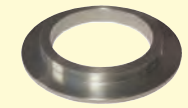

Coil Over Spring Rubbers

Medium Spring RubberDRA.MSR.1.0**\$40.00**
Hard Spring RubberDRA.HSR.1.0**\$40.00**

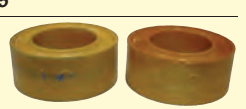

Thrust Bearing Kits

Bearing kits are placed between the coil spring and the adjuster nut to reduce friction when making adjustments. Kits are recommended for preloaded spring assemblies or when springs require adjustment while they are under pressure. Kits include 1 bearing and 2 races. 2" (2.5" I.D. x 3.25" O.D.)

ALL64210...**\$19.99**



2-1/2" to 3" Coil Spring Adapter

BRP9528.....**\$16.71**



HYPERCOILS

2-1/2" x 7"

Rates: 175, 200, 275, 300, 350, 400, 450, 475, 500, 550, 600, 650, 700, 750, 800, 850, 900, 950, 1000, 1100, 1200, 1300.
HYP187B(Rate).....\$58.17

2-1/2" x 8"

Rates: 100, 150, 200, 225, 250, 275, 300, 325, 350, 375, 400, 425, 450, 475, 500, 525, 550, 575, 600, 650, 700, 750, 800, 850, 900, 950, 1000, 1100, 1200
HYP188B(Rate).....\$58.17

2-1/2" x 10"

Rates: 095, 110, 125, 150, 162, 175, 200, 225, 250, 275, 300, 325, 350, 375, 400, 425, 450, 475, 500, 525, 550, 575, 600, 625, 650, 700, 725, 750, 800, 850, 900
HYP1810B(Rate).....\$58.17

2-1/2" x 12"

Rates: 085, 095, 110, 125, 150, 162, 175, 185, 200, 225, 250, 275, 300, 325, 350, 375, 400, 425, 450, 475, 500, 550, 575, 600, 650, 700, 750, 800, 850.
HYP1812B(Rate).....\$58.17

2-1/2" x 14"

Rates: 085, 100, 110, 125, 138, 150, 160, 175, 185, 200, 225, 250, 275, 300, 325, 350, 375, 400.
HYP1814B(Rate).....\$58.17
450, 500, 600, 650.
HYP1814B(Rate).....\$87.25

2-1/2" x 16"

Rates: 100, 150, 250, 300, 350, 450, 500, 600.
HYP1816B(Rate).....\$99.63

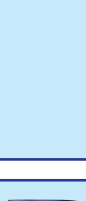
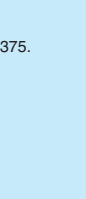
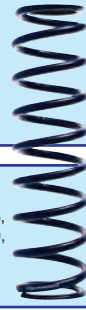

2-1/2" x 12" Ultra High Travel

Rates: 110, 125, 150, 162, 175, 185, 200, 212, 225, 237, 250, 275, 300, 325.
HYP12B0(Rate)UHT.....\$75.91

2-1/2" x 14" Ultra High Travel

Rates: 125, 140, 150, 165, 175, 185, 200, 212, 225, 237, 250.
HYP14B0(Rate)UHT.....\$75.91

2-1/2" x 16" Ultra High Travel

Rates: 100, 110, 125, 138, 150, 175, 200, 225, 250.
HYP16B0(Rate)UHT.....\$75.91



Street Stocks/Stock Appearing

11" x 5-1/2" Rear (1 End Pigtail/1 End Closed)

Rates: 150, 175, 200, 225, 250, 275, 300.
HYP18SNP11-(Rate).....\$47.86

12" x 5-1/2" Rear (1 End Pigtail/1 End Closed)

Rates: 150, 175, 200, 225, 250, 275, 300.
HYP18SNP12-(Rate).....\$47.86

14" x 7" Rear (Double Pigtail Ends)

Rates: 175, 200, 225, 250, 300.
HYP18SDP-(Rate).....\$47.86

5-1/2" x 11" Front (1 End Open/1 End Closed & Ground)

Rates: 800, 900, 1000, 1100, 1200, 1300.
HYP18Z(Rate)-11.....\$61.11

5-1/2" x 12" Front (1 End Open/1 End Closed & Ground)

Rates: 800, 900, 1000, 1100, 1200, 1300, 1400, 1500.
HYP18Z(Rate)-12.....\$61.11

1-7/8" x 10"

Rates: 050, 062, 075, 087, 095, 100, 112, 125, 137, 150, 162, 175, 185, 200, 225, 250, 275, 300, 325, 350, 375, 400, 425, 450, 475, 500, 525, 550, 600.
HYP1810D(Rate).....\$64.82

5" x 9-1/2"

Rates: 450, 500, 550, 600, 650, 700, 750, 800, 850, 900, 950, 1000, 1050, 1100, 1150, 1250, 1370, 1490.
HYP18Y(Rate).....\$47.86

5" x 11"

Rates: 125, 150, 175, 200, 225, 275, 300, 325, 350, 375.
HYP18SN-(Rate).....\$47.86

5" x 13"

Rates: 100, 125, 150, 165, 175, 185, 200, 250, 275, 300, 325, 350, 375.
HYP18S-(Rate).....\$47.86

5" x 15"

Rates: 125, 150, 175, 200, 225, 250.
HYP18SNS-(Rate).....\$61.11

5" x 16"

Rates: 125, 150, 175, 200, 225, 250.
HYP18SNU-(Rate).....\$66.57

5" x 20"

Rates: 100, 125, 150.
HYP18SNT-(Rate).....\$86.84

5-1/2" x 9-1/2"

Rates: 500, 550, 600, 650, 700, 750, 800, 850, 900, 950, 1000, 1050, 1100, 1200, 1320, 1440.
HYP18Z(Rate).....\$47.86

Helper Spring

4" FI, 2.5" Dia.....HYPCS100.....\$24.93
6" FI, 2.5" Dia.....HYPCS600.....\$24.93

Coil Over Take Up Spring Divider

HYP18DS100...\$45.62



Longacre

1-1/4" Large Spacing Coil Over Spring Rubbers

With these new spring rubbers, you can now fill that larger gap between coils to fine tune your set-up! Fine tune your spring rate for the perfect setup. Make quick adjustments during practice or on pit stops. Used by virtually all Sprint Cup teams in every race.

Orange - Soft Spring Rubber.....LON61016.....\$41.88
Red - Medium Spring Rubber.....LON61041.....\$41.88
Blue - Hard Spring Rubber.....LON61051.....\$41.88

Longacre

Coil Over Spring Rubbers

Yellow 5 Soft.....LON61005.....\$37.17
Clear 10.....LON61010.....\$37.17
Orange 15.....LON61015.....\$37.17
Red 40.....LON61040.....\$37.17
Blue 50.....LON61050.....\$37.17
Black 70 Hard.....LON61070.....\$37.17

5/5.5" Deep Groove Spring Rubber
Red Soft.....LON61140.....\$55.84
Blue Medium.....LON61150.....\$55.84
Black Hard.....LON61170.....\$55.84

2-1/2" x 8"

Rates: 150, 175, 200, 225, 250, 275, 300, 325, 350, 375, 400, 425, 450, 475, 500, 525, 550, 600, 650, 700, 750, 800, 850, 900, 950, 1000, 1050, 1100, 1200.
EIB0800-250-(Rate).....\$65.00

2-1/2" x 10"

Rates: 100, 150, 162, 175, 200, 225, 250, 275, 300, 325, 350, 375, 400, 425, 450, 500, 550, 600, 650, 700, 750, 800.
EIB1000-250-(Rate).....\$65.00

2-1/2" x 12"

Rates: 080, 090, 100, 110, 120, 125, 130, 140, 150, 165, 175, 185, 200, 225, 250, 275, 300, 325, 350, 375, 400, 425, 450, 500, 525, 550, 600, 625, 650, 700, 750, 800, 900, 1000.
EIB1200-250-(Rate).....\$70.00

2-1/2" x 14"

Rates: 080, 090, 100, 110, 120, 125, 130, 140, 150, 165, 175, 185, 200, 225, 250, 275, 300, 350, 400, 450, 475, 500, 550, 600, 650.
EIB1400-250-(Rate).....\$70.00

1-7/8" x 8"

Rates: 100, 125, 150, 175, 185, 200, 225, 250, 275, 300, 325, 350.
EIB0800-188-(Rate).....\$60.00

1-7/8" x 10"

Rates: 050, 060, 070, 080, 090, 100, 115, 130, 145, 160, 175, 200, 225, 250, 275, 300, 325, 350, 375, 400, 425, 450, 475, 500.
EIB1000-188-(Rate).....\$60.00

1-5/8" x 5"

Rates: 070, 075, 080, 090, 095, 100, 105, 110, 115, 120, 125, 130, 135, 140, 145, 150, 155, 160.
EIB0500-163-0(Rate).....\$26.00

2-1/4" x 8"

Rates: 150, 185, 200, 225, 250, 275, 300, 325, 350, 375, 400, 425, 450, 475, 500, 525, 550, 575, 600, 650, 675, 700, 750, 800, 850, 900, 950, 1000.
EIB0800-225-0(Rate).....\$70.00

5" x 9-1/2"

Rates: 450, 500, 550, 600, 700, 750, 800, 850, 900, 950, 1000, 1050, 1100, 1200, 1250, 1300, 1400, 1500, 1600.
EIB0950-500-(Rate).....\$65.00

5" x 11"

Rates: 125, 150, 175, 200, 225, 250, 275, 300, 325, 350, 375, 400, 425, 450, 500, 550, 600, 650, 700.
EIB1100-500-(Rate).....\$65.00

5" x 13"

Rates: 125, 150, 175, 200, 225, 250, 275, 300, 325, 350, 375, 400, 425, 450, 500, 550, 600, 650, 700.
EIB1300-500-(Rate).....\$65.00

2-1/2" x 8" Barrel Springs

Rates: 225, 250, 275, 300, 350, 400, 450, 500, 550, 600, 650, 700..
EIB0800-2530-(Rate).....\$80.00

2-1/2" x 10" Barrel Springs

Rates: 225, 250, 275, 300, 325, 350, 375, 400, 425, 450, 475, 500, 525, 550, 575, 600.
EIB1000-2530-(Rate).....\$80.00

2-1/2" x 12" Barrel Springs

Rates: 100, 125, 150, 165, 175, 185, 200, 225, 250, 275, 300, 325, 350, 375, 400, 425, 650.
EIB1200-2530-(Rate).....\$90.00

2-1/2" x 14" Barrel Springs

Rates: 100, 125, 150, 175, 185, 200, 225, 250, 275, 300.
EIB1400-2530-(Rate).....\$90.00

2-1/2" x 16" Barrel Springs

Rates: 100, 125, 150, 175, 200, 225, 250.
EIB1600-2530-(Rate).....\$90.00



Eibach Springs

Eibach makes the finest performance springs in the world. Period. When other springs sag, wear out, or create sketchy handling or a bone-crushing ride, top street tuners—like top race teams, from F1 to WRC, from Le Mans to NASCAR—inevitably turn to Eibach. And, also inevitably, wonder why they didn't choose Eibach in the first place.

- Tolerances—The Tightest in the Industry
- Every Spring, Anti-Roll Bar and Damper Kit Extensively Developed and Road Tested for Maximum Performance
- Street Kits Designed for the Best Performance, the Best Look—and the Best Ride.
- Ultra-Lightweight, for Reduced Unsprung Mass
- Exceptional Block Resistance and Durability

Eibach uses the exact same technology in our street springs as we do in our legendary race springs. We use the world's finest Hi-Ten spring steel, produced to exceedingly precise tolerances. We use world-renowned German CNC coilers, as well as many unique machines engineered and built specifically by Eibach—simply state-of-the-art technology, in every step of the manufacturing process. But it's not just about machines and technology: it's about people. Most notably, the Eibach Springmeisters, working at production plants in Germany and the USA: Talented, expert craftsmen, each committed to creating the finest race—and street-Performance—springs in the world.

5-1/2" x 9-1/2"

Rates: 400, 450, 500, 550, 600, 650, 700, 750, 800, 850, 900, 950, 1000, 1100, 1200, 1300, 1400, 1500.
EIB0950-550-(Rate).....\$65.00

2.25" x 1.36" I.D. Bump Spring

Rates: 200, 350, 450, 550, 650, 750, 850, 950, 1000, 1250.
EIB0225-1400.....\$85.00

2" x 2-1/2" Bump Springs

Rates: 350, 400, 450, 550, 650, 750, 850, 950, 1050, 1250, 1400, 1500, 1600, 1750, 2000, 2500, 3000, 3500, 4000, 4500, 5000, 7500.
EIB0225-200-(Rate).....\$85.00

Helper 250

Free Length 3.00
EIBHELPER188.....\$45.00
EIBHELPER225.....\$45.00
EIBHELPER250.....\$45.00

Spring Rubbers

60D Purple..EIBSR-2530-0060 \$40.00
70D Green..EIBSR-2530-0070 \$40.00
80D Yellow..EIBSR-2530-0080 \$40.00
90D Blue.....EIBSR-2530-0090 \$40.00

Spacers

2.25" Spacer..EIBSPACER225 \$25.00
2.50" Spacer..EIBSPACER250 \$25.00

Bump Spring Cap

.500 CapEIBBSC-500.....\$35.00
.625 CapEIBBSC-625.....\$35.00
.875 CapEIBBSC-875.....\$35.00

Torsion Release Bearing

Reduce torsional binding by using Eibach torsion release bearings.
2.25" ..EIBTRB225 \$40.00
2.50" ..EIBTRB250 \$40.00

SG Series



Designed for, but is not limited to, Stock Cars, IMCA/UMP Modifieds, Midgets, Mini-Sprints, Modified Lites, and Dwarf Cars. 36mm (1.42") diameter steel, sealed monotube gas pressure shock.

- Converts to coilover applications
- Economy price
- Lightweight
- Low rod pressure
- Bilstein's famous consistent, fade-free performance

Available in 6", 7" and 8" strokes:

Model	Extended Length	Collapsed Length	
S6G	17.00"	11.00"	\$114.33
S7G	20.00"	12.00"	\$79.20



Some Valvings have an Additional Charge!

Available in these standard valvings:
 2020 3010 1030 3030 3020 2040
 3535 4010 3050 4040 4020 3060
 4545 5030 1090 5050 6020**
 5555 6035* 6565 7035* 8035* 9010
 *Built w/RBT piston for strong "tie down" characteristics
 **High bleed valving designed for rear

Short Track Shock List Digressive Valvings

7 Inch: Comp: 13.14" • Ext: 20"

BILS7Z(Rebound)(Compression) \$114.73

BILS7Z-1090	BILS7Z-2040	BILS7Z-3030	BILS7Z-3040
BILS7Z-3050	BILS7Z-3060	BILS7Z-3540	BILS7Z-3545
BILS7Z-4010	BILS7Z-4040	BILS7Z-4555	BILS7Z-5030
BILS7Z-5040	BILS7Z-5050	BILS7Z-5555	BILS7Z-5570
BILS7Z-6010	BILS7Z-6040	BILS7Z-6060	BILS7Z-6065
BILS7Z-6070	BILS7Z-7030	BILS7Z-7045	BILS7Z-7060
BILS7Z-8040	BILS7Z-8060		

9 Inch: Comp: 23.44" • Ext: 23.44"

BILS9Z(Rebound)(Compression) \$121.48

BILS9Z-3030	BILS9Z-3040	BILS9Z-3050	BILS9Z-3060
BILS9Z-3530	BILS9Z-3545	BILS9Z-4010	BILS9Z-4040
BILS9Z-4555	BILS9Z-5030	BILS9Z-5040	BILS9Z-5050
BILS9Z-5555	BILS9Z-6010	BILS9Z-6040	BILS9Z-6060
BILS9Z-7030	BILS9Z-7045	BILS9Z-7060	

Short Track Shock List Linear Valvings

7 Inch: Comp: 13.14" • Ext: 20" • Travel 6.86"

BILB46-0210A	230/78	\$121.48
BILB46-0210B	208/72	\$121.48
BILB46-0210C	162/55	\$121.48
BILB46-0210D	220/120	\$121.48
BILB46-0210H	300/100	\$121.48
BILB46-0210L	180/90	\$121.48
BILB46-0210R	180/120	\$121.48
BILB46-0210-180-100	180/100	\$145.52
BILB46-0210-208-55	208/55	\$145.52

9 Inch: Comp: 14.94" • Ext: 23.44" • Travel 8.5"

BILB46-0207A	230/78	\$121.48
BILB46-0207B	208/72	\$121.48
BILB46-0207C	162/55	\$139.95
BILB46-0207S	230/100	\$111.75
BILB46-0207-162-72	162/72	\$145.52
BILB46-0207-200-180	200/180	\$145.52
BILB46-0207-208-100	208/100	\$145.52
BILB46-0207-208-90	208/90	\$145.52
BILB46-0207-230-55	230/55	\$145.52
BILB46-0207-230-72	230/72	\$145.52
BILB46-0207-230-90	230/90	\$145.52
BILB46-0207-270-120	270/120	\$145.52



Spring Bags

Keep The Dirt Out. LW Material. Eliminates Mud Packing Inside Coils. Keeps Spring Adjuster & Damper Shaft Clean-Extends Damper Life. Reinforced Wear Bars for Long Life. Washable Material.

(Fits 2.50" I.D.) Spring Length: 12" - 14"	EIBESB14-250	\$40.00
(Fits 3.00" I.D.) Spring Length: 10" - 12"	EIBESB12-300	\$40.00
(Fits 3.00" I.D.) Spring Length: 12" - 14"	EIBESB14-300	\$40.00
(Fits 3.00" I.D.) Spring Length: 14" - 16"	EIBESB16-300	\$40.00



Shockwears

For Late Model/Modifieds

Diameter Std 3-1/2" • Length 14"

Black	OUT30-2445-01	\$37.95
Blue	OUT30-2445-02	\$37.95
Red	OUT30-2445-03	\$37.95

For Northeast Modifieds

Diameter Std 3" • Length 14"

Black	OUT30-1165-01	\$34.45
Blue	OUT30-1165-02	\$34.45
Red	OUT30-1165-03	\$34.45

For Micro Mini Sprint

Diameter Std 3-1/2" • Length 10-1/2"

Black	OUT30-1047-01	\$34.45
Blue	OUT30-1047-02	\$34.45
Red	OUT30-1047-03	\$34.45
Yellow	OUT30-1047-04	\$34.45

Large Shockwear NEW

Diameter Std 4-1/4" • Length 20"

Black	OUT30-3177-01	\$37.95
-------	---------------	---------



Armor Shockwears

Armor Shockwears are manufactured with a flexible armor plated material that is designed to take abuse. Sand and dirt act like sandpaper against the seals and shock shaft. Armor Shockwears reduce the amount of dirt and debris that wear down your shafts and seals, providing you with reduced maintenance and prolonged shock life. A Velcro® closure makes installation easy and eliminates the need to remove the shocks. It is also vented to allow for cooling air transfer during use.

21" Long	OUT32-2605-01	\$35.43
14" Long	OUT32-2612-01	\$35.43
12" Long	OUT32-2682-01	\$35.43

Bilstein Replacement Shock Parts



Rod Guide

1 pc. 46mm Rod Guide Grooved
BILB4-BOA-0000119\$24.36

Hex Nylock Nut

M 8x1 Hex Nylock Nut (piston rod)
BIL1000424\$0.65

46mm Linear Piston

(8mm Bore)
BILE4-B46-20SNCT\$33.23

46mm Teflon Piston Band

BILE4-KR2-X001A02\$2.03

Coil Over Kit

ASN Series CompleteBILB4-BOA-0000190\$69.00
46mm slide-on coilover kitBILB4-BOA-0000117\$62.59
36mm slide-on coilover kitBILB4-BOA-0000187\$43.83
36mm aluminum coilover kitBILB4-BOA-0000257\$



Shock Bare Tubes

7 SZ Tube (bare)
BILB4-RK2-Z102A51\$35.15

9 SZ Tube (bare)
BILB4-RK2-Z102A52\$35.15

Non Adjustable Piston Rods

7" ...BILE4-KS2-Z060A00 ..\$35.77

9" ...BILE4-KS2-Z060A19 ..\$35.77

Schrader Valve

BILB4-XD0-Z006A01...\$3.49



46mm Gas Fill Tool

BILB4-KT0-Z021A00\$

Disassembly collar

BILB4-LG0-Z043A01\$35.77



4 Piece Pick Set MST-3040

BIL193040.....\$20.88



Shock Oil (Gallon)

BIL193031.....\$33.50



STREET STOCK AK SERIES



AK Series

AK - 36mm/46mm stock sealed steel 36mm/46mm diameter sealed steel body stock mount shocks and struts.

The product benefits at a glance: Monotube gas pressure construction. For Camaro, Chevelle, Monte Carlo/Buick Regal, Full-size Ford, and Mustang bodies. Available Race Shock Kit Packages include 7 AK Series shocks, instructions and recommended set-ups for dialing in your car. Applications: Pure stock, Enduro, Street Stock (stock mount), Mini-Stock.

Camaro

Year	Front Part #	Rear Part #
70-76	BILAK2072\$64.27	BILAK1054\$80.73
77-81	BILAK1053\$64.27	BILAK1054\$80.73
82-92		BILAK1050\$80.73

Chevelle

Year	Front Part #	Rear Part #
73-83	BILAK1043\$64.27	BILAK1044\$64.27
73-83	BILAK1051\$64.27	BILAK1052\$80.73
73-83	BILAK3050F...\$76.02	BILAK3030R.....\$76.02
73-83	BILAK4040F...\$76.02	BILAK3030R.....\$76.02

Monte Carlo-Buick Regal

Year	Front Part #	Rear Part #
73-88	BILAK1043.....\$64.27	BILAK1044\$64.27

Full Size Ford

Year	Front Part #	Rear Part #
79-93	BILAK1195.....\$80.73	BILAK1196.....\$80.73

Linear Valving Kit

(2 boxes)
BILB4-BOA-0000149\$368.08

Digressive Valving Kit

(2 boxes)
BILB4-BOA-0000150\$368.08

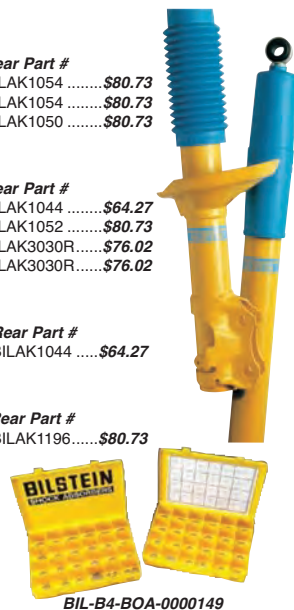

14mm steel assembly needle.....BILE4-BOA-0000560 ..\$14.73
Bump CapBILE4-SB3-Z004A02 ..\$9.74

Dirt Modified Shocks



Integra Front Standard
KEY310-40170\$369.59

Left Front

BD1 Digressive 7 Inch
KEY310-40170-LF-BD1.....\$369.59

Standard with plus 1 rebound
KEY310-40170-LF-STD+1REB\$369.93

Right Front

BD1 Digressive 7 Inch
KEY310-40170-RF-BD1\$369.59

Standard with plus 2 rebound
KEY310-40170-RF-STD+2REB\$369.93

Left Rear

Medium Linear 9 Inch
KEY310-40190L-MED\$369.59

Rachel Digressive 9 Inch
KEY310-40190L-RACHEL\$369.59

Short Rod Shocks
KEY310-40190-LR-RSR.....\$369.96

9 Inch Alum. Stealth Traction
KEY310-40190-LR-TRACTION\$369.59

Right Rear

3 Port Piston 9 Inch
KEY310-40190R-3PORT.....\$430.71

Right Rear Medium Linear 9 Inch
KEY310-40190R-MED\$369.59

Right Rear Short Rod Shock
KEY310-40190-RR-RSR\$369.96

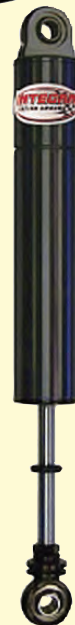

Integra Coil Kit

BRP9052.....\$43.47





For over three decades, Fox has been an industry leader in the design and development of high performance shock absorbers and racing suspension products for snowmobiles, mountain bikes, motorcycles, ATVs, UTVs, off-road cars, trucks, and SUVs.

In 1974, Bob Fox started racing his products in motocross and we haven't stopped racing since. Fox equipped vehicles and racers have stood atop podiums in every sport we have competed in — from the sands of Baja to the dunes of Dakar. Our team of engineers perform rigorous tests with our athletes year round. The data we collect from performance testing and our application of that knowledge to our product is what separates Fox from every other suspension company.

**Call about our DIRT Legal Shocks!
We don't have DIRT Stickers.**

2.0 Steel Shock

Body: Smooth-bore, clear coated, zinc plated, honed seamless alloy bodies.

Components: Black anodized 6061-T6 billet aluminum.

Shaft: 1/2" hard chrome plated heat treated alloy steel.

Piston: Race-developed Linear and Digressive piston design.

Seals: Redundant sealing pack system main seal, wiper seal, scraper seal.

Oil: Specially formulated for ultimate performance at variable temperatures.

Mounting: 1/2" spherical bearing.

Maintenance: 100% racer rebuild able.



7" Steel Shock

60C/165R	Linear Track -Steel 7.1 Trav 1.25C-4R 20.1 Ext.....	FOX983-91-507-10 ...	\$175.00
60C/200R	Linear Track -Steel 7.1 Trav 1.25C-5R 20.1 Ext.....	FOX983-91-507-11 ...	\$175.00
75C/165R	Linear Track -Steel 7.1 Trav 1.5C-4R 20.1 Ext.....	FOX983-91-507-12 ...	\$175.00
75C/200R	Linear Track -Steel 7.1 Trav 1.5C-5R 20.1 Ext.....	FOX983-91-507-13 ...	\$175.00
75C/230R	Linear Track -Steel 7.1 Trav 1.5C-5.5R 20.1 Ext.....	FOX983-91-507-14 ...	\$175.00
70C/200R-D	Digressive Track -Steel 7.1 Trav FLFT 20.1 Ext.....	FOX983-91-507-50 ...	\$195.00
85C/175R-D	Digressive Track -Steel 7.1 Trav FRFT 20.1 Ext.....	FOX983-91-507-51 ...	\$195.00

9" Steel Shock

75C/200R	Linear Track -Steel 8.9 Trav 1.5C-5R 23.5 Ext.....	FOX983-91-509-13 ...	\$175.00
75C/230R	Linear Track -Steel 8.9 Trav 1.5C-5.5R 23.5 Ext.....	FOX983-91-509-14 ...	\$175.00
115C/165R	Linear Track -Steel 8.9 Trav 2.75C-4R 23.5 Ext.....	FOX983-91-509-15 ...	\$175.00
115C/200R	Linear Track -Steel 8.9 Trav 2.75C-5R 23.5 Ext.....	FOX983-91-509-16 ...	\$175.00
115C/230R	Linear Track -Steel 8.9 Trav 2.75C-5.5R 23.5 Ext.....	FOX983-91-509-18 ...	\$175.00
145C/145R-D	Digressive Track -Steel 8.9 Trav FLRT 23.5 Ext.....	FOX983-91-509-52 ...	\$195.00
100C/200R-D	Digressive Track -Steel 8.9 Trav FRRT 23.5 Ext.....	FOX983-91-509-53 ...	\$195.00

2.0 Bulb Shock

Body: Threaded Aluminum shock body dissipates heat three times faster than steel.

Bulb: Large Nitrogen chamber to reduce gas pressure ramp.

Base Valve: Ability to run lower gas pressure, Racer tunable.

Components: Black anodized 6061-T6 billet alum.

Shaft: 1/2" hard chrome plated heat treated alloy steel.

Piston: Race-developed Linear and Digressive piston design.

Seals: Redundant sealing pack system main seal, wiper seal, scraper seal.

Oil: Specially formulated for ultimate performance at variable temperatures.

Mounting: 1/2" spherical bearing.

Maintenance: 100% racer rebuild able



7" Aluminum Bulb Shock

60C/165R	Linear Track -Bulb 7.3 Trav Base 1.25C-4R 21.9 Ext.....	FOX983-90-007-10 ...	\$329.95
60C/200R	Linear Track -Bulb 7.3 Trav Base 1.25C-5R 21.9 Ext.....	FOX983-90-007-11 ...	\$329.95
75C/165R	Linear Track -Bulb 7.3 Trav Base 1.5C-4R 21.9 Ext.....	FOX983-90-007-12 ...	\$329.95
75C/200R	Linear Track -Bulb 7.3 Trav Base 1.5C-5R 21.9 Ext.....	FOX983-90-007-13 ...	\$329.95
75C/230R	Linear Track -Bulb 7.3 Trav Base 1.5C-5.5R 21.9 Ext.....	FOX983-90-007-14 ...	\$329.95
60C/230R	Linear Track -Bulb 7.3 Trav Base 1.25C-5.5R 21.9 Ext.....	FOX983-90-007-17 ...	\$329.95
70C/200R-D	Digressive Track -Bulb 7.3 Trav Base FLFT 21.9 Ext.....	FOX983-90-007-50 ...	\$349.95
85C/175R-D	Digressive Track -Bulb 7.3 Trav Base FRFT 85C/175R-D 21.9 Ext.....	FOX983-90-007-51 ...	\$349.95

9" Aluminum Bulb Shock

75C/200R	Linear Track -Bulb 9.1 Trav Base 1.5C-5R 25.3 Ext.....	FOX983-90-009-13 ...	\$329.95
75C/230R	Linear Track -Bulb 9.1 Trav Base 1.5C-5.5R 25.3 Ext.....	FOX983-90-009-14 ...	\$329.95
115C/165R	Linear Track -Bulb 9.1 Trav Base 2.75C-4R 25.3 Ext.....	FOX983-90-009-15 ...	\$329.95
115C/200R	Linear Track -Bulb 9.1 Trav Base 2.75C-5R 25.3 Ext.....	FOX983-90-009-16 ...	\$329.95
115C/230R	Linear Track -Bulb 9.1 Trav Base 2.75C-5.5R 25.3 Ext.....	FOX983-90-009-18 ...	\$329.95
145C/145R-D	Digressive Track -Bulb 9.1 Trav Base FLRT 25.3 Ext.....	FOX983-90-009-52 ...	\$349.95
100C/200R-D	Digressive Track -Bulb 9.1 Trav Base FRRT 25.3 Ext.....	FOX983-90-009-53 ...	\$349.95



Coil Over Kit 2.0" Track

Coil Over Sleeve w/Hardware

FOX803-02-062.....**\$67.95**



Coil Over Kit 2.5"

Track Coil Over Sleeve w/Hardware

FOX803-02-047.....**\$45.95**



Body Cap Bulb

Body Cap: 2.250 Bore, 4.615 TLG, 7/16 UNF Angles Port, -8 Heim Aluminum
FOX206-06-127.....**\$65.57**



Spring Seat

Coil Over Hat

FOX234-00-461.....**\$27.16**



JM92 Advanced Suspension Fluid

Engineered to perform at high temps formulated using advanced base fluids to provide consistent and predictable suspension performance at temps ranging from -70° to a scorching 400°. Gallon..FOX025-03-012..**\$59.00**



Schrader Valve w/ O'Ring

FOX010-00-021.....**\$4.79**



Nitrogen Filler Gauge

The same gauge FOX technicians use to properly read reservoir nitrogen levels without sustaining pressure loss from 0 to 600 psi.

0-600psi Schrader Style Nitrogen Filler Gauge

FOX802-02-002-A.....**\$76.95**



Spring Guide Nylon

FOX234-00-010-B.....**\$19.95**



Valve Shim Kit

Complete kit of proprietary deburred valve shims for 2.0, 2.5, 3.0, and 3.5 shocks. Includes 10 shims in every available size.
FOX803-01-024.....**\$289.95**

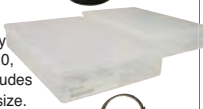

Kit: Bearing Cap Removal 1 8-3/4" Bore

FOX803-00-668.....**\$39.99**



Base Valve Spanner Wrench

Black anodized aluminum spanner wrench with stainless steel pin facilitates removal of the base valve from the shock body.
FOX803-00-766....**\$42.00**



Shaft Clamp

Billet aluminum shaft clamp assists in the removal of eyelets from 1/2" and 5/8" shafts.
FOX803-00-895....**\$82.28**



Bump Stop

FOX008-02-005.....**\$5.40**



Service Set Bearing Assembly all without threads

FOX812-07-067-KIT**\$20.16**



Bump Cap Assembly Kit

FOX812-11-036KIT**\$25.20**



Service Set Eyelet Assy Eyelet Shaft

FOX808-21-010-KIT**\$44.69**



Piston Digressive

FOX222-01-249**\$43.20**



Piston, Linear Bleed

FOX222-07-001-A.....**\$19.80**



Piston, Linear No Bleed

FOX222-07-002-A.....**\$19.80**



Piston, Linear 1 x .070 Bleed

FOX222-07-007-A.....**\$19.80**



Seal Saver/ Bullet for 1/2 Rod

FOX398-00-026-B.....**\$12.50**





2.0 Steel Shock

Body: Smooth-bore, clear coated, zinc plated, honed seamless alloy bodies.

Components: Black Anodized 6061-T6 billet aluminum.

Shaft: 1/2" hard chrome plated heat treated alloy steel.

Piston: Race-developed Linear and Digressive piston design.

Seals: Redundant sealing pack system main seal, wiper seal, scraper seal.

Oil: Specially formulated for ultimate performance at variable temps.

Mounting: 1/2" spherical bearing.

Maintenance: 100% racer rebuild able.

6.5" Steel Bulb Shock - Shrader Valve

100C/300R	2.5C-7R, 20.3" Ext	FOX983-93-007-25	\$331.95
125C/165R	3C-4R, 20.3" Ext	FOX983-93-007-28	\$331.95
125C/200R	3C-5R, 20.3" Ext	FOX983-93-007-29	\$331.95
125C/230R	3C-5.5R, 20.3" Ext	FOX983-93-007-30	\$331.95
100C/350R-D	2.5C-8R-D, 20.3" Ext	FOX983-93-007-57	\$331.95
100C/400R-D	2.5C-9R-D, 20.3" Ext	FOX983-93-007-58	\$331.95
100C/470R-D	2.5C-10R-D, 20.3" Ext	FOX983-93-007-59	\$331.95
100C/550R-D	2.5C-11R-D, 20.3" Ext	FOX983-93-007-60	\$331.95
100C/625R-D	2.5C-12R-D, 20.3" Ext	FOX983-93-007-61	\$331.95
125C/350R-D	3C-8R-D, 20.3" Ext	FOX983-93-007-62	\$331.95
125C/400R-D	3C-9R-D, 20.3" Ext	FOX983-93-007-63	\$331.95
125C/470R-D	3C-10R-D, 20.3" Ext	FOX983-93-007-64	\$331.95
125C/550R-D	3C-11R-D, 20.3" Ext	FOX983-93-007-65	\$331.95
125C/625R-D	3C-12R-D, 20.3" Ext	FOX983-93-007-66	\$331.95

6.5" Steel Bulb Shock - IMCA Fill Valve

100C/300R	2.5C-7R, 20.3" Ext, Seal Screw	FOX983-93-037-25	\$331.95
125C/165R	3C-4R, 20.3" Ext, Seal Screw	FOX983-93-037-28	\$331.95
125C/200R	3C-5R, 20.3" Ext, Seal Screw	FOX983-93-037-29	\$331.95
125C/230R	3C-5.5R, 20.3" Ext, Seal Screw	FOX983-93-037-30	\$331.95
100C/350R-D	2.5C-8R-D, 20.3" Ext, Seal Screw	FOX983-93-037-57	\$331.95
100C/400R-D	2.5C-9R-D, 20.3" Ext, Seal Screw	FOX983-93-037-58	\$331.95
100C/470R-D	2.5C-10R-D, 20.3" Ext, Seal Screw	FOX983-93-037-59	\$331.95
100C/550R-D	2.5C-11R-D, 20.3" Ext, Seal Screw	FOX983-93-037-60	\$331.95
100C/625R-D	2.5C-12R-D, 20.3" Ext, Seal Screw	FOX983-93-037-61	\$331.95
125C/350R-D	3C-8R-D, 20.3" Ext, Seal Screw	FOX983-93-037-62	\$331.95
125C/400R-D	3C-9R-D, 20.3" Ext, Seal Screw	FOX983-93-037-63	\$331.95
125C/470R-D	3C-10R-D, 20.3" Ext, Seal Screw	FOX983-93-037-64	\$331.95
125C/550R-D	3C-11R-D, 20.3" Ext	FOX983-93-037-65	\$331.95
125C/625R-D	3C-12R-D, 20.3" Ext	FOX983-93-037-66	\$331.95

8.4" Steel Bulb Shock - Shrader Valve

75C/200R	1.5C-5R, 24.0" Ext	FOX983-93-009-13	\$331.95
75C/230R	1.5C-5.5R, 24.0" Ext	FOX983-93-009-14	\$331.95
115C/200R	2.75C-5R, 24.0" Ext	FOX983-93-009-16	\$331.95
115C/230R	2.75C-5.5R, 24.0" Ext	FOX983-93-009-18	\$331.95
100C/200R	2.75C-8R, 24.0" Ext	FOX983-93-009-27	\$331.95
100C/200R-M	2.75C-5R-M, 24.0" Ext	FOX983-93-009-31	\$331.95
275C/175R-M	6.5C-4.5R-M, 24.0" Ext	FOX983-93-009-32	\$331.95
325C/175R-M	7.5C-4.5R-M, 24.0" Ext	FOX983-93-009-33	\$331.95
375C/175R-M	8C-4.5R-M, 24.0" Ext	FOX983-93-009-34	\$331.95
400C/175R-M	9C-4.5R-M, 24.0" Ext	FOX983-93-009-35	\$331.95
275C/150R-M	6.5C-3R-M, 24.0" Ext	FOX983-93-009-36	\$331.95
325C/150R-M	7C-3R-M, 24.0" Ext	FOX983-93-009-37	\$331.95
375C/150R-M	8C-3R-M, 24.0" Ext	FOX983-93-009-38	\$331.95
400C/150R-M	9C-3R-M, 24.0" Ext	FOX983-93-009-39	\$331.95
100C/200R-D	FRRT, 24.0" Ext	FOX983-93-009-53	\$331.95
400C/100R-D	9C-2.5R-D, 24.0" Ext	FOX983-93-009-67	\$331.95
470C/100R-D	10C-2.5R-D, 24.0" Ext	FOX983-93-009-68	\$331.95
550C/100R-D	11C-2.5R-D, 24.0" Ext	FOX983-93-009-69	\$331.95

8.4" Steel Bulb Shock - IMCA Valve

1.5C/5R	1.5C-5R, 24.0" Ext, Seal Screw	FOX983-93-039-13	\$331.95
75C/230R	1.5C-5.5R, 24.0" Ext, Seal Screw	FOX983-93-039-14	\$331.95
115C/200R	2.75C-5R, 24.0" Ext, Seal Screw	FOX983-93-039-16	\$331.95
115C/230R	2.75C-5.5R, 24.0" Ext, Seal Screw	FOX983-93-039-18	\$331.95
100C/200R	2.5C-8R, 24.0" Ext, Seal Screw	FOX983-93-039-27	\$331.95
100C/200R-M	2.5C-5R-M, 24.0" Ext, Seal Screw	FOX983-93-039-31	\$331.95
275C/175R-M	6.5C-4.5R-M, 24.0" Ext, Seal Scr	FOX983-93-039-32	\$331.95
325C/175R-M	7.5C-4.5R-M, 24.0" Ext, Seal Scr	FOX983-93-039-33	\$331.95
375C/175R-M	8C-4.5R-M, 24.0" Ext, Seal Screw	FOX983-93-039-34	\$331.95
400C/175R-M	9C-4.5R-M, 24.0" Ext, Seal Screw	FOX983-93-039-35	\$331.95
275C/150R-M	6.5C-3R-M, 24.0" Ext, Seal Screw	FOX983-93-039-36	\$331.95
325C/150R-M	7C-3R-M, 24.0" Ext, Seal Screw	FOX983-93-039-37	\$331.95
375C/150R-M	8C-3R-M, 24.0" Ext, Seal Screw	FOX983-93-039-38	\$331.95
400C/150R-M	9C-3R-M, 24.0" Ext, Seal Screw	FOX983-93-039-39	\$331.95
100C/200R-D	FRRT, 24.0" Ext, Seal Screw	FOX983-93-039-53	\$331.95
400C/100R-D	9C-2.5R-D, 24.0" Ext, Seal Screw	FOX983-93-039-67	\$331.95
470C/100R-D	10C-2.5R-D, 24.0" Ext, Seal Screw	FOX983-93-039-68	\$331.95
550C/100R-D	11C-2.5R-D, 24.0" Ext, Seal Screw	FOX983-93-039-69	\$331.95

7.2" Track All Steel Shock - Shrader Valve

100C/300R	2.5C-7R, 20.4" Ext	FOX983-95-507-25	\$249.00
125C/165R	3C-4R, 20.4" Ext	FOX983-95-507-28	\$249.00
125C/200R	3C-5R, 20.4" Ext	FOX983-95-507-29	\$249.00
125C/230R	3C-5.5R, 20.4" Ext	FOX983-95-507-30	\$249.00
100C/350R-D	2.5C-8R-D, 20.4" Ext	FOX983-95-507-57	\$249.00
100C/400R-D	2.5C-9R-D, 20.4" Ext	FOX983-95-507-58	\$249.00
100C/470R-D	2.5C-10R-D, 20.4" Ext	FOX983-95-507-59	\$249.00
100C/550R-D	2.5C-11R-D, 20.4" Ext	FOX983-95-507-60	\$249.00
100C/625R-D	2.5C-12R-D, 20.4" Ext	FOX983-95-507-61	\$249.00
125C/350R-D	3C-8R-D, 20.4" Ext	FOX983-95-507-62	\$249.00
125C/400R-D	3C-9R-D, 20.4" Ext	FOX983-95-507-63	\$249.00
125C/470R-D	3C-10R-D, 20.4" Ext	FOX983-95-507-64	\$249.00
125C/550R-D	3C-11R-D, 20.4" Ext	FOX983-95-507-65	\$249.00
125C/625R-D	3C-12R-D, 20.4" Ext	FOX983-95-507-66	\$249.00

7.2" Track All Steel Shock - IMCA Fill Valve

100C/300R	2.5C-7R, 20.4" Ext, Seal Screw	FOX983-95-537-25	\$249.00
125C/165R	3C-4R, 20.4" Ext, Seal Screw	FOX983-95-537-28	\$249.00
125C/200R	3C-5R, 20.4" Ext, Seal Screw	FOX983-95-537-29	\$249.00
125C/230R	3C-5.5R, 20.4" Ext, Seal Screw	FOX983-95-537-30	\$249.00
100C/350R-D	2.5C-8R-D, 20.4" Ext, Seal Screw	FOX983-95-537-57	\$249.00
100C/400R-D	2.5C-9R-D, 20.4" Ext, Seal Screw	FOX983-95-537-58	\$249.00
100C/470R-D	2.5C-10R-D, 20.4" Ext, Seal Screw	FOX983-95-537-59	\$249.00
100C/550R-D	2.5C-11R-D, 20.4" Ext, Seal Screw	FOX983-95-537-60	\$249.00
100C/625R-D	2.5C-12R-D, 20.4" Ext, Seal Screw	FOX983-95-537-61	\$249.00
125C/350R-D	3C-8R-D, 20.4" Ext, Seal Screw	FOX983-95-537-62	\$249.00
125C/400R-D	3C-9R-D, 20.4" Ext, Seal Screw	FOX983-95-537-63	\$249.00
125C/470R-D	3C-10R-D, 20.4" Ext, Seal Screw	FOX983-95-537-64	\$249.00
125C/550R-D	3C-11R-D, 20.4" Ext	FOX983-95-537-65	\$249.00
125C/625R-D	3C-12R-D, 20.4" Ext	FOX983-95-537-66	\$249.00

8.9" Track All Steel Shock - Shrader Valve

75C/200R	1.5C-5R, 23.7" Ext	FOX983-95-509-13	\$249.00
75C/230R	1.5C-5.5R, 23.7" Ext	FOX983-95-509-14	\$249.00
115C/200R	2.75C-5R, 23.7" Ext	FOX983-95-509-16	\$249.00
115C/230R	2.75C-5.5R, 23.7" Ext	FOX983-95-509-18	\$249.00
100C/200R	2.75C-8R, 23.7" Ext	FOX983-95-509-27	\$249.00
100C/200R-M	2.75C-5R-M, 23.7" Ext	FOX983-95-509-31	\$249.00
275C/175R-M	6.5C-4.5R-M, 23.7" Ext	FOX983-95-509-32	\$249.00
325C/175R-M	7.5C-4.5R-M, 23.7" Ext	FOX983-95-509-33	\$249.00
375C/175R-M	8C-4.5R-M, 23.7" Ext	FOX983-95-509-34	\$249.00
400C/175R-M	9C-4.5R-M, 23.7" Ext	FOX983-95-509-35	\$249.00
275C/150R-M	6.5C-3R-M, 23.7" Ext	FOX983-95-509-36	\$249.00
325C/150R-M	7C-3R-M, 23.7" Ext	FOX983-95-509-37	\$249.00
375C/150R-M	8C-3R-M, 23.7" Ext	FOX983-95-509-38	\$249.00
400C/150R-M	9C-3R-M, 23.7" Ext	FOX983-95-509-39	\$249.00
100C/200R-D	FRRT, 23.7" Ext	FOX983-95-509-53	\$249.00
400C/100R-D	9C-2.5R-D, 23.7" Ext	FOX983-95-509-67	\$249.00
470C/100R-D	10C-2.5R-D, 23.7" Ext	FOX983-95-509-68	\$249.00
550C/100R-D	11C-2.5R-D, 23.7" Ext	FOX983-95-509-69	\$249.00

8.9" Track All Steel Shock - IMCA Valve

75C/200R	1.5C-5R, 23.7" Ext, Seal Screw	FOX983-95-539-13	\$249.00
75C/230R	1.5C-5.5R, 23.7" Ext, Seal Screw	FOX983-95-539-14	\$249.00
115C/200R	2.75C-5R, 23.7" Ext, Seal Screw	FOX983-95-539-16	\$249.00
115C/230R	2.75C-5.5R, 23.7" Ext, Seal Screw	FOX983-95-539-18	\$249.00
100C/200R	2.5C-8R, 23.7" Ext, Seal Screw	FOX983-95-539-27	\$249.00
100C/200R-M	2.5C-5R-M, 23.7" Ext, Seal Screw	FOX983-95-539-31	\$249.00
275C/175R-M	6.5C-4.5R-M, 23.7" Ext, Seal Scr	FOX983-95-539-32	\$249.00
325C/175R-M	7.5C-4.5R-M, 23.7" Ext, Seal Scr	FOX983-95-539-33	\$249.00
375C/175R-M	8C-4.5R-M, 23.7" Ext, Seal Screw	FOX983-95-539-34	\$249.00
400C/175R-M	9C-4.5R-M, 23.7" Ext, Seal Screw	FOX983-95-539-35	\$249.00
275C/150R-M	6.5C-3R-M, 23.7" Ext, Seal Screw	FOX983-95-539-36	\$249.00
325C/150R-M	7C-3R-M, 23.7" Ext, Seal Screw	FOX983-95-539-37	\$249.00
375C/150R-M	8C-3R-M, 23.7" Ext, Seal Screw	FOX983-95-539-38	\$249.00
400C/150R-M	9C-3R-M, 23.7" Ext, Seal Screw	FOX983-95-539-39	\$249.00
100C/200R-D	FRRT, 23.7" Ext, Seal Screw	FOX983-95-539-53	\$249.00
400C/100R-D	9C-2.5R-D, 23.7" Ext, Seal Screw	FOX983-95-539-67	\$249.00
470C/100R-D	10C-2.5R-D, 23.7" Ext, Seal Screw	FOX983-95-539-68	\$249.00
550C/100R-D	11C-2.5R-D, 23.7" Ext, Seal Screw	FOX983-95-539-69	\$249.00

Shock Body Base

Alum Thread Body/Tube	FOX207-14-045	\$39.50
Alum Thread Body/Tube 9 Inch Body	FOX207-14-061	\$39.50
Front Shock Body Base Valve	FOX204-18-080	\$52.55
Body Tube - Track Steel Shocks 8.8in	FOX204-18-082	\$57.98

Aluminum Body

1/2 x 10.100 TLG jam nut shaft for 7 Inch steel hybrid	FOX230-11-101	\$29.50
1/2 x 10.60 TLG jam nut shaft for 7 Inch Alum bulb shock	FOX230-11-106	\$29.50
1/2 x 12.10 TLG jam nut shaft for Alum Bulb and Steel Body 9" shocks	FOX230-11-121	\$29.50

Steel Body

Front shock shaft base valve 10-1/4	FOX229-99-094	\$25.67
Shaft .498 OD 10.000 TLG Steel Chrome 1.200 Post Length	FOX229-99-100	\$29.50
Shaft .498 OD 11.700 TLG Steel Chrome 1.200 Post Length Solid	FOX229-99-117	\$29.50
Rod-B 7.25 Inch	FOX229-99-102	\$29.50
Rod-B 9.1 Inch	FOX229-99-120	\$29.50



Coil Springs

Silver Powder Coated

1-7/8" ID x 8" Hgt • Rates: 140, 160, 180, 200, 250, 300, 350, 400, 450.....QA1 8S(Rate)\$42.93
 1-7/8" ID x 8" Hgt • Rates: 150, 160, 165, 250.....QA1 10S(Rate).....\$42.93

Pollshed & Chrome Plated

1-7/8" ID x 8" Hgt • Rates: 125, 140, 150, 175, 350, 400.....QA1 8SM(Rate).....\$55.81
 1-7/8" ID x 10" Hgt • Rates: 95, 105, 115, 125, 150, 175, 200, 225, 250, 275, 400.....QA1 10SM(Rate).....\$55.81
 2-1/2" ID x 7" Hgt • Rates: 250, 300, 350, 400, 450, 550, 650.....QA1 7HT(Rate).....\$47.22
 2-1/2" ID x 9" Hgt • Rates: 140, 220, 300, 350, 400, 450, 500, 550, 650.....QA1 9HT(Rate).....\$47.22
 2-1/2" ID x 10" Hgt • Rates: 100, 125, 150, 175, 200, 225, 250, 275, 300, 325, 350, 375, 400, 450, 500, 550, 600, 650,QA1 10HT(Rate) \$47.22
 2-1/2" ID x 12" Hgt • Rates: 80, 95, 110, 130, 150, 175, 200, 225, 250, 275, 300, 325, 350, 375, 400, 450, 500, 550, 600.....QA1 12HT(Rate) \$47.22
 2-1/2" ID x 14" Hgt • Rates: 80, 95, 110, 130, 150, 175, 200, 225, 300, 350.....QA1 14HT(Rate) \$47.22

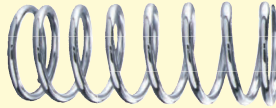

Rear Coil-Over Shock Mount for Std Birdcage

Coils. Optional. This is an easy way to run coils when you want. Replaces the roller and std shock mt on your torsion style birdcages. Fits BRP std and adj birdcages.
 BRP9485.....\$102.52



RR Drop Down Shock Mt

Drop down coil over mount for LR or RR short link cars. An alternative to the version with the weight jack screw assembly.
 BRP9574.....\$135.52



Shock Inflation Unit

BRP9430.....\$150.64



Digital Shock Inflator

Reads to 300 psi w/ .1 psi units. Special chuck prevents pressure loss & inaccurate settings. Quick & accurate settings - guaranteed.
 LON50483.....\$113.40



Circle Track Coil Over Kits

Kits include components for 1 shock and contain some of the following:

- Use With Alum Shocks, 1 7/8" I.D. Spr**
82 Series Small BodyQA1CK8201\$26.89
- Use With Steel Shocks, 1 7/8" I.D. Springs**
75 Series, Cone Cap, With Jam Nut.....QA1CK1955C \$41.76
70 Series, Cone CapQA1CK7001.....\$44.86
- Use With Alum Shocks, 2 1/2" I.D. Springs**
60 Series, 6" and 7"QA1CK6005.....\$62.82
60 Series, 8" and 9"QA1CK7001.....\$44.86
16 and 62 Series.....QA1CK6201.....\$26.89
- Use With Steel Shocks, 2 1/2" I.D. Springs**
20, 26, 26A, 26V, 28, 28A, 28V, 50 Series
7"QA1CK5005.....\$62.82
9"QA1CK5007.....\$62.82
75 Series, Cone Cap, With Jam Nut.....QA1CK1951C \$49.36
55 Series, w/Jam Nut.....QA1CK1971C \$44.86
- Use w/Both 7" And 9" Shocks w/5" O.D. Springs**
26, 26A, 26V, 28, 28A, 28V & 50 Ser ..QA1CK5009.....\$98.75



Left Rear Speed Chain Assembly

Stops the suspension's travel before the shock reaches full extension. Adjusts the total amount of allowable chassis roll. It is important to note that traction creates roll, roll does not create traction. Being able to easily adjust this can help achieve a more balanced race car. Maintains load at the left rear tire by limiting how far the torsion bar/spring can extend. The more it extends the "lighter" the tire becomes. The internal spring helps cushion the abrupt stopping of motion that commonly occurs when topping a shock out without a limit chain installed. This helps the tire maintain traction during full chassis roll. This kit comes with all mounting hardware and brackets needed for installation. The chain is cut to length depending on your mounting brackets and chassis.



Kit Includes: 1.5" Dia Mt Bkt , 3.0" Axle Tube Mount Bracket, Left Rear Speed Chain Housing, 24 inches of 3/16 Chain (Yield strength of 2,400 lbs), 24" of black shrink wrap.
 DIG54-000\$250.00



Left Rear End Limiter Chain

This rubber cushioned droop limiter is adjustable so you can have stock droop, or 1/2" and 1" less. You can also unhook the chain and have a totally stock setting. The main clamp and body hook to a 3" axle tube and ride on the axle to leave ample clearance for dry sump lines. The top clamp goes over the 1-1/2 bar that the master cyls are mounted to on a BRP car. Shrink wrap included for the chain A softer (red) biscuit BRP427-2 or a stiffer (black) biscuit BRP427-1 are available.
 BRP9540.....\$277.49



Shock Slider 1-1/4" with set screw

Machined from 6061 alum. Has 3 pinch bolts for greater clamping force. Also has set screw so slider will not slide even in roughest track conditions. Comes complete with all spacers and bolts.

Red.....BRP9060\$50.20
 Black ...BRP9060BK ..\$50.20



Shock Sliders

1 pc. 1-1/2" Mount
 Red Left.....BRP9143L.....\$36.31
 Black Left.....BRP9143LBK.....\$36.31
 Red Right.....BRP9143R.....\$36.31
 Black Right.....BRP9143RBK.....\$36.31

2 pc. 1-1/4" Mount
 Red.....BRP284.....\$28.84
 Black.....BRP284BK.....\$28.84

2 pc. 1-1/4" Mount w/stud (Dbl. Clamp)
 Red.....BRP4289.....\$36.87

2 pc. 1-1/2" Mount
 Red.....BRP286.....\$28.84



Shock Sliders

Front for 1-1/2"TEOPR026 ..\$46.80
 Rear for 1-1/4"TEOPR027 ..\$48.10

Shock Tower Locks

1-1/2" inside diameter lock collar to prevent shock slider from sliding up shock tower.
 TEOT010C\$16.25



Monotube Hyperscrew Fill Tool

26 and 28 Series
 QA17791-140.....\$116.71



Coil-Over Shock Adjusting Tool

Makes adjusting coil-over shocks much easier than the commonly used hammer and screwdriver method. Works with Avo, Hal, Koni, Bilstein, Carrera, Monroe & most other coil-over shocks with adjusting nuts up to 3-1/4" diameter. Manufactured of cast steel with finger indents for sure-grip operation.
 MOR62030\$28.44



Shock Workstation

It lets you hold on to your shock body and the shaft at the same time, making it a lot faster, easier, and cleaner to work on your shocks. Just put the Joe's Workstation in a vise and you're ready to go, or mount it securely to a workbench or pit cart with our base. (Sold separately)



Shock Workstation ..JOE19200..\$199.95
 Workstation Base.....JOE19250..\$41.95

Drip Cup

Catch the oil before it runs down the side of your shock. Designed to fit shocks from 1-1/2" to 2-1/8" in diameter..... JOE19300.....\$62.95



Shock Travel Indicator Kit

Check the compression and rebound travel of coil-over shocks at a glance. Clamp the alum bracket to the body of the shock and bolt the opposite end to the existing shock eye bolt. May be used with most coil-over and non-coil-over shocks. Clamp is included.
 ALL60094\$39.99



Shock Protector

Plastic shock protector slides over aluminum threaded body shock to protect against wear from spring. Protector measures 6" from spring seat to end, has an I.D. that measures 2.25" and works with all 2.5" I.D. springs. Unit should just cover shock body and may need to be cut to specific length.
 ALL64200\$22.99



SHOP SET-UP



"Four Bubble" Caster/Camber Gauge

Check camber from +8 to -8 in 1/4 degree increments. Caster readout from +8 to -4 in 1/4 degree increments.

Bubble Gauge & Case Only.....QUA200-3300.. **\$99.95**

Gauge & Magnetic adapter.....QUA200-3302.. **\$129.95**

Gauge & GM adapter (3/4-20).....QUA200-3304.. **\$119.50**

Gauge & Wide 5 adapter (1 13/16-16).....QUA200-3306.. **\$119.50**

Wide 5 adapter only.....QUA200-3400.. **\$22.50**

GM adapter only.....QUA200-3401.. **\$24.00**

Big Ford adapter only (13/16-20).....QUA200-3402.. **\$24.00**

Pinto adapter only (3/4-16).....QUA200-3403.. **\$24.00**

Stock Car Products Adapter (27/32-20).....QUA200-3404.. **\$38.32**

Magnetic adapter only.....QUA200-3405.. **\$36.00**

Kart adapter (5/8-18).....QUA200-3408.. **\$31.50**

Wide 5 steel dust cover adapter only.....QUA200-3407.. **\$29.99**

Bump Steer Gauge

It comes complete with dial indicators and everything you need to check with wheels on or off the car.

Drilled.....QUA200-3030..... **\$129.00**

Blank.....QUA200-3031..... **\$129.00**

Caster Camber Gauges

Fully adjustable to fit any steel hub or wheel. Measures from -7 to +7 degrees w/1/8 degree accuracy.

Hub TypeQUA200-3010..... **\$45.38**

Rim Type.....QUA200-3020..... **\$39.95**

Stagger Gauge

No more jacking up and rolling a tape around the tire. Engraved measurements are accurate and won't wear off.

20" - 50"QUA200-3040..... **\$69.50**

60" - 107"QUA200-3050..... **\$89.50**

Toe Gauges

Simply use the pointers to place a mark on the rear of the tire, then roll forward and compare pointers against the mark. All you add is a piece of 3/4" conduit in the desired length.

QUA200-3000..... **\$39.95**

Analog Radius Plates

An excellent way to get the proper set-up on your car at an economical price. Exactly the same turntables as above except with an adjustable needle instead of the digital window. Rotates 30° in each direction. Reads in degrees. Permanently engraved markings won't wear off.

QUA200-2150..... **\$289.50**



Safety Wire Drill Jig

This tool centers holes in bolts and helps avoid broken bits and colorful language. Fits bolts 1/8" to 5/8".

Safety Wire Drill Jig.....QUA200-3055..... **\$39.95**

Safety Wire.....BSC80100..... **\$15.95**

Safety Wire Pliers

Pull, cut and twist safety wire with these pliers.

9".....BSC80101..... **\$29.12**

6".....BSC80102..... **\$27.18**

Tube Bender 180°

1/4, 5/16, 3/8 o.d.

BSC70101..... **\$9.00**

Tube Bender Pliers

3/16, 1/4 O.D.

BSC70102..... **\$42.61**



Digital Level

It works great to check spoiler, A-arm, pinion, trailing arm angles or whatever else you might need to measure to 1/10th of a degree. The easy to read display has a backlight for night use with an auto shut off to keep the battery fresh. The Level can be user calibrated in seconds. The machined steel leveling surface is wide for true and accurate, eliminating distortion that can affect accuracy on models with plastic leveling surfaces.

JOE56500..... **\$83.95**

Billet Tire Scribe

Use to make a true running line on the face of the tire for toe-in setting. Use with Toe-In Gauge LON79620. Folds up for easy storage.

LON79610..... **\$86.35**

Plumb Bob Kit

Square rear end. Lots of other uses.

LON50820..... **\$27.95**

Aluminum Toe Plates (pair)

Quickest and simplest way to measure toe. Rest one of these plates against the tire on each side and measure toe directly using the 2 tapes (included). Formed design is rigid for accuracy and stays put against the tire. Magnets hold tape in place

Dimensions: 23-1/2" x 9"

LON79501..... **\$65.21**

Stagger Gauge

Gauge measures tire dia & automatically converts it to circumference. Gives accurate & consistent stagger measurements every time. Measures 65" to 115" in 1/4" increments.

ALL10116..... **\$52.99**

Sprint Car Drag Link Tether

Keeps drag link tethered to the chassis if the drag link becomes disconnected. Tethering of drag link is required by most sanctioning bodies. 24" long x 1" wide, woven nylon.

ALL10252..... **\$15.99**

Engine Cradle

SBC cradle is made from 1" square tubing and powder coated black. Does not have provisions for adding wheels.

ALL10171..... **\$39.99**



Air Mover Fan 900 CFM 115V

It features an advanced blade design that produces a high airflow and quiet operation. The unique shape of the fan housing allows multiple mounting positions to provide ventilation and cooling where it is needed. Ideal for use in the shop, trailer, or at the race track.

- High Volume Airflow - 900 CFM
- Built-in Carry Handle
- Uses Only 2 Amps when Running
- 15' Long Cord • 1/4 HP Motor • 16.5 Lbs
- 12 Amp Power Outlet - Allows Use of Tools, Lights, or Daisy Chain Operation of Multiple Fans
- Overall Dimensions: 19.5" L x 17.5" W x 8.6" T
- Ideal for Cooling Down Race Engines & Trans

NEW



Shuttle Gauge

Versatile mini-gauge attaches to pump or can be used alone. Gauge face rotates 360° and reads to 300 psi for use with tires, forks or shocks. Works w/ Presta and Schrader valves and features a precision bleeder valve and Pressure-Rite anti-air loss connector. Reads to 300 psi for use with tires, forks and shocks. Internal check valve prevents air loss when removing gauge from tires, forks or shocks. Air release button for precise adjustment of tire pressure. Unique internal check valve on our shock pumps isolates the pump from the fork or rear shock preventing air pressure loss during removal of pump head.

BSC70050..... **\$41.95**

SIMPSON Fueler Aprons

Designed to repel fluids and protect against spills, the Fueler Apron features velcro on the neck and waist straps for easy adjustments and quick release. SFI rated 52.1 Rated. Available in solid or split front including kevlar straps.

SIM39042.. **\$199.95**



Nitrogen Fill Tool

0-400 PSI.....BILB4-KT0-Z021A00..... **\$106.68**



Toe Plates

Check the toe of your race car quickly and easily. Just prop a toe plate against each front tire and measure. Includes 2 tape measures & 2 toe plates included.

JOE32600..... **\$62.95**

Moose Blocks

Chassis set-up blocks are adjustable in 1/4" increments. A quick release pin holds block at desired height. Bottom surfaces of blocks are contoured to fit steel tubing or any flat surface and have magnets for holding block to chassis. Short blocks adjust 1.75"-4". Tall blocks adjust 3"-6"

ALL10720.....Moose Blocks Short..... **\$74.99**

ALL10721.....Moose Blocks Tall..... **\$85.99**



Tube Cutters

Cut plastic alum, copper or steel tubing without distorting or crushing. Std Cutter works with tubing from 1/8" up to 1-1/8" and has wide rollers for even tracking of cutter wheel, built in reamer for cleaning inside of tubing & an extra cutting wheel. Mini cutter can cut tubing from 1/8" to 5/8" in tight areas.

Standard.....ALL11011..... **\$11.99**

Mini.....ALL11010..... **\$6.99**

Double Flare Tool

Double flares 3/16", 1/4", 5/16", 3/8" and 1/2" steel or alum and .040" copper tubing at 45°, the most common flare used in custom length brake and fuel lines. Includes detailed instructions & a convenient plastic storage case.

ALL11015..... **\$29.99**

SHOP & TRAILER



5 Gallon Motorsport Containers

Round 5 Gallon - Red	VP3012	\$24.95
Round 5 Gallon - White	VP3022	\$24.95
Round 5 Gallon - Blue	VP3032	\$24.95
Square 5 Gallon - Red	VP3512	\$24.95
Square 5 Gallon - White	VP3522	\$24.95
Square 5 Gallon - Blue	VP3532	\$24.95
Square 5 Gallon - Yellow	VP3552	\$24.95
Square 5 Gallon - Green	VP3562	\$24.95

Container Accessories

Jug Cap	VP3042	\$7.95
Tube	VP3044	\$9.56



Drum Wrench

VP3061	\$22.95
--------	---------



Syphon Pump

ALL40114	\$18.99
----------	---------

Fire Systems



Bottle Type: Pull Systems.
The RC-500 is a 5# manual pull system. The bottle is made of aluminum; the dimensions are 17.20" X 4", and weighs 9lbs.

- 1-Filled 5# Manual System
- 1-Activating Head
- 1-Pull Cable
- 1-Discharge Adapter
- 2-Nozzle Adapters
- 2-Nozzles
- 5 lb w/cableFIRRC500\$418.95
- 10 lb w/cableFIRRC1000\$620.95

- 1-Tubing Tees
- 1-Discharge Tubing Roll
- 1-Alum Mounting Bkt Plate
- 2-SS Mounting Bkts



Funnels & Filters

8" Round	JAZ555-008-06	\$17.42
11" Round	JAZ555-011-06	\$27.02
14" Triangular	JAZ550-014-06	\$17.42
16" Triangular	JAZ550-016-06	\$27.02
15" D-Shaped	JAZ560-015-06	\$32.32

Funnel Filter 60 microns, fits all JAZ funnels except 8" Round...JAZ500-000-01...\$24.52

Funnels

Heavy duty plastic funnels are perfect for topping off fuel or other liquids.

Funnel 2 QT W/Brass	ALL40102	\$4.99
Funnel 1 Pint W/Brass	ALL40104	\$4.99

Extended Funnels

Built-in hang tab allows funnel to be secured to body or frame for hands-free filling.

18" Flex Spout Funnel	ALL40107	\$5.49
15" Straight Spout Funnel	ALL40108	\$6.59

7 Gallon No Glug Jug

Easy enough for one racer to pour fuel into their race car. Eliminates the hassle and frustration of handling the bulk of a 15 Gallon Jug. Features a 2-1/4" O.D. stepped pour spout that can be cut to desired diameter to adjust flow rate. The jug includes a 2-1/4" spout hose and a 3/4" vent with cap to keep fuel vapors in and prevents spillage when not in use.
JAZ710-107-05...\$81.30

Fire Extinguisher Bkt

The pull pin has an oversized billet knob and is red anodized to spot quickly. The mounting housing is strong and indexes for a quick connection. Hose clamp screws are hidden in the housing for a clean appearance.

1-1/4" Extinguisher Bracket	JOE12821	\$157.95
1-1/2" Extinguisher Bracket	JOE12822	\$157.95
1-3/4" Extinguisher Bracket	JOE12824	\$157.95
2" Extinguisher Bracket	JOE12826	\$157.95
Flat Panel Mount Extinguisher Bkt	JOE12830	\$136.95

Deluxe Aluminum Mud Scraper

Remove the stickiest mud and clay without damaging paint. Lightweight and 32" long to reach wings, deck lids and undercarriage. Use the hole in end to hang scraper.
ALL44165...\$17.99

Track Mats

Mats fold for easy storage and are ideal for use on asphalt, dirt, in the pits or on the garage floor. Vinyl coated pad measures 52" x 24" unfolded, 12" x 24" folded.

Black	ALL10126	\$29.99
Red	ALL10127	\$29.99
Blue	ALL10128	\$29.99

Quick Change Gear Tray

All aluminum construction. Easy to pour hot oil with built in corner spout. Comfortable ergonomic handle.
KIR99100...\$49.00

Drain Pan

Plastic drain pan has molded in handles and pour spout.
13-1/2" x 11" x 4", 7 qt cap
ALL40112...\$6.99

Quick Change Drain Pan

Alum Drain Pan is a must when changing quick change gears. Built-in perforated shelf holds gears and allows lube to drain into pan. Pan is 10-1/4" wide, 12" long and 3-3/4" deep.
ALL14166...\$47.99

Aluminum Ford 9" Gear Tote

Keep Ford 9" third member in a neat and clean environment. Built-in handles for easy carrying.
ALL14168...\$79.99

Jug Racks

Heliarc welded .090 aluminum racks mount to floor or wall. Holds round or square jugs.

1 Jug Rack	PIT180	\$74.99
2 Jug Rack	PIT181	\$94.99
3 Jug Rack	PIT182	\$109.99
4 Jug Rack	PIT183	\$139.99

Dial-In Marker Holder

Finally a way to hold a dial-in marker in your drag car. Rotates 360° to fit roll cage bar.

1 1/2" bar	PIT236M	\$54.99
------------	---------	---------

Std Tool Tray

Used by many of the top racing teams. Keeps tools and parts organized when working on engines. 18" L x 9" H x 14" W

PIT120S	Standard	\$169.99
PIT120D	Dominator	\$169.99
PIT118	Extra Ring Standard	\$22.99
PIT119	Extra Ring Dominator	\$22.99

Adjustable Tire Rack

This handy tire rack folds down when you need it and easily folds against the wall for more room when empty. It is available in 48 or 64" lengths, but expandable with extension kits.

48" Adj Tire Rack	PIT294	\$359.99
64" Adj Tire Rack	PIT295	\$439.99
48" Lengthening Kit	PIT294E	\$299.99
64" Lengthening Kit	PIT295E	\$380.99

Trailer Door Cabinet

Fold down table which is great for holding a weather station, tools, small parts, etc. The cabinet is fabricated from .090 aluminum for max durability.
30" H x 25" W x 5-1/2" D

PIT320	\$184.99
--------	----------

Junior Trailer Door Cabinet

The junior trailer cabinet includes: Fold down table, Paper towel holder, 2 shelves for storage
19-1/2" H x 12" W x 4-1/2" D

PIT321	\$119.99
--------	----------

Oil Storage Cabinet

An excellent way to store and organize oil products. The top shelf holds 8 aerosol cans. 3 lower shelves holds 29 quarts of oil or filters.
36" H x 24-1/2" W x 5-1/2" D

PIT310	\$169.99
--------	----------

Junior Oil Cabinet

For those who need the storage in a smaller size, the junior neatly holds 12 quarts of oil.
18" H x 16" W x 5-1/2" D

PIT313	\$99.99
--------	---------

Tie Down Hangers

Neatly stores ratchet tie downs on trailer wall while at an event. Creates more floor space. Store 2 ratchet tie downs per unit. Fabricated from .090 alum for max strength. 8" X 3" (L x D)
PIT217...Single Bracket...\$18.99
PIT222...Set of two bkts...\$32.99

Spare Tire Holder

Tire cradles snugly in holder for a secure ride. Can be mounted on the wall or floor.
27" Wide...PIT289...\$169.99
34" Wide...PIT287...\$169.99

1 Bay Helmet Shelf

Hangs up to 8 uniforms. Fabricated from .090 alum for max strength.
14" L x 15" W x 12" H
PIT330...\$124.99

2 Bay Helmet Shelf

Provides common area for all driver's gear; keeps trailer neat.
28-1/4" L x 15" W x 12" H
PIT331...\$174.99

Deluxe Air Bracket

Wrap your air hose out of the way, plus great for storing air chuck, air gauge, small tools inside.
PIT223...\$40.99

Nitrous Bottle Rack

These racks keep bottles vertically and out of the way. They easily mt to the floor or wall. All are 13" high & 7-1/4" deep from wall.
2-Bay...PIT249...\$109.99
3-Bay...PIT250...\$139.99
4-Bay...PIT251...\$149.99
5-Bay...PIT252...\$169.99
6-Bay...PIT253...\$199.99

ROBSC-501

Multi-Mode Stopwatch

Event • Lap • Split

Lap or split timing. Can be used for single events. 1/1000 2nd resolution to 24 hours. Auto release to running time. Single action time readings. Time out (pause) timing. Audible beep confirmation. 1 year warranty. 5 yr battery life.

ROBSC-501W...\$23.95

Robic®



Longacre

2 Car Stopwatch Clipboard w/ Robic SC 606W

2 Car Clipboard

Lightweight aluminum - won't break like plastic can. Powder coat finish with edge protectors. Rubber feet prevent sliding and protect car's finish. Professional color lap charts included with practice times on back

2 Robic SC 606W watches

Clocks every lap. Counts laps to 999. 50 Lap Memory. LON22321...\$124.85

Lap Timing /Race Scoring Sheets

Lap times and practice times on back. Punched for a 3 ring binder. Pk 2 pads, 50 sheets per pad.

LON22525...\$8.84

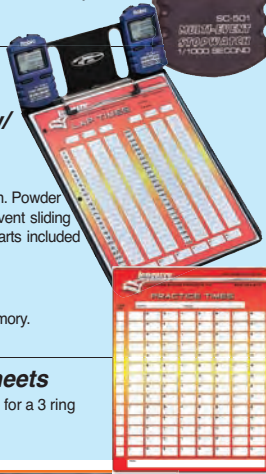

JOES RACING PRODUCTS

Car Covers

It is lightweight and less bulky for easy storage. The cover installs quickly to keep the heat out on hot days and it dries in a hurry when you get caught in the rain. Heavy Denier Nylon protects your car without the need of a felt lining that can soak up water and mildew. We added a zippered opening on the windshield, rear window, and driver's window so you can drive your car through the pits or into the trailer and see where you are going. Comes with a compact storage bag that saves you precious room in your hauler. Includes grommets.

JOE27500...\$136.95



Car Covers

Cut specially to fit race cars - Keep your car cooler and cleaner between races. Heat reflective silver color. Soft liner will not scratch paint. Zippered window to get in and out. Moisture resistant. Eyelets along bottom to secure cover from tampering

Open Wheel Modified (Northeast DIRT Modified) Car Cover

Custom Designed - Great for Northeast DIRT Modifieds, IMCA, UMP type cars LON11154...\$181.84

Longacre

Pavement Late Model Car Cover

Will fit most all Late Model cars - All Pro, ASA, SW Series, etc. LON11150...\$172.72



Dirt Late Model Car Cover

Custom Designed for Dirt Late Model Cars LON11152...\$217.16



PENN STATE RACING

BSC Components



Racertape

2" x 180 feet

Black.....BSC50010-180.....\$6.95
 Yellow.....BSC50020-180.....\$6.95
 Blue.....BSC50030-180.....\$6.95
 Teal.....BSC50035-180.....\$6.95
 Silver.....BSC50040-180.....\$6.95
 Green.....BSC50050-180.....\$6.95
 Red.....BSC50060-180.....\$6.95
 Burgundy.....BSC50065-180.....\$6.95
 Orange.....BSC50070-180.....\$6.95
 Purple.....BSC50080-180.....\$6.95
 White.....BSC50090-180.....\$6.95

Racertape

Checker Board Tape

Size: 2" x 45 feet

BSC50100...\$6.75



Racertape

2" x 90 feet

Black.....BSC50010.....\$4.50
 Yellow.....BSC50020.....\$4.50
 Blue.....BSC50030.....\$4.50
 Teal.....BSC50035.....\$4.50
 Silver.....BSC50040.....\$4.50
 Green.....BSC50050.....\$4.50
 Brown.....BSC50055.....\$4.50
 Red.....BSC50060.....\$4.50
 Burgundy.....BSC50065.....\$4.50
 Orange.....BSC50070.....\$4.50
 Purple.....BSC50080.....\$4.50
 White.....BSC50090.....\$4.50

Dull Finish Gaffer Tape

- Easy to Write On
- Doesn't leave residue
- Dull Finish

2" x 83 feet

Black.....BSC50210.....\$9.95
 White.....BSC50290.....\$9.95
 Red.....BSC50260.....\$9.95

Neon Colors 2" x 75 feet

Neon Yellow.....BSC50215.....\$10.95
 Neon Green.....BSC50220.....\$10.95
 Neon Pink.....BSC50230.....\$10.95

Neon Orange.....BSC50240.....\$10.95

Neon Colors 1" x 150 feet

Neon Yellow.....BSC50115.....\$10.45
 Neon Green.....BSC50120.....\$10.45
 Neon Pink.....BSC50130.....\$10.45
 Neon Orange.....BSC50140.....\$10.45

3000 lb ATV Winch

Winches

w/Mini-Rocker Switch Mounting Channel Roller Fairlead

All Terrain Vehicle 12 volt electric DC winches have a heavy duty steel housing and frame components for maximum strength, durability and reliability. The bulldog self recovery ATV winch has a premium series wound 12V DC 1.0 hp (0.75 kw) on 2,000lb. The bulldog winch has a handlebar mounted mini rocker switch, powers load in and out with automatic load holding brake, freespooling clutch for quick wire rope deployment.

BUL15002...\$153.06



6000 lb Winch with Roller Fairlead

Bulldog 6,000lb 12 volt electric DC winches have a heavy duty steel housing and frame components for maximum strength, durability and reliability. The bulldog 6,000 pound self recovery winch has a premium series wound 12V DC 1.87 hp (1.4 kw) motor, powers load in and out with automatic load holding brake, freespooling clutch for quick wire rope deployment.

BUL10004...\$371.43

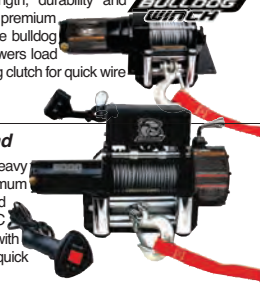

Ratchet Tie Down

JAZCAR-008-08...\$38.49

D-Ring Ratchet

JAZCAR-108-08...\$50.57

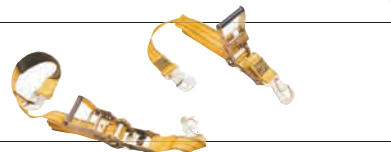

Heavy Duty Axle Strap

Don't wrap a strap around your rear and hook it on itself, it scratches up your rear and will eventually cut into the strap. Sold individually.

JAZCAR-224-08...\$18.11

JAZ Products

4 Piece Ratchet Tie Down Set

4 piece 1"x15 foot Tie Downs. Adjust from 4 feet to 15 feet in length. Quick and easy cushioned thumb release with automatic lock ratcheting action. 1,500 lb. test polyester webbing. 800 lb. max rated capacity.

SCO126-724...\$16.95



Ratchet Tie Down w/D-Ring

SCORTD28...\$19.95

10' Ratchet Combo Tie Down

GFO3610...\$34.99

G-FORCE RACING GEAR

33" Sleeved Axle Strap

GFO2503...\$11.99

21" Sleeved Axle Strap

GFO2502...\$10.99



GPS Hot Lap In-Car Timer

In-car timing is triggered by GPS signal. No trackside "beam" needed. Driver sees his lap times as they happen. Try different lines to find the fastest. 3" backlit display. You can divide the track into segments and time each one separately. Find where you're fast and where you're not. Run several laps & compare the segments side by side. You can also time 0-60 mph and time 1/4 mile with time and speed. Super accurate timing by the ultra sensitive GPS sensor.

LON21730...\$345.61

Longacre

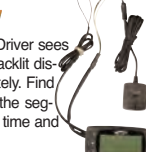

ENGINE TOOLS - TOP END



Valve Lash Wrenches

Allstar Valve Lash Wrenches save precious time and prevent aggravation during valve adjustment. No more fumbling with two separate wrenches. Available for Jesel, T and D and other common poly-lock style rocker assemblies.

7/16" Adjustable Wrench, 1/8" Allen Wrench, Jesel ALL96400.....\$31.99



Feeler Gauges

Feeler gauges are a very valuable tool to have around the shop or trailer. Use in engine assembly to check connecting rod side clearance, piston ring end gap, spark plug gap and valve lash. Gauges have Metric and SAE sizing designations etched in each blade. Choose straight or angled sets.

Feeler Gauge Straight.....ALL96420.....\$6.99
Feeler Gauge Angled.....ALL96421.....\$6.99



Valve Train Trays

Lightweight with built-in carrying handles. Valve tray holds valve springs, valve locks, and the largest of valves. Rocker tray holds pushrods, lifters, poly locks, spark plugs and rocker arms. Designed for the home mechanic as well as the professional.

Valve and Spring Tray.....JAZ735-001-06...\$34.35
Rocker Arm and Lifter Tray.....JAZ735-002-06...\$33.72



Cylinder Head Work Stand

Work stand is designed for use with all popular cylinder heads and provides an inexpensive, safe and sure mt for all jobs from porting to ccing the chambers. Disassembles for easy storage in tool box. 2 supports per set.
MOR62080.....\$47.22

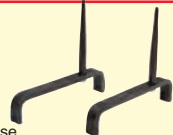

Carburetor Work Stand

Designed to hold Quadrajet and both standard and spread-bore Holley carbs, this tool greatly simplifies carburetor work. Manufactured of cast aluminum with open center and mounting pegs.
MOR62070.....\$24.20

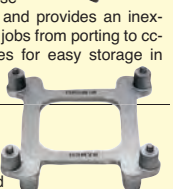

Carburetor Jet Tool

Designed with a stronger, fully machined tip that slides over jet, holding it firmly in place. Short design, sure-grip handle simplifies jet removal and installation in crowded engine compartments. Fits Holley type carb jets.
MOR62293.....\$13.52



Carburetor Drain Cup

Now you don't have to spill fuel all over the engine when removing fuel-bowl screws to service Holley carburetors. Gary Williams designed Carburetor Drain Cup uses a channel handle to catch dripping fuel and direct it to a holding cup. Made from fuel resistant polyethylene.
MOR65805.....\$9.69



Power Valve Tester

Convenient tool checks Holley Power Valves for ruptured diaphragms to prevent engine flooding. Remove knurled cap and screw in the Power Valve; cut-away section of tool allows visual inspection of valve's operation. CNC machined from 6061-T6 alum & blue anodized to prevent corrosion. Requires the use of a hand-operated vacuum tester (available at most auto parts stores)
MOR62295.....\$43.13



Valve Spring Height Micrometers

Quickest, easiest, most accurate way to measure valve spring installed height. Install just like a spring, then is expanded until it fully seats valve, locks and retainer. Simulated installation allows ultra precise readings. Tool is read like a micrometer and is accurate to .001".
1.400" to 1.800".....COM4928.....\$75.84
1.600" to 2.200".....COM4929.....\$84.72
1.600" to 2.200" for Beehive Springs COM4930.....\$75.30



Valve Seal Installer

CNC-machined aluminum valve sealer makes installing Teflon seals easy. Works with .500" and .531" Teflon seals. Prevents seal distortion or gouging during installation. Anodized for durability.
COM5334.....\$22.88



V-Style Aluminum Head Holders (Pair)

Perfect for whenever you perform any type of cylinder head modifications or maintenance. Stands give ability to put the heads in any position and rotate as necessary. Two version available? Cast aluminum and welded steel. Handy for holding cams and crankshafts
COM5331.....\$120.17



Magnifying Flashlight

LED Powerful "LED" Light Source For Spark Plugs
6.4X Fire Polished, B1-Convex Optic Lens. Powerful white light LED floods the insulator cavity with light for accurate inspections. Longer life LED lamp. Lower voltage for longer battery life. Easy one-handed on/off switch. Black anodized billet aluminum flashlight housing. 2 AA batteries included.
MOR62348.....\$38.02



Spark Plug Indexing Washers

These washers are designed for use on all 14mm spark plugs with 5/8" hex. With three thicknesses in each package, one will correct the electrode placement on any plug and simplify the time consuming task of spark plug indexing. The washers are precision stamped from copper for perfect sealing and heat transfer. Use with tool MOR62160. 30 per package, 10 each size.



Tapered Seat, .010", .021", .032".MOR71900..\$19.39
Flat Seat, .043", .050", .064".....MOR71910..\$19.39

Spark Plug Indexer

It's designed for both flat and taper-seat 14mm spark plugs, enables selection of spark plugs that will not make such contact
MOR62160..\$11.07



ARP Spark Plug Indexer

By allowing you to consistently position spark plug ground electrodes out of harm's way, this takes the guess work out of installing spark plugs where the combustion chamber and high dome piston clearances is critical. Designed to fit in the palm of your hand, this tool eliminates the need to perform cylinder head calibration. Best of all, the ARP indexer is made from aluminum alloy with precision machined threads that allows you to proof the quality of spark plug threads before installation in expensive cylinder heads. Anodized for protection and quick recognition. For use with tapered gasket 14mm plugs.
ARP920-0001.....\$20.95

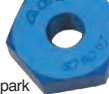

Float Adjusting Tool

Loosen. Adjust. Tighten. One Tool. Adjusting the float levels on any bicknell Holley style carb has never been so easy. This tool is the wrench and the screw driver all in one.
BRP9359.....\$44.57



Carburetor Work Stand

Maintenance Made Easy. This handy stand allows you to perform maintenance without damage or fighting with an unlevel carb on the bench. Allows stacking of carbs for easy storage. fits most 2 and 4 brl carbs.
BRP9358.....\$52.51



Push Rod Length Checkers

Proper push rod length is absolutely critical for peak performance - minimizing bent or broken valve stems, guide wear, and energy-wasting valve side-loading friction. May not be legal for sale or use in California or on any pollution controlled vehicles.

Product Fits: 1955-86 Chevy All Models

3/8" Studs, S/B.....ROC66789.....\$10.63
7/16" Studs, S/B.....ROC66790.....\$10.63



Universal Valve Lash Adjusting Tool

This tool is like having 16 valve lash adjusting tools in one. It configures to adjust all shaft & stud mount rocker systems on the market today. Now you don't have to buy a new valve lash adjusting wrench for each different rocker system. Just snap on the appropriate std 1/2" drive socket,insert the correct hex key and you are good to go. It is designed with the correct length to easily tighten down any adjuster nut & makes breaking loose stubborn adjusters easy.
LSM1T-100...\$69.81



Valve Lash Adjusting Torque Wrenches

It is a combination precision torque wrench and valve adjustment tool. It simplifies making precision valve lash setting by properly torquing adjuster nuts every time.
LSMTQ-100-3.....\$178.55



T-Handles

5/32".....LSM1T-5/32...\$3.98
7/32".....LSM1T-7/32...\$4.97



Dual Feeler Gauge Handle

Holds two sets of feeler gauges on the same handle. Perfect for intake and exhaust or go no-go gauges. Will accept various styles of 1/2" wide feeler gauges depending on your application. (gauges not included.)
LSMFH-200BL.....\$34.90



Single Wire Timing Light

This self-powered timing light is designed to work without an auxiliary power source which makes it ideal for use with magnetos, rear battery mount race cars, motorcycles, marine, go-karts and all spark ignition systems for single wire hassle-free timing. The Light is equipped with a xenon bulb, which generates a bright strobe, as well as a convenient work-light. State-of-the-art, single wire design (operates on 2 D cell batteries). Excellent for use with magnetos and all spark ignition systems. Bright xenon strobe clearly visible in daylight. Accurate timing up to 14,000 RPM. Can be used to test circuits.
FLAFR1001.....\$64.09



Self Powered Timing Light

It doesn't require 12 volts. This means less wires are hanging over the engine compartment and makes for quick, easy checks. For power, the Light uses six AAA batteries. The lightweight assembly is injection molded for great durability and produces an intense strobe that is easy to view through 5,000 rpm.
MSD8991....\$242.95



ENGINE TOOLS - BOTTOM END



Adjustable Ring Compressor

Putting the connecting rod through first, simply place the piston (with rings) into the tapered end of the ring compressor. Tighten the compressor snugly around the base of the piston. Then lay the compressor flat on the engine cylinder bore.

4.000"-4.090" Blue...ROC66766
4.125"-4.205" Gold...ROC66767
4.205"-4.310" Red...ROC66768
\$31.03

Piston Ring File

Proper end gap is imperative to performance. ROC66785...**\$58.02**

Rod Bolt Stretch Gauge

0.001 Dial indicator. Using the stretch factors supplied by rod bolt manufacturers, this stretch gauge offers a highly accurate way to measure torque pre-load. With a special, high-tension spring, this gauge remains conveniently positioned on the bolt during tightening, with adjustability for bolts up to 2.75" long.

ROC66788...**\$64.66**

Replacement 120-Grit Grinding Wheel

Optimize the performance of Piston Ring Filers ROC66785 with this replacement grinding wheel.

ROC66786...**\$10.63**

Stud Extracting Tool

Easily allows removal of stubborn studs, such as rocker or cylinder head studs.

ROC66796...**\$25.79**

9" Degree Wheel

Use this Degree Wheel to find top dead center or for checking camshaft timing.

ROC66791...**\$15.88**



Degree Wheels

They accurately measure several timing functions of an engine: camshaft centerline, valve timing, TDC, BDC, etc. Marked in easy-to-read one degree increments. Made from heavy gauge metal with a silk screen finish for long-lasting use.

11" Degree...MOR62190...**\$37.88**
18" Degree...MOR62191...**\$59.17**



Sportsman Degree Wheels

Multiple sized degree wheels provide precision and accuracy. Can be bolted on most harmonic balancers or used with a COMP crankshaft socket.

7.5" Sportsman...COM4787...**\$15.71**
9" Sportsman...COM4790...**\$17.99**
Replacement Pointer...COM4794...**\$1.81**



Crankshaft Socket Tool

Designed to simplify the task of crankshaft rotation during short block assembly with the balancer removed. Manufactured of tool quality steel with gold iridite finish. Accepts 1/2" drive.

MOR61760...**\$32.25**



Crankshaft Socket Tool for Degree Wheel

Moroso Crankshaft Socket Tool, engine builders have a positive way to turn over the engine, to locate TDC and BDC when degreasing camshafts. Broached keyway allows the socket (which fits 1/2" drive) to slide over the crankshaft snout and key. A knurled jam nut is then used to position a degree wheel.

SB and 90° V6 Chevy, Super Duty Pontiac/GM 4 Cylinder
MOR61755...**\$66.55**

Harmonic Balancer Installation Tools

It has adapters to fit most popular engines including Chevrolet, Ford, Mopar, KB Hemi, Pontiac, Oldsmobile and Buick. Or choose from several tools designed for specific engine applications. Each tool uses a pilot stud, which keeps the harmonic balancer perpendicular to the crankshaft's centerline for a bind-free installation. Thrust bearing and protective washer allows the drive nut to rotate freely so the balancer is pressed on smoothly and evenly.

It includes screw-in inserts for 7/16", 1/2", 5/8" and 3/4" threaded openings
MOR61744...**\$86.40**



Camshaft Installation Handle - Universal

Universal handle includes five interchangeable adapters that fit most domestic V6 and V8 engines, including Chevy, Ford, and Chrysler V8s.

COM5311...**\$65.86**

16" Professional Degree Wheel

It is machined from a thick aluminum plate, red anodized and precision engraved. The open design allows degree bushing changes while the wheel is still on the engine.

COM4791-1...**\$217.21**

Universal Camshaft Degree Kit

(Cylinder Heads On Engine)

Kit complete with necessary components to degree a camshaft. Available for most popular engines. Ships in a foam lined plastic carrying/storage case.

COM4796...**\$160.57**

Harmonic Balancer Installation and Removal Tool

Innovative tool with multiple adapters installs and removes harmonic balancers quickly and easily without causing damage. 4 heat-treated chrome moly inserts fit most popular engines including Chevy, Ford, Mopar, KB Hemi, Pontiac, Oldsmobile & Buick.

MOR61743...**\$225.08**



Engine Cleaning Brushes

It's important to have a clean block - especially in critical hard-to-get-at areas of the oiling system. Each brush is designed for a specific purpose; there are two each of the oil gallery brushes since they get the most wear.

MOR61820...**\$36.15**

Engine Storage Bag

Manufactured from heavy 4 mil thick plastic. Extra-large size covers a complete engine including most headers. 1 per pkg.

MOR99400...**\$9.21**

ARP Rod Bolt Extensions

A long taper and full radius prevents nicking and scratching of crankshaft journals during connecting rod installation. ARP rod bolt extensions act as a guide during piston and rod installation.

5/16".....ARP910-0001...**\$39.98**
3/8".....ARP910-0003...**\$39.98**
7/16".....ARP910-0004...**\$42.69**
Set of 3.....ARP910-0005...**\$117.38**

Tapered Ring Compressors

CNC-machined from 6061-T6 billet tube material and feature a true radius for each different bore dia.

4.000.....ARP900-0000...**\$58.16**
4.030.....ARP900-0300...**\$58.16**
4.040.....ARP900-0400...**\$58.16**
4.060.....ARP900-0600...**\$58.16**
4.125.....ARP900-1250...**\$58.16**
4.135.....ARP900-1350...**\$58.16**
4.155.....ARP900-1550...**\$58.16**
4.280.....ARP900-2800...**\$61.53**
4.310.....ARP900-3100...**\$61.53**
4.470.....ARP900-4700...**\$61.53**
4.500.....ARP900-5000...**\$61.53**
4.560.....ARP900-5600...**\$61.53**
4.600.....ARP900-6000...**\$61.53**
4.625.....ARP900-6250...**\$61.53**
78.00mm...ARP901-7800...**\$61.29**
95.00mm...ARP901-9500...**\$61.29**

Oil Pump Primer Kits

This lets you spin the oil pump with a drill motor and bring up the oil pressure prior to starting the engine. ARP's rugged primer shafts are rated at 170,000 psi to ensure extended service life of this valuable tool. They feature a special billet aluminum sleeve that accurately positions the shaft and keeps it from wobbling.

SBC & BBC & 90° deluxe, 9.00" O.A.L.
ARP130-8802...**\$50.62**
SBF, 1/4" hex drive
ARP150-8801...**\$46.75**
351C, 351W, 351M, 400, 429/460,
5/16" hex drive
ARP150-8802...**\$46.75**



Crank Sockets

SBC, 90° V6, and GM 4 cylinder 1.255" ID with 3/16" Keyway
COM4793...**\$34.50**
BBC - 1.610" ID with 3/16" keyway
COM4797...**\$41.58**

Crank Gear Installation Tool

Cams Crank Gear Installation Tool is used in conjunction with COM4920 Harmonic Balancer Installer, equal and constant pressure is applied, and the chance of gear damage is minimized.

COM4789...**\$27.76**



Universal Cam Bearing Installation Kit

Range from 1.125" to 2.690" journal diameter. Kit includes five expanding neoprene covered mandrels, a centering cone, extension rod and fitted plastic case.

COM5312...**\$284.61**

Camshaft Installation Handle w/Hardware

These simple, yet effective handles provide good leverage and a non-slip grip when installing or removing a cam.

COM4919...**\$50.63**

Univ. Harmonic Balancer Installation Kit

Univ. Kit fits all domestic and most foreign engine applications. Utilizes thrust bearing to gently ease the harmonic balancer onto the crank snout. Eight interchangeable adapters include: 7/16", 1/2", 9/16", 5/8", 3/4", 12mm, 14mm, and 16mm.

COM4920...**\$52.14**

2-in-1 Harmonic Balancer Puller Installation Kit

"Must have" for serious engine builders. Features a hardened threaded shaft with alloy nut combined with a roller thrust bearing puller plate. Included various size puller bolts and most uses. Kit fits GM, Ford, Chrysler crankshafts. Black oxide finished with storage box.

COM300...**\$150.26**

Oil Pump Primer

Both models feature a top alignment collar and Chevy model includes a bushing to pressurize the upper valve train.

Chevy V8...COM4921...**\$30.09**
Ford 260-351W 1/4".....COM4922...**\$31.29**

Oil Pump Primers

Remove the dist & insert the primer to engage the end of the oil pump drive. The other end fits a 3/8" chuck in a hand drill to drive the oil pump.

Fits Ford 289, 302, 390, 428 engines. Pump drive end of the primer fits 1/4" hex male end of the oil pump drive
MOR62210...**\$14.63**
Fits Ford 351W, 351C, 400, 429, 460 engines. Pump drive end of the primer fits 5/16" hex male end of the oil pump drive
MOR62220...**\$14.63**

ENGINE TOOLS - TESTING

Cylinder Leak Down Gauges



• The most accurate way to check your engine
• Set piston at TDC and turn air on. Set the left gauge to 100 psi and read the difference in the right gauge
• If the leakdown is excessive, listen to the carb, header, or crank vent to see where the problem is works on any engine from kart to big block
• Awesome for crate engines!!!
• STD 14mm spark plug fitting included

Gauge with Standard Gauges.....BRP9238\$121.64

MOROSO

Cylinder Leakage Tester



Quickly diagnoses failed or leaking valves, pistons, rings, and head gaskets. Large-diameter 3-1/2" gauge face indicates percentage of leakage rather than psi, eliminating need for math calculations. Includes 4-foot hose with quick-disconnect fitting and two zinc-plated adapters for 14mm and 18mm plug sizes. Use with MOR89602-Adapter for Leak Tester.

Cylinder Leakage Tester, Standard Version MOR89600.....\$151.32

Longacre

Engine Leak Down Tester - 12 mm



Quickly tell - from the outside - when your engine needs an overhaul! This easy-to-use tester checks ring seals, valves, even head gaskets. Don't wait too long to rebuild that expensive motor - but don't do it too soon either! Allows the ability to achieve consistent power. Stretch out the time between costly teardowns. Rugged design features rubber bumpers to protect the gauges. Exclusive Longacre gauge manifold meters the airflow for precise readings. 12 mm plug adapter.

LON73011.....\$111.62

Digital Engine Leak Down Tester - 12 mm



Don't wait too long to rebuild that expensive motor - BUT don't do it to soon either. This easy-to-use tester checks ring seals, valves, even head gaskets. Much more accurate than traditional testers - Reads critical leakdown to .5% (1/2 of 1%). Gauges have back lights for easy readability and low battery indicators. 12 mm spark plug connector and hose included. Control inlet valve avoids shock to gauges when air is turned on, allowing more accurate readings, easier use and longer gauge life. Rugged design features rubber bumpers to protect gauges. Silver carrying case included.

LON73015.....\$204.69

Engine Leak Down Tester



Quickly tell - from the outside - when your engine needs an overhaul! This easy-to-use tester checks ring seals, valves, even head gaskets. Don't wait too long to rebuild that expensive motor - but don't do it too soon either! Allows the ability to achieve consistent power. Stretch out the time between costly teardowns. Rugged design features rubber bumpers to protect the gauges. Exclusive Longacre gauge manifold meters the airflow for precise readings.

0-3000 lbs. by 1 lb. Travel to .001". 6" to 20" tall springs. Coil and coil-over springs, square end and "pigtail". Includes easy-to-use digital indicator to measure spring travel and a digital load readout.

LON73010.....\$111.62

Valve Spring Removal Tools



We developed the standard for changing valve springs with our innovative designs. The LSM Spring Removal Tools are simply the best quality & easiest to use. It makes changing valve springs a fast & simple one-man job.

LSM makes every effort to stay current with the latest designs from the rocker manufacturers, however rocker designs may change. Please consult our factory if you have questions about a particular rocker design and whether or not LSM has a tool to fit.

LSMSC-100

- Small Block Chevy w/Jesol, T&D
- Buick w/Jesol
- Dodge W-8 w/Jesol
- FE Ford - Jesol only
- Chrysler Indy 440-1 head w/Jesol
- Barton Hemi exhaust only w/slight modification

LSMSC-100.....\$198.50

Valve Seat Pressure Testers



Adjustable On-Head Valve Spring Pressure Tester for various shaft and stud mount roller rocker systems. It comes equipped with a 0-600 lbs. liquid filled gauge. It features four coarse adjustment hole locations and includes fine adjustment shims to enable calibration to within .050 of rocker arm pivot length. Includes set-up and adjustment guide.

LSMPC-100.....\$228.43

The Slant/Convertible handle lends itself better to space constraint situations. It can be used in either a straight (conventional) handle position or a slanted configuration. The handle is a two piece handle and the top can be removed for additional clearance.

Available thru Special Order.
LSMPC-100SLC.....\$248.38

Conversion Kit to convert a standard PC-100 into a Slant/Straight handle option.
Available thru Special Order.
LSMSL-001.....\$38.90

Low-Profile Design Valve Seat Pressure Tester



Similar to MOR62390 shown above with low-profile design to fit under windshield and cowl of tube-chassis cars. Designed by Jerry Haas, the tool features a rocker arm "gripper" machined from billet aluminum. Scale reading from 160 to 400 lbs. allows testing of springs with higher spring pressures. Use in conjunction with Moroso Stud Mount Valve Spring Compressor MOR62370 to maintain valvetrain

MOR62391.....\$115.74

Valve Seat Pressure Tester

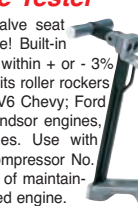

The ultimate tool for checking valve seat pressure on an assembled engine! Built-in 300 lb. reading scale is accurate to within + or - 3% with no need for math conversions. Fits roller rockers on Small Block, Big Block and 90° V6 Chevy; Ford 221-302, 351-400 SVO and Ford Windsor engines, and most other wedge-type engines. Use with Moroso Stud Mount Valve Spring Compressor No. 62370 for the most accurate method of maintaining the valvetrain on a fully assembled engine.

MOR62390.....\$95.48

Stud Mount Valve Spring Compressors



Between-rounds valve spring changing is greatly simplified with this tool. Unlike models offered by other manufacturers, Moroso's stud mount tool fits both 3/8" and 7/16" rocker studs and is much stronger in the handle area to withstand the pressures of today's "extreme high pressure" valve springs. The 12" handle gives all the leverage needed to compress the strongest springs

MOR62370.....\$110.61

Stud Mount Valve Spring Compressor Conversion Kit. Contains all parts necessary to convert MOR62370 to fit Jesol Rocker Shaft Valve Springs.

MOR62372.....\$68.40

PROFORM

Vacuum Pressure Gauge



Perfect for a variety of automotive tests (except parallel parking!) including fuel pumps and intake manifolds. Easy-to-read gauge with 30 vacuum and 60 lbs pressure. Each gauge comes with gauge, hose small brass cone and large rubber cone.

ROC67410.....\$21.03

Dual-Gauge Leakdown Tester



Measures condition of head gaskets, piston rings and valves.

ROC68639.....\$71.40

Stud Mount Valve Spring Compressor



Fits all 3/8" and 7/16" rocker studs. This handy tool from Proform simplifies the task of removing the valve springs from an assembled engine. The long lever handle makes it easy to press down on the valve spring so that the keepers can be removed, and then slowly release the tension on the spring.

ROC66784.....\$54.91

Valve Spring Pressure Tester



Need to check spring pressure at the track? No problem with the PROFORM stud style valve spring compressor. This fully adjustable tool fits easily onto your rocker arm for pressure checks and will measure pressure up to 600 lbs.

ROC67597.....\$250.39

Mini Valve Spring Tester



Here's the affordable, portable way to test springs. The hex-design body is very versatile: use it in a vise or an arbor press. These hydraulic models are supplied complete with a recalibration feature and a rubber gauge protector.

0-700 x 10 lbs.....ROC66834.....\$81.94
0-300 x 10 lbs.....ROC66835.....\$81.94

Remote Starter Switch



No more jumping from under the hood, to the front seat, to under the hood! Easily test your engine with the PROFORM Remote Starter Switch.

ROC67406.....\$15.70

12V Circuit Tester



Quickly check any 6 and 12 volt system with power on to locate shorts, grounds, and open circuits.

ROC67408.....\$15.66

Heavy Duty Manual Compressor



Our super-duty compressor is constructed of a welded steel box-tubing frame and an over-counter type clamping device that can compress any valve spring. The compressor arm slides up and down for adjustment and utilizes a locking pin for speed and ease of use. A base is offered to hold the unit upright in order to use the compressor in conjunction with a mini spring tester. A small engine and motorcycle model is also available.

COM5333.....\$209.15

ENGINE TOOLS ASSEMBLY



BR Break-In Oil

Used by Joe Gibbs Racing to break-in and dyno all their engines, this petroleum oil provides the highest levels of Zinc and Phosphorus for flat-tappet engines. The additive package promotes ring seal & provides max protection available for cams and lifters during initial break-in. Good for 2 hours dyno time & requires no additional additives.

15w50JGR00106...\$7.99
5w30JGR01806...\$7.99



Assembly Grease

Unique formula completely dissolves in oil leaving no residue. Used to pre-lube cams and lifters. Application to ring land prevents micro welding during initial engine break-in. Combined with Joe Gibbs Driven BR, it provides proven protection during break-in.

JGR00728...\$22.99



Automotive Degreaser

Professional strength formula foams away dirt, grease, and oil from all automotive parts and surfaces. Safe for use on any washable parts including rubber and plastic. Use for any degreasing need in your shop.

JGR50010...\$5.39



Brake and Parts Cleaner

Quickly removes brake fluid, grease, oil and other contaminants from brake lining and drums. Dries Fast. Leaves no residue. Non-Chlorinated. Excellent general parts cleaner.

JGR50020...\$4.49



Performance Engine Assembly Lube

Blended for all automotive and industrial applications. Eliminates galling, blueing, metal transfer and oil starvation during break-in. Consistency of warm honey. Dramatic cam and valve train life guaranteed. Not a moy paste. The choice of Champion Engine Builders.

4 ozPROB4040\$8.05



Engine Break-In Oil Additive



Extend the durability of internal engine components, including camshafts, lifters, and all valve train components. Special blend of extreme pressure additives no longer available in off the shelf motors oils. Provides added protection during critical engine break-in process. Compatible with any petroleum, synthetic or blended motor oil.

12 oz. BottleCOM159...\$10.48



Cam and Lifter Installation Lube

Initial start-up is the most critical time in the life of any new camshaft. This is the instant protection you need to guard against any premature wear.

8 oz. Bottle.....COM153.....\$10.09



Assembly Lube

It is a specialty, film forming lubricant designed to protect moving components & wear surfaces during assembly and initial break-in. Prevents metal-to-metal contact upon startup before adequate lubrication is supplied and offers excellent rust and corrosion protection during long service periods and storage. Fully formulated with high levels of anti-wear & extreme pressure additives and surface active chemistry to reduce friction. Non-foaming.

MAX69-01904.....\$9.95



Waterproof Grease

Multi-purpose lithium complex grease. Excellent resistance to water washout and clings to metal surfaces under the most severe condition, will not thin out. Use on all motorcycle, ATV, PWC, trailer and snowmobile components. Saltwater resistant. Provides excellent protection against high loads, extreme temps, moisture, rust & corrosion. Very high temp grease suitable for disc brake apps. NLGI #2.

16 oz. JarMAX80916\$8.95



MPPL Multi-Purpose Penetrant Lube

It is a superior, all-purpose spray-on penetrating lubricant. Provides a light lubrication and excellent barrier against rust and corrosion. Great for displacing moisture or loosening corroded nuts and bolts. Film forming protectant for metal surfaces and will not harm plastic or painted surfaces. Excellent fogging oil and starting fluid for engines.

14.5 oz. AerosolMAX73920.....\$8.95



Engine Assembly Lube

The choice of prof engine builders for its superior lubricating properties and its exceptional ability to adhere to internal engine parts until start-up. This white lithium base lubricant is ideal for the ball socket area of rocker arms and removes with soap and water for easy clean up.

8 oz. Jar.....COM104.....\$6.82



Engine Assembly Lube

Premium grade Moly base with rust and corrosion inhibitors. Effective lubrication range: -30°F to 750°F. Load range: 500,000 psi. Designed for use with bolts.

(0.5 fl. oz.).....ARP100-9908\$1.67
(1.69 fl. oz.).....ARP100-9909\$8.02

Thread Sealer

PTFE based with rust and corrosion inhibitors. Effective range: -30° to 550°F. Sealant range: 10,000 psi (pressure). Application: delivers a flexible leak-proof seal in aluminum, steel, stainless steel and plastic against coolants, water, gasoline, natural gas and LPG. Designed for use with bolts.

(1.69 fl. oz.).....ARP100-9904.....\$10.49



6" Dial Calipers

Ok, so maybe you're not a machinist. But if you want to talk to your machinist about deck height, clearances, end play or just about anything else, these are essentials for your tool box. It's also a good idea to check parts before you assemble that trick race engine. Complete with protective case.

BSC90110.....\$24.95

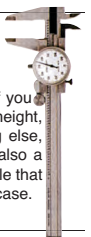

3 Piece Machinist's Set

6" dial calipers, 6" stainless ruler and a 1" micrometer in a foam lined case.

BSC90100.....\$40.95



Line Wrenches

-3.....QUA200-3071...\$14.08
-4.....QUA200-3072...\$14.08
-6.....QUA200-3073...\$14.08
-8.....QUA200-3074...\$14.26
-10.....QUA200-3075...\$15.03
-12.....QUA200-3076...\$15.12
-16.....QUA200-3077...\$16.56
-20.....QUA200-3078...\$16.78
-6 thru -16 Kit.....QUA200-3070...\$69.50



Drip Tray

Helps keep your shop floor clean during disassembly. Fits most 3 and 4 leg engine stand. Stand not included.

JAZ720-000-01.....\$47.18

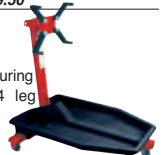

Engine Lift Plate

Gold anodized plate fits std Holley 4150/4160 and 4500 Dominator, Rochester Quadrajct, Carter, Motorcraft, Edelbrock, Edelbrock Q-Jet and Carter AFB carbs.

ALL10123.....\$12.99



Engine Lift Plate

Fits Holley or Quadrajct bolt pattern manifolds. Easily drilled for other patterns.

MOR62670\$30.98



Caps and Plugs

Allstar Caps and Plugs are a must for keeping debris out of lines and hoses. Ideal for keeping internal components of dry sump pumps, fuel pumps, pressure regulators, etc. clean during storage. Caps and plugs fit 37 degree flared fittings and straight threaded ports. Available in plastic and aluminum.

Plastic Caps 20-Pack

3ANALL50801\$3.69
4ANALL50802\$3.79
6ANALL50803\$4.19
8ANALL50804\$4.49



Plastic Caps 10-Pack

10ANALL50805\$3.49
12ANALL50806\$3.99
16ANALL50807\$4.69

Plastic Plugs 20-Pack

3ANALL50811\$3.79
4ANALL50812\$3.99
6ANALL50813\$4.79
8ANALL50814\$4.99



Plastic Plugs 10-Pack

10ANALL50815\$3.59
12ANALL50816\$4.29
16ANALL50817\$4.39

Aluminum Caps 20-Pack

3ANALL50821\$7.99
4ANALL50822\$4.49
6ANALL50823\$6.39
8ANALL50824\$7.89



Aluminum Caps 10-Pack

10ANALL50825\$5.49
12ANALL50826\$5.99
16ANALL50827\$7.99

Aluminum Plugs 20-Pack

3ANALL50831\$9.99
4ANALL50832\$5.99
6ANALL50833\$5.99
8ANALL50834\$8.59



Aluminum Plugs 10-Pack

10ANALL50835\$5.69
12ANALL50836\$7.99
16ANALL50837\$10.39

ENGINE TOOLS



Compression Tester

Tester checks cylinder compression from 0-300 PSI and features an air-hold valve to reset gauge. Two brass fittings with o-rings are included for 14mm and 18mm spark plug threads. Easy to read 2-1/2" dial is encased in a metal housing with a 12" flexible hose attached.

ALL96520\$24.99



Rod Guide Tool

Plastic tool slips over 3/8" or 7/16" rod bolts to aid piston installation and eliminate the chance of rod bolts hitting crank. A must for any engine builder's toolbox.

3/8" Rod Guide ToolALL96480\$22.99
Rod Guide Tool Extension for BB ...ALL96481\$13.79



Valve Spring Compressor

Adjustable C-clamp style compressor will fit most heads including Hemi. Spring cup will fit stock springs up to 1.750" diameter. Compressor has 9/16" hex for use with a wrench, ratchet or impact. This tool will handle spring pressures in excess of 1200 lbs. without slipping off.

ALL96490\$199.99



Spark Plug Indexing Tool

Indexing positions the ground strap of the spark plug properly for best piston dome clearance and unshrouds the electrode for a more even burn and possible gains of 5-15 hp. Works with flat gasket or taper seat 14mm spark plugs.

ALL96510\$18.99



Perfect Launch Drag Racing Tree

The Perfect Launch reaction timers feature a remote thumb trigger, .4 and .5-second pro and full trees, and an adjustable delay box, bump down, & rollout. (4.5 in. x 2.75 in. x 1 in.)

ROC67025C...\$62.04

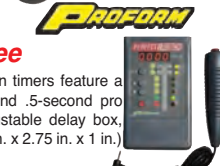

Weather Pack Crimp Tool with Crimp Dies

Use with weather pack connector kits Ratchet style crimper insures a positive connection. Fast and easy.

LON4905...\$111.60



Variable Speed Intercomp Shock Dynamometer, 40" Masts

Dynamometer Specs: 3HP Motor. 3HP Variable Speed: 0.5 to 19 in/sec. Adjustable Stroke: 1.0", 1.5", 2.0" or 2.25". Type K Thermocouple Sensor. Runs on 220V Power. Scotch Yoke System. 2,000lb Load Cell. USB Connection. Compression/Tension Load Cell

Software Features: User Friendly, Easy-to-Operate. Load & View Previous Shock Tests. Overlay 20 graphs. Display all measurement units independently. Force:lb/kg. Distance: in/cm. Temp: °F/°C. Warm Up for Time or Temp. Test by Time or Temp. Live Data Display/Live Graphing Option. Real-Time PVP Graphing with CVP Graphs for Each Velocity Interval. Peak Velocity Pick Off Testing/Graphing (PVP). Constant Velocity Testing/Graphing (CVP). View Data Points in 0.1", 0.5", 1.0" Or 2.0" Intervals. Export Data to Excel. Customized Logo on Printouts. Seal Drag Test. Gas Test. Compatible with Windows 2000, Windows XP, Vista, Windows 7, Windows 8, Windows 10.

INT102093-40...\$8645.00



Spark Plug Gap Tool

To set consistent plug gaps, insert plug into holder, put feeler gauge between ground strap and electrode, and gently turn the knurled knob until feeler gauge is snug.

ALL96515\$159.99



Internal Thread Chaser

Insert tool past damaged threads and, using undamaged threads as a guide, twist back out to restore damaged threads. The 14mm tool is perfect for repair of damaged spark plug threads without removing cylinder head.

14mmALL96434\$51.99



Main Cap Removal Tool For LS Series Engines

Quickly and easily pull main bearing caps of GM LS series V8 engines, especially those with main studs. Hook tool to the bottom of cap, press down on handles, and the balanced leverage pulls the cap out of the block with one swift motion. 26" long x 4" high.

ALL96525...\$219.99



Laser Scale Pad Leveler

If you don't level your scale pads your "accurate setup" goes out the window! This easy-to-use system helps you level each pad, then helps you bring all 4 at the same height - to closer than .050". First use the level vial to accurately level all 4 scale pads. Next turn the laser on, put it on top of 1 pad (this is your baseline pad) & point it at another one. Put the measuring tab on this pad and slide it sideways until one of the white dots shows brightest in the laser beam. That dot is marked how much higher or lower it is than the baseline pad. Raise or lower that pad until the dot at Level shows brightest.

LON72977\$89.99

Legend Car Adapter

(metric) 19 mm x 1.5
Adapter screws onto spindle.

LON78445.....\$47.97



Oil Filter Cutter

While it may be a lousy thing to find metal particles in your oil filter, it's a worse thing not to find them. Metal in your filter can warn you of impending problems with bearings, thrust surfaces or a host of other broken parts. Know about it before it's too late by using this oil filter cutter, and get a progress report on your engine's health every time you change the oil.

QUA200-3060.....\$37.89



Telescoping Magnet

A strong (3 pound pull), telescoping magnet that will retrieve unreachable dropped tools or fasteners. Tool extends over 2 feet, and retracts to just 5" to fit in a shirt pocket.

ALL14173.....\$3.99



Telescoping Mirror

A 1-1/4" multi-positional, telescoping mirror for inspecting hard-to-see areas or locating engine oil leaks. Mirror is 6-1/2" long and extends to over 19".

ALL14174.....\$2.99



3 Piece Freeze Plug Driver Set

Have problems installing freeze plugs? Use these plastic drivers for simple installation without damaging the plugs or the block. Three sizes per kit: 1-1/2", 1-5/8", 1-3/4".

ALL96482.....\$49.99



Cam Bearing Installation Tool

Tool is a must when installing cam bearings in SBC. Install bearings quickly and easily without damage. Shaft is steel; pilot and driver are aluminum.

ALL96470..\$31.99



Pulley Shim Kits

WP shims have dual bolt hole pattern to fit most GM and Ford WP. Crank pulley spacers are for SBCs. Each kit includes 3 shims, 1/16", 1/8" and 3/16".

ALL31066\$16.99



Brass Freeze Plug Kit

Eliminate any chance of rusted out freeze plugs with Mr. Gasket's Brass Freeze Plug Kit. Though designed for marine applications, kits are ideal for long-term stored vehicles as well as every day street use. Kit includes all plugs needed for a complete engine.

SBCMRG6481\$25.45

BBCMRG6482\$29.89

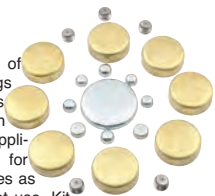

Oil Filter Cutter

Joe's Racing Products has designed a new Oil Filter Cutter that allows you to quickly check your spin on filter for debris. The Joe's cutter works with all popular filters and comes complete with an adapter bushing to fill the oversize hole of larger filters like the HP6. The adapter keeps the cutter centered versus fumbling around with an undersized bushing that lets the cutter flop around. Replacement blade available.

JOE21000...\$79.95



Portable Engine Heater

This 110V Aluminum Portable Engine Heater is designed to pre-heat the water system prior to engine start up by heating and circulating water through the entire cooling system and engine block. Use Coolant Check Valve (10016600-1) to connect heater to cooling system.



KEY10016600....\$850.00
*Special handling charge.

Coolant Check Valve

Used to ensure directional water flow through the entire cooling system. Lightweight aluminum designed to fit current radiator plumbing and to work with the Portable Engine Heater (10016600).



1-3/4".....KEY10016600-1...\$195.00
1-1/2".....KEY10016600-12...\$195.00

3/8 NPT Quick Disconnect Fittings



Female.....KEY10016600-V.....\$48.21
Male.....KEY10016600-X.....\$33.25

High Torque Tire Siper Attachment

For use on the Standard Electric Tire Prep Stand (KEY430 TPS005-C) and the High Torque Electric Tire Prep Stand (430 TPS005-C-HT). Heim mount provides smooth and precise siping motion. (Van Alstine Tire Siper, part #1007336, sold



KEY430TPS003-E-12...\$69.95

High Torque Tire Wrap Attachment

For use with the High Torque Electric Tire Prep Stand (430 TPS005-C-HT). Convenient swing away arm and adjustable tension knob provide a fast and easy way to shrink wrap tires. *Needler assembly required (430 TPSNDLR).



KEY430TPS004-E-HT...\$149.99

High Torque Tire Prep Station Cart

Tire prep stand/cart for use with the high torque electric tire machines (Wide 5 Part# 430 TPS016-HT and 5X5 Part# 430 TPS016-HT5X5).



KEY430TPS005-C-HT...\$329.00
*Special handling charge.

High Torque Electric Tire Prep Machine (Wide 5)

High torque electric tire rotator for Wide 5 applications. Knob controlled variable speed motor can rotate in either direction. Hands free foot pedal control. A tire prep cart/stand is available separately (430 TPS005-C-HT). Accessories sold separately. Accessories include: Needler Assembly (430 TPSNDLR-HT), Tire Wrap Attachment (430 TPS004-E-HT), Tire Siper Attachment (430 TPS003-E-12), Grinding Tool Holder (430 GRI009-E), and Siping Iron Holder (430 HTI007-E).



KEY430TPS016-HT...\$1195.99
*Special handling charge.

High Torque Needler Assembly

For use with the high torque electric tire prep machine, wide 5 (Part# 430 TPS016-HT).

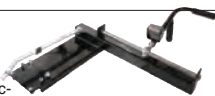

KEY430TPSNDLR-HT...\$450.00



Intercomp

SW777RFX Wireless Professional Scale System

Fully Integrated RFX Wireless Technology. Encryption Ensures Secure Wireless Communication. USB & RS232 Output. Certified to 0.1% Accuracy of Applied Load, or ± 1 Graduation, Whichever is Greater. 1,500 lb (700 kg) Pad Capacity. 6,000 lb (2,800 kg) System Capacity. Weights Displayed on RFX™ Wireless Indicator & in RaceWeigh Software Simultaneously. Stores 100 Chassis Setups. Baseline Setup Recall. Center of Gravity Calculation. User Selectable Display Modes. Target Tune Feature. Giant 0.5" Display Characters. View ANY Combination of Scale Pad Weight & Percentage. 400hr Average Battery Life in Pads.



INT170127-WPC....\$1895.00



Intercomp PERCENT WEIGH™

Quik Weigh SW650RFX Wireless Scale System

Displays Setups to One Hundredth of a Percent! Fully Integrated RFX Wireless Weighing Technology. Encryption Ensures Secure Wireless Communication. USB & RS232 Output. Certified to 0.1% Accuracy. 1,500 lb (700 kg) Pad Capacity. 6,000 lb (2,800 kg) System Capacity. Stores 100 Chassis Setups. Baseline Setup Recall. Center of Gravity Calculation. User Selectable Display Modes. Target Tune Feature. Giant 0.5" Display Characters. Backlit for Low-Lighting Conditions. View Any Combination of Scale Pad Weight and Percentage



System Includes:

15" x 15" x 2.5" Wireless RFX Billet Pads. One-Touch Wireless Indicator with Rechargeable Batteries, Battery Charger & Case. AA Alkaline Batteries for Scale Pads. 2-Year Warranty.

INT170126-W....\$1695.00



Intercomp

2.5" Scale Pad Leveler with Roll-Off Pad

Set of Four (4) Designed to Fit Any 15" (381mm) Scale Pad with 2.5" (64mm) Pad Thickness. Enables Cart to be Rolled On & Off the Scale Pad with Little Effort. Aluminum Construction. Dimensions: 31" x 15.5" (787 x 395mm)



INT170133....\$995.00

Scales and Equipment Digital Laser Leveling System

- Level Pads, Roll-Offs or Setup Racks
- Laser Sighting with a Virtually Unlimited Range
- Compatible with All Scale Systems
- Includes Case



INT102018\$259.00

Scale Cart

High Quality Cart with Wheels. Strong and Lightweight. Carries all Four Pads, Cables, and Controller. Accommodates both 2.5" (64mm) and 4" (100mm) Profile Pads. Dimensions: 20.63" x 21" x 41.5". This strong yet lightweight scale cart is a convenient way to store and transport virtually any brand of electronic corner weight scales using standard 15" x 15" scale pads. Each slot is sized to accept either a standard 4" or a low-profile 2.5" pad. The covered top compartment houses your scale controller and cables with room to spare. Place the controller on top of the cart for a convenient, waist-high stand. The quick-release handle stows underneath the cart, so you can store the cart under a workbench until it's needed.



INT100346.....\$369.00

15" x 15" Scale Pad Leveler - Set of 4

Set of Four. For any 15" x 15" (381 x 381mm) Scale Pad with a 2.5" (64mm) or 4" (100mm) Profile. High-Quality Steel Construction with a Powder Coat Finish. Dimensions: 15.5" x 15.5" (395 x 395 mm).



INT100344....\$519.00



Tire Roller

Now you can check stagger, sipe, groove, inspect, and clean tires without chasing them all over the pits. You can adjust the width for different tire sizes and break it down for easy storage. JOE32200 ..\$83.95



Dial Durometer

Dial Shore A Durometer has a flat base and easy to read numbers helping you to get the best tires out of the stack. Be sure to visit our website and check out the JOES Knowledge Center for Tech that gives you the secrets for proper Durometer use. JOE56020 ..\$52.95



Precision Digital Durometer

Digital Durometer features easy to read large numbers. Digital resolution is far superior to old dial type designs. A hold button holds your reading on the display for easy viewing. A foam lined case protects your investment. Serious racers that want to track their Durometer readings closely will enjoy the accuracy and .5 readout. JOE56015 ..\$73.95



Intercomp

Combination Digital Leak Down/Compression Tester w/Case

- Repeatable Accuracy for Engine Cylinder & Fuel Injector/Barrel Valve Leak Down Percentages
- Reads to 400 PSI
- Locking Regulator Allows Incoming Air Pressure Adjustment
- Intake Air Pressure and Hose Length will not affect readings (Must have 90 PSI input Pressure)
- Meets FAA Standards for Leak Down Testing Engines up to 5.00 Inch Bore
- Optional Hoses Available



System Includes:

- 14mm Leak Down Hose
- 14mm Compression Hose
- INT170134.....\$845.00

Coil-Over Spring Rater and Compressor

Intercomp's Coil-Over Spring Tester and Compressor tests coil springs, coil-over assemblies (including 5th coils), rod pressure, bump stops and coil bind to a load capacity of 5000 lbs; truly a multi-purpose tool.

- Rates Standard Coil Springs 2.5" (64mm) to 6" (152mm) Diameter
- Rates Coil-Over Setups
- Compress Coil Over Assemblies for Easy Adjustments
- Increased Height of 31" (787mm) Eye to Eye
- 10 5/8" (270mm) Jack Travel with 12" (305mm) Digital Travel Indicator
- Rate Bump Stops and Determine Coil Bind and Rod Pressures
- Easy to Use Handles Allow Adjustments without Tools
- Capacity: 5,000lb (2,500kg)



INT110060\$1820.00



Professional Tire Gauge

One of the most important, if not the most important thing on your vehicle is your tires. The detail that goes into a set of race tires and the amount of money spent on them should be backed up with accurate pressure inside them. If you are concerned about measuring tire pressure accurately, then you need a JOES gauge that can do the job for years to come. JOES has been obsessing over every little detail of our Precision-Air Tire Gauge and has spared no expense to make sure that it has the highest quality components available. Every gauge comes certified to guarantee its accuracy and it can always be re-calibrated if something should happen to it in the future. JOE32311 ..\$650.95



Go Pro Mount

JOES new GoPro Tube Mounts are the stable aluminum option that you've been waiting for. No more need to buy plastic versions that won't hold up to racing conditions. Our mounts are solid, eliminating vibration, and swivel for easy positioning.



Go Pro Mount

3/4"	Go Pro AssemblyJOE60076\$146.95
7/8"	Go Pro AssemblyJOE60081\$146.95
1"	Go Pro AssemblyJOE60086\$146.95
1-1/8"	Go Pro AssemblyJOE60091\$146.95
1-1/4"	Go Pro AssemblyJOE60096\$146.95
1-3/8"	Go Pro AssemblyJOE60101\$146.95
1-1/2"	Go Pro AssemblyJOE60106\$146.95
1-5/8"	Go Pro AssemblyJOE60111\$146.95
1-3/4"	Go Pro AssemblyJOE60116\$146.95
2"	Go Pro AssemblyJOE60121\$146.95



Tube Mount Only

3/4"	Tube Mount OnlyJOE60075\$51.95
7/8"	Tube Mount OnlyJOE60080\$51.95
1"	Tube Mount OnlyJOE60085\$51.95
1-1/8"	Tube Mount OnlyJOE60090\$51.95
1-1/4"	Tube Mount OnlyJOE60095\$51.95
1-3/8"	Tube Mount OnlyJOE60100\$51.95
1-1/2"	Tube Mount OnlyJOE60105\$51.95
1-5/8"	Tube Mount OnlyJOE60110\$51.95
1-3/4"	Tube Mount OnlyJOE60115\$51.95
2"	Tube Mount OnlyJOE60120\$51.95



Swivel Assembly

Go Pro Swivel AssemblyJOE60025..\$104.95

Digital Angle Gauge with Magnetic Base and Sides

- Locate Angles Digitally
- Large LCD Display
- Magnetic Base and Sides
- Reads from 0°-90° in 0.05° Increments



INT102144.....\$69.00

Smart Tool



It can be used to ensure that chassis tubing is level and plumb, and comes in helpful when building roll cages or checking driveshaft angles. Features of the SMARTTOOL include a "hold" button which allows "freezing" and "unfreezing" readings which can be displayed as degrees, percentages (slope), or in./ft. (pitch) at the push of a button. Pitch readings are in 1/8 in./ft. increments. An on/off switch will shut the tool off auto if it's left idle for more than 6 mins. Powered by a standard 9 volt battery. ALL10113...8" Smart Level.....\$114.99



Intercomp

Analog Shock Inflation & Pressure Gauge

- Measures Pressure in PSL and Bar
- Pressure Range of 0-300 PSI and 0-20 Bar
- Liquid Filled
- Measured in 10 lbs. PSI Increments and 1 lb Bar



Tire Durometer

- Adjustable Face to Zero
- Type A Removable Tip
- Reads from 0-100



INT360092.....\$59.99

Tire Durometer / Tire Tread Depth Gauge Set

INT360110.....\$99.95



Digital Shock Inflation and Pressure Gauge

- Allows Quick and Easy Pressure Settings to 300 PSI (21 Bar)
- 0.5 Increments
- Selectable in PSI, Bar, Kg, & CM2
- Compatible with Most Shocks
- Thumb-Operated Bleeder Eliminates the Need to "Crack the Seal" to Achieve Desired Pressure
- Comes standard with "Schraeder" Valve Adapter for the Penske-Style Valve
- Needle adapter for Ohlins-Style Valve is Available



With CaseINT100675\$545.00
Adapter for Needle Valve...INT100678\$69.00

Billet Digital Depth Gauge

- Measures Depth in 0.0005" and 0.0127mm Increments
- Depth Range of 0-0.25" (0-6.35mm)
- Zero Accuracy of ± 0.001
- Billet Aluminum Base Construction
- Four Point Cad/Cam Design
- Large 0.5" Digital Display
- Includes Case



INT102081.....\$249.00

Tire Tread Depth Gauge

- Measures Tire Wear in 1mm and 1/32" Increments
- Alum. Construction - Pouch



Digital Fill, Bleed, and Read Air Pressure Gauge

- 0-150 PSI (0-10 BAR)
- Readout in 0.1 Increments
- Delivers Unsurpassed Accuracy via the Digital Controller
- Selectable in PSI, BAR, and Kg/Cm2
- Available with Ball or Angle Chuck



With Case (Reads to 150.0 PSI) INT360094.....\$399.99

With Ball Chuck INT360094-BC.....\$399.99



150 PSI Digital Air Pressure Gauge

(Factory Certified) This ultra quick, high accuracy, digital gauge is the choice of professionals in all types of motorsports. Easy-To-Read, 0.5" display Reads to 0-150 PSI in 0.1 Increments High Accuracy PSI, BAR, kg/cm2 Keypad Calibration Push button Zero Peak Hold Thumb-Operated Bleed-Off 22" Goodyear Hose 45-Degree Swivel Chuck Backlit Display for Night Use. Includes: Case



With Ball Chuck (Reads to 99.99 PSI) INT360045.....\$299.99



Digital Caster/Camber Gauge with AccuLevel



Here's a super accurate digital caster / camber gauge that reads to .1° (1/10°) camber and caster as high as needed, and at a price any serious team can easily justify. It comes with our latest Super Magnetic adapter and a padded silver carrying case. As an additional benefit the AccuLevel digital readout can be removed and used separately as a digital angle finder for suspension, spoiler angles, and many other things.

Includes: Digital Caster/Camber Gauge, AccuLevel Pro Model with back light (removable). Super Magnetic adapter. Padded carrying case.
LON78290\$237.14

Digital Caster/Camber Gauge with AccuLevel No Adapter



Here's a super accurate digital caster / camber gauge that reads to .1° (1/10°) camber and caster as high as needed, and at a price any serious team can easily justify. Includes padded silver carrying case. As an additional benefit the AccuLevel digital readout can be removed and used separately as a digital angle finder for suspension, spoiler angles, and many other things.

Includes: Digital Caster/Camber Gauge, AccuLevel Pro Model w/back light (removable). Padded carrying case.
LON78291\$215.41

Digital Kart Caster/Camber Gauge with AccuLevel

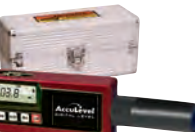

Here's a super accurate digital caster / camber gauge that reads to .1° (1/10°) camber and caster as high as needed, and at a price any serious team can easily justify. It comes with a kart adapter and a padded silver carrying case. As an additional benefit the AccuLevel digital readout can be removed and used separately as a digital angle finder for suspension, spoiler angles, & many other things.

Includes: Digital Caster/Camber Gauge, AccuLevel Pro Model with back light (removable). Kart adapter. Padded carrying case.
LON78292\$191.52



"Four Bubble" Caster/Camber Gauge

Check camber from +8 to -8 in 1/4 degree increments. Caster readout from +8 to -4 in 1/4 degree increments.

Bubble Gauge & Case OnlyQUA200-3300..\$99.95

Gauge & Magnetic adapter.....QUA200-3302..\$129.95
Gauge & GM adapter (3/4-20)QUA200-3304..\$119.50
Gauge & Wide 5 adapter (1 13/16-16).....QUA200-3306..\$119.50

Wide 5 adapter only.....QUA200-3400..\$22.50
GM adapter only.....QUA200-3401..\$24.00
Big Ford adapter only (13/16-20).....QUA200-3402..\$24.00
Pinto adapter only (3/4-16).....QUA200-3403..\$24.00
Stock Car Products Adapter (27/32-20).....QUA200-3404..\$38.32
Magnetic adapter only.....QUA200-3405..\$36.00
Kart adapter (5/8-18).....QUA200-3408..\$31.50

Digital C/C Gauge w AccuLevel and Quick Set Adapter

Here's a super accurate digital caster / camber gauge that reads to .1° (1/10°) camber and caster as high as needed, and at a price any serious team can easily justify. It comes with our QuickSet adapter and a silver carrying case. **Includes:** Digital Caster/Camber Gauge, AccuLevel Pro Model with back light (removable), QuickSet adapter, Silver carrying case.

Quick Set Adapter

The fastest way to check your front end alignment. Just hold it against the rim for easy, accurate readings. No spindle adapters required here. Made from CNC machined billet alum. Works on virtually any car, any size wheel. 3 point design makes setting caster easier. Folds for easy storage.
LON78295.....\$291.85



AccuLevel Pro Model Digital Level

Back light for dark places under car. Measure suspension and spoiler angles and lots more. Reads to .1° +/- from 0 to 90°. Simple to use, easy to read, accurate. Can be quickly field calibrated to maintain accuracy. Used in our Digital Caster / Camber gauges. Comes with silver carrying case. Dimensions - 6-9/16" x 1-1/4" x 2-3/16".
LON78311.....\$116.27



Chassis Height Measurement Tool

Works in 3 Different Ways. Car on the ground - measures chassis height directly, accurate to 1/16". Indicator shows height as the car moves up and down. Use set of 4 to quickly see height at all 4 corners. You don't even need to bend over. Measures height from 2" to 10" (higher if needed).
24" for perimeter frames.
ShortLON78320\$115.48
36" for straight rail cars on right side.
LongLON78325\$127.03



Aluminum Turn Plates (pair)

Free floating in 2 directions eliminates bind. Reads to 1/2° - Degrees can be zeroed with the car on. Low profile, only 1" tall.
LON79800.....\$898.50



Quick Toe Setting Tool

Here's a quick and accurate way to set toe. Mounts on the wheel to avoid errors. You can even attach a caster camber gauge to either side (use LON78291 Digital Caster/Camber Gauge with AccuLevel less adapter). Similar to our QuickSet Caster/Camber gauge adapter. Magnets in the legs hold it to your steel wheel - one on each side. Makes setting toe a quick 1 person job. Eliminates tire "bulge" error. Includes set of 2 fold-up fixtures, 2 tapes and silver carrying case.
LON79630.....\$316.75

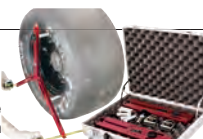

Bump Steer Gauge

It comes complete with dial indicators and everything you need to check with wheels on or off the car.
Drilled....QUA200-3030.....\$129.00
Blank....QUA200-3031.....\$129.00



Caster Camber Gauges

Fully adjustable to fit any steel hub or wheel. Measures from -7 to +7 degrees w/1/8 degree accuracy.
Hub TypeQUA200-3010\$45.38
Rim Type.....QUA200-3020\$39.95



Intercomp Toe Plates

Set of 2. Two high strength, lightweight, aluminum plates for quick, easy, and accurate toe measurements.
• Dimensions: 27.5" x 11"
• Quickly & Accurately Measure Toe
• High-Strength, Lightweight, Aluminum Plates
• Includes Two Measuring Tapes
INT102009.....\$99.00



Single Wire Timing Light



This self-powered timing light is designed to work without an auxiliary power source, which makes it ideal for use with magnetos, rear battery mount race cars, motorcycles, marine, go-karts, and all spark ignition systems for hassle-free timing. "The Light" is equipped with a xenon bulb which generates a bright strobe as well as a convenient work-light. Durable construction includes a rubber encased lens and 48" pickup lead. Longer leads are available for industrial applications.
• State-of-the-art single-wire design (operated on two D-Cell batteries)
• Excellent for use w/magnetos & all spark ignition sys
• Bright xenon strobe clearly visible in daylight
• Accurate timing up to 14,000 RPM
• Can be used to test circuits
FLAFR1001.....\$64.09



Pro Timing Light



It is constructed with solid state circuitry and uses a Silicon Controlled Rectifier (SCR) that provides accurate and stable timing signals from 0 to 8,000 rpm. This rugged timing light is built to work in rough environments such as racing pits or professional mechanic shops. It is injection molded for great durability and produces an intense strobe that is easy to view even in daylight. The battery clamps are color-coded and insulated for tight, safe connections.
• Detachable Leads. • Secure pick-up.
• No retard as RPM Increases.

MSD Powered Timing LightMSD8992\$182.95

Self-Powered Timing Light



An accurate timing light is extremely important to the performance of your engine. It is a tool every per tuner should have. A great feature of the Self-Powered Timing Light is that it does not require 12 volts. This means less wires are hanging over the engine compartment and makes for quick, easy checks. For power, the Light uses 6 AAA batteries. The lightweight assembly is injection molded for great durability and produces an intense strobe that is easy to view through 5,000 rpm. The inductive pick-up is detachable for easy storage.
• Battery powered.

Self Powered Timing Light.....MSD8991\$242.95
HarnessMSD89911\$75.67

Single Channel Digital Ignition Tester



Hand held tester generates a trigger signal to check the operation of MSD single channel igns and the coil (6, 7, 8 and 10 Series Ign Controls) LCD display shows the simulated RPM and can be used to confirm the operation of rev limits, rpm activated switches, shift lights and tachs. Additional circuit will check the operation of cam sync signals. Triggers through breaker points, amplifier and magnetic pick-up trigger inputs from the MSD Ign. Can be used on 4, 6 and 8-cyl engines. This Tester will check the operation of all of MSDs single-channel CD Ign Controls. Once the ignition tests good, you can continue troubleshooting and find the culprit. It produces a simulated trigger signal that fires the ignition just as if the engine was running.
MSD8998.....\$303.95

TIRE AND PIT

Pitman Impact Gun **Longacre** w/ Battery & Charger

True portability, no air hose to trip over. High torque 24 volt - pops lug nuts off easily. 1/2" drive, 2 long lasting batteries, fast charger. 2600 impacts/min., 2000 RPM free speed. Carrying case included. With 2 Battery Chargers.....LON68604.....\$289.99



Pit Guns

Durable Allstar 60/40 ratio air impact guns have twin hammer impact mechanisms, side exhausts & billet reverse buttons. Std impact gun is perfect for the Sat night racer. The Deluxe version has a steel forward-reverse valve and is highly modified for 10,000 RPM operation & quick pit stops. Manifold for use w/ 2 Regs.....ALL10438\$57.99



Manual Bead Breaker

Heavy steel bead breaker makes it easier to dismount tires. With 15" arm BSC90400...\$49.95



Tire Bead Breaker

Durable steel construction with rubber hand grips. Wide jaw bead breaker works well with soft sidewall tires. For use with 15" wheels. Standard ...ALL10105.....\$43.99 Wide Jaw ...ALL10106.....\$46.99



Tire Spoons

Steel Tire Spoon will separate tire from rim after breaking tire bead with Allstar Bead Breaker. Straight Tire Spoon 24"ALL10103.....\$31.99 16-1/2" Curved Tire Spoon...ALL10104.....\$33.99



Econo Quick Spin Lug Wrench

Affordable lug wrench consists of a 1" dia tube with a shallow 1" socket welded to one end and rotating piece of plastic pipe attached to the other. The 10" handles are angled with rubber grips and the overall length is 23". ALL10108.....\$37.99

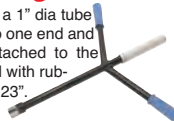

Glueless Lug Nut

Open end lug nuts attach to the wheel with springs for faster pit stops! Kits contain 5 glueless lug nuts with springs attached & self-tapping screws for mounting.



5/8"-18 Thread (Fine), 5-PkALL44107...\$39.99 5/8"-11 Thread (Coarse), 5-PkALL44108...\$39.99 Replacement Spring & Screw, 5-Pk.....ALL44109...\$15.69

Tire Sander

Extends life of used tires by removing a thin, hardened layer of rubber. Heavy duty 7" Milwaukee sander has a 0-6000 adj RPM range, to compensate for varying tire hardness, and features a 10 ft. detachable cord. Backing pad and discs are sold separately.



7" Tire Sander ALL44185.....\$269.99

4" Dia., 23 Grit, 5/8" HoleALL44180...\$42.99 7" Dia., 16 Grit, 7/8" HoleALL44182...\$58.99 7" Dia., Nail Head Disc, 5/8" Hole ...ALL44183...\$59.99 8" Dia., Nail Head Disc, 5/8" Hole ...ALL44196...\$95.99 7" Backing Pad Kit.....ALL44186...\$45.99

Short Pit Sockets

Tough impact sockets designed to instantly kick out the lug nut. Short.....BSC90405...\$25.95



Impact Sockets **Longacre**

Tough impact sockets designed to instantly kick out the lug nut. Short.....LON68525...\$57.62 LongLON68526...\$61.22



Pit Socket

Thick walled socket with 6 point surface-contact and large chamfer insures fast, clean engagement on the lug nut. Manufactured of alloy steel and carefully heat treated for max strength and prevention of lug nut damage. Accepts 1/2" drive, and fits 1" lug nuts. MOR62010.....\$54.61

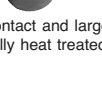

Van Alstine #1 S-100 Heated Tire Siper

Ergonomic Design. Fast - Sipes Easily With Multiple Blades. Holds Up To 13 Blades. Variable Blade Spacing. Cuts Open Sipes & Small Grooves. Accurate - Cuts With Control & Visibility. Instant Blade Change and Adjustment.



S-100 Heated Tire GrooverVANS-100\$199.00 Replacement Lever.....VANG-1000-LA/D.....\$11.95

V100 Tire Groover

"V" Series Tech minimizes size, maximizes cutting capability. Innovative blade holder. Insert, change and adjust blades with incredible ease. Tremendous, unobstructed visibility. 6 power levels. Power to match the job. Fingertip controls. Glides over the tire surface. Un-parallelled control. VANV100.....\$379.00

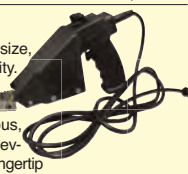

The Van Alstine blades for the V100 will also work with the discontinued G-1000 Tire Groover.

Flat Bottom Blades (12 Pack)

#3VANVF-3...\$12.99 #4VANVF-4...\$12.99 #5VANVF-5...\$12.99 #6VANVF-6...\$12.99 #8VANVF-8...\$12.99

Round Bottom Blades (12 Pack)

#1VANVR-1...\$17.50 #2VANVR-2...\$12.99 #3VANVR-3...\$12.99 #4VANVR-4...\$12.99 #6VANVR-6...\$12.99 #8VANVR-8...\$12.99



Tire Groover

Includes 12 pack of knives. Tire GrooverIDE-125-250\$81.95



Spare Knife Sets

#2 roundIDE-BL-02RD\$8.25 #3 (5/32) round.....IDE-BL-03RD\$8.25 #3 (5/32) square.....IDE-BL-03SQ\$8.25 #4 (7/32) round.....IDE-BL-04RD\$8.25 #4 (7/32) square.....IDE-BL-04SQ\$8.25 #5 (9/32) round.....IDE-BL-05RD\$8.25 #5 (9/32) square.....IDE-BL-05SQ\$8.25 #6 (3/8) square.....IDE-BL-06SQ\$10.85

Grooving Heads

#1 grooving headIDE-HD-01\$19.58 #2 grooving headIDE-HD-02\$11.24 #3 grooving headIDE-HD-03\$11.24 #4 grooving headIDE-HD-04\$10.51 #5 grooving headIDE-HD-05\$10.51 #6 grooving head.....IDE-HD-06\$16.10 #12 grooving head.....IDE-HD-12\$16.10



6 Blade Tire Sipers

Sipers quickly and precisely sipe tires for better traction. Units have adjustable sipe depth. Lightweight tool uses standard utility blades and is constructed for heavy duty use. These tools should be handled with care. ALL10265.....\$93.99



Tire Siper

Cutting tires for added traction is easy with this handy tool. Push tool across tire; no heat required. Includes #4 head and blade. ALL10109\$33.99

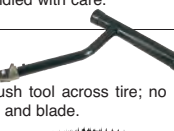

Traction Grabber for Low Powered Grinder

When std 8" traction grabber is used with the new grinding head it gives you more control to let you push harder on the tire. This added force is harder on the grinders & can burn it out faster. The solution was to make a 6" disk instead of an 8" disk to take some load away from the grinder. Same great results, just a little easier on the motors. Also helps the weaker models perform better. 6"BRPBRTTG-6\$82.50 8"BRPBRTTG\$85.80



Steel Lug Nuts

5/8"-11 steel (course) ..LUG010C ...\$1.00 5/8"-11 steel (course) ..LUG010HC.\$1.25 5/8"-18 steel (fine).....LUG010HF.\$1.00

Wide 5 Wheel Stud 5/8 Coarse

5/8" x 11.....WIL230-10989..\$2.24 **willwood**



Pack of 10

Aluminum Lug Nuts

Double Sided (Hardcoated)

Large open end, double chamfered aluminum lug nut fits 1" sockets. Lug nut has popular 5/8"-11 coarse threads and is hardcoated for added durability. Will not pull through the wheel. Sold pack of 10. ALL44097\$22.49



Steel Lug Nuts Pack of 10

Large diameter open end lug nuts will not pull through the wheel when tightened. Choose from steel or aluminum, SAE or metric threads. Nuts fit a 1" socket. Sold pack of 10. 5/8-11 Steel Coarse Double ..ALL44098...\$19.99 1/2-20 Steel FineALL44102.....\$9.99 7/16-20 Steel FineALL44100.....\$9.99 12mm-1.5 Metric.....ALL44101...\$12.99

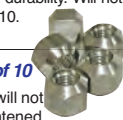

Stagger Tape

10' x 1/4" PowerLock Pocket Tape Rule with Dia Scale. 1/4" wide blade. Back of blade provides scale that measures up to 3' dia. STA33-115...\$6.57



Tire Tape Measures

Ten foot long tapes are ideal for measuring tire diameters & checking stagger. ALL10111.....\$4.99



Valve Core Tool

Made from Stainless Steel. 3" Long JOE32100 ...\$12.95



Tire Purge Tool w/ Adj Bleed Valve

Clips on to Valve Stem for Attended or Unattended Use Slide Valve Collar Opens Up for Fast Air Dumping to Purge Tires in Record Time. Bleed Valve Allows Automatic Drain to the Desired Pressure. JOE32125 ...\$73.95



Silver Tire Marker

Keep track of tires or anything else that you would use a silver marker on. It works great on tires because of the high contrast. JOE32145...\$5.95

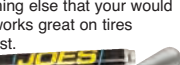
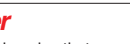

Valve Core Tool

Easily remove and install new valve cores. Base of handle has a machined pattern to aid with grip. Ergonomically designed and crafted from stainless steel. Measures 3" in overall length. ALL44030.....\$11.99



Compact Valve Core Tool

Alum body, steel tip. Put on your key chain for quick access. LON50272...\$6.23



Valve Core Stem Tool

Conveniently stores valve cores in the handle. Durable aluminum with stainless steel tip. Includes 3 spare cores. LON50270...\$18.62



Tire Marking Stick

Use on hot or cold tires, wet or dry. LON50880...\$4.67

Tire Marking Paint Pen

Finer line. Silver paint won't come off from heat. LON50882...\$6.23



Tire Tool

It perforates tire surface for better traction. Steel roller is 2" wide with a series of 1/4" tall, straight pin rows. 5" wood handle. Use caution when handling and storing tool, pins are needle sharp. ALL10550.....\$124.99





Chassis Ride Height Gauge

Makes setting up your chassis much easier. No longer need to make that special tape measure glued to a stick. Pull the handle, slide it under the frame, release and read the height on the handle.

BRP9240\$94.85



Tire Prep Stand

Steel tire prep stand is a must when grooving, sipping, grinding or even cleaning tires. Bolts together, and the pivoting head eases tire mounting. A locking T-handle secures the head assembly. Can be used with 5x5 or Wide 5 wheels.

ALL10555\$189.99

Tire Prep Mount

Manual steel tire prep mount eases grooving, sipping, grinding or even cleaning tires. Special one-way bearings prevent "roll back" when grooving or sipping. Bolt to a wall stud or other solid surface. Can be used with 5x5 or Wide 5 wheels. ALL10562 wall swivel (sold separately) allows use at various angles.

Tire Prep Mount.....ALL10561 \$215.99
Swivel For ALL10561 ...ALL10562 \$104.99

Electric Tire Prep Stand

It eases grooving, sipping, grinding and even cleaning of tires. 2-way switch permits clockwise or counterclockwise rotation. Foot operated pedal controls tire rotation. A 110v access outlet is included for convenient plug-in of siper or groover. Stand will accommodate 5x5 or Wide 5 wheels.

Electric Tire Prep Stand...ALL10565 \$1150.00
Cart Only, For ALL10565 ALL10567 \$289.99

Grooving Iron Holder

Bkt bolts to electric tire prep stand ALL10565 and holds 2 Ideal style grooving irons.

ALL10568\$29.99

Tire Sander Holder

Bracket bolts to electric tire prep stand ALL10565.

ALL10569\$38.99

Wheel Studs

Larger-than-stock studs require redrilling of stock flanges. Check sanctioning body for wheel stud requirements. 1/2-20 X 2", 5-Pack.

ALL44110.....\$9.99

Wheel Studs Press-In

7/16"-20 x 2-7/8". .480" dia. knurl & quick start dog end, fits most late GM drum brake applications. Std hole size: .472" to .479".....MOR46150.....\$15.06
7/16"-20 x 2-7/8". .560" dia. knurl & quick start dog end, fits most late GM disc brake & early drum brake app. Std hole size: .552" to .559".....MOR46160.....\$15.06
1/2"-20 x 3". .615" dia. knurl & quick start dog end, fits most disc brake Fords front & rear & Chrysler front. Std hole size: .606" to .613".....MOR46180.....\$15.06
1/2"-20 X 3". .594" dia. knurl & quick start dog end, fits 79-03 Mustang. Also has flat on head for front hubs with ABS. Std hole size: .580".....MOR46185.....\$15.06
1/2"-20 x 3". .685" dia. knurl & quick start dog end, fits most Chrysler rear with 1/2" stud. Std hole size: .676" to .683".....MOR46190.....\$15.03
1/2"-20 x 3". .563" dia. knurl & quick start dog end, for use in 1/2" Frankland hubs.Std hole size: .554" to .561".....MOR46220.....\$17.43
5/8"-18 x 3". .672" dia. knurl & quick start dog end, for oval track applications. Std hole size: .663" to .670".....MOR46240.....\$26.53

Wheel Studs Screw-In Type

1/2"-20 x 3", fits all aftermarket axles with 1/2"-20 threads.....MOR46200.....\$20.29

Wheel Studs

ARP's heat-treated 8740 chrome moly wheel studs are a much-needed replacement for any car engaged in oval track or drag racing competition. They have a tensile strength of 200,000 psi and are able to easily handle the tremendous acceleration shock loads (shear) and lateral forces (elongation) found in racing. The studs are sold in 4 or 5 packs and are cadmium plated for extra durability. Nuts not included. Now available for all popular applications, including General Motors, Ford, Honda and Chrysler replacements, as well as for oval track racing and aftermarket street and strip axles.

Application	A Knurl Dia.	L1 UHL	L2 Knurl Length	L3 Nose Length	Thread Size	Part #	Price
Ford, rear disc brakes/Chrysler front	.625	3.500	.400	.437	1/2-20	ARP100-7703	\$42.11
Ford, front disc brakes, early	.618	3.050	1.000	.250	1/2-20	ARP100-7707	\$82.01
Late GM drum brake	.486	3.165	.420	.308	7/16-20	ARP100-7701	\$13.38
Late GM disc brake & early drum brake	.580	3.200	.300	.305	7/16-20	ARP100-7702	\$13.38
Honda replacement (96 & earlier) 4 pack	.485	1.850	.275	.350	M12 x 1.5	ARP100-7709	\$16.10
Honda Ext length (1996 & earlier) 4 pack	.485	2.850	.275	.350	M12 x 1.5	ARP100-7711	\$31.41
Honda Ext length (1997 & later) 5 pack	.485	2.850	.275	.350	M12 x 1.5	ARP100-7712	\$38.89
Subaru WRX	.565	3.000	.270	.350	M12 x 1.25	ARP100-7716	\$40.18
Aftermarket axles, 12 pt style head	none	3.470	none	.500	1/2-20	ARP100-7704	\$35.38
Speedway Eng, Pro 4 disc	.568	2.970	.710	.465	1/2-20	ARP100-7706	\$42.11

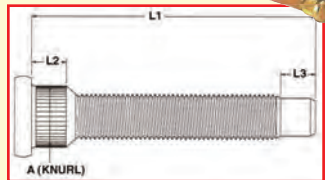

Quick Spin Lug Wrench

It is made of 7/8" dia tubing with a deep 1" socket welded to one end and a sealed bearing pressed on the other. Size: 18" w/ 7-1/2" handles.

1" Socket...ALL10107...\$48.99

Super Sockets w/Extension

They are available with 5" or 11" exts & include our Super Socket for fast wheel changes without jamming lug nuts. Sockets fit 1" lug nuts and are used with 1/2" drive impact guns.

11" With Extension ...ALL10241 ...\$74.99
5" With ExtensionALL10242...\$74.99

26" Tie Rod Socket w/Extension

A socket and a 26" ext in one tool, it may be used to check and tighten inner tie rod end bolts on most common racing rack and pinions. Extension has a 15/16" hex head socket and a 1/2" drive for easy use with any 1/2" drive ratchet.

ALL10243\$54.99

12 Pit Extensions Hex Socket

Developed to meet popular demand, extension is welded on. No more extensions slipping off. 1" Socket is 12" length. New design to clear beadlock ring on Weld Wheels.

ALL10240\$46.99

Spindle Nut Socket

Hex style socket fits Wide 5, Howe, Allstar and PCR 5X5 applications.

ALL10110\$27.99

Aluminum Wheel Adapter

Adapter bolts to stock 5x4-1/2" or 5x4-3/4" bolt circle hub and adapts to 5x5" bolt circle pattern wheel. Fitted with 5/8"-11 coarse thread studs. 1" thick.

ALL44128.....\$64.99

Aluminum Wheel Spacers

They fit 4-1/2", 4-3/4" and 5" bolt circle patterns. Spacers increase track width, requiring less wheel offset.

1/2" Alum Wheel.....ALL44121 ...\$19.79

3/4" Alum Wheel.....ALL44122 ...\$21.99

1" Alum Wheel Spacer ...ALL44123 ...\$24.79



Tire Claw

Traction Tools

It burns the pattern into the tire like a snow tire. The soft tire won't chunk because it is not breaking outside of the tread block. It uses a standard tire iron as it's hear source.

Chain Link Tread Pattern...BRP9354.....\$55.75
Block Tread Pattern.....BRP9355.....\$55.75

Tire Roll Out Fixture

Now you can check stagger in one place by chasing tires around the shop or pit area! Fits all tires from sportsman left fronts to modified right rears. Rubber feet on bottom keep it place - it won't slide around! Great gift for your best "TIRE GUY". Saves wrecking your best tape measure. Bolts and seals for rear end are not included****

BRP9241.....\$77.00

Longacre Pro-Team Tire Reliefs Kit

- 6 TIRELIEF valves
- 12 wheel adapters • 1 setting tool
- 1 inflation adapter

LON50100...\$258.28

Tire Pressure Relief

Use with quick change adapters or mount directly in your wheels by drilling a 1/8" NPT thread hole. 3-40 psi range. 100 mesh inlet filter to keep dirt inside tire from plugging Tirelief. LW alum only 9 grams won't affect wheel balance.

LON50000.....\$86.44

Setting Tool

Uses compressed air to accurately simulate tire pressure.

• 0-60 psi
LON50290.....\$48.05



Soft Mud Plugs

An economical way to prevent mud build-up inside racing wheels. Foam discs, in 3" and 5" thicknesses, install quickly and easily in 15" dia. wheels. Allstar logo is imprinted on one side.

Black.....ALL44150\$12.99

Red.....ALL44151\$12.99

Blue.....ALL44152\$12.99

Orange...ALL44153\$12.99

YellowALL44154\$12.99

Purple...ALL44155\$12.99





Shock Inflation Tool

Shock Inflator System allows you to adjust gas pressure in your shocks up to 200 PSI. A bleed valve quickly drops pressure so you can meter the pressure to match your desired results. Swivel fittings make it easy to connect the long hose while the shocks are on or off the car. Digital accuracy provides .1 resolution that cheap versions are unable to match. JOE19455\$188.95



Digital Caliper



Measure drill bits, bolts, sheet metal and tubing wall thickness, caster camber and bump steer shims, lots more. Reads by .0005" from 0.000" to 6.000". Easy-to-read digital display. Carrying case included. LON73007.....\$34.99



Basic Shock Inflator

Basic Dial Model. Reads to 300 psi by 5 psi. Easy to use. LON50493.....\$94.55



Durometer & Tread

Depth Gauge w/ silver case

Tire hardness changes as tires get older and even varies between new tires. Now you can keep track of exactly where your tires are. Reads from 0-100 points. Super accurate, easy to read, easy to use. Calibrated in 1/32" Accurate to 1/128" (less than .010") LON50556.....\$79.36

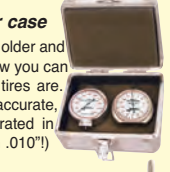

Aluminum

Stagger Gauge

62" to 115". Extra rigid ends. Tight tolerance square tube design for accurate results. Dual Scale - Easy to read with tires on the car or flat on the ground. LON50840.....\$76.85

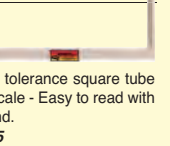

Dial Tread Depth Gauge w/Pouch

Super accurate, easy to read, easy to use. Calibrated in 1/32". Accurate to 1/128" (less than .010"). Comes with pouch. LON50560.....\$20.06

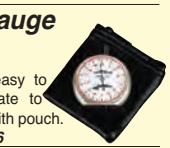

Infrared Laser

Pyrometer - 1400

• Reads to 1400 • Laser sighted • Back light for night use LON50615.....\$134.45



Dual Function Infrared

Laser Pyrometer

Plus Probe

Use as Probe type pyro for tires OR a non-contact infrared laser pyrometer. Accurate, fast response in either mode. 1400" range on IR. 500" range with tire probe. °F or °C switchable. Includes tire probe and silver case. LON50620.....\$211.22



Standard Memory

Tire Pyrometer

Displays 12 temps at once. 10 set memory. Coiled cord probe. Carrying case. Build Your Edge even more with Temp Averaging plus the bonus of a 4 car memory stopwatch with interval timing and more. LON50682.....\$383.76



Tire Pyrometer on a Tablet

Super fast response - takes temps quickly. 100 Memories shows memory temps with current. Exclusive "Anticipation Mode" speeds up process. 7" color Tablet (#50650) and wireless probe. Computes all tire temp averages, shows all at once. Includes the Tablet or you can use your scale Tablet. Easily switches from scales to pyrometer and back. Save money.



Includes 7" color TabletLON50650...\$568.82
Use your scale Tablet (or Smartphone)...LON50745...\$310.47

RACE RAMPS

Scale Ramps

They are used to roll your vehicle onto a 4 tire scale system. This product has a small incline with no platform. Light and solid, it does the job easily. A set contains 4 pieces. RARRR-SCALE.....\$169.00



Scale Ramps - 2 RR-SCALE-2

They assist a customer driving his or her vehicle onto a personal 2.5 inch high car scale set. This product has a small incline with platform. Light and solid, it does the job easily. A set contains 2 pieces. RARRR-SCALE-2.....\$95.00



Trailer Ramps

Simply place the door on the notch of these specially designed Ramps and decrease your angle of approach to as little as 4°. For cars weighing up to 6,000 lbs. Ideal for low ground clearance with extra wide tires. (Quantity 2)

46" l x 4" h x 14" w (5.5" incline)RARRR-TR-4 \$275.00
67" l x 5" h x 14" w (4" incline)RARRR-TR-5 \$317.00
45" l x 6" h x 14" w (7.8" incline)RARRR-TR-6 \$285.00
74" l x 7" h x 14" w (5.2" incline)RARRR-TR-7 \$384.00
54.75" l x 8" h x 16" w (8.4" incline).....RARRR-TR-8 \$317.00



Trailer Step RR-TR-SP-36

This portable step can be used as a free standing step for your trailer or around the shop to give you the added boost you need to get under the hood of that big rig!

24" l x 11" h x 16" w (Qty 1).....RARRR-TR-SP-24 \$179.00
30" l x 8" h x 11.25" w (Qty 1).....RARRR-TR-SP-30 \$169.00
35.5" l x 8" h x 11.25" w (Qty 1).....RARRR-TR-SP-36 \$179.00

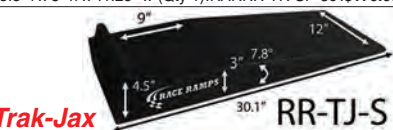

Trak-Jax

They are inspired to be an auto crosser that didn't want to buy a new, high priced, low-profile jack just to change his tires at the track. They get low cars up high enough to fit a std floor jack under the car. With or without a 1.5" stop.

30.1" l x 3" h x 12" w (with 7.8" incline) (Quantity 2)
Without 1.5" StopRARRR-TJ\$100.00
With 1.5" StopRARRR-TJ-S.....\$100.00

6" Brass Blow Gun

BSC80125.....\$9.00



6" Brass Blow Gun Bent End

BSC80126.....\$9.00



Long Style Air Hose

Coupler 1 piece per card

BSC80120.....\$4.80



Long Style Male Plug

2 piece per card

BSC80121.....\$1.20



Long Style Female Plug

2 piece per card

BSC80122.....\$1.20

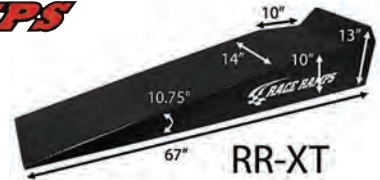

67" Race Ramps XTs

They are ideal for low ground clearance vehicles with tires up to 12" wide. With an incline of only 10.75°, they raise the car up 10" and hold up to 3,000 lbs per set while weighing only 15 lbs each.

67" l x 10" h x 14" w (with 10.75° incline)

1-piece (Qty 2)RARRR-XT\$317.00

2-piece (Qty 2)RARRR-XT-2\$363.00



56" Race Ramps

They are ideal for low ground clearance vehicles with tires up to 10" wide. With an incline of only 10.75°, they lift car up 8" and hold up to 3,000 lbs per set while weighing only 10 lbs per ramp.

56" l x 8" h x 12" w (with 10.75° incline)

1-piece (Qty 2)RARRR-56\$220.00

2-piece (Qty 2)RARRR-56-2\$247.00

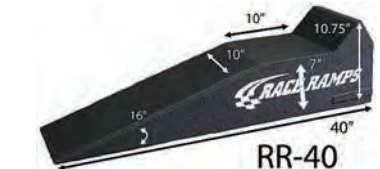

40" Sport Ramps

For small cars that don't have wide tires or low front ends, but who still want all of the other great Race Ramp features. Accommodating tires up to 8" wide and raising the car up 7". They hold up to 3,000 pounds per set while weighing only 8 lbs per ramp.

40" l x 7" h x 10" w (w/16° incline).....RARRR-40.\$148.00

Wheel Cribs

They cradle the tire 8", 10", or 12" off the ground (depending on the model), providing unobstructed access underneath the car. It supports 1,500 lbs (3,000 lbs per set) and weighs only 5 lbs. Using 8" or 10" Wheel Cribs in conjunction with 56" or 67" Race Ramps allows your car to be level while raised-useful for changing your oil, for example. Wheel Cribs also can be used for car display & are available in custom sizes.

15" l x 8" h x 12" wRARRR-WC-8\$105.00

15" l x 10" h x 12" wRARRR-WC-10.....\$110.00

15" l x 12" h x 12" wRARRR-WC-12.....\$125.00

Adjustable Wheel Cribs

Each crib comes as a stacked assembly of two interlocking pieces of equal height, their design allows the vehicle to be lifted in incremental heights that provide clearance for a jack and a spacer. Each set supports 3,000 lbs, yet each crib weighs only 5 lbs! They can hold tires up to 12" wide with diameters from 25" to 30". You can sue one set as either two 8"/10"/12" cribs or four 4"/5"/6" cribs when the set is split.

15" l x 8" h x 12" w (raise 4" or 8") (Quantity 2)

RARRR-WC-8-2.....\$137.00

15" l x 10" h x 12" w (raise 5" or 10") (Quantity 2)

RARRR-WC-10-2.....\$147.00

15.75" l x 12" h x 12" w (raise 6" or 12") (Quantity 2)

RARRR-WC-12-2.....\$179.00



Horizontal Air Tank

Tanks are equipped with a Quick Fill fitting to save you time. 1" 7" wide with an approx volume of 1176 cubic inches. JOE32450...\$115.95

Vertical Air Tank

28" high from base to handle. Approx volume 1685 cubic inches. JOE32452...\$125.95

Vertical Compact Air Tank

23-1/2" high from base to handle. Approximate volume 557 cubic inches. JOE32454...\$104.95

LW Polished Air Tank Only

Portable Ultra LW. Polished Air Tank w/Special Inlet Valve. Capacity: 5 US Gallons. Hose length: 4 feet with quick release. Approximate Size: 14" x 10". Max Pressure: 125 lbs. LON50316...\$150.17

Deluxe Racing Pyrometer

We covered with a rubber boot to protect and maintain accuracy. Oversize numbers are 1-1/2" tall with backlight. The auto shut off keeps the battery fresh. The 90° probe is compact to get into the fender well with ease. JOE54005...\$115.95

AccuTech Infrared

Laser Pyrometer - 600°

Instant response, non-contact temps. Back lites for night use. °F or °C. Laser sighting for accuracy. Holds readings longer for easier use. Measures to 600° F. LON50612...\$76.77

Infrared Memory

Laser Pyrometer

12 temp memory. Can be instantly recalled. Extremely fast and accurate. Reads to 1/10th degree. Reads fahrenheit or celsius. Laser sighting for accuracy. Back light for night use. Reads temps to 1000°. Storage pouch included. LON50614...\$159.90

AccuTech Econo Pyrometer

Accurate, fast response. Straight cord tire probe. 1400° range (with proper probe). °F or °C switchable. Less carrying case. LON50635...\$117.49

Wheel Dollies

Steel dollies are 14-1/2" wide x 23-1/2" long with std casters for use with cars weighing less than 2,500 lbs. Sold per pair. ALL10129...\$79.99

Pro1 Race Jack

Will it do what you need? Is its quality workmanship? Can you buy parts for it? Joe's can do all that! Made from quality USA materials. Weight: 36 lbs. with handle. 3600 lbs. capacity. Self bleeding system. Sealed hydraulics, no vent needed. Jack.....JOE55525...\$1095.95
Dirt Wings.....JOE55520...\$68.95

Jack Stands

It with unitized frame will support 3 tons. The ratchet locking mechanism assures safe, positive height control. Adjustable from 11-5/8" to 16-1/2". Sold in pairs. 3 Ton Ratchet Jack Stand ALL10124...\$29.99

Dirt Wing for Pit Jack

Provides a sturdy base when using the Pit Jack on a dirt surface. ALL10426...\$86.99

Air Jacks

Bert introduces an all aluminum bumper jack. It requires only 50 lbs of air pressure to reach full extension. Completely collapsible design for easy use and storage. Each level is equipped with safety locks for security and stability when setting up the car. Designed for race cars with bumpers such as IMCA, UMP, and New York modified. This Lightweight unit is 55 lbs. FrontBERAJ-1000-F.....\$1161.35
Rear.....BERAJ-1000-R.....\$1202.37

Tire Pressure Gauge

2-1/2" Glow-in-the-Dark

Internal gauge damper. Air pressure release button. 17" ultra-flexible hose with swivel chuck.

2-1/2" GID Tire Pressure Gauge	
0-15 PSI.....JOE32305	\$20.95
3-30 PSI.....JOE32306	\$20.95
5-60 PSI.....JOE32307	\$20.95

2-1/2" GID Tire Gauge w/Hold Fitting

0-15 PSI.....JOE32308	\$48.95
3-30 PSI.....JOE32309	\$48.95
5-60 PSI.....JOE32310	\$48.95

4" GID Tire Gauge w/Hold Fitting

0-30 PSI.....JOE32335	\$132.90
0-60 PSI.....JOE32336	\$139.95

Pro Tire Pressure Gauges

Swivel and angle chuck included. 2-1/2" glow in dark face: 17" rubber hose. Steel housing.

0-15 PSI Without Hold Valve.....JOE32315	\$28.95
0-15 PSI With Hold Valve.....JOE32325	\$46.95
0-30 PSI Without Hold Valve.....JOE32316	\$28.95
0-30 PSI With Hold Valve.....JOE32326	\$46.95
0-60 PSI Without Hold Valve.....JOE32317	\$28.95
0-60 PSI With Hold Valve.....JOE32327	\$46.95

Digital Tire Pressure Gauges

PSI setting can easily be changed to Bar. Includes chrome angle chuck and ball chuck.

0-60 PSI.....JOE32435	\$73.95
0-150 PSI.....JOE32436	\$73.95

Liquid Filled Tire Gauges

Glow in the Dark

2-1/2" Deluxe Gauge with protective bumper. 17" hose with swivel chuck. Holds pressure reading until released.

0-15 Angle Chuck.....LON52032	\$55.82
0-30 Angle Chuck.....LON52022	\$55.82

Glow-in-the-Dark Magnum Tire Pressure Gauges

Huge 3-1/2" Glow-in-the-Dark face for high accuracy and the easiest readability. High flow release button and swivel chuck. Holds pressure until released. Internal gauge damper for more consistent, accurate reading. Ultra flexible 17" hose. Comes with silver case.

0-60 psi 1 lb. Angle & Ball Chuck.....LON52001	\$79.05
0-30 psi 1/2 lb. Angle & Ball Chuck.....LON52021	\$79.05
0-15 psi 1/4 lb. Angle Chuck.....LON52031	\$79.05

150 PSI Digital Air Pressure Gauge

(Factory Certified) This ultra quick, high accuracy, digital gauge is the choice of professionals in all types of motorsports. Easy-To-Read, 0.5" display Reads to 0-150 PSI in 0.1 Increments High Accuracy PSI, BAR, kg/cm2 Keypad Calibration Push button Zero Peak Hold Thumb-Operated Bleed-Off 22" Goodyear Hose 45-Degree Swivel Chuck Backlit Display for Night Use. Includes: Case

With Ball Chuck (Reads to 99.99 PSI)
INT360045.....\$299.99

Aluminum Silver Stack Stands

Support stands can be stacked together to conserve valuable space in the trailer or the shop. Stands are 14" tall with a sturdy 12" x 15" base. Choose alum stands, rated at 3,000 lbs., or steel versions, rated at 3,500 lbs. Sold in pairs ALL10255...\$134.99

Warrior Alum Jack

Weighing in at only 32 lbs., these 3 and 6 pump jacks are available in black, red or blue.
3 Pump ..BRUBRI-0023 ..\$795.00
6 Pump ..BRUBRI-0026 ..\$795.00

Jack Accessories

From special side handles to dual return springs and NASCAR Winston Cup vents.

DIRT Skirt.....BRUBRI-185	\$79.95
DIRT Wings.....BRUBRI-184	\$59.95

Remote Tire Inflator, 60 PSI, Pro Gauge

Clip-On Style Air Chuck and 5 Ft. Rubber Air Hose provides a safe distance from the tire and wheel while the tire inflates. This new device also includes Quick Fill Inflator and our all new 60 PSI. JOE32486.....\$69.94

Quick Fill Tire Inflator

60 PSI. Chrome angle chuck installed. Quick Fill valve. Ball chuck included. 2.5" dial glow gauge

Tire Inflator Quick Fill Valve w/60 PSI JOE32485\$58.95

Tire Inflator Quick Fill Valve Only JOE32481\$37.95

Quick Fill Tire Inflator

It comes with a 17" hose with a 45° swivel chuck installed and a ball chuck for tight spots. Our 2-1/2" dia gauges glow it the dark.

Billet Quick Fill

0-30 PSI, Dial.....JOE32490	\$149.95
0-60 PSI, Dial.....JOE32491	\$149.95
0-60 PSI, Digital.....JOE32492	\$164.95
0-100 PSI, Precision-Air.....JOE32493	\$695.95

Tire Inflator w/Quick Fill Valve, 0-150 PSI

150 PSI 1% with a quick fill valve that inflates tires fast. Includes Chrome Angle Chuck & Ball Chuck for tight spots, plus 2 popular size fittings. w/60 PSI 1% Digital GaugeJOE32488\$104.95
w/150 PSI 1% Digital GaugeJOE32489\$104.95

Longacre

Dirt Tire Gauge: 0-25 PSI

Reads to .1 psi w/Angle Chuck.....LON53010.....\$127.66

Std Tire Pressure Gauges

Air pressure release button. Internal gauge damper for more accurate readings and longer life. 2" dial face. Ultra flexible 14" hose. Do not hold pressure.

Glow-In-The-Dark

0-30 1/2 lb. Ball Chuck.....LON52024	\$25.37
0-15 1/4 lb. Ball Chuck.....LON52034	\$25.37

White Face (Non Glow-In-The-Dark)

0-60 1 lb. Ball Chuck.....LON52004	\$25.37
------------------------------------	---------

Stock Car Jack Stands

They are stackable and have urethane pads to help keep your car from slipping. They are lightweight and stackable to save space in your trailer or the shop. 14" tall, sold in pairs. JOE55500...\$188.95

Tire Pressure Gauge Pouch

Unique pouch stores tire gauge on wall or other vertical surface. Stop wasting valuable time at the track searching for a tire gauge when it can be in an organized pouch at all times.

PIT228 Fits up to 3 3/4" Dia.....\$30.99
PIT227 Fits up to 3 1/8" Dia.....\$24.99

Aluminum Pit Jack

LW, 3,000 lb. capacity floor jack has a low profile to roll under the lowest slung race chassis. Made of high quality alum, jack incorporates a patented hydraulic system to reach max height of 17-1/2". Rolls easily on heavy duty rear caster wheels. Optional dirt wing adapts jack for use in unpaved pits. 3-Pump RedALL10422...\$529.99
6-Pump Silver.....ALL10425...\$479.99

Alum Pro Jack

It is made of billet aluminum and designed for max strength and durability. The Pro Series Jack is offered in 1-Pump, 2-Pump, and 3-Pump versions. The 1-Pump is available in many lifting configurations from 8" lift to 10-1/2" lift. The std colors are red, black, and blue.
1 Pump...BRUBRI-0041.....\$1395.00
2 Pump...BRUBRI-0042.....\$1395.00
3 Pump...BRUBRI-0043.....\$950.00



Axle Spline Tool

Tool clamps in a vise to hold 31 spline axles for maintenance or installation of axle plugs. Assures perfect spline alignment when installing lock-up plugs used with Gold-Trac differentials.

ALL66104 \$34.99



T-Handle Axle Puller

Tool includes adapters for fine or coarse 3/8" threaded solid axles, and 3/4" coarse threads for gun drilled axles.

ALL66115 \$29.99



Coil Mounts, Flat Mount

Lightweight, anodized aluminum bracket mounts ignition coil to chassis quickly and securely.

ALL81324 \$26.99



Tail Shaft Seal And Bushing

The tail shaft bushing is a regular wear item, located inside the transmission tail-shaft housing. It should be replaced when replacing a tailshaft seal or when a driveshaft failure has occurred. A worn bushing will cause excessive side-to-side movement of the slip yoke & create a vibration or leak. Bushing and seal fit GM Powerglide, Turbo 350, Saginaw, Muncie, Bert and Brinn trans.

ALL72152... \$9.99



Shop Towels

They are ideal for use in the shop.

Red Shop Towels, 25-Pack.....ALL12010.....\$8.99
White Terry Towels, 12-Pack...ALL12012.....\$8.99



Safety Glasses

Comfortable general purpose safety glasses have a clear wrap around lens for max visibility. ANSI-Z87.1 rated.

ALL10258 \$5.79



Individual Hole Saws

Hole Saw 0.750".....ALL10413 \$13.99
Hole Saw 1.000".....ALL10414 \$15.49
Hole Saw 1.125".....ALL10415 \$15.49
Hole Saw 1.250".....ALL10416 \$15.49
Hole Saw 1.500".....ALL10417 \$16.49
Hole Saw 1.625".....ALL10418 \$16.49
Hole Saw 1.750".....ALL10419 \$18.99



Toe Plates

Alum plates simplify setting of toe-in and toe-out. Plates fit against outside edges of tires. Deluxe plates have radiused edges, slots for narrow and wide tape measures and are 9" tall x 23" wide to work with vehicles with smaller wheel openings. Std plates are 1/2" thick, 11" tall x 32" wide and work well for vehicles with larger wheels and wheel openings. Set of 2 plates.

Std Toe PlateALL10117.....\$69.99
Deluxe Toe PlateALL10119.....\$54.99



Tie Downs, Straps And D-Rings

2" x 8" Tie Down (Flat Hook)ALL10184 \$28.99
2" x 8" Tie Down (Direct Hook)ALL10188 \$32.99
2" x 8" Tie Down (Twist Hook).....ALL10192 \$32.99



2" x 8" Tie Down with Built-In Axle Strap (Twist Hook)ALL10196 \$34.99
2" Wide Axle Tie Back Strap, 48" C/L to C/L of Hooks, Adj. 24"-40"ALL10200 \$18.99
21" Long Axle Strap.....ALL10204 \$10.99
33" Long Axle Strap.....ALL10208 \$11.99
HD Recessed "D" Ring.....ALL10210 \$8.69

Race Car Tie Down Package

Includes two ALL10196 Axle Combo Ratchet Straps and two ALL10200 Axle Tie Back Straps. Enough tie downs to secure one car to any trailer.
ALL10209 .. \$103.99



Spring Steel Punches

Spring steel punches place a 1/4" dia hole 1/2" from the end of Allstar's 1" x .062" thick spring steel material. Built-in stop positions material for accurate hole placement. ALL23116, placed on a hard surface, can be struck lightly with a 3 to 4lb hammer. ALL23117 may be placed in a vise, or hand-held and impact driven, using a 3/4" socket to punch spring steel mounted to race car.

Hammer Type PunchALL23116 \$167.99
Impact Type PunchALL23117 \$199.99



Round Tubing Notchers

Available in deluxe alum or economy steel versions, notchers auto align & center tubing and will accept up to 2" dia tubing. Use in drill press or with hand drill. Deluxe model adjusts up to 45 degrees in 1 deg increments. Econo steel notcher adjusts in 5 deg increments.

Aluminum.....ALL10400 \$279.99
Steel.....ALL10411 \$94.99



Replacement Parts For Round Tubing Notchers

Thread Adapter
1/2"-20 to 5/8"-18
ALL10402..... \$8.89

Arbor Support Bushings (1 pair)
ALL10403..... \$8.89

Arbor with 5/8"-18 Thread
ALL10405..... \$19.99

Drill Press Base For 10410
ALL10406..... \$42.99

Arbor Support with Needle Bearings
ALL10407..... \$46.99



Reusable Corded Earplugs

Corded earplugs fit instantly without rolling or squeezing. Made of a soft material that cleans up easily in warm, soapy water.

ALL12000 \$3.29



Ford 9" Set Up Carrier

Set up carrier takes the place of the gear set on Ford 9" rear end housings and will keep dirt and debris out of the housing. The tip of the handle matches the centerline of the drive shaft U-joint so drive shaft length can be easily measured.

ALL14169 \$66.99



Pinion Centering Jig

It locates pinion centerline and is useful when building or narrowing a rear end housing. Fits 9" Ford, 12 bolt Chevy, 8-3/4 Mopar, and Dana 60 rear ends.
ALL68370 \$45.99

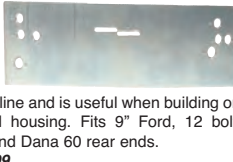

Bolt Extractor Kit

A power driven drill bit and an extractor in one tool. Use with a 3/8" variable speed reversible power drill to extract broken, rusted, stubborn bolts. No grinding or center punch required. Self centering tips work on jagged, uneven breaks. Four piece kit includes 1/4" (M6), 5/16" (M8), 3/8" (M10) and 1/2" (M12) bits.

ALL11050 \$44.99



Fine Thread Taps

Tungsten steel taps are titanium coated for long life. Taps are available in right-hand and left-hand threads.

ALL11066RH 5/8"-18 \$14.99
ALL11067LH 5/8"-18 \$14.99

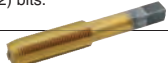

Punch And Flare Tool

Add strength and a smooth finish to hole edges. Unique tools can be used to punch and flare new holes, or to flare existing holes. Starting with a small center hole, the punch halves bolt together to cut and flare at the same time.

1-1/2" Punch And Flare ToolALL11070 \$97.99
1-3/4" Punch And Flare ToolALL11072 \$97.99
2" Punch And Flare ToolALL11074 \$106.99
2-5/8" Punch And Flare ToolALL11076 \$111.99



3/16" Double Ended Drill Bits

Double ended 3/16" bits are a must for every racer's toolbox. Package of 6.

ALL18204 \$6.99



13/64" Drill Bits

A common size bit for working with 3/16" flange type rivets. High speed steel bits have black oxide finishes and self centering tips. Flute length: 1-3/16", overall length: 2-1/4". Sold as a 2-pack.

ALL18203 \$5.79



Wheel Stud Drill Bit

43/64" bit is correct for drilling hubs or axle flanges to accept most 5/8" wheel studs with .690" knurl diameter.

ALL11045 \$10.99



Taper Reamers

Deburr or enlarge tapered holes to accept tie rods or ball joints. Reamer may be used in a drill with a 1/2" chuck by removing the T-handle.

7.15 deg., 1-1/2" Taper Per Ft. ALL11170 \$109.99
9.56 deg., 2" Taper Per Ft.ALL11172 \$139.99



Pilot Bushing Installation Tool

Special driver allows easy installation of pilot bushings or bearings.

ALL26115 \$22.59



Toe Gauge

Check toe quickly and easily. New design allows one person operation and the ability to check front and rear toe dimension from the front of the car without removing tool. Tool adjusts to measure from 49" to a max width of 89".

ALL10118 \$69.99



Set Up Stand

Check suspension angles and other measurements with the Allstar Set Up Stand. Before tire and wheel are removed, measure distance from center of hub to the ground and record.

Remove the tire and wheel, replace with the set-up stand, and adjust accordingly. Now adjustments can be made with the car at exact ride height with the wheel and tire out of the way. Sold each.

Set Up Stand, 5 x 5ALL10664 \$87.99
Set Up Stand, Wide 5ALL10666 \$87.99



Set-Up Plates

For accurate chassis set-up. Typically Set-Up Plates are used for squaring, stringing, and checking axle tubes for straightness. Eliminates wheel and tire differences.

Set-Up Plate 5 X 5ALL10660 \$95.99
Set-Up Plate Wide 5ALL10662 \$134.99

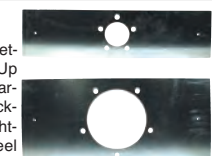



Wide Angle Mirrors

Easily fasten a mirror to your race car with our quality wide angle mirror kits. Bkts are billet alum & anodized black.

Wide Angle Mirror Kit With 1-1/2" Clamp

14" Mirror Kit w/Std BracketsJOE11272\$62.95
14" Mirror Kit w/5" BracketsJOE11272-L\$71.95
14" Mirror Kit w/9" BracketsJOE11272-XL\$83.95
17" Mirror Kit w/Std BracketsJOE11282\$73.95
17" Mirror Kit w/5" BracketsJOE11282-L\$79.95
17" Mirror Kit w/9" BracketsJOE11282-XL\$97.95

Wide Angle Mirror Kit With 1-3/4" Clamp

14" Mirror Kit w/Std BracketsJOE11274\$62.95
14" Mirror Kit w/5" BracketsJOE11274-L\$71.95
14" Mirror Kit w/9" BracketsJOE11274-XL\$83.95
17" Mirror Kit w/Std BracketsJOE11284\$73.95
17" Mirror Kit w/5" BracketsJOE11284-L\$79.95
17" Mirror Kit w/9" BracketsJOE11284-XL\$97.95

Wide Angle Mirror Kit With 2" Clamp

14" Mirror Kit w/Std BracketsJOE11276\$73.95
17" Mirror Kit w/5" BracketsJOE11286\$73.95

Wide Angle Mirror Only

14" Mirror OnlyJOE11276\$73.95
17" Mirror OnlyJOE11286\$73.95

Brackets Only With 1-1/2" Clamp

Standard Bracket Only, PairJOE11252\$41.95
5" Long Mirror Bkt Only, PairJOE11262\$51.95
XL 9" Brackets Only, PairJOE11292\$62.95

Brackets Only With 1-3/4" Clamp

Standard Bracket Only, PairJOE11254\$41.95
5" Long Mirror Bkt Only, PairJOE11264\$51.95
XL 9" Brackets Only, PairJOE11294\$62.95

Brackets Only With 2" Clamp

Standard Bracket Only, PairJOE11256\$51.95
5" Long Mirror Bkt Only, PairJOE11266\$62.95



Wide Angle Mirror Kits

Range Bolt-On Bkts.

14" Mirror Kit w/ 1/2" - 2-1/2"

1-3/4" barLON22534\$53.90
1-1/2" barLON22535\$53.90

14" Mirror Kit w/ 1/2" - 5-1/2"

1-3/4" barLON22536\$53.90
1-1/2" barLON22537\$53.90

17" Mirror Kit w/ 1/2" - 2-1/2"

1-3/4" barLON22530\$59.16
1-1/2" barLON22531\$59.16

17" Mirror Kit w/ 1/2" - 5-1/2"

1-3/4" barLON22532\$59.16
1-1/2" barLON22533\$59.16

Mirror Only

14" MirrorLON22544\$26.98
17" MirrorLON22547\$34.18

Brackets Only

No welding - bolts to your roll bars. Brackets CNC machined from billet aluminum.

1/2" to 2-1/2" for 1-3/4" barLON22538\$38.65
1/2" to 2-1/2" for 1-1/2" barLON22539\$38.65
2" to 5-1/2" for 1-3/4" barLON22540\$40.53
2" to 5-1/2" for 1-1/2" barLON22541\$38.73

3-3/4" Spot Mirror Bolt On

Mounts on driver's or passenger's side. Adjusts easily. Bolts in place solidly.

For 1-3/4" barLON22548\$45.03
For 1-1/2" barLON22549\$45.03

Helmet Hook

Protect your helmet. Bolts onto your roll bar. Lightweight billet aluminum.

1-1/2" roll barLON22572\$18.23
1-3/4" roll barLON22570\$18.23

Side View Mirror

Keep in your competition in sight with our 3" diameter Side View Mirror. Mounts to your roll cage in seconds and could be your most important piece of equipment.

3" Side Mirror, 1-1/2" ClampJOE11212\$45.95
3" Side Mirror, 1-3/4" ClampJOE11214\$45.95
3" Side Mirror, 2" ClampJOE11216\$52.95



Extended Side View Mirror

3" Extended Side View Mirror With 1-1/2" ClampJOE11222\$52.95
With 1-3/4" ClampJOE11224\$52.95
With 2" ClampJOE11226\$58.95

Extension Bracket Only

With 1-1/2" ClampJOE11232\$20.95
With 1-3/4" ClampJOE11234\$20.95
With 2" ClampJOE11236\$26.95

Shifter Knob

3/8-16 x 1-5/8

We can't guarantee that you'll find the right gear every time but at least you'll be shifting in style with a polished Joe's Lightweight Shift Knob. Made from 6061 billet aluminum. Threaded 3/8"-16.

JOE16022\$45.95
----------	--------------

Helmet Hook

Tired of scratching up the old brain bucket by just tossing it into the race car. Hang that skid lid on a Joe's Helmet Hook. Simply bolt it to a cross tube on the roll cage and you'll be hooked. Made from 6061-T6 aluminum. Available with a 1", 1-1/4", 1-1/2", 1-5/8" and 1-3/4" clamp.

1"JOE10600-G\$17.95
1-1/4"JOE10601-G\$17.95
1-1/2"JOE10602-G\$17.95
1-5/8"JOE10603-G\$17.95
1-3/4"JOE10604-G\$17.95

Aluminum Shifter Knob

3/8"-16 thread - 1-5/8" Dia

Designed with a better heat insulation. Don't burn your hand late in the race! Extra holes are drilled and the ball is mounted with a stainless steel bolt.

No Insert to come out; knob won't come off in your hand during the race. One piece CNC machined billet alum for lw. 1-5/8" dia.

LON22607\$27.93
----------	--------------

Shifter Stick 3" - Offset

CNC machined billet alum. Lightweight yet strong. To replace heavier steel original. Slotted bottom hole for easier install.

LON22613\$65.10
----------	--------------

Billet Rear End Breather - 1-1/2"

No Welding Required.

LON22566\$37.24
----------	--------------

Backing Disk For Spoiler Support

Use to support Lexan fins or use to fasten spoiler to deck lid. Package of 4.

LON23702\$14.43
----------	--------------

Adjustable Fender Support Kit

2 flexible supports made from LW break resistant material. Springs back to shape. Includes 2 adjustable length supports and all hardware for a quick and professional installation.

LON23740\$46.47
----------	--------------

Magnetic Drain Plug 1/2"-20 Oil Pan

Traps particles and keeps them from damaging your equipment. Check often to spot developing problems.

LON33300\$9.60
----------	-------------

Billet Coil Over Wrench

Billet aluminum keeps coilovers undamaged. Replaceable stainless steel pin. Comfortable handle with rounded edges makes adjustments easy.

LON22589\$43.22
----------	--------------

Upper Lube

A high temp cyl. lube for alcohol engines. It extends engine life and protects and lubricates fuel system. Mixes completely - won't separate and leaves no varnish residue. 16 oz. bottle treats 55 gallons of alcohol.

Upper Lube With Cherry Fragrance	ALL78120\$12.99
----------------------------------	----------	--------------

Valve Cover Breathers

Shielded or non-shielded clamp-on breathers may be used on valve covers with breather tubes.

without ShieldALL36202\$9.99
with ShieldALL36203\$11.99

14" Black Air Cleaner Top

14" Air Cleaner Top - Black	ALL26088\$25.99
-----------------------------	----------	--------------

Double End Wrench Set

Get to those hard to reach places with JOES Double end AN Wrenches. Designed to allow you to turn a fitting in 15-degree increments. Bright anodizing helps find the proper size wrench in a hurry. Precision machined from 6061-T6 aluminum. Set #6-16JOE18000\$125.95 Set #3-20JOE18001\$188.95



Aluminum Adjustable Wrenches

Eliminate the guesswork of which wrench is needed to tighten, remove or check steel braided hose fittings. Aluminum wrenches prevent damage to fitting and are available in two sizes: 8" for fittings up to a -10, and 10" for fittings up to -20.

8"ALL11152\$42.99
10"ALL11153\$57.99

Trailing Arm Nut Wrench

It is 3/8" thick, and fits 1-3/32" jam nuts for 3/4" rod ends commonly used on trailing arms. Jaw is rotated 30 degrees, with an 8-3/4" overall length.

ALL11144\$23.99
----------	--------------

Coil-Over Eliminator Wrench

It is 3/8" thick and fits 2" adjusting nuts on Coil-Over Eliminators (ALL64100). Straight jaw, 7" overall length.

ALL11146\$25.99
----------	--------------

Sway Bar Nut Wrench

A wrench for adjusting sway bar nuts that will clear the radiator and frame rail. It is 3/8" thick with 5-1/2" arm, and 7" overall. Wrench jaw is rotated 30 degrees and fits 1-9/32" nuts.

ALL11142\$23.99
----------	--------------

Steel -12 Wrench

12 point wrench has a rubber hand grip and is a must for tightening -12 AN hose ends on a dry sump pump in seconds.

ALL11180\$19.99
----------	--------------

Billet Aluminum Helmet Hooks

That expensive helmet protects your head - do it a favor and protect it by giving it a place to hang. Keeps it out of the way and within reach. Bolts and seals for rear end are not included.

1-1/4" Helmet HookBRP9256\$19.53
1-1/2" Helmet HookBRP9257\$19.53
1-5/8" Helmet HookBRP9258\$19.53
1-3/4" Helmet HookBRP9259\$19.53



Rear Gears

These high performance gear sets are manufactured to exact tolerances of superior heat treated materials. The right gears for oval track, drag racing, road racing, and high performance street.



GM 7.5" & 7.625"

Part #	Ratio	Price
MOTG875342	3.42	\$230.77
MOTG875373	3.73	\$223.26
MOTG875410	4.10	\$221.11
MOTG875456	4.56	\$221.11

GM 8.5" 10 Bolt

Part #	Ratio	Price
MOTG885273	2.73	\$243.47
MOTG885308	3.08	\$218.97
MOTG885342	3.42	\$221.11
MOTG885373	3.73	\$214.67
MOTG885390	3.90	\$192.95
MOTG885410	4.10	\$210.38
MOTG885456	4.56	\$214.67
MOTG885488	4.88	\$214.67
MOTG885513	5.13	\$225.41

GM 8.875" 12 Bolt

Part #	Ratio	Price
MOTG888342	3.42	\$241.10
MOTG888373	3.73	\$199.64
MOTG888411	4.10	\$193.20

FORD 9"

Part #	Ratio	Price
MOTF890300	3.00	\$262.40
MOTF890325	3.25	\$262.40
MOTF890350	3.50	\$203.94
MOTF890370	3.70	\$241.51
MOTF890389	3.89	\$237.74
MOTF890411	4.11	\$237.74
MOTF890430	4.30	\$246.62
MOTF890457	4.57	\$214.67
MOTF890471	4.71	\$267.54
MOTF890486	4.86	\$231.85
MOTF890500	5.00	\$241.51
MOTF890514	5.14	\$225.41
MOTF890529	5.29	\$241.51
MOTF890543	5.43	\$225.41
MOTF890567	5.67	\$225.41
MOTF890583	5.83	\$241.51
MOTF890600	6.00	\$241.51
MOTF890620	6.20	\$241.51
MOTF890633	6.33	\$241.51
MOTF890650	6.50	\$241.51

MotiveGear Performance®

9" AX Production Lightened Ring and Pinion



This set is the most innovative incarnation of the Ford 9" Gear Set to ever be designed and built. The Motive Gear Performance AX Ring & Pinion is on Average 1.8 to 2 pounds lighter than a standard Ford 9". This is due to the cut away on the underside of the ring gear. The big news doesn't end there! The Motive Gear Performance AX Ring & Pinion boasts an exclusive on these new low ratios: 7.33, 7.16, 7.00, 6.83, and 6.66. Note*** You need a Daytona Style Pinion Support for installation of the Motive Gear Performance AX Series Gear Set.

FORD 9" AX SERIES

Part #	Ratio	Price
MOTF890422AX	4.22	\$275.95
MOTF890430AX	4.30	\$275.95
MOTF890471AX	4.71	\$275.95
MOTF890478AX	4.78	\$351.26
MOTF890500AX	5.00	\$351.26
MOTF890514AX	5.14	\$275.95
MOTF890525AX	5.25	\$275.95
MOTF890529AX	5.29	\$351.26
MOTF890537AX	5.37	\$351.26
MOTF890543AX	5.43	\$351.26
MOTF890550AX	5.50	\$351.26
MOTF890557AX	5.57	\$347.88
MOTF890567AX	5.67	\$351.26
MOTF890583AX	5.83	\$351.26
MOTF890600AX	6.00	\$347.88
MOTF890614AX	6.14	\$341.51
MOTF890620AX	6.20	\$347.88
MOTF890633AX	6.33	\$347.88
MOTF890650AX	6.50	\$341.57
MOTF890666AX	6.66	\$344.51
MOTF890683AX	6.83	\$337.45
MOTF890700AX	7.00	\$310.00
MOTF890716AX	7.16	\$313.17
MOTF890733AX	7.33	\$313.17

MotiveGear Performance®

Mini Spools

Mini Spools are recommended for oval track cars only!

Highest quality heat treated steel.

Ford 9" 28 spline.....MOTMS9-28.....	\$25.95
Ford 9" 31 spline.....MOTMS9-31.....	\$25.95

GM 7.5" 26 spline....MOTMS7.5-26....	\$73.95
(uses stock cross pin)	

GM 8.5" 28 spline.....MOTMS10-28.....	\$73.95
GM 8.2" 28 spline.....MOTMS10C-28.....	\$73.95
GM Cross Pin.....AFC60215.....	\$24.99



REAR END

MotiveGear Performance®

Full Spools

Ford 28 Spline - Lightweight.....MOTFS9-28LW....	\$124.95
Ford 31 Spline - Lightweight.....MOTFS9-31LW....	\$124.95
Ford 35 Spline - Steel.....MOTFS9-35**.....	\$142.95
*Use 3.062 Bore Housing **Use 3.250 Bore Housing	

GM 28 Spline - Steel.....MOTFS10-28.....	\$142.95
GM 30 Spline - Steel.....MOTFS10-30.....	\$142.95
GM 30 Spline - Steel.....MOTFS12-30.....	\$142.95

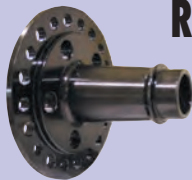

MotiveGear Performance®

Ring and Pinion Installation Kit

All MKT kits include all ring gear bolts, pinion nut, Timken bearings, seals, and gaskets to make installing new gears easy and professional.

MKT Installation Kits

Ford 8.8".....MOTR8.8RMKT.....	\$83.95
GM 12 bolt 8.875".....MOTR12CRMKT.....	\$88.95
GM 10 bolt 7.5 & 7.625.....MOTR7.5GRMKT.....	\$90.95
GM 10 bolt 8.5".....MOTR10RMKT.....	\$92.95

Bearing Kits

Ford 9" Bearing Kit.....MOTR9R.....	\$77.95
Ford 9" Solid Spacer w/shims.....MOT4105.....	\$18.95



9 Inch Ford Ring and Pinions Std and Lightweight

9" Ford Ring and Pinions

Recommended for Circle Track Use.

Ratios Available: 3:50, 3:70, 3:89, 4:11, 4:30, 4:56, 4:71, 4:86, 5:00, 5:14, 5:29, 5:37, 5:43, 5:67, 5:83, 6:00, 6:20, 6:33, 6:50. (8620 Material)

PEMF9(ratio).....\$147.00



Lightened 9" Ford Ring and Pinions

- Saves approximately 3.4 lbs.
- Lighten your rotating weight for faster acceleration!

Ratios Available: 4.11, 4.50, 4.57, 4.63, 4.74, 4.86, 5.00, 5:29, 5:43, 5:67, 5:83, 6:00, 6:20, 6:33, 6:50 and 7:00. 7:00. (8620 Material)

PEMF9(ratio)LW.....\$179.20



9" Ford & GM Mini Spools

9" Ford Mini Spool

28 Spline weighs 2.95 lbs.
PEMMS928.....\$16.73

31 Spline weighs 2.75 lbs.
PEMMS931.....\$16.73

GM 7.5" Mini Spool

26 Spline Mini Spool for 7.5" GM Rear
PEMMS7526...\$61.95

GM 12 Bolt Mini Spool

30 Spline Mini Spool for 12 Bolt GM Rear
PEMMS1230...\$61.95



Ford and GM Full Steel Spools

9" Ford Lite Spool our biggest seller!

28 spline 6.25 lbs.
PEMFS28....\$69.30

31 spline 6.05 lbs.
PEMFS31....\$69.30

9" Ford Drag Spool

28 Spline - 8.55 lbs.
PEMFS28DS...\$89.60

31 Spline - 8.3 lbs.
PEMFS31DS...\$89.60



9" Ford LW Scalloped Spools

31 Spline 5.8 lbs.
PEMFS31LW....\$96.60

28 Spline 6 lbs.
PEMFS28LW....\$96.60

9" Ford 33 Spline Spool

8.3 lbs. Will fit stock case.
PEMFS933LW...\$123.20



PEM racing.com 9" Ford Gear Installation Kits

9" Ford Install Kit

Kit w/crush sleeve; includes pinion nut, o-ring, support shims, housing gasket and ring gear bolts.

PEMF91K...\$24.50



Deluxe 9" Ford Install Kit

Kit w/crush sleeve; includes pinion nut, o-ring, support shims, housing gasket, ring gear bolts, pilot bearing and pinion bearings.

PEMF9DIK...\$48.30



Ford 9" Solid Pinion Spacer Kit w/Shims

PEMF9SPSK...\$10.49



9" Ford Ring and Pinion Kit

Kit with solid spacer and shims; includes pinion nut, o-ring, support shims and housing gasket.

PEMF9RPKSS...\$28.00



9" Daytona Pinion Bearing, Spacer and Seal Kit

Small Daytona Aluminum Pinion Support bearing kit with Timken pinion bearings, pinion seal and solid pinion spacer with shims. (for 28 spline pinion and aluminum pinion support)

PEMF9PSSBRK\$57.00

9" Large Pinion Bearing Spacer and Seal Kit

Large Aluminum Pinion Support bearing kit with Timken pinion bearings, pinion seal and solid pinion spacer with shims. (for 35 spline pinion and aluminum pinion support)

PEMF9PSLBRK\$89.00



9" Ford Yokes (All 28 Spline)

Cast Iron

1-1/16" Cap x 3-7/32" long Short Narrow
PEMYF91310-2\$48.93

1-1/8" Cap x 3-5/8" long Short Wide
PEMYF91330.....\$56.00

Truck - 1-1/8" Cap x 3-5/8" long Long Wide.
PEMYF91330TRUCK...\$69.00



Forged Chrome-Moly Steel 1310 Yoke

This 4140 chrome-moly forging is stronger than either Billet or cast. It will solve problems from a bent yoke or egg-shaped cap holders. This yoke also uses u-bolts instead of the troublesome retainer straps. Black oxide coated and machined for a quality appearance. This yoke uses u-bolts for solid fastening of the u joint to the yoke.

1-1/16" Cap x 3-7/32" long - Short Narrow
PEMYF91310S.....\$61.60

ARP Ring Gear Bolt Kits

Specially hardened, precision-ground washers are included where required. The tremendous shock loads generated at launch by most any drag racing vehicle equipped with today's sticky tire compounds or the acceleration and deceleration of oval track cars put considerable strain on the ring gear. For this reason, the fastener experts at ARP have developed the Pro Series ring gear bolts. They are forged from premium grade 8740 chrome moly steel and are heat-treated to a nominal rating of 200,000 psi tensile strength.

Ford
9" Ford uses 5/8" socket • Thread: 7/16-20 • UHL: 0.940
ARP250-3002.....\$28.52

8.8" & 9" uses 3/4" socket • Thread: 7/16-20 • UHL: 0.750
ARP250-3003.....\$28.52

GM
10 and 12-bolt GM • Thread 3/8-24 • UHL: 0.800
ARP230-3001.....\$30.75

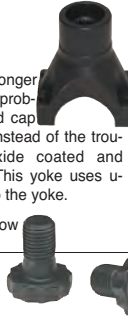

Forged Chrome-Moly Steel 1350 Pinion Yokes

28 Spline - 1-3/16" x 3-5/8" U-Joint dust shield easily removed from 28 spline yoke
PEMYF9135028...\$67.20

35 Spline - 1-3/16" x 3-5/8" U-Joint
PEMYF9135035...\$72.80

Machined from 4140 Chrome-Moly forging. Gold Oxide Coated.



Replacement Quick Change Rear Parts

Fit Winters, DMI & Tiger Rear Ends

PEMQCC0090.....\$40.60.....Forged yoke, 1310 10 spline
PEMQCC0103.....\$34.93.....Post nut for pinion, RH
PEMQCC0105.....\$3.07.....Back cover gasket, sprint
PEMQCC0118.....\$5.95.....Thin side bell o-ring
PEMQCC0119K.....\$35.00.....Aluminum High Nuts for back cover - 10 pieces

PEMQCFS31.....\$208.60.....QC alum. spool, 2.031" journals
PEMQCFS31L.....\$239.95.....QC alum. spool drilled
PEMQCC0133.....\$5.95.....10 piece carrier shim kit
PEMQCC0131/0132K.....\$29.95.....QC ring & pinion bolt and washer kit (12 pcs. each)

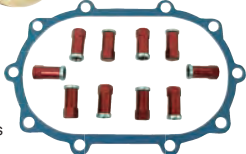

PEM racing.com

9" Ford Bearing Kit

Includes carrier bearings, pinion bearings, pilot bearing and pinion seal.

Bearing: 1.781" ID x 2.891" OD
PEMF9BK1781ID2891OD...\$56.00



9" Ford Ring and Pinion Kit

Ring and pinion kit with crush sleeve includes: pinion nut, o-ring, support shims and housing gasket.
PEMF9RPKCS...\$19.60

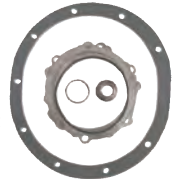

PEM racing.com

Housing Gaskets for 9" Ford, 5 pack

PEMF9HGK...\$9.80



Ring Gear Bolts for 9" Ford, 10 pack

PEMH7162034G8K.....\$9.73



PEM racing.com

Ford 9" Solid Pinion Spacer Kit with Shims for 35 spline pinion

PEMF9SPSK35...\$40.60



9" Ford Pinion Crush Sleeve

PEMF9CSLV....\$2.80



9" Ford Pinion Nut

PEMF9PN...\$3.15



Large Pinion Nut for 35 spline

PEMF9PN35....\$11.13



Quick Change Ring and Pinions

4.11 and 4.86 ratios available. 8620 Alloy Steel. Our ring and pinions were tested in sprint car and late models during the 2012 racing season.

Bare 4.11 QC ring & pinion
4.11.....PEMQC411R&P.....\$152.60
4.86.....PEMQC486R&P.....\$152.60

Lightened Bare 4.11 QC ring & pinion
4.11.....PEMQC411R&PLW.....\$254.80
4.86.....PEMQC486R&PLW.....\$254.80

Loaded 4.11 QC ring & pinion
4.11.....PEMQC411R&PLOADED.....\$306.60
4.86.....PEMQC486R&PLOADED.....\$306.60

LW Loaded QC ring & pinion
4.11.....PEMQC411R&PLWLOADED.....\$376.60
4.86.....PEMQC486R&PLWLOADED.....\$376.60





WELD RACING

Dirt Late Model & Modified Wheels

Rubber Valve Stems 5 Pack
 Heavy Duty stems fit in rims with 1" holes.
 BSC90705...\$5.75

Hoosier Shim Spacer
 WELP601-5050...\$36.08

	Wide 5 XL Wheels	Wide 5 HS Wheels	Size	Bolt Circle	Back Sp	Bead Lock
10"	WEL558-5013.....\$196.80	WEL570-5013.....\$203.36	15 x 10	5 x 10.250	3.00	None
	WEL558-5014.....\$196.80	WEL570-5014.....\$203.36	15 x 10	5 x 10.250	4.00	None
	WEL558-5015.....\$196.80	WEL570-5015.....\$203.36	15 x 10	5 x 10.250	5.00	None
	WEL558-5023.....\$305.86	WEL570-5023.....\$326.36	15 x 10	5 x 10.250	3.00	Outer
	WEL558-5024M.....\$305.86	WEL570-5024M.....\$326.36	15 x 10	5 x 10.250	4.00	Outer
	WEL558-5025M.....\$305.86	WEL570-5025M.....\$316.52	15 x 10	5 x 10.250	5.00	Outer
	WEL558-5053.....\$336.20	WEL570-5053.....\$359.16	15 x 10	5 x 10.250	3.00	Bead-Loc w/Cover
	WEL558-5054M.....\$327.18	WEL570-5054M.....\$359.16	15 x 10	5 x 10.250	4.00	Bead-Loc w/Cover
	WEL558-5055M.....\$336.20	WEL570-5055M.....\$349.32	15 x 10	5 x 10.250	5.00	Bead-Loc w/Cover
	12"	WEL559-5215.....\$202.54	WEL571-5215.....\$202.54	15 x 12	5 x 10.250	5.00
WEL559-5216.....\$202.54		WEL571-5216.....\$202.54	15 x 12	5 x 10.250	6.00	None
WEL559-5223.....\$312.42		WEL571-5223M.....\$333.74	15 x 12	5 x 10.250	3.00	Outer
WEL559-5224.....\$312.42		WEL571-5224M.....\$333.74	15 x 12	5 x 10.250	4.00	Outer
WEL559-5225M.....\$312.42		WEL571-5225M.....\$333.74	15 x 12	5 x 10.250	5.00	Outer
WEL559-5226.....\$312.42		WEL571-5226M.....\$333.74	15 x 12	5 x 10.250	6.00	Outer
WEL559-5253.....\$342.76		WEL571-5253M.....\$365.72	15 x 12	5 x 10.250	3.00	Bead-Loc w/Cover
WEL559-5254M.....\$342.76		WEL571-5254M.....\$365.72	15 x 12	5 x 10.250	4.00	Bead-Loc w/Cover
WEL559-5255M.....\$342.76		WEL571-5255M.....\$365.72	15 x 12	5 x 10.250	5.00	Bead-Loc w/Cover
WEL559-5256M.....\$342.76		WEL571-5256M.....\$365.72	15 x 12	5 x 10.250	6.00	Bead-Loc w/Cover
13"	WEL559-5313.....\$208.28	WEL571-5313.....\$208.28	15 x 13	5 x 10.250	3.00	None
	WEL559-5314.....\$208.28	WEL571-5314.....\$208.28	15 x 13	5 x 10.250	4.00	None
	WEL559-5315.....\$208.28	WEL571-5315.....\$208.28	15 x 13	5 x 10.250	5.00	None
	WEL559-5323M.....\$316.52	WEL571-5323M.....\$338.66	15 x 13	5 x 10.250	3.00	Outer
	WEL559-5324.....\$316.52	WEL571-5324M.....\$338.66	15 x 13	5 x 10.250	4.00	Outer
	WEL559-5325M.....\$316.52	WEL571-5325M.....\$338.66	15 x 13	5 x 10.250	5.00	Outer
	WEL559-5353M.....\$348.50	WEL571-5353M.....\$372.28	15 x 13	5 x 10.250	3.00	Bead-Loc w/Cover
	WEL559-5354M.....\$348.50	WEL571-5354M.....\$359.98	15 x 13	5 x 10.250	4.00	Bead-Loc w/Cover
	WEL559-5355M.....\$348.50	WEL571-5355M.....\$372.28	15 x 13	5 x 10.250	5.00	Bead-Loc w/Cover
	WEL559-5356-6.....\$348.50	WEL571-5356-6.....\$372.28	15 x 13	5 x 10.250	6.00	Bead-Loc w/Cover
14"	WEL559-5413.....\$212.38	WEL571-5413.....\$212.38	15 x 14	5 x 10.250	3.00	None
	WEL559-5414.....\$212.38	WEL571-5414.....\$212.38	15 x 14	5 x 10.250	4.00	None
	WEL559-5415.....\$161.54	WEL571-5415.....\$212.38	15 x 14	5 x 10.250	5.00	None
	WEL559-5416.....\$212.38	WEL571-5416.....\$212.38	15 x 14	5 x 10.250	6.00	None
	WEL559-5423M.....\$322.26	WEL571-5423M.....\$344.40	15 x 14	5 x 10.250	3.00	Outer
	WEL559-5424M.....\$322.26	WEL571-5424M.....\$344.40	15 x 14	5 x 10.250	4.00	Outer
	WEL559-5425M.....\$322.26	WEL571-5425M.....\$334.56	15 x 14	5 x 10.250	5.00	Outer
	WEL559-5426.....\$322.26	WEL571-5426M.....\$344.40	15 x 14	5 x 10.250	6.00	Outer
	WEL559-5427M.....\$322.26	WEL571-5427M.....\$344.40	15 x 14	5 x 10.250	7.00	Outer
	WEL559-5453M.....\$354.24	WEL571-5453M.....\$378.02	15 x 14	5 x 10.250	3.00	Bead-Loc w/Cover
WEL559-5454.....\$354.24	WEL571-5454M.....\$378.02	15 x 14	5 x 10.250	4.00	Bead-Loc w/Cover	
WEL559-5455M.....\$354.24	WEL571-5455M.....\$378.02	15 x 14	5 x 10.250	5.00	Bead-Loc w/Cover	
WEL559-5456-6.....\$354.24	WEL571-5456-6.....\$378.02	15 x 14	5 x 10.250	6.00	Bead-Loc w/Cover	

Wide 5 XL 15"x14" Wh.
 • Bolt Circle.....5 x 10.250
 • Back Space.....5.00
 Bead Lock: None w/Cover
 WEL559-5405-6.....\$280.44
 Bead Lock: Inner Bead-Loc
 WEL559-5435.....\$419.84

1 Piece Ultimate Bead Loc Cover
 WELP650B-5278...\$284.54

Standard 16 Hole Bead Loc Ring
 Silver...WELP650-5275.....\$78.72
 Black...WELP650-5275M.....\$86.10

16 Hole Bead Loc Ring w/Dzus Tabs
 Silver...WELP650-5314-6.....\$90.20
 Black...WELP650-5314M.....\$102.50

16 Hole Bead Loc Ring w/Cover Assembly
 Silver...WELP650-5315-6.....\$120.54
 Black...WELP650-5315M.....\$136.94

16 Hole Bead Loc Alum Cover Only
 Silver
 WELP650-4514A-6
 \$58.22
 Black
 WELP650B-4514A-6
 \$61.50

1/4" Double Drilled Billet Beadlock Solid Mud Lock Ring
 (fits BRP, REDS Gilliam, Weld)
 Includes Sliding Back Cover to Cover Open Holes, Black Anodized
 BRP9433.....\$130.13

WELD RACING Bead Loc Bolt Kit
 16 Pieces
 WELP650-3005...\$12.30

Beadlock Zerks
 16 Pieces
 WELP650-3013...\$17.22

Wide 5 Wheel Spacers
 2" alum spacer uses a triangulated design to minimize rotating weight.
 WIL270-2189C.....\$100.98

Dirt Tire Soap
 Clean your tires like the Pro's! Simply mix with water and spray on your tires before washing them and the mud almost falls off. One gallon container.
 ALL78236.....\$16.99

Wide 5 Wheel Spacers
 1/2" alum spacer slides over studs in hub.
 1/2".....BRP152.....\$78.65
 1" and 1-1/2" alum. spacer includes studs and is made from billet for added strength.

Fits 10 Hole Wheels
 1".....BRP153.....\$159.88
 1-1/2".....BRP154.....\$159.88
 2".....BRP155.....\$159.88

Fits 15 Hole Wheel
 1".....BRP156.....\$154.29
 (fits XL Style Wheels)

5 Bolt - 3/8" Alum Rotor Spacer
 A BRP9481 3/8" thick spacer is required to maintain current caliper spacing if converting from 8 on 7 floating setup.
 BRP9481.....\$27.84

Expansion Ring
 The durable steel mounting ring is powder coated white for a professional appearance and easy visibility in the event that it becomes separated from the wheel.
 DIR20020.....\$29.99

Set of Plastic Plugs for BRP32-2 Mud Covers
 Fits BRP32-2 and BRP32-2BK, Includes 1 - Large center hole plug and 5 Socket hole plugs
 BRP9436.....\$5.53



Late Model 15" x 14" Wide 5 XL 5 Offset

No Bead Loc w/Dzus Tabs No Cover..WEL559-5405NC ..	\$247.00
No Loc w/Cover	WEL559-5405-6 .. \$280.44
No Bead Loc	WEL559-5415 .. \$161.54
Outer Bead Loc	WEL559-5425 .. \$322.26
Inner Bead Loc	WEL559-5435 .. \$419.84
Outer Bead Loc w/Cover	WEL559-5455-6 .. \$354.24

15" Magnum Sprint Spline

	Part #	Size	Bolt Circle	Back Sp	Bead-Loc	Price
14"	WEL735-51434-6	15" x 14"	42 Spline Sprint 4.00	Inner Bead-Loc	\$462.00	
	WEL735-51435-6	15" x 14"	42 Spline Sprint 5.00	Inner Bead-Loc	\$462.00	
	LR WEL735-51436-6	15" x 14"	42 Spline Sprint 6.00	Inner Bead-Loc	\$462.00	
	WEL735-51437-6	15" x 14"	42 Spline Sprint 7.00	Inner Bead-Loc	\$462.00	
15"	WEL735-51534-6	15" x 15"	42 Spline Sprint 4.00	Inner Bead-Loc	\$476.00	
	WEL735-51535-6	15" x 15"	42 Spline Sprint 5.00	Inner Bead-Loc	\$476.00	
	LR WEL735-51536-6	15" x 15"	42 Spline Sprint 6.00	Inner Bead-Loc	\$476.00	
	WEL735-51537-6	15" x 15"	42 Spline Sprint 7.00	Inner Bead-Loc	\$476.00	
17"	WEL735-51753-6	15" x 17"	42 Spline Sprint 3.00	Bead-Loc w/Cover	\$573.18	
	WEL735-51754-6	15" x 17"	42 Spline Sprint 4.00	Bead-Loc w/Cover	\$573.18	
	RR WEL735-51755-6	15" x 17"	42 Spline Sprint 5.00	Bead-Loc w/Cover	\$573.18	
	WEL735-51756-6	15" x 17"	42 Spline Sprint 6.00	Bead-Loc w/Cover	\$573.18	
	WEL735-51757-6	15" x 17"	42 Spline Sprint 7.00	Bead-Loc w/Cover	\$573.18	
18"	WEL735-51853-6	15" x 18"	42 Spline Sprint 3.00	Bead-Loc w/Cover	\$583.84	
	WEL735-51854-6	15" x 18"	42 Spline Sprint 4.00	Bead-Loc w/Cover	\$583.84	
	RR WEL735-51855-6	15" x 18"	42 Spline Sprint 5.00	Bead-Loc w/Cover	\$583.84	
	WEL735-51856-6	15" x 18"	42 Spline Sprint 6.00	Bead-Loc w/Cover	\$583.84	
	WEL735-51857-6	15" x 18"	42 Spline Sprint 7.00	Bead-Loc w/Cover	\$583.84	

15" Direct Mount Rim Shells

	Part #	Size	Bolt Circle	Back Sp	Bead-Loc	Price
8"	WEL860-50813	15" x 8"	5 x 9.750	3.00	None	\$205.34
	WEL860-50814	15" x 8"	5 x 9.750	4.00	None	\$215.66
9"	WEL860-50913	15" x 9"	5 x 9.750	3.00	None	\$227.14
	WEL860-50914	15" x 9"	5 x 9.750	4.00	None	\$227.14
10"	WEL860-51013	15" x 10"	5 x 9.750	3.00	None	\$237.80
	WEL860-51014	15" x 10"	5 x 9.750	4.00	None	\$237.80

10" x 6" Direct Mt Hub/Rim Shells Outer Bead Loc

2 Piece Weld Forged Rim Shell
(Direct Mount Front Hub, Sold Separately)

Part #	Bolt Circle	Back Sp	Price
WEL860-10623	4 x 6.750	3.00	\$285.36

10" x 10" Micro Magnum 27-Spline Micro Outer Bead Loc

Part #	Back Sp	Price
WEL734-11023	3.00	\$442.80
WEL734-11024	4.00	\$442.80

ALLSTAR PERFORMANCE 5" for Dirt Modifieds

Soft Mud Plugs

An economical way to prevent mud build-up inside racing wheels. Foam discs, in 3" and 5" thicknesses, install quickly and easily in 15" dia. wheels. Logo is printed on one side.

5" Black	ALL44150 ..	\$12.99	3" Black	ALL44190 ..	\$10.59
5" Red	ALL44151 ..	\$12.99	3" Red	ALL44191 ..	\$10.59
5" Blue	ALL44152 ..	\$12.99	3" Blue	ALL44192 ..	\$10.59
5" Orange	ALL44153 ..	\$12.99	3" Orange	ALL44193 ..	\$10.59
5" Yellow	ALL44154 ..	\$12.99	3" Yellow	ALL44194 ..	\$10.59
5" Purple	ALL44155 ..	\$12.99	3" Purple	ALL44195 ..	\$10.59

Rotor Spacer For Dirt Late Models

Minimize caliper damage from debris and max cooling capabilities. Rotor spacer bolts to a Wide 5 hub moving the rotor/caliper inboard and out of the wheel shell. When used on the left rear corner, spacer also helps reduce caliper damage from this common debris area. Made from 6061 alum & includes eight mounting bolts.

1.75" Rotor Spacer.....	ALL42014 ..	\$249.99
2.25" Rotor Spacer.....	ALL42016 ..	\$259.99



Dryair System

This new system uses a high quality filtration system consisting of a special Aqua Check filter and a series of specified desiccant beads to essentially double dry your compressed air.

Dryair System	BRP9527 ..	\$388.94
Replacement Filter.....	BRP9527J ..	\$34.95
Replacement Air Media Beads	BRP9527K ..	\$69.99



Tire Deflator

Ensure that all the wet air is removed from your racing tires with this Deflator. Once the tires are deflated, you can then re fill your tires with dry air from your new Dryair System. BRP9243.....



Humidity Gauge

After filling your tires with dry air from your new Dryair System, clip the Humidity Gauge on to the valve stem and make sure your air is as dry as possible. BRP9328.....



WEL735-51415

Reinforcing Plate w/ 1/4-20 Zerk

1.75" L x 1.25" W.....	PAN8201-1/4-20 ..	\$1.59
1.75" L x 1.25" W.....	PAN8201-5/16-18 ..	\$1.59
1.75" L x 1.25" W.....	PAN8202-1/4-20 ..	\$1.59
1.75" L x 0.920" W.....	PAN8203-1/4.....	\$1.59
1.75" L x 0.920" W.....	PAN8203-5/16.....	\$1.59



Alum Washer for 1/4" Body Bolt

1" Washer for 1/4" Body Bolt - Qty 50	PAN8600	\$52.64
1" Washer for 1/4" Body Bolt - Qty 50 - BK.....	PAN8601	\$59.86
1/4-20" Body Bolt w/Washer - Qty 50	PAN8604	\$8.94
1/4-20" Body Bolt w/Washer - Qty 50 - BK.....	PAN8604-BK.....	\$8.56
1/4-20" x 1-1/4" Flanged Body Bolt w/Captured Washer - Qty 50	PAN8605	\$12.98

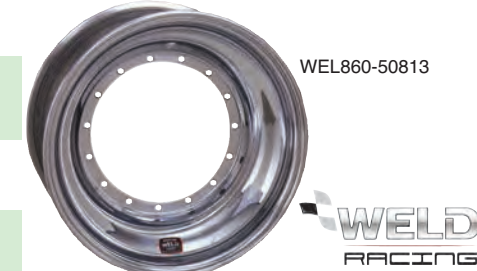

WEL860-50813



Dirt Defender Wheel Covers

This cover was constructed to allow our wheel covers to fit in a universal application. Our design allows you to interchange our cover between a beadlock or non-beadlock wheel. No more digging through a pile of covers to find the right one. Simply keep an extra Dirt Defender cover as a spare and use it on either wheel if needed. Our covers will fit most all wheels including Aero, Bart, Bassett, MRW, Keiser, Weld, and Real wheels to name a few. Made in the USA.



Standard Wheel Cover	
Black.....	DIR10010 .. \$29.99
Dark Blue	DIR10020 .. \$29.99
Green	DIR10030 .. \$29.99
Light Blue	DIR10040 .. \$29.99
Neon Green.....	DIR10050 .. \$32.99
Neon Orange.....	DIR10060 .. \$32.99
Neon Pink.....	DIR10070 .. \$32.99
Neon Yellow	DIR10080 .. \$32.99
Neon Red	DIR10081 .. \$32.99
Orange	DIR10090 .. \$29.99
Pink	DIR10100 .. \$29.99
Purple	DIR10110 .. \$29.99
Red.....	DIR10120 .. \$29.99
White	DIR10130 .. \$29.99
Yellow	DIR10140 .. \$29.99
Grey.....	DIR10150 .. \$29.99

Vented Wheel Cover	
Black.....	DIR10160 .. \$32.99
Dark Blue	DIR10170 .. \$32.99
Light Blue	DIR10180 .. \$32.99
Red	DIR10190 .. \$32.99
Purple	DIR10200 .. \$32.99
Yellow	DIR10210 .. \$32.99
Green.....	DIR10220 .. \$32.99
Orange.....	DIR10230 .. \$32.99
White.....	DIR10240 .. \$32.99
Neon Pink.....	DIR10250 .. \$34.99
Neon Green.....	DIR10260 .. \$34.99
Neon Yellow	DIR10270 .. \$34.99
Neon Orange.....	DIR10280 .. \$34.99
Expansion Ring	DIR20020 .. \$29.99

Front Spindles

A.) 10° LH

for CTD Hub

BER510-CTD...\$398.40



Steel Snout Option

BER510-CTD-STEEL...\$395.95

B.) 10° RH

for CTD Hub

BER504-CTD...\$353.13

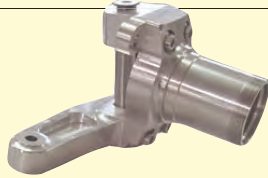

Steel Snout Option

BER504-CTD-STEEL...\$353.13

A.) LH Hub Parts

CTD LH Plate & Snout
BER500-03&07-CTD ... \$148.95

10° Combo ArmBER500-23 ... \$114.95
Spindle BossBER500-11 ... \$43.49
Spindle Boss Lower...BER500-14 ... \$33.35



BER500-23

B.) RH Hub Parts

CTD RH Plate & Snout
BER500-04&08-CTD ... \$148.95

10° Combo ArmBER500-17 ... \$83.95
Spindle BossBER500-11 ... \$43.49
Spindle Boss Lower...BER500-14 ... \$33.35



BER500-17

A.) & B.) Hub Parts

Serrated WasherBER500-30 ... \$3.25
Bolt for SpindleBER500-31 ... \$9.87
Washer Spindle Bolt...BER500-32 ... \$0.48
Spindle BushingBER500-33 ... \$5.34
Ford Hollow King Pin...BER529 \$12.57



Front Hub



Front CTD Hub for Bert Spindles (Race Ready Kit)

Silver ..CTDNM-H01-RR\$339.20
Black...CTDNM-H01-RR-BK...\$364.20

CTDNM-H01
\$164.25

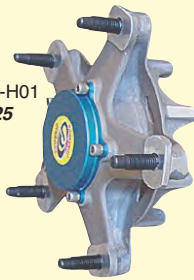

Front CTD Hub for Bert Spindles

Bearing RaceCTD-002\$9.86
Bearing onlyCTD-003\$20.23
REM Finished 2 7/8 CTD Big Bearing and Race
CTD-003-REM\$29.90
Seal onlyCTD-005\$8.25
Hub Seal Low Friction Teflon ..CTD-005ORING ..\$21.00
Lock RingCTD-006\$4.62
Snap RingCTDNM-H04\$1.09
Set ScrewCTD-008\$4.64
Bearings (2) & Seal (1) Kit ..CTD-020\$55.06
Bearings (2), Seal & Lock kit ..CTD-011\$78.33
Hub LockCTD-021\$20.70
Hub Lock ToolCTD-010\$12.57
NY Modified Dust Cap KitCTDNM-H02.....\$19.12



Front Spindles

2-7/8" Left Front Spindle

WIN3795
\$276.95



2-7/8" Right Front Spindle

WIN3796
\$239.95



CTD & Winters Bearings and Seals are not interchangeable

2-7/8" Lock Tool

WIN3269...\$7.87



Front Hub Kit

2-7/8" Front Wide 5 Hub Kit

It includes, polished permanent mold alum hub, alum 5 bolt dust cap, upgraded bearing, & seal kit with trick style alum lock nut.
2 7/8" Front Hub Kit...WIN3750F.....\$161.15
2 7/8" Front Hub Kit with Black Thermal Dispersant Coating
WIN3750F-8208-H.....\$179.46

Front HubWIN3266F.....\$116.44
Bearing.....WIN8658.....\$20.95
Wheel StudWIN5688.....\$4.31
SealBEA7289VLD.....\$21.07
Low Drag SealBEA7289V.....\$11.95
Snap RingWIN8349.....\$3.51
Washer.....WIN3273.....\$4.34
Spindle Alum Nut..WIN3271.....\$11.20
Spindle Steel Nut..WIN3271S.....\$18.20
Hub Cap.....WIN3289.....\$8.40
Gasket.....WIN3278.....\$2.52
Steel Spacer.....WIN3262F.....\$25.20



2-7/8" Bearing & Race

WintersWIN8658.....\$20.95
BSCBEA8658.....\$21.90
BSC (REM Finish)...BEA8658-REM.....\$28.02

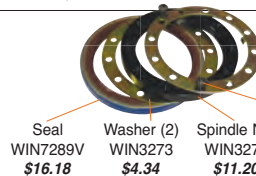

Seal WIN7289V \$16.18
Washer (2) WIN3273 \$4.34
Spindle Nut WIN3271 \$11.20
Screw (3) WIN8740 \$0.39

Front Spindles

10° Front Spindle

Forged 2024-T3 Alum Base. Heat treated and ground spindle pin.
Std.....WIN12291\$199.95
w/ Titanium Shaft ..WIN12291T\$255.15



Steering Arms

Combo Steering Arms....WIN12380..\$71.54
Right Side Steering Arm..WIN12381..\$47.24

WIN12380



WIN12381

Hubs with Races & Studs
LWWIN12290.....\$220.50

Front Hub Kit

Wide 5 Front Hub Kits

5 Sproke Wide 5 Hub. Forged 2024-T3 Alum Construction. Oil or grease friendly. Solid or gundrilled studs are available in steel or titanium. Accepts std or super free angular contact bearings. Kit includes hub, bearing, seals, screw-in dust cap & wheel studs.
Std PairWIN12292.....\$403.95
LW PairWIN12292L.....\$471.95
LW Each.....WIN12292L-1..\$277.12



WIN12292

WIN12292L

Kit Includes

1 Direct Mount Hub (2) WIN12076 *Scall*
1* Direct Mount Hub, LW (2) WIN12076LW *Scall*
2 Single Lip Seal, Viton (2) WIN12363 ...\$13.89
3 Inner Bearing Cone (2) WIN7502\$11.38
4 Inner Bearing Cup (2) WIN7501\$33.25
5 Outer Bearing Cup (2) WIN8635\$8.19
6 Outer Bearing Cone (2) WIN8666\$10.85
7 5/8-11 x 2-1/2" Stud (10) WIN1701\$5.78
8 O'Ring (2) WIN7424\$2.32
9 Screw-In Dust Cap (2) WIN12101 ...\$18.41
10 Plug (2) WIN7874S...\$2.25
*Order Kit WIN12292L for Lightweight Hubs.



Brake Bracket

3/8" offset. Dynalite single caliper. For use with 10-3/4" rotor
WIN12408.....\$41.93



Steel Rotors

10-3/4" dia. 3 on 5 bolt pattern. 0.375" thick. 1/2-13 x 1" hex flat head cap screw WIN8394.
WINS2710\$73.44



Angular Contact

Bearing Upgrade w/ Steel Balls

One Pair of Bearings.....WIN8254S-2.....\$114.24



Individual Bearing Part Numbers

Outer Angular Contact BearingWIN8666-ACS ..\$32.82
Inner Angular Contact BearingWIN8999-ACS ..\$40.18

52" Dirt Modified Front Axles

Bicknell...BRPEC52BOC..\$275.24
TEO.....TEOT007\$295.10



Front Spindles



Bicknell Large Bearing Front Spindle

BRP4588.....\$361.65

Locking Assembly
BRP6230..\$29.01

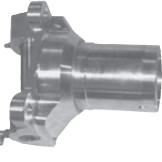

Front Hub Kit

Front Large Bearing Billet Hub

Front Hub Assy includes race, studs, & dust cap.
BRP6203 ..\$334.77



- (1) Front Hub Assembly Red (includes races, studs, & dust cap)...BRP6203* ..\$334.77
(1A) Front Large Bearing Hub Only BRP6203A
(1B) Adaptor Plate.....BRP6201B ..\$100.42
(2) Replacement Inner or Outer Race.BRP6222...\$11.25
(3) Inner or Outer Race ..BRP6224...\$28.03
(4)Replacement Wheel Stud.....BRP2060...\$3.95
(5)Inner Seal.....BRP6225...\$9.97
(6)Inner Seal Snap Ring.....BRP6223...\$7.32
(7)Locking Nut Assembly.....BRP6230...\$29.01
(8) BRP Alum Dust Cap has bolts Bk..BRP6203C..\$38.13
*Add BK for black.



Aluminum Front Spindle

Ford 10" Alum Stubby .859" King Pin Dia
BRP9210.....\$334.73



Billet Wide 5 Conversion Hub

BRP821...\$223.61



Aluminum Steering Arm

- A.) Ford ComboBRP209* ..\$78.45
B.) Ford LowerBRP211* ..\$52.30
C.) HD Ford Combo..BRP209S ..\$78.45
D.) HD Ford Lower...BRP211S....\$52.30
*Add BK for Black

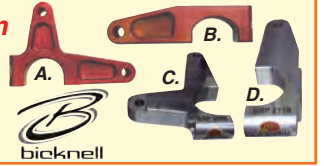

Spindle

BRP 10 Degree Forged Wide Spread Bearing Spindle
BRP9200...\$328.05



Bicknell Billet Hub

Wider bearing stance for greater stability. Less rotor deflection. Comes with BRP4571 dust cap, studs and races.

Red ...BRP4570.....\$219.14
Black...BRP4570BK..\$219.14



1/2" Fine Taper Head Bolts (Pkg. of 3)
Hex Head for easy installation and remove of 3 Bolt Style Rotors on BRP821 and BRP4570 Hubs
BRP9435.....\$27.90

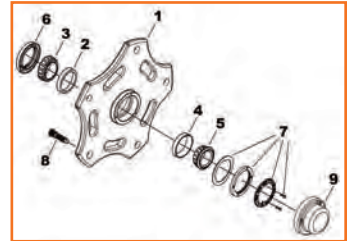

2-7/8" Spindle Nut Washer Assy

A stainless backing washer goes between the nut & bearing and the slotted stainless lock washer for front allows precision adjustments. Nut not included.
BRP9486.....\$14.83



- (1) Front Hub Assembly Red (include races, studs, rotor bolts, & dust cap)BRP4570* ..\$219.14
(2) Replacement Inner RaceBRP826\$call
(3) Inner BearingBRP828\$call
(4) Replacement Outer RaceBRP827\$call
(5) Outer BearingBRP829\$call
(6) Inner Seal.....BRP835\$call
(7) Locking Assembly.....BRP831L...\$16.80
(8) Replacement Stud.....BRP2060...\$3.95
(9) Replacement Dust Cap.....BRP4571...\$29.88
*Add BK for black.

Front Spindles

6 Pin Spindle

10" 6 Pin Short RH w/Single Arm
BER504
\$378.35

Use w/Bert 6 pin and SwayAway Hubs

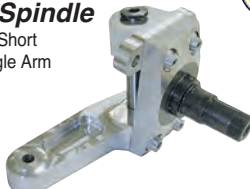

10" 6 Pin Short LH w/Combo Arm
BER510...\$426.86



Hub Assembly Kit
BER530 ..\$242.53



Stand for Rotor
BER532-02 ...\$8.03



King Pins

Ford King Pin

Steel .859...BER529....\$22.36



King Pin w/ Caps

Titanium.....BRP841T ..\$93.39
Red.....BRP841 ..\$36.87

Replacement Caps

Titanium.....BRP841TC.....\$5.61
Red.....BRP841C.....\$5.02

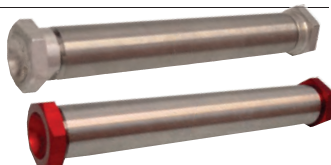

Bearings and Seals



Short 6 Pin

Inner Bearing BEA2796 ...\$16.38
Outer Bearing BEA15120 ..\$10.74
Hub Seals BEA7200 ...\$4.37
Inner Race BEA2735X ..\$9.24
Outer Race BEA15250 ..\$5.10

Steel Hollow King Pin & Cap

Steel Hollow King Pin.....WIN6476....\$18.95
Steel Cap.....WIN1109\$3.95



Ford .859 Washer

AXL.859.....\$1.99



Bushing 10" Spindle

WIN7515\$2.90
BER500-33.....\$5.34



King Pin Shim

.005 Thick..WIN7514..\$0.74



King Pin Shim Kit

WIN7511-01...\$14.95



Steel Spindle Nut

WIN3271S.....\$18.20



6 Pin Spindle Locks

BER535...\$33.76

BRP831L...\$16.80



Replacement Lock Screw
BER535-02...\$1.90

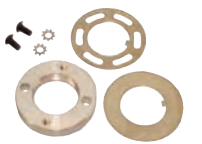

Aluminum Castellated Spindle Nut

WIN3460.....\$9.79





DynaPro Single Billet

It represents the newest generation.

Bore.....Rotor
Size.....Width..Part #.....Price
1.75.....0.38.....WIL120-9689..\$90.60



Forged Billet DYNALITE

Forged DYNALITES are the strongest calipers in the class. The process of stress-flow forging re-aligns the metal's grain structure within the contour of the caliper body.

Bore...Rotor
Size...Width...Part #.....Price
1.75...0.38.....WIL120-6818..\$112.44



wilwood Billet

Powerlite Radial Mount

The Powerlite four piston radial mount caliper combines pure race technology with a new generation of Wilwood performance enhancements. Its sleek profile, superior strength, and durability in higher temp apps are easily adapted to a wide range of sports, rally, and off road driving applications.

Bore.....Rotor
Size.....Width..Part #.....Price
1.25.....0.35.....WIL120-8725..\$128.67
1.38.....0.35.....WIL120-8726..\$128.67

Polymatrix 7912 Pad
Axle Set Pin.....Pad Type
WIL15B-8949K.....B...\$119.35



Caliper Bracket DynaPro

3.75 puts caliper on top. For 12.00 Rotors.

Bicknell Racing Products (Red).....BRP19.....\$19.67
Teo Fabrication (Black).....TEOPR018.....\$20.80
Bert includes hardware (Gold).....CTD-551-K.....\$37.17

Caliper Brackets

Caliper Bracket DYNALITE to Front Spindle 3/16" offset 12. For 12.00 Rotors.

BRP8-1187...\$36.87
Caliper Bracket 3/8" offset
BRP8-1375...\$36.87



Wave Brake Rotor

3/8" x 12.00 (8 Holes).BER544-2...\$93.86
3/8" x 12.00 (3 Holes).BER544.....\$96.92



MSD64316

Dirt MSD 6ALN

7600 RPM Spec Box is now mandate by DIRT 358 Modifieds.....MSD64316.....\$383.95

Wiring Harness

For Spec Box MSD64316
MSDASY25452.....\$35.95
MSDASY25452



Brake Rotor

Brake Rotor 12.00
8 on 7 Wave Style
BRP67.....\$123.02



Std Hole Mt Steel Rotors Drilled

Diameter..Width...Bolt Circle...Hole Type..Lug I.D.
12.00".....0.35".....8 x 7.00".....0.325.....6.38"
Rotor Type..Drilled.....WIL160-0525.....\$94.93



wilwood Billet

Powerlite Radial Mount

The Powerlite four piston radial mount caliper combines pure race technology with a new generation of Wilwood performance enhancements. Its sleek profile, superior strength, and durability in higher temp apps are easily adapted to a wide range of sports, rally, and off road driving applications.

Bore.....Rotor
Size.....Width..Part #.....Price
1.25.....0.35.....WIL120-8725..\$128.67
1.38.....0.35.....WIL120-8726..\$128.67

Polymatrix 7912 Pad
Axle Set Pin.....Pad Type
WIL15B-8949K.....B...\$119.35



wilwood

Northeast DIRT Modified Bracket

WIL250-9655.....\$66.56



Front Caliper Bkt

Front Caliper Bkt CTD to Powerlite Caliper
CTD-552.....\$64.33

Front Caliper Bracket Hardware Kit

Mounts Caliper Bracket to Spindle.
BER553.....\$8.30

1/2" Alum Caliper Mounting Bolts (4 pack) for DIRT Modifieds

BRP9136...\$18.22



Floating Steel Rotors

Diameter...Width...Bolt Circle..Hole Type..Lug I.D.
11.75".....0.35".....8 x 7.00".....SLOT.....6.56"
Rotor Type..Scalloped
WIL160-5855.....\$137.42

Floating Rotor Mounting Hardware

WIL230-5308.....\$44.98

Rotor Bolt Kits

8 pc 5/16-18 x 1" 12 pt bolt kit Bert Hub
BSC80620....\$4.98

Bolt Kits for Fixed Mt Threaded or Through Hole Mt Rotors

Applications Wide 5 Hubs, Threaded Hubs
Qty.....Bolt Size.....Bolt Type
8.00".....5/16-18 x 1.00".....Grade 8 Hex Head
WIL230-0526.....\$5.35

Front Axle Bracket



Red.....BRP1505.....\$41.21
Black...BRP1505BK...\$41.21
Black...BRP1502BK...\$43.04
(7 1/4" Spacing)

Lower Drop Front Axle Bkt

Red.....BRP1501.....\$46.69
Black...BRP1501BK...\$46.68



Teo Standard
TEOPR015A
\$44.85

Teo New Style
Drop Bracket
TEOPR015...\$49.40



Axle Brackets
Blue...CTDNYM-015.....\$34.54
Black..CTDNYM-015-BK..\$34.54



Non Binding Axle Bkt

Allows bottom RF rod to float. Has a needle bearing for smooth operation. Uses acetal washers to prevent any scrubbing during movement. With only 1/8" of travel. Still safe if you make contact. Won't break heim.

BRP9329BK.....\$71.43

2" Lower Non Binding Axle Bracket

(same dimensions as BRP1501). Moves front shock and spring down 2" lower in front. Allows bottom rf rod to float.
BRP9330.....\$89.26

Panhard Bracket

BRP1503
BRP1503BK
BRP1623BK
Red.....BRP1503.....\$36.91
Black...BRP1503BK...\$36.91

Red...BRP1623...\$29.51
Black..BRP1623BK...\$29.51



Panhard Slider

Red...BRP398.....\$30.69
Black...BRP398BK...\$30.69



Black...TEOPR017...\$32.50



Brake Deflectors

Red.....Black
Left.....BRP42L.....BRP42LBK...\$9.33
Right.....BRP42R.....BRP42RBK...\$9.33

Shock Sliders

1 pc. 1-1/2" Mt.Red.....Black
Red Left.....BRP9143L...BRP9143LBK \$36.31
Red Right.....BRP9143R...BRP9143RBK \$36.31
2 pc. 1-1/4" Mt.Red.....Black
Red.....BRP284.....BRP284BK...\$28.84
2 pc. 1-1/4" Mt w/stud
(Dbl. Clamp) Red.....BRP4289.....\$36.87
2 pc. 1-1/2" Mt (Red).....BRP286.....\$28.84



Shock Sliders

Front for 1-1/2".....TEOPR026...\$46.80
Rear for 1-1/4".....TEOPR027...\$48.10



29"x 1 1/8" Solid Torsion Bars

3" Shoulder
 29"x .875.....BER162S.....\$99.95
 29"x .900.....BER163S.....\$99.95
 29"x .925.....BER164S.....\$99.95
 29"x .950.....BER165S.....\$99.95
 29"x .975.....BER166S.....\$99.95
 29"x 1.000.....BER167S.....\$99.95
 29"x 1.025.....BER168S.....\$99.95



29"x 1 1/8" Solid Torsion Bars

29"x .875.....WIN6362-0875...\$89.54
 29"x .900.....WIN6362-0900...\$91.99
 29"x .925.....WIN6362-0925...\$91.99
 29"x .950.....WIN6362-0950...\$91.99
 29"x .975.....WIN6362-0975...\$91.99
 29"x 1.00.....WIN6362-1000...\$104.11
 29"x 1.025.....WIN6362-1025...\$104.11
 29"x 1.050.....WIN6362-1050...\$104.11



29" Solid Torsion Bars

29"x .900.....DMISRC-900-29S...\$103.11
 29"x .925.....DMISRC-925-29S...\$103.11
 29"x .950.....DMISRC-950-29S...\$103.11
 29"x .975.....DMISRC-975-29S...\$103.11



30"x 1-1/8" Gundrilled Sway Bars

4" Shoulder
 30"x 150.....BER180-300...\$116.43
 30"x 250.....BER182-300...\$116.43
 30"x 300.....BER183-300...\$116.43
 30"x 350.....BER184-300...\$116.43



31-1/2"x 1-1/8" Gundrilled Sway Bars

4" & 5 1/2" Shoulder (Total 31 1/2") (for sway bar disconnect)
 31-1/2"x 150.....BER180-31.5...\$116.43
 31-1/2"x 200.....BER181-31.5...\$116.43
 31-1/2"x 250.....BER182-31.5...\$116.43
 31-1/2"x 300.....BER183S...\$119.95
 31-1/2"x 350.....BER184-31.5...\$116.43



Torsion Bar Rate Checker

Check new bars for a base line, check used bars end to end to make sure they aren't permanently twisted. Quick and easy to use, both ends of the bar can be checked in less than 5 minutes!
 BRP9242...\$329.19

Steering Box

Steel 14:1..PRO001...\$742.95

Billet Alum Steering Box

Super LW Billet Alum Steering Box is made from all new materials, not rebuilt core boxes.
 9:1 ratio 30 valve
 PROPR91230BM.....\$1586.25
 1/2 box 9:1 ratio 30 valve
 PROPR91230BM-1/2...\$1586.25
 9:1 ratio 50 valve
 PROPR91250BM.....\$1586.25
 1/2 box 9:1 ratio 50 valve
 PROPR91250BM-1/2...\$1586.25

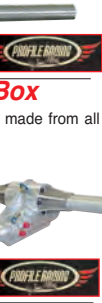

Steering Box Mts

Requires special mounting tabs on chassis (not included). Mach from 6061 Billet Alum. Ultra Light Weight Design. ***Note: Right Side tube may need to be cut to proper length on Profile, GME, and Lee.
 Half Steering box right side mt for KSE Steering Box...BRP9044...\$63.56
 Half Steering box right side mount for a 2" Steering Boxes (Profile, GME, and Lee) BRP9045.....\$63.56



Side Steering Box Mount

TEOPR011...\$74.10

Torsion Bearing & Housing

w/spacer.....BSC40100.....\$35.00
 Bearing only...BEA16522RS.....\$9.00
 Spacer only...BSC40104.....\$3.00



Solid Torsion Bar 29"

29" x 0.875 1-1/8.....SCHRT-B29SD-0875
 29" x 0.900 1-1/8.....SCHRT-B29SD-0900
 29" x 0.912 1-1/8.....SCHRT-B29SD-0912
 29" x 0.925 1-1/8.....SCHRT-B29SD-0925
 29" x 0.937 1-1/8.....SCHRT-B29SD-0937
 29" x 0.950 1-1/8.....SCHRT-B29SD-0950
 29" x 0.962 1-1/8.....SCHRT-B29SD-0962
 29" x 0.975 1-1/8.....SCHRT-B29SD-0975
 29" x 1.000 1-1/8.....SCHRT-B29SD-1000
 29" x 1.025 1-1/8.....SCHRT-B29SD-1025



\$109.50

Gundrilled Torsion Bar 29"

29" x .900.....SCHRT-B29GD-0900
 29" x .925.....SCHRT-B29GD-0925
 29" x .950.....SCHRT-B29GD-0950
 29" x .975.....SCHRT-B29GD-0975
 29" x 1.000.....SCHRT-B29GD-1000



\$135.25

Torsion Stop

A fresh new design that allows easy access to the adjuster bolt for the RR torsion bar of the car. This unique design has the bolt pointing down to the ground away from the fuel cell allowing hassle free weight adjustments.
 BRP9490.....\$89.14



LPS Steel Torsion Stops

2 1/2" straight..LPS4...\$30.95
 2 1/2" curved...LPS6...\$30.95
 2" curved.....LPS11...\$30.95
 1 3/4" curved...LPS14...\$30.95



Aluminum Torsion Bar Stop

Red...BRP263.....\$39.32
 Black..BRP263BK...\$39.32



Torsion Bar Stop

TEOPROSTOP.....\$52.00



Torsion Roller Tool

For easy adjustment or change
 BRP4399...\$55.29



Torsion Bearing

BRP1533...\$9.98



Spherical Torsion Bearing

2.5" OD x .625" Wide
 BRP9297.....\$55.75



Alum. Torsion Bearing Sp

1-1/8" ID, 1/8" Thick..BRP1535...\$4.68



Torsion Bearing

Rubber Seal Boot

It slides over bearings to prevent dirt and dust from entering bearing. Also helps hold the grease in. Fits in between spacer and bearings. 2 required per car or 4 if you have a double bearing torsion rack
 BRP9327.....\$22.25



Torsion Bar Bushings

Oil lite bronze can also be used as a sway bar bushing.



Bar OD...Tube ID...Material.....Part #
 1/8".....1.250".....Brass.....BEA6000...\$4.25
 1 1/8".....1.200".....Blue Hard Plastic...BEA6020...\$5.49
 1 1/8".....1.250".....Nylon.....BRP264...\$8.98
 1/8".....1.310".....Nylon.....BRP265...\$8.98
 1".....1.138".....Nylon.....BRP278...\$8.98

Lead Ballast

It can be used to add weight where it's needed.
 30 lb Lead Ballast.....ALL14179.....\$78.99
 25 lb Lead Ballast.....ALL14180.....\$68.99
 40 lb Lead Ballast.....ALL14182.....\$102.99
 25 lb Lead Clamp On...ALL14181.....\$76.99



Center Steer

Padded Knee Guard

BRP9046...\$95.60



Sprint/Midget Leg Protector

Sprint Leg Protector.....KIR99500.....\$65.95
 Midget Leg Protector.....KIR99502.....\$65.95



Quick Release Sway Bar Arm

16" with cable.....BRP252...\$166.97

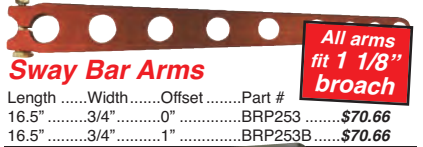

Sway Bar Arms

Length.....Width.....Offset.....Part #
 16.5".....3/4".....0".....BRP253.....\$70.66
 16.5".....3/4".....1".....BRP253B.....\$70.66

All arms fit 1 1/8" broach



Sway Bar Arms

Left.....TEOPR014L.....\$75.40
 Right.....TEOPR014R.....\$75.40

Pitman Arm

9-10 Arm for 9:1 Boxes (Black).....BRP227BK...\$67.61
 11-12-13 Arm (Red) Made 6061.....BRP220...\$67.61
 11-12-13 Arm (Black) Made 6061...BRP220BK...\$67.58
 11-12-13 Arm (Black) Made 2024...BRP221BK...\$82.84

Pitman Arm Pro Machine

14".....TEOPR012C...\$96.85
 9" for 9:1 Boxes.....TEOPR012D...\$96.85

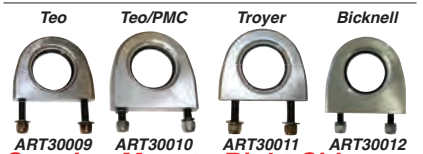

Steering Mounts Right Side

Right side steering mts w/rubberized center. Use for right side only. Made for Teo, Teo/PMC, Troyer, & Bicknell steering boxes.
 Teo.....ART30009.....\$74.00
 Teo/PMC.....ART30010.....\$74.00
 Troyer.....ART30011.....\$74.00
 Bicknell.....ART30012.....\$74.00

Ballast

Weight Mount Bar

Made from 1-1/4" steel tubing. Designed to mt between rear shock mounts above rear end. Will fit in any location a ballast mt is required. Comes w/(4) 1-1/4" ballast mt clamps.
 BRP5112.....\$160.01

Free Moving

Steering Box Mt

3" Bolt Spacing Non Binding Steering Box Mount (TEO Style).....BRP9303.....\$83.68
 2-1/2" Bolt Spacing Non Binding Steering Box Mount (Used on Bicknell Cars).....BRP9298.....\$83.68

Sway Bar Mount

Sway Bar Blocks come complete with bushing and bolts.
 TEOPR013A.....\$28.60

Sway Bar Mount

Mts 1-1/8" bar to frame. Alum. Sold individually..BRP1570...\$18.40

Aluminum Locking Collars

5/8".....BRP181A.....\$6.16
 3/4".....BRP181-1A.....\$6.16
 1 1/8".....BRP1571A.....\$4.87

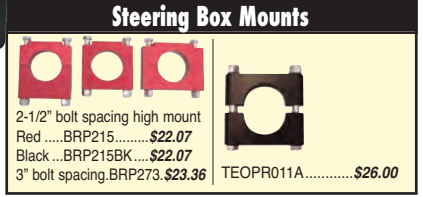



Smarttube Axle System

Tube Length for TEO/BRP Narrow	Part #	Price	Axle Length
20 3/16"	CTD-01720/3/16	\$215.83	25 1/4"
28 1/16"	CTD-01728-1/16	\$234.61	33 1/8"
21 11/16"	CTD-01721-11/16	\$215.83	26 3/4"
22 3/16"	CTD-01722-3/16	\$215.83	28-1/4"
23 15/16"	CTD-017-23-15/16	\$215.83	29-1/8"
24 9/16"	CTD-017-24-9/16	\$215.83	29-5/8"
25 1/16"	CTD-017-25-1/16	\$215.83	30-1/8"
26 1/16"	CTD-017-26-1/16	\$234.61	31-1/8"
27 1/16"	CTD-017-27-1/16	\$234.61	32-1/8"
30 1/16"	CTD-017-30-1/16	\$234.61	35-1/8"



Rear Hub (Race Ready Kit)



Rear Hub

CTD-001.....\$154.30

Bearing Race.....	CTD-002.....	\$9.86
Bearing only.....	CTD-003.....	\$20.23
Bearing only REM CTD-003-REM.....		\$29.90
Seal only.....	CTD-005.....	\$8.25
Low Drag Seal.....	CTD-005ORING.....	\$21.00
Lock Ring.....	CTD-006.....	\$4.62
Snap Ring.....	CTDNYM-H04.....	\$1.09
Set Screw.....	CTD-008.....	\$4.64
Bearings (2) & Seal (1) Kit.....		
	CTD-020.....	\$55.06
Bearings (2), Seal & Lock Kit.....		
	CTD-011.....	\$78.33
Hub Lock.....	CTD-021.....	\$20.70
Hub Lock Tool.....	CTD-010.....	\$12.57



CTD & Winters Bearings aren't interchangeable



2 7/8" Wide 5 Tubes

Tube Length	Part #	Price	Axle Length
20 3/16"	WIN3246-20316	\$134.95	25 1/4"
22 3/16"	WIN3246-22316	\$134.95	28-1/4"
28 1/16"	WIN3246-28116	\$134.95	33 1/8"



2 7/8" Rear Wide 5 Hub

This hub assembly includes, alum drive flange, upgraded bearing and seal kit with trick style aluminum lock nut.

* Hub fits Winters tube only. WIN3750...\$205.95
Rear Big Bearing Wide 5 Hub with Black Thermal Dispersant Coating WIN3750-8208-H...\$223.41

2-7/8" Lock Tool



CTD Low Drag Seal	WIN3273	\$21.00
Washer (2)	WIN3273	\$4.34
Spindle Nut	WIN3271	\$11.20
Screw (3)	WIN8740	\$0.39

Rear TEO/BRP Bkt Kit Adj.

Left Side.....CTD-050-L
Right Side.....CTD-050-R
Left Side - Black...CTD-050-LBK
Right Side - Black...CTD-050-RBK
\$289.83



Rear Teo Kit Torsion Bar

each side
Blue.....CTD-050.....\$249.46
Black.....CTD-050-BK.....\$249.46

Key Ways

0" Offset.....CTD-050-17-0.....\$9.22
1" Offset.....CTD-050-17-1.....\$9.22
2" Offset.....CTD-050-17-2.....\$9.22
3" Offset.....CTD-050-17-3.....\$9.22



2 7/8" Splined Axle Tubes

Tube Length	Part #	Price	Axle Length
20 3/16"	WIN3246-20316-8238	\$218.95	25-1/4"
22 3/16"	WIN3246-22316-8238	\$218.95	28-1/4"
28 1/16"	WIN3246-28116-8238	\$218.95	33-1/8"



8-Bolt Axle Tubes

Tube length for axle length	Part #	Price
15 1/8".....28 1/4".....	WIN6603-07	\$217.95
16 5/8".....29 3/4".....	WIN6603-06	\$217.95
21".....34 1/8".....	WIN6603-04	\$217.95



Clamp On Roller Assembly

Left.....BRP4255.....\$246.02
Right.....BRP4257.....\$246.02

Left Rear Outer Large Bearing Birdcage Plate (with Radius Rod Mount Hole).....BRP4250L.....\$93.39
Left Rear Inner Large Bearing Birdcage Plate (with shock Mount Holes).....BRP4252L.....\$93.39
Right Rear Outer Large Bearing Birdcage Plate (with Radius Rod Mount Hole).....BRP4250L.....\$93.39
Right Rear Inner Large Bearing Birdcage Plate (with shock Mount Holes).....BRP4252R.....\$93.39

Splined Birdcage Assemblies

Right Side...TEOT029-R.....\$337.35
Left Side...TEOT029-L.....\$337.35

Splined Adj Birdcage Wide Roller Std Plate

Left.....TEOT029A-LW.....\$428.35
Right.....TEOT029A-RW.....\$428.35

Birdcage for Smart Tube

TEOTP002L...\$254.15
TEOTP002R...\$254.15

Drive Flange

Drive Flange (Bert) CTD-016.....\$80.38
Drive Flange (Bert) CTD-016-BK.....\$80.38
Drive Flange (BRP) BRP345BK...\$89.78
5-Bolt Drive Flange..WIN3698.....\$59.50
Bolt Kit.....WIL230-6911 \$13.66

Rear Large Bearing Billet Hub

BRP6202BK.....\$334.77

Torsion Bar Roller

It is made with crown to reduce wear to torsion arms. Includes 3 sealed roller bearings for free operation, even when tightened down.
Torsion roller.....BSC40200...\$36.50
Replacement Kit...BSC40201...\$12.00

Pro Torsion Roller Wide - 3"

TEOPROROLLERW...\$53.30

Roller Assembly

BRP9284.....\$49.16

3-1/8" Adjustable Pin

Pull the Pin. This quick pin allows fast adjustment for non adj outboard panhard mts.
BRP9458.....\$13.35

Quad Lock Tubes

Desc	Tube Len	Axle Len	Price
LR Std.....	20-3/16"	25-5/8"	BRP4000-05 \$310.51
LR 2" Long.....	22-3/16"	27-3/4"	BRP4000-10 \$310.51
RR Std.....	28-1/16"	33-3/8"	BRP4000-60 \$310.51

Quad Lock Caliper Bkts

For BRP 2800/Supelite Caliper		
12.18" Rotor - Red.....	BRP9034.....	\$71.43
12.18" Rotor - Black.....	BRP9034BK.....	\$71.43
12" Rotor - Red.....	BRP9038.....	\$71.43
12" Rotor - Black.....	BRP9038BK.....	\$71.43
11-3/4" Rotor - Red.....	BRP9035.....	\$71.43
11-3/4" Rotor - Black.....	BRP9035BK.....	\$71.43

Radial Mt Quad Lock Brake Bkt

BRP9379.....\$89.23

Radial Mount Brackets

For Bicknell Calipers, 11-3/4", 12", 12.190" Rotor Quadlock.....BRP9487.....\$89.23
For Wilwood Calipers, 11-3/4", 12", 12.190" Rotor Quadlock.....BRP9412.....\$89.23

Birdcage Assemblies

Complete birdcage assembly for roller torsion cars. For .810 rotors w/Supelite caliper. Includes shock mount & torsion roller.
Left.....BRP4292.....\$246.02
Right.....BRP4293.....\$246.02

Birdcage Cups

offset 1 3/4" 4 bolt to blank.....BRP4312BP \$55.16
offset 1 3/8" 4 hole to 8 hole.....BRP4312.....\$61.48
offset 1 3/8" 4 hole to multi hole.....BRP4312-1...\$61.48

Birdcages

Right.....TEOTP001-R.....\$244.40
Left.....TEOTP001-L.....\$244.40

QuadLock Birdcage

Complete QuadLock Birdcage Kit
Red.....BRP9032.....\$228.10
Black.....BRP9032BK.....\$228.10

Replacement Parts

Part	Red	Black
2-1/4" Birdcage Spacer (2).....	BRP698.....\$5.01	BRP698BK.....\$5.01
1/4" Steel Radius Rod Spacer (1).....	BRP724.....\$2.34	
Inner Quadlock Birdcage Plate (1).....	BRP9030L/R.....\$106.01	BRP9030L/RBK.....\$106.01
Outer Quadlock Birdcage Plate (1).....	BRP9031L/R.....\$106.01	BRP9031L/RBK.....\$106.01
Shock Mount (1).....	BRP4278L/R.....\$29.23	BRP4278L/RBK.....\$29.23
Slotted washer for roller bolt (1).....	BRP4250W.....\$4.93	
1/2" x 4-3/4" Bolt (bolts birdcage plates together) (2).....	BRPBOL084751C.....	
1/2" x 5" Bolt (roller) (1).....	BRPBOL085001C.....	
1/2" Nylon Nuts (used on 4-3/4" long bolts) (2).....	BRPBOL082C.....	
5/8" Nylon Nuts (used on 3" long radius rod bolt) (1).....	BRPBOL103001C.....	
5/8" Nylon Nut (used on 3" long radius rod bolt) (1).....	BRPBOL102C.....	
1/2" Narrow Nylock Nut (used on 5" long roller bolt) (1).....	BRPBOL083C.....	

Double Shear Rear Mts for Adjustable Birdcage

No more broken shock studs. Designed for extreme track. Conditions by mounting the shock in "double shear". Direct bolt on to your BRP9310 Birdcages. All hardware and spacers included.
Left.....BRP9399L.....\$55.75
Right.....BRP9399R.....\$55.75

Complete Axle Birdcage Zero Degree Quad Lock - Non Adjustable

A lighter and simpler option for those wanting to time the birdcages square to the rear cover. If an adjustable cage isn't required or desired these cages will do exactly the same job.
LR.....BRP9465.....\$228.46
RR.....BRP9466.....\$228.46

Adjustable Timing Quadlocks

Now you can adjust your quadlocks 5" +/- with this pill system. Back to the trusty holes, no more slots. Zero pills are same as stock Quadlock settings. Fits right or left.
BRP9310.....\$316.56

Lower Shock Mount

Notched...BRP4278L...\$29.23
No notch...BRP4278...\$29.23

Day Lube NanoCeramic Racing Grease

DAYLube is a NLGI No. 2 high performance lubricating grease. NanoCeramic particles act as submicroscopic ball bearings that have an a nity or chemical attraction to steel, due to their crystalline molecular structure. These particles formulated over a calcium sulfonate-thickened mixture, create a super low coefficient of friction lubricant with unsurpassed resilience and superior staying power. The formulation of this product provides exceptional resistance to extreme pressures and corrosion, operating over a broad temperature range (-40°F to +800°F).

Nanoceramic Grease 1 oz. Syringe & 2 oz. Jar.....BEA00001.....\$25.99
16 oz. Jar Nanoceramic GreaseBEA00002.....\$49.96
16 oz. Tube Nanoceramic GreaseBEA00003.....\$49.96

Wide 5 Drive Flange Stud Kit

JOE25319.....\$23.95

Bearing Packer for Bert Style or Wide 5

Inject the Proper Amount of Grease with Precision into your Hub Bearings. Pack entire set of 8 Hub Bearings in under 10 minutes. No mess or wasted grease. Hub rolls more freely. Bearings run cooler. Made in the USA.

2-7/8" Bearing.....DRP80532.....\$199.00
Wide 5 (W5) Bearing.....DRP80520.....\$204.00
Bearing Packer Needle.....DRP80541.....\$12.95

Bearings and Seals

Wide 5

Inner Bearing BEA7324.....\$9.84
Outer Bearing BEA7325.....\$9.84
Hub Seal BEA7210.....\$5.45
Hub Locknut Kit BRP320.....\$11.01

Bearing & Seal Kit BEA7210-KIT.....\$23.95

Includes: Hub Seal: BEA7210, Inner Bearing: BEA7324, & Outer Bearing: BEA7325)

O'Ring Seal Wide 5 Hub Low Drag

BEA7210ORING.....\$16.65

8-Bolt Rear Spindles

Rear spindles fit all std 8-bolt alum or steel side tubes on quick change rears. Reduces repair cost by allowing replacement of bent spindle only.
Spindle Standard.....BSC6620.....\$81.95
Spindle Heat Treated.....BSC6620HT.....\$97.95

Spindle Bolt Kit (8pcs.)

5/16-18x1 1/2" for alum. tube...BSC80600.....\$3.26

Starlite "55" Hub w/Five Bolt Drive Front

Std Studs.....WIL270-6735C.....\$128.05
Drilled Studs.....WIL270-6735D.....\$134.30
Black Coarse Studs.....WIL270-6735BC.....\$140.20
Black Drilled Studs.....WIL270-6735BD.....\$147.42

Rear

Std Studs.....WIL270-6513C.....\$115.55
Black Coarse Studs.....WIL270-6513BC.....\$128.67
Black Drilled Studs.....WIL270-6513BD.....\$134.92

Magnesium Wide 5 Hub

Magnesium wide 5 hub 8 on 7" rotor bolt pattern 5/8" drilled coarse studs
BRP6200.....\$104.89

Wide 5 Hub Parts & Accessories

Starlite "55" Drive Flange and Hub Caps

Std 5 Bolt Drive Flange w/Bolts, Washers

WIL270-6732.....\$64.37

Drive Flange Bolts w/Washers - 5 Pack

WIL230-6911.....\$13.66

Starlite Drive Flange and Hub Caps

Drive Flange/Hub Cap Bolt Kit - 8 Pack

WIL230-1378.....\$20.65

Drive Flange Wide 5 Hubs

LW 5 Bolt Drive Flange w/bolts and washers

Black.....BRP348BK.....\$74.71

Red.....BRP348.....\$67.03

Aluminum Drive Flange

7075-T6 Alum 8 bolt drive flange.

WIN3215.....\$37.95

Big Bearing

Spacer Assembly

Spacers can be adjusted to eliminate Free Play & then Hub Nut just needs to be tightened. Makes Hubs turn free. Kit comes w/7 spacers to be able to get proper preload.

Front.....BRP9392.....\$51.90

Rear.....BRP9393.....\$53.42

Adjustable Bearing Spacers and Seal Drivers

Rear Adjustable Bearing Spacer 2-7/8".....DRP007-10510.....\$49.50

Front Adjustable Bearing Spacer 2-7/8".....DRP007-10512.....\$49.50

Front Adjustable Bearing Spacer fits Wide 5.....DRP007-10503.....\$50.78

Front Adjustable Bearing Spacer fits WIN12292.....DRP007-10540.....\$44.16

Front Adjustable Bearing Spacer fits BRP4570.....DRP007-10541.....\$58.52

Seal Driver Front 2-7/8" Winters Bearing.....DRP007-80508.....\$54.10

Seal Driver Rear 2-7/8" Bert Bearing.....DRP007-80509.....\$59.58



Brake Pedal Assembly

TEOT016.....\$85.80

Gas Pedal Assembly

TEOT015.....\$128.70

Side Engine Mounts

Designed for SBC and BBC Engines. Will fit existing 2000 to present Bicknell Chassis. Both ends are encased in polyurethane to prevent cracking. Dampens engine vibration making car run smoother. Mount is adj making bind free mounting.

Left Side.....BRP298L.....\$145.22

Right Side.....BRP298R.....\$145.22

Side Engine Mts

SBC & BBC

Left Mount.....BRP304.....\$46.69

Right Mount.....BRP305.....\$46.69

Rubber Engine Mount for

Crate 525 Engine

Left Side.....BRP9154.....\$145.22

Right Side.....BRP9155.....\$145.22

BBC Right Front Engine Mt

w/ Clearance for Dry Sump Line

Aluminum.....BRP327.....\$40.55

SBC Right Front Engine Mt

Aluminum.....BRP325.....\$40.55

Rubber Engine Mts

Right.....TEOT005AR.....\$80.60

Left.....TEOT005AL.....\$80.60

Side Engine Mount L/S

MT N/C Steel

Right.....TEOT005RS.....\$48.75

Left.....TEOT005LS.....\$48.75

Front Engine Mt SBC MT/R/S

TEOT004S.....\$53.95

Front Engine Mt BBC MT/R/S

TEOT004B.....\$53.95

Coil Over Adapter for Teo Bkt

CTDNYM-024.....\$50.89

Caliper Brackets

Bicknell (red).....BRP1-2.....\$19.67

Bert (gold).....CTD-050-04.....\$13.95

Teo (black).....TEOTP001G.....\$20.15

Remote Caliper Bkts

Fit Superlite and NDL calipers

Bicknell (Red)

For 12 3/16" rotor.....BRP45.....\$73.00

For 12" rotor.....BRP46.....\$73.00

For 11 3/4" rotor.....BRP47.....\$73.00

Floating Brake Assembly

CTD-050-F.....\$409.95

Wave Brake Rotor

3/8" x 12.19 (8 Holes) LW

Rear

BER544-3.....\$93.86

Brake Shut-Off Valve

It has 1/8" NPT inlet and outlet and is rated at 2,000 PSI. Size: 1/2" wide, 1-3/4" long and 1-9/16" high.

ALL48010.....\$48.99

Brake

Pedal Assembly

Steel brake pedal for std cage cars.

BRP411.....\$43.00

Steel brake pedal for 3" driver back cars.

BRP411-3.....\$43.00

Floor Mt Gas Pedal

Alumi Floor Mounted Billet Gas Pedal with Roller Bearings.

Bearing main pivot point and toe grip. Knurled for maximum grip. No welding needed.

BRP9374.....\$83.64

Compact Combination

Master Cyl Kits

Kit features a compact 3.37" lightweight alum short body design. The master cyl provides 1.12" of usable push road stroke.

5/8" bore.....WIL260-10371.....\$75.54

3/4" bore.....WIL260-10372.....\$75.54

13/16" bore.....WIL260-10373.....\$75.54

7/8" bore.....WIL260-10374.....\$75.54

1" bore.....WIL260-10375.....\$75.54

1-1/8" bore.....WIL260-10376.....\$75.54

Brake

Proportioning Valves

Decrease up to 57% line pressure, the most of any available valve. Lever style has six detents.

Knob Style.....WIL260-8419.....\$37.75

Lever Style.....WIL260-8420.....\$74.93

Electric Brake Shut Off

Other valves commonly used as shut-off valves are designed as drag race link locks. Line locks are not designed to be kept in the ON position continuously and can overheat and fail if used as a shut-off. Line locks can also trap pressure in the brake system and cause the brakes to drag.

WIL260-9921.....\$139.94

Tru-Bar 60°

Remote Pedal Master Cylinder

It is interchangeable with the previous slider bearing model, with upgrade kits available for older units. It's race proven to deliver championship caliber performance in all racing conditions.

WIL340-14380.....\$229.39

60° Balance Bar Assembly

For use in tight cockpits, usually to the drivers left.

Uses dual masters with remote reservoirs.

WIL340-4630.....\$170.93

Balance Bar Assembly

WIL340-1757.....\$54.93

Brake Balance

More precise adj. Constant bias bumps and chassis movement do not affect the balance bar like traditional balance bar assemblies. It has roller bearing adj for smoother operation. Knob has detent so bias can't change during racing conditions.

BRPBRC310-9070.....\$328.92

Wide 5 Rotor Bolt Kit (8 pack)

WIL230-0526.....\$5.35

Alum Rear End Filler with AN10 Outlet

BRP9152.....\$78.05

Tire Roller

For Checking Tire Stagger, Check Stagger in one spot, Has Rubber Feet on Bottom to Stop it from Sliding.

BRP9241.....\$77.00



Dirt Modified Bellhousing

Less Flywheel and Coupler Alum. BER300-NFC\$419.95
Mag. BER300-NFC-MAG. \$550.65
Authorized Bert Rebuilder



Flywheel #BER370



Modified applications

Flywheel Chevy.....BER370.....	\$62.50
Flywheel Chevy Extra Offset .080"	
BER370-M	\$62.50
Steel Drive FlangeBER007.....	\$82.40
Alum. Drive FlangeBER007-A.....	\$84.48
Bert Flywheel BoltsBSC80625.....	\$12.00
Flywheel Shim.....BER324.....	\$1.27

Note: Ford and Dodge Available. Call.

Crate CRATE Motor Flywheel



With many tracks mandating crate motors, Bert is there to work with those racers. Here Bert presents the first externally balanced flywheel to couple your crate motor to a Bert transmission. With horsepower limited, the efficiency of the Bert transmission is more important than ever!

Crate Motor Flywheel...BER311-NC-EXT...\$151.35
Shims N.S. Chevy.....WIN62321.....\$2.80



2 5/8" Deep Flywheel Bellhousing Assembly



- with reverse starter mount. Accepts popular internal clutch transmissions with short input shafts including the Falcon Transmission. Mounts included for SB and BB camshaft driven pumps. Includes idler gear, starter ring gear and spacer shims. Chevy...WIN62844...\$375.00

Starter

For Shorty flywheel housing WIN62844 and others. WIN62910...\$238.00



Ball Spline Driveshafts

Fits Newer TEO, BRP, and Troyer 23" (TEO)...BER240-23...\$775.56

Driveshafts

Gun drilled & internally polished for LW & added strength.

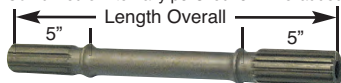

16 x 16 Spline for open drive.
18"BER252.....\$147.62
20"BER253.....\$147.62
22"BER254.....\$151.34

Note : Available from 15" to 30".
16 x 10 Spline Closed Drive also available call.

Hollow Steel Driveshaft

32-32 Spline - 20...DMISRC-2467-32...\$212.70

U-Joint Yoke - Long

Steel Billet U-Joint Yoke - Long 32 Spline
DMISRC-2342-32...\$191.30

Driveshaft Cover

Will fit all 2000 to present mid rail chassis. Direct replacement for BRP1645 for cus. backnell tomers using the new Bert Trans. 11.8 lbs. BRP9020.....\$70.64

Driveshaft Cover

For MOZ Trans (Stock 38" engine setback) BRP1645.....\$68.56

Shifter Slot Cover

Bolt On for Bert Remote Shifter BRP9020-3.....\$17.83

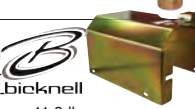

Mastertorque 180-Foot lbs

5 Position Indexing. No Heat Soak Problems. Clears Oil Pans if OE Starter Fits. Billet Alum Adapter Block. 4.4:1 Gear Reduction Ratio. Power for up to 12:1 Compression. Mounting Bolts Included. Dyno Test Results Included. Weight: 10.5 lbs.

Bert/ Brinn TransPOW9614....\$198.50

XS Torque 200-Foot lbs

Highest Torque. Most Efficient. No Heat Soak Problems. Clears All Headers. Clears Oil Pans, OE Location Billet Alum Adapter Block. 4.4:1 Gear Reduction Ratio. Cranking Power For up to 18:1 Compression. Mounting Bolts Included. Dyno Test Results Included. Weight: 8.0 lbs.

Bert/ Brinn TransPOW9514....\$223.44

Clockable Late Model Bert Transmission Adjustable Mount.....POW9529....\$233.42

Inboard Fits Bert & Winters Bellhousing's Starter

Modified Starters. Inboard mount for use on Bert style bellhousings on Modifieds. BER323M2KW...\$229.90

Modified 1.4kw Bert Starter

BSC20021.....\$195.75

Bert Trans Gaskets

Front Cover/Main Case Gasket .015 Thick BSCBER001.....\$3.50
Bert Side Cover Gasket .030 Thick BSCBER002.....\$3.75
Bert Rear Cover Gasket .030 Thick BSCBER003.....\$3.95
Note: All trans rebuild parts available.



Dirt Modified Transmission Original Style

Open Drive TransBERMOZ.....\$1789.53
Closed Drive Trans...BERMCZ.....\$1889.13

Dirt Modified Transmission 2nd Generation

BER1200.....\$1815.00
With No Shifter
Authorized Bert Rebuilder

Remote Side Shifter Kit

For BER1200 Trans...BER078-SG...\$239.95

Bert Clutch Handle Knob

BER078-C...\$15.95

Cable for Remote Shifter

BER078-1C.....\$109.38

2nd Generation Modified Remote Shifter Cable Plate "Trans Side"

BER078-1CP...\$30.27

New Style Clutch Handle

BER066-1C.....\$17.40

Replacement Modified Shifter Kit

The first thing to go when you lose a driveshaft is your shift linkage. Replace the whole thing with this complete kit. Includes rod ends and everything. BER078-M...\$120.68

Bert & Winters Hand Clutch..ENG18875...\$99.50

Falcon Shorty Transmission

It features 2 forward speeds and a reverse with an integral hydraulic applied clutch which operates low and reverse gears. High gear is a 1 to 1 direct drive ratio, while low gear is a 2.4 to 1 ratio.

WIN60150...\$1344.00

Falcon Shifter Shorty Replacement

WIN60115S...\$140.05

Neapco U-Joints

1310 1-1/16 x 3 1/4NEA1-0153.....\$12.52
1310 9/16" hole in center. NEA1-0153X-SP. \$20.67

Spicer U-Joints

1310 1-1/16 x 3-1/4
Greaseable..... SPI5-53X.....\$13.95
Non Greaseable..... SPI5-1310X.....\$18.95

U-Bolts (pair) BSC5855.....\$6.24

Dirt Modified Drive Line

Specify Length When Ordering (Qty: 1)

Groundlind from solid stock, this 32 spline drive shaft has several advantages. Compared to the antiquated 16 spline assembly, which binds under load, this updated 32 spline assembly glides effortlessly. A large (1.275) O.D. results in less drive shaft whip, extended joint life and reduced drive shaft vibration. WIN5991-XX.....\$168.95

Alum 32 Spline Slip Yoke (Qty: 1)

WIN4865-32.....\$140.00

U-Bolt Assembly (Qty: 2)

WIN3655M.....\$25.90

Spring..WIN5269...\$5.74

Strange Oval Slip Yokes 32 Spline 1310

Forged Driveshaft...STRDYM235....\$169.95

Billet Driveshaft for Bert Trans STRDYM205.....\$127.95

Billet U-Joint Strap Kit 1310 for Bert Trans Yoke STRDYM205-1.....\$70.95

Slip Yoke Spring STRDYMSPRING.....\$2.80

Drive Shafts

19" LW Driveshaft Length 20" CTC FAS2-083M-DM-19.....\$297.25

20" LW Tubular Driveshaft Std Length 22.5" CTC FAS2-083M-DM-20.....\$287.95

Billet U-Bolt Kits

FASBBSK...\$48.50

Transmission Yoke

Replacement Yoke Open Drive BER053-HD.....\$108.95

Rear End Yokes

New Style Rear Yoke WIN3533.....\$40.52

Yoke 10 Spline Alum WIN5038AS.....\$122.19

Slip Yoke

5.5" Yoke 16 Spline FAS6133....\$30.95

Billet Aluminum U-Joint Caps (sold in pairs)

Machined from high strength billet alum. Extra clearance for high misalignment driveshafts. Sold in pairs. Includes all necessary mounting hardware. Black anodized for wear & corrosion resistance. Bolts and seals for rear. BRP9246.....\$33.42

Quick Change Gears

• SAE 8620 • 10 spline • All Ratios in Stock!
WIN8500.....\$71.99



10 Spline

Gear Set #	Low Spur		# of Teeth	4.12 R&P (8-33 Tenths)		4.57 R&P (7-32 Tenths)		4.86 R&P (7-34 Tenths)	
	Ratio	Spur		Low	High	Low	High	Low	High
WIN8501	1.000	1.000	21/21	4.12	4.12	4.57	4.57	4.86	4.86
WIN8502	0.964	1.037	27/28	3.97	4.27	4.41	4.74	4.69	5.04
WIN8505	0.960	1.042	24/25	3.96	4.29	4.39	4.76	4.67	5.06
WIN8515A	0.955	1.048	21/22	3.93	4.32	4.36	4.79	4.64	5.09
WIN8515	0.950	1.053	19/20	3.91	4.34	4.34	4.81	4.62	5.11
WIN8526	0.931	1.074	27/29	3.84	4.43	4.26	4.91	4.53	5.22
WIN8506	0.920	1.087	23/25	3.79	4.48	4.20	4.97	4.47	5.28
WIN8525	0.909	1.100	20/22	3.75	4.53	4.16	5.03	4.42	5.34
WIN8512	0.897	1.115	26/29	3.69	4.60	4.10	5.10	4.36	5.42
WIN8507	0.885	1.130	23/26	3.65	4.66	4.04	5.17	4.30	5.49
WIN8507A	0.875	1.143	21/24	3.61	4.71	4.00	5.22	4.25	5.55
WIN8517	0.867	1.154	26/30	3.57	4.75	3.96	5.27	4.21	5.60
WIN8517A	0.857	1.167	24/28	3.53	4.81	3.92	5.33	4.17	5.67
WIN8508A	0.852	1.174	23/27	3.51	4.84	3.89	5.37	4.14	5.70
WIN8508	0.846	1.182	22/26	3.49	4.87	3.87	5.40	4.11	5.74
WIN8519	0.840	1.190	21/25	3.46	4.91	3.84	5.44	4.08	5.78
WIN8509A	0.833	1.200	25/30	3.43	4.94	3.81	5.48	4.05	5.83
WIN8509	0.826	1.211	19/23	3.40	4.99	3.78	5.53	4.02	5.88
WIN8511	0.815	1.227	22/27	3.36	5.06	3.72	5.61	3.96	5.96
WIN8503	0.806	1.240	25/31	3.32	5.11	3.69	5.67	3.92	6.02
WIN8513	0.800	1.250	20/25	3.30	5.15	3.66	5.71	3.89	6.07
WIN8518	0.793	1.261	23/29	3.27	5.20	3.62	5.76	3.85	6.12
WIN8518A	0.786	1.273	22/28	3.24	5.24	3.59	5.82	3.82	6.18
WIN8504A	0.783	1.278	18/23	3.22	5.26	3.58	5.84	3.80	6.21
WIN8520A	0.778	1.286	21/27	3.20	5.30	3.55	5.88	3.78	6.25
WIN8504	0.774	1.292	24/31	3.19	5.32	3.54	5.90	3.76	6.27
WIN8520	0.769	1.300	20/26	3.17	5.36	3.52	5.94	3.74	6.31
WIN8522	0.760	1.316	19/25	3.13	5.42	3.47	6.01	3.69	6.39
WIN8516	0.750	1.333	18/24	3.09	5.49	3.43	6.09	3.65	6.48
WIN8510	0.739	1.353	17/23	3.05	5.57	3.38	6.18	3.59	6.57
WIN8510A	0.733	1.364	22/30	3.02	5.62	3.35	6.23	3.56	6.62
WIN8534A	0.727	1.375	16/22	3.00	5.67	3.32	6.28	3.54	6.68
WIN8534	0.724	1.381	21/29	2.97	5.69	3.31	6.31	3.52	6.71
WIN8514	0.719	1.391	23/32	2.96	5.73	3.29	6.36	3.49	6.76
WIN8514A	0.714	1.400	20/28	2.94	5.77	3.26	6.40	3.47	6.80
WIN8535	0.708	1.412	17/24	2.92	5.82	3.24	6.45	3.44	6.86
WIN8532	0.704	1.421	19/27	2.90	5.86	3.22	6.49	3.42	6.90
WIN8532A	0.697	1.435	23/33	2.87	5.91	3.19	6.55	3.39	6.97
WIN8524	0.690	1.450	20/29	2.84	5.97	3.15	6.63	3.35	7.04
WIN8536	0.680	1.471	17/25	2.80	6.06	3.11	6.72	3.31	7.14
WIN8537	0.677	1.476	21/31	2.79	6.08	3.10	6.75	3.29	7.17
WIN8523	0.667	1.500	22/33	2.75	6.18	3.05	6.86	3.24	7.29
WIN8521	0.655	1.526	19/29	2.70	6.29	2.99	6.98	3.18	7.41
WIN8521A	0.652	1.533	15/23	2.69	6.32	2.98	7.01	3.17	7.45
WIN8527	0.647	1.545	22/34	2.67	6.37	2.96	7.06	3.15	7.51
WIN8543	0.640	1.563	16/25	2.64	6.44	2.93	7.14	3.11	7.59
WIN8528	0.633	1.579	19/30	2.61	6.51	2.89	7.22	3.08	7.67
WIN8528A	0.630	1.588	17/27	2.59	6.54	2.88	7.26	3.06	7.71
WIN8529	0.625	1.600	15/24	2.58	6.59	2.86	7.31	3.04	7.77
WIN8539	0.621	1.611	18/29	2.56	6.64	2.84	7.36	3.02	7.83
WIN8530	0.615	1.625	16/26	2.54	6.70	2.81	7.43	2.99	7.89
WIN8540	0.613	1.632	19/31	2.53	6.72	2.80	7.46	2.98	7.93
WIN8541	0.607	1.647	17/28	2.50	6.81	2.76	7.53	2.95	8.00
WIN8531	0.600	1.667	21/35	2.47	6.87	2.74	7.62	2.92	8.10
WIN8533A	0.593	1.688	16/27	2.44	6.95	2.71	7.71	2.88	8.20
WIN8533	0.588	1.700	20/34	2.42	7.00	2.69	7.77	2.86	8.26
WIN8531A	0.583	1.714	21/36	2.40	7.06	2.67	7.83	2.84	8.31
WIN8530A	0.577	1.733	15/26	2.38	7.14	2.64	7.92	2.80	8.42
WIN8550	0.571	1.750	20/35	2.35	7.21	2.61	8.00	2.78	8.50
WIN8551	0.567	1.765	17/30	2.34	7.27	2.59	8.07	2.75	8.57
WIN8552	0.563	1.778	18/32	2.32	7.32	2.57	8.12	2.73	8.64
WIN8553	0.559	1.789	19/34	2.30	7.37	2.55	8.18	2.72	8.69
WIN8554	0.556	1.800	15/27	2.29	7.42	2.54	8.23	2.70	8.74
WIN8555	0.552	1.813	16/29	2.27	7.47	2.52	8.28	2.68	8.80
WIN8556	0.548	1.824	17/31	2.26	7.51	2.51	8.33	2.67	8.86
WIN8557	0.533	1.875	16/30	2.20	7.73	2.44	8.57	2.59	9.11
WIN8558	0.531	1.882	17/32	2.19	7.76	2.43	8.60	2.58	9.14

Quick Change Gear Case

Sturdy composite storage case protects and holds up to 8 sets of quick change gears. Case has molded in carrying handles and metal hinges. 5" x 8" x 15-1/2" overall when closed.
ALL14355...\$49.99



10-Spline Professional Series Gears

SCS 10-Spline Quick Change Gears, Sets #1 thru #28 are Max Lightened, where possible, without sacrificing the strength! SCS Gears are made of 9310 Aircraft Alloy for max strength. Each gear is Crown Shaved (Ground before Heat Treat) to minimize backlash and run out, broached for proper 10-spline shaft fit and Black Oxide finished.

SCS(Gear Set #).....\$176.99



10-Spline Sportsman Series Gears

The Sportsman Series gears are CNC Crown Hobbled to produce a quality that meets the exacting std accepted by SCS. The gears are not lightened and are made of 8620 material. They are Heat Treated as are the Professional Series, but will have a REM finish rather than the Black Oxide.

SCS10(Gear Set #).....\$79.95

SCS 10 Spline Quick Change Gear Chart

# Professional	# Sportsman	4.11 R&P (9-27 Teeth)		No. of Teeth	4.86 R&P (7-34 Teeth)		4.57 R&P Low - High
		Low	High		Low	High	
SCS01	SCS1001	4.11	4.11	28/28	4.86	4.86	4.57 - 4.57
SCS02	SCS1002	3.96	4.26	27/28	4.68	5.04	4.41 - 4.74
SCS05	SCS1005	3.94	4.28	24/25	4.66	5.07	4.38 - 4.76
SCS15	SCS1015	3.90	4.33	19/20	4.61	5.12	4.34 - 4.81
SCS15K	SCS1015K	3.85	4.38	15/16	4.56	5.18	4.28 - 4.88
SCS26	SCS1026	3.83	4.41	27/29	4.52	5.22	4.25 - 4.91
SCS06	SCS1006	3.78	4.46	23/25	4.47	5.28	4.21 - 4.96
SCS25	SCS1025	3.74	4.52	20/22	4.42	5.35	4.16 - 5.03
SCS12	SCS1012	3.68	4.58	26/29	4.36	5.42	4.10 - 5.09
SCS07	SCS1007	3.63	4.64	23/26	4.30	5.49	4.04 - 5.16
SCS07K	SCS1007K	3.58	4.69	21/24	4.23	5.54	4.00 - 5.22
SCS17	SCS1017	3.55	4.76	19/22	4.19	5.63	3.95 - 5.29
SCS08K	SCS1008K	3.49	4.83	17/20	4.13	5.71	3.89 - 5.37
SCS08	SCS1008	3.48	4.85	22/26	4.11	5.75	3.86 - 5.40
SCS19	SCS1019	3.45	4.89	21/25	4.08	5.78	3.84 - 5.44
SCS09K	SCS1009K	3.42	4.93	25/30	4.05	5.83	3.81 - 5.48
SCS09	SCS1009	3.39	4.97	19/23	4.01	5.88	3.77 - 5.53
SCS11	SCS1011	3.35	5.04	22/27	3.96	5.97	3.72 - 5.61
SCS03	SCS1003	3.31	5.10	25/31	3.92	6.03	3.68 - 5.67
SCS13	SCS1013	3.29	5.14	20/25	3.89	6.08	3.65 - 5.71
SCS18	SCS1018	3.25	5.19	19/24	3.85	6.13	3.62 - 5.77
SCS04K	SCS1004K	3.21	5.26	18/23	3.80	6.21	3.58 - 5.84
SCS04	SCS1004	3.18	5.31	24/31	3.76	6.28	3.54 - 5.90
SCS20	SCS1020	3.16	5.34	20/26	3.74	6.32	3.51 - 5.94
SCS22	SCS1022	3.12	5.41	19/25	3.69	6.39	3.47 - 6.01
SCS16	SCS1016	3.08	5.48	24/32	3.65	6.48	3.43 - 6.09
SCS10	SCS1010	3.04	5.55	20/27	3.60	6.56	3.38 - 6.17
SCS34	SCS1034	3.00	5.63	19/26	3.55	6.65	3.34 - 6.25
SCS14	SCS1014	2.95	5.72	23/32	3.50	6.76	3.29 - 6.35
SCS14K	SCS1014K	2.93	5.76	20/28	3.47	6.81	3.26 - 6.40
SCS35	SCS1035	2.91	5.80	17/24	3.44	6.86	3.24 - 6.49
SCS32K	SCS1032K	2.87	5.89	23/33	3.39	6.97	3.18 - 6.56
SCS24	SCS1024	2.83	5.96	20/29	3.35	7.04	3.15 - 6.63
SCS36	SCS1036	2.80	6.04	17/25	3.30	7.15	3.11 - 6.72
SCS37	SCS1037	2.78	6.07	23/34	3.29	7.18	3.09 - 6.76
SCS23	SCS1023	2.74	6.16	18/27	3.24	7.29	3.05 - 6.85
SCS21	SCS1021	2.69	6.28	17/26	3.18	7.43	2.99 - 6.99
SCS27	SCS1027	2.66	6.35	22/34	3.15	7.51	2.96 - 7.06
SCS43	SCS1043	2.63	6.42	16/25	3.11	7.59	2.93 - 7.14
SCS28	SCS1028	2.60	6.49	19/30	3.08	7.67	2.89 - 7.22
SCS29	SCS1029	2.57	6.58	15/24	3.04	7.77	2.86 - 7.31
SCS30	SCS1030	2.53	6.67	16/28	2.99	7.89	2.81 - 7.43
SCS41	SCS1041	2.49	6.77	17/28	2.95	8.00	2.77 - 7.53
SCS31	SCS1031	2.46	6.85	21/35	2.91	8.10	2.74 - 7.62
SCS33K	SCS1033K	2.43	6.94	16/27	2.88	8.20	2.71 - 7.71
SCS33	SCS1033	2.41	7.00	17/29	2.85	8.28	2.68 - 7.79
SCS31K	SCS1031K	2.39	7.05	14/24	2.83	8.33	2.66 - 7.83
SCS30K	SCS1030K	2.37	7.12	15/26	2.80	8.42	2.64 - 7.92



Premium 9310 Material

Standard 8620 Material

Premium #17.95	Standard \$59.95	No. Teeth	4.11 High - Low		4.86 High - Low	

Adjustable Torque Arm

Comes stock with adj holes of +3, 0, & -3 degrees. Once the torque arms have been adjusted- just install the lock pin & never worry about breaking your torque arms again! Adj torque arm pickup bolt- Easily allows changing from 2nd to 3rd hole! Direct bolt on part for existing chassis 2000-present.....BRP9018...\$441.12

Front Plate Left Side Only.....	BRP9008.....	\$82.02
Front Plate Right Side Only.....	BRP9007.....	\$82.02
Rear Plate Common for Left and Right.....	BRP9006.....	\$52.71
Front Spacer only 2 Required.....	BRP9014.....	\$4.24
Rear Spacer only 2 Required.....	BRP9013.....	\$4.24
Locating Washer 2 Required (1 per side).....	BRP765.....	\$2.34
Cross Shaft for Adj Torque Arms Only.....	BRP9017.....	\$30.34
5/8" Collar 2 Required 1 Per Side.....	BRP181A.....	\$6.16



Torque Arm Plates Sold Each

28" x 32 1/2" Thickness: 3/8", 0".....	BRP426...\$110.71
28" x 32 1/2" Thickness: 3/8", -3".....	BRP432...\$110.71
28" x 32 1/2" Thickness: 3/8", -3" (New torque arm for transmission clearance for 2" motor set back cars.)	BRP9295...\$110.71



Upper Lift Bar Coil Mount

New generation lift arm coil mount. No need to loosen a clamp and slide it around. Pull the pin and choose between 3 position each one being spaced 2" apart. Fits 1-1/2" tube.
BRP9414.....\$94.80



Torque Arm Plates

Sold Pair 28" x 32 1/2" Adj. TEO Torque Arm
TEOT001AB.....\$386.75

Torque Arm Hoops

Front Hoop.....TEOT036.....\$50.70
Rear Hoop.....TEOT037.....\$46.15



Torque Arm Hoops

Front Hoop.....BRP1646.....\$44.86
Rear Hoop.....BRP1647.....\$38.14



Panhard Bar Mts

1 Plate only.....BRP4550.....\$72.36
2 Plates, spacers and bolts.....BRP4551.....\$195.95
Support Bar.....BRP4552.....\$31.39



Adjustable Rear Outer Panhard Mount

Includes shaft, gear drive and knob. Assembled.
Cockpit Adj Rear Outer Panhard Assy Red (Add BK for black) BRP4549.....\$568.54
Non Cockpit Adj Rear Outer Panhard Mt Assy Red

Add BK for Black (BRP4548BK).....	BRP4548.....	\$375.62
Front aluminum plate with laser etched numbers.....	BRP4540.....	\$96.40
Rear aluminum plate.....	BRP4541.....	\$96.40
Upper threaded center spacer block.....	BRP4542.....	\$21.04
Lower Solid center spacer block.....	BRP4543.....	\$15.54
Rod End slider block.....	BRP4544.....	\$58.91
7/8" Threaded adjuster rod.....	BRP4545.....	\$24.89
90 degree Swivel gear drive (BRP4549 only).....	BRP4546.....	\$125.06
Cockpit adjuster shaft knob (BRP 4549 only).....	BRPSTE8.....	\$17.24
Cockpit adjuster shaft (BRP 4549 only).....	BRP4547.....	\$22.42
3/8" detent ball.....	BRP50909.....	\$10.62
Bolt Kit for BRP4548/BRP4549.....	BRP4549B.....	\$12.23
Cockpit Adjustable Left Side Panhard (Silver).....	BRP9588.....	\$400.40
Non-Adjustable Left Side J Bar Mount Panhard (Silver).....	BRP9590.....	\$143.99

Panhard Bar Mounts

Adjustable Panhard Mt TEOT002ANG ..\$603.20	TEOT002N	TEOT003
Panhard Mount TEOT002N.....\$209.30	TEOT002ANG	
Inner Panhard Mount TEOT003.....\$80.60		



Adjustable Panhard Mount

BER410-B.....\$502.82

Panhard Adjuster Seal



Fully exposed gears are prone to jam-ups as a result of dirt. It eliminates the problem by totally enclosing the gears in a flexible, enclosed environment.
SEAPH5003-R.....\$38.95

Rear Panhard Bar (Rubber Bushing Style)

Its design for slick track apps. Fully adj & is direct replacement for existing solid panhard bars. Utilizing rubber bushings to increase sidebite.
Red.....BRP9120.....\$297.64
Black.....BRP9120BK.....\$297.64



Wide Roller Kits

Wide Roller Kit for Non-Adjustable Birdcages. Includes bolts, wide spacers, and a wide roller. 1 kit required for each birdcage
BRP9582.....\$64.37
Wide Roller Only allows increased side to side movement of torsion bars/rear end when using left side panhard bar or left side frame mounted j-bar.
BRP9578.....\$46.09
Wide Roller Kit Adjustable Birdcage. Includes bolts, 2 laser cut spacers, and a wide roller. 1 kit required for each birdcage.
BRP9583.....\$64.37



J-Bar

1-1/2 Steel J-Bar. Hooks to right side of rear end with std BRP1626 mt & left side of chassis w/BRP9590 requires two 5/8 thread x 1/2 hole steel rod ends.
BRP9584.....\$125.36



Bicknell Linear Floor Slider

DIG30-000.....\$220.00



Linear Bearing Floor Slider High Fib

DIG30-001.....\$220.00



Floor Torque Arm Sliders

3/4" Steel Slider Rod (2 flats - 11 7/8" long)
2 Required
BRP421.....\$14.12
3/4" Alum Lock Collar
2 Required
BRP181-1A.....\$6.16



Rubber Biscuit Assembly (w/bolt, black rubbers, & rod ends).....BRP424.....\$115.19
Rubber Biscuit Assembly (w/bolt, black rubbers, & rod ends).....BRP424BL.....\$115.19
Rod End Only (2 1/4" from center of heim to end of threads).....BRP425.....\$52.91
Rubber Bushing Kit (w/2 washers, 2 black rubbers, & 1 sleeve).....BRP427.....\$45.52
Black Rubber Bushings Only - 70 Duro (sold each) 1 3/8" high.....BRP427-1.....\$16.80
Blue Rubber Bushings Only - 60 Duro (sold each) 1 3/8" high.....BRP427-5.....\$16.80
Red Rubber Bushings Only - 50 Duro (sold each) 1 3/8" high.....BRP427-2.....\$16.80
Short Blue Rub Bushings Only 60 Duro (sold each) 1 1/8" high.....BRP427-6.....\$16.80
Steel Washers Only.....BRP427-3.....\$5.61
Steel Inner Sleeve (2.50" long).....BRP427-4.....\$7.47
Stainless Steel Front Slider Shaft (w/BRP181A locking collar).....BRP419.....\$20.54
Midrail Aluminum Slider Plate - 4 1/4" center to center.....BRP418.....\$122.92

Rubber Floor Torque Arm Sliders

BRP417.....\$246.57

Steel Torque Arm Slider for Rubber Floor Cars 6 1/4" ctr to ctr.....BRP417S.....\$246.57
Replacement Inner Aluminum Sleeve with O'Rings.....BRP417-2.....\$17.57
Replacement Inner Sleeve End Cap - 4 required.....BRP417-3.....\$2.93
Inner Aluminum Cup.....BRP417-7.....\$20.61
3/4" Steel Slider Rod (has flats - 12 1/4" long) - 2 required.....BRP9115.....\$13.44
3/4" Aluminum Lock Collar - 4 required.....BRP181-1A.....\$6.16
Rubber Biscuit Assembly (w/bolt, black rubbers, & rod ends).....BRP424.....\$115.19
Rubber Biscuit Assembly (w/bolt, blue rubbers, & rod ends).....BRP424BL.....\$115.19
Rod End Only (2 1/4" from center of heim to end of threads).....BRP425.....\$52.91
Rubber Bushing Kit (w/2 washers, 2 black rubbers, & 1 sleeve).....BRP427.....\$45.52
Black Rubber Bushings Only (70 duro) - 1 3/8" high.....BRP427-1.....\$16.80
Blue Rubber Bushings Only (60 duro) - 1 3/8" high.....BRP427-5.....\$16.80
Red Rubber Bushings Only (50 duro) - 1 3/8" high.....BRP427-2.....\$16.80
Short Blue Rubber Bushing Only (60 Duro) - 1 1/8" high.....BRP427-6.....\$16.80
Steel Washer Only.....BRP427-3.....\$5.61
Steel Inner Sleeve (2 1/2" long).....BRP427-4.....\$7.47
Stainless Steel Front Slider Shaft (w/BRP181A locking collar).....BRP419.....\$20.54

Panhard Mt

Quick change inner panhard mount. Use BRP443 Bolt Kit.
BRP1626.....\$65.90

Panhard Bar Mt

Mounts to torque plate..BRP1624...\$69.58
Safety Cable.....BRP420.....\$13.37

Offset Torque Arm Slider

Machined from 6061 Alum. Slider pickup has 2 locations middle for medium to tacky tracks and left location for slick tracks. Very easy to change pickup location at the track.
For direct bolt in existing chassis. Will fit any midrail chassis. Kit comes complete ready to bolt in.
BRP9108.....\$191.34

Adj Panhard Mount

1-1/2" Tube
Has 5 Adjustment Holes. Includes Hardware & BRP 9369C Quick Pin.
BRP9369.....\$139.43

Torque Arm Thru Bolt Kit

Use w/BRP1626 Panhard Mt..BRP443...\$16.86
Use w/BRP1624 Panhard Mt..BRP442...\$16.86

Linear Bearing Slider Mount

TEOT008B.....\$306.15

Linear Slider Bearing - Each

TEOT008BR.....\$53.95

Torque Arm Biscuit Assy

TEOT024A03.....\$102.95

Aluminum Slider Mt Wide

TEOT00807.....\$144.95

Torsion Arm

19.5" Black...CTDNYM-020-A-BK...\$69.09

20.0" Black...CTDNYM-020-B-BK...\$69.09

CTDNYM-020-A-BK

CTDNYM-020-B-BK

Torsion Arms

18" Torsion Arm.....TEOPR00718B.....\$141.70

19.5" Torsion Arm.....TEOPR00719.5B.....\$141.70

Torsion Arms (roller end)

18" Red.....BRP4402.....\$108.40

18" Black.....BRP4402BK.....\$108.40

19.5" Red.....BRP4400.....\$108.40

19.5" Black.....BRP4400BK.....\$108.40

Safety Bolt.....BRP4403.....\$9.33

(Heavy Duty) (Black)

Left Rear 22" Long.....BRP9360.....\$110.48

Left Rear 23" Long.....BRP9522.....\$110.48

Right Rear 20-1/2" Long.....BRP9361.....\$100.44

Torsion Arm Dirt

Long.....SCHRARMDM4130L.....\$190.00

Short.....SCHRARMDM4130S.....\$190.00

Torsion Arm Roller Adjusting Tool

Works with any 2" Wide or Narrower Torsion Arm. Just Clip in Place and Jack Pressure off Roller
BRP9428.....\$50.16



Spring Rods Wrench included

Adjust rear spring with different spring rates.
 With 5/8" Ends 650 lb. Red.....BRP1399-650\$180.58
 With 5/8" Ends 650 lb. Black.....BRP1399-650BK\$180.58
 With 5/8" Ends 900 lb. Red.....BRP1399-900\$180.58
 With 5/8" Ends 900 lb. Black.....BRP1399-900BK\$180.58
 With 3/4" Ends 650 lb. Red.....BRP1398-650\$153.74
 With 3/4" Ends 900 lb. Red.....BRP1398-900\$153.74
 3/4" Spring Rod Wrench Red.....BRP1398W.....\$12.23
 5/8" Spring Rod Wrench Red.....BRP1399W.....\$12.23
 5/8" Spring Rod Wrench Black.....BRP1399WBK.....\$12.23

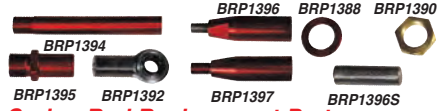

Spring Rod Replacement Parts

Description	3/4"	5/8"
Body (Red).....	BRP1397.....\$47.97	BRP1396.....\$45.52
Body (Black).....	BRP1397BK \$43.61	BRP1396BK \$45.52
Slider Housing (Red).....	BRP1395.....\$24.50	BRP1395.....\$24.50
Slider Housing (Black).....	BRP1395BK \$24.50	BRP1395BK \$24.50
Slider Rod (Red).....	BRP1394.....\$15.99	BRP1393.....\$15.99
Slider Rod (Black).....	BRP1394BK \$14.54	BRP1393BK \$15.99
Rod End (Red).....	BRP1392.....\$39.69	BRP1391.....\$31.97
Rod End (Black).....	BRP1392BK \$29.06	BRP1391BK \$29.06
Adjuster Nut (Red).....	BRP1390.....\$12.34	BRP1389.....\$12.34
Adjuster Nut (Black).....	BRP1390BK \$11.21	BRP1389BK \$11.21
Slider Washer (Red).....	BRP1388.....\$4.40	BRP1388.....\$4.40
Slider Washer (Black).....	BRP1388BK \$4.40	BRP1388BK \$4.40
Adjuster Washer (Red).....	BRP1387.....\$4.40	BRP1387.....\$4.40
Adjuster Washer (Bk).....	BRP1387BK \$4.40	BRP1387BK \$4.40
Rubber Travel Indicator	BRP1386.....\$call	
5/8" Stud.....	BRP1396S.....\$6.13	

Quick Change Rear Axles Gun Drilled

25 1/4".....BER208-C.....\$170.74
 28 1/4".....BER210.....\$170.74
 29 3/4".....BER211.....\$170.74
 31 1/8".....BER212.....\$170.74
 32 1/8".....BER213.....\$170.74
 33".....BER214.....\$170.74
 34 1/8".....BER215.....\$170.74
 35 1/8".....BER216.....\$170.74
 35 5/8".....BER217.....\$170.74
 36 1/8".....BER218.....\$170.74
 37".....BER220.....\$170.74
 38 1/8".....BER221.....\$170.74



Add "S" after the part # for Solid

26.....WIN5067-26.....\$99.99
 27 1/2".....WIN5067-2750.....\$99.99
 28 1/4".....WIN5067-07.....\$99.99
 29 3/4".....WIN5067-06.....\$99.99
 33.....WIN5067-33.....\$99.99
 33.5.....WIN5067-33.5.....\$99.99
 34.....WIN5067-34.....\$99.99
 36.....WIN5067-36.....\$99.99
 37.....WIN5067-37.....\$99.99
 38.....WIN5067-38.....\$99.99

Solid



25 1/2".....WIN5067-G-25.5.....\$134.99
 25 3/4".....WIN5067-G-25.3/4.....\$148.87
 26 1/4".....WIN5067-G-08.....\$134.99
 27.....WIN5067-G-27.....\$134.99
 28 1/4".....WIN5067-G-07.....\$134.99
 29 3/4".....WIN5067-G-06.....\$148.87
 31.....WIN5067-G-31.....\$134.99
 32.....WIN5067-G-04.....\$134.99
 33.....WIN5067-G-33.....\$134.99
 33 1/2".....WIN5067-G-33 1/2.....\$134.99
 34.....WIN5067-G-02.....\$134.99
 36.....WIN5067-G-36.....\$134.99
 37.....WIN5067-G-37.....\$134.99
 38.....WIN5067-G-38.....\$134.99



Gun Drilled

Hollow 31 Spline Axle

DMIRRC-2300-25.5.....\$154.72.....25.5"
 DMIRRC-2300-28.25.....\$144.50.....28.5"
 DMIRRC-2300-29.75.....\$154.72.....29.75"
 DMIRRC-2300-32.5.....\$154.72.....32.5"
 DMIRRC-2300-33.5.....\$154.72.....33.5"
 DMIRRC-2300-35.5.....\$154.72.....35.5"
 DMIRRC-2300-36.5.....\$154.72.....36.5"
 DMIRRC-2300-38.....\$154.72.....38"



Solid 31 Spline Axle

DMIRRC-2350-25.5.....\$122.25.....25.5"
 DMIRRC-2350-28.5.....\$122.25.....28.5"
 DMIRRC-2350-29.75.....\$122.25.....29.75"
 DMIRRC-2350-30.5.....\$122.25.....30.5"
 DMIRRC-2350-31.....\$122.25.....31"
 DMIRRC-2350-31.5.....\$122.25.....31.5"
 DMIRRC-2350-32.5.....\$122.25.....32.5"
 DMIRRC-2350-33.5.....\$122.25.....33.5"
 DMIRRC-2350-35.....\$122.25.....35"
 DMIRRC-2350-35.5.....\$122.25.....35.5"
 DMIRRC-2350-36.....\$122.25.....36"
 DMIRRC-2350-36.5.....\$122.25.....36.5"
 DMIRRC-2350-38.....\$122.25.....38"



Aluminum Spring Rods w/850 Spring

TEOTM107-850.....\$159.29
Mini Springs HYPERCOILS
 Rate: 650 Free Height: 4 1/2".....HYP184.5H0600...\$41.55
 Rate: 900 Free Height: 4 1/2".....HYP184.5H0900...\$41.55



Rear End Assembly 10 HD Wide 5 Mag..WINK5270..\$1,331.95

Popular Options:

Pinion Support Option.....WIN9139\$70.00
 Option Race Flanged Pinion.....WIN8191\$44.10
 Option Pinion Posi-Lock Assembly.....WIN8104\$26.56
 Option Shaft Lower Heat Treated.....WIN8106\$28.46
 Option Bearing Roller Pinion Nose.....WIN8143\$18.38
 Option Ring & Pinion 4.11 Short.....WIN8111-8S-6.....\$286.00
 3rd Gen 6 Bolt Cover.....WIN8133-8S-6.....\$104.00
 Option Ring Gear EDM 4:12.....WIN8202-V8.....\$422.50
 Option Thermal Dispersant.....WIN8208\$207.90
 Option Ring & Pinion REM.....WIN8218-RP.....\$113.40
 8" Rear Cover Option.....WIN8252B.....\$123.50
 Option Seals Closed Tube Viton.....WIN8298.....\$5.60
 Option Differential Pool Ultralight Alum.....WIN8130.....\$42.53
 8 Rib HD Bell Opt.....WIN8155PMHD \$76.28

Axle Tube Options:

Option Tubes 8 Bolt Aluminum.....WIN8132\$275.52
 Smart Tube Option.....WIN8239\$135.00
 Splined Rear Axle Tube Option.....WIN8238\$162.00
 Tetrad.....WIN9119.....\$269.06

Coil Over

Shock Mount Assembly for Asphalt

Red.....BRP9061.....\$150.64
 Black.....BRP9061BK.....\$136.95



Custom Lengths Available!

Teo

Ground Strap Frame to Motor Plate
 6.5" Cable.....QUA802-0633BK.....\$10.15
Ground Strap Battery to Frame
 7" Cable.....QUA802-0733BK.....\$11.86
Battery Discount to Starter
 20" Cable.....QUA802-2053RDC.....\$16.56
Battery to Discount Switch
 37" Cable.....QUA802-3733RDC.....\$21.46

Bicknell

Ground Strap Battery to Frame
 14" Cable.....QUA802-1433BK.....\$14.04
Battery Discount to Starter
 20" Cable.....QUA802-2053RDC.....\$16.56
Battery to Discount Switch
 52" Cable.....QUA802-5233RDC.....\$25.78

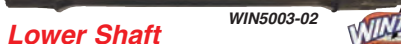

Lower Shaft

Standard Shaft, Open Drive.....WIN5003-02.....\$108.95
 Heat Treated Shaft, Open Drive.....WIN5003.....\$124.95

10" 8 Rib

8 Rib Bell (Left)
 WINK5016-02.....\$219.95

Closed Tube Bells

8 Rib Bell w/Insp. (Right)
 WINK5016-03.....\$240.95

8 Rib Bell
 L.W. (Left)
 WINK5016-02M.....\$235.95

8 Rib Bell
 L.W. w/Insp (Right)
 WINK5016-05.....\$257.95

10" 6 Rib
 6 Rib Bell (Left)
 WINK1663-02.....\$219.65

6 Rib Bell
 w/Insp (Right)
 WINK1663-01B.....\$240.95

10" 4 Rib
 4 Rib Bell (Left)
 WINK6697-02.....\$219.95

4 Rib Bell
 w/Inspection
 (Right)
 WINK6697-01B.....\$240.95

Side Bell O-Ring Seals

Thin for 6-rib bells.....WIN7403T.....\$8.41
 Thick for 8-rib bells.....WIN7403.....\$8.41

Rear Gear Covers

Solid Cover with large single ball bearings. Magnesium.
 WINK6508.....\$163.95

Replacement Bearing
 WIN7332.....\$35.99

Magnesium Sprint Center Gear Cover
 (Large Ball Bearing.)
 WINK3736.....\$190.95

Replacement Bearing
 WIN8659.....\$38.95

Cover w/removable plate for easy bearing access. Single row ball bearings. Aluminum.
 WIN6746.....\$138.95

Replacement Bearing
 WIN7524.....\$33.22

Sprint Center Gear Cover
 6 Bolt Short
 WIN12070.....\$273.00

Replacement Bearing
 WIN8659.....\$38.95

Rear Cover Nuts

Black Aluminum.....WIN7794ASBK \$2.94
 3/8-16 x 1 3/4" Stud.....WIN7802.....\$2.13

Quick Change Gear Cover

Fasteners

7075 Billet Alum Construction. One-Piece Washerless Design. Cross-Drilled for Weight Savings & Safety Wiring
 JOE34358.....\$62.95



Oil Rear Lube w/Moly

Semi-Synthetic
 80-90-140 w/moly 1 gallon
 WIN1730.....\$45.95



Rear Cover Gaskets

Standard
 WIN6729.....\$3.50

Steel Shim
 WIN6729HD.....\$6.93

Rear Cover Gaskets

Steel reinforced non-stick gasket is a must when replacing gears.
 FEL2303.....\$8.52



Inspection Plugs

Quick change side oil level plug
 BRP908.....\$23.36

1" hex head makes it easy to remove plug from center section to inspect.
 BRP909.....\$23.95



Bearing Ball

Lower Shaft - Front
 WIN7390.....\$17.21

Lower Shaft
 Shielded Bearing - Rear
 WIN7339.....\$16.04



Quick Change Alum Spools

These alum spools fit Winters quick change rears. Available in regular or Ultralight.
 Alum. Spool.....WIN5034-11A.....\$238.95
 Ultralight Spool.....WIN5034-11UL \$273.95
 Spool Seals.....BEA7205.....\$5.22
 Alum. Spool Bearings.....WIN7340.....\$20.61
 Shim Kits.....WIN5295.....\$6.65



Quick Change Ring & Pinion

We sell Winters ring and pinions with ball bearings ready to install. Available are the Roller Bearing and the Posi-Lock options. Just add those part numbers.



4:12 R&P.....WIN515W8104-8143-8218.....\$512.95
 4:86 R&P.....WIN5401/8218/8143/8104.....\$471.95

Front Spoiler

Aluminum Wedge Style

Flat NoseBRPBRB2950.....\$187.24
 1-1/2" Raised NoseBRPBRB2950-1.5.....\$187.24

Aluminum Flat Style

Std Nose 1" Offset Flat.....BRPBRB2012FSPOILER.....\$147.87
 1-1/2" Raised Nose 1" Offset Flat..BRPBRB2013-1.5.....\$169.47



Rear Bumper After 7/25/00 26-1/2" center to center

StandardBRP7111.....\$180.72
 Chrome.....BRP7111C.....\$391.50

2000X and

Newer Side Bumpers

Rear Inner Side Bar Post.....BRP7100.....\$23.90
 Rear and Left Middle Hoop.....BRP447.....\$32.62

Connectors for BRP447 to BRP7100

LeftBRP7113.....\$25.67
 Right.....BRP7114.....\$25.67
 Right Outer Side Bar.....BRP7101.....\$45.58
 Right Outer Side Bar Chrome.....BRP7101C.....\$126.88
 Left Outer Side Bar.....BRP7102.....\$41.89
 Left Outer Side Bar Chrome...BRP7102C..\$126.88

Double Rail Sidebars

Right Side...BRP7129...\$79.46
 Left SideBRP7128...\$75.77

52" Dirt Modified Front Axles

Bicknell Unpainted....BRPEC52BOC.....\$275.24
 Bicknell Black.....BRPEC52BOC-03.....\$348.78
 TEO.....TEOT007.....\$295.10

Front Axle Checking Tool

Easily Check Front Axles for Being Straight or Bent
 BRP9432.....\$55.75

Front Bumpers 2 Stage

Standard ..TEOTC1501.....\$74.10
 Wide.....TEOTC1501W.....\$81.37

Rear Bumper 2 Stage

Long (9-1/2")..TEOTC1502...\$179.40

Side Rub Rails - Std

Left Side.....TEOTC1503L.....\$45.50
 Right Side.....TEOTC1503R.....\$45.50

Side Rub Rails Short Track

Left Side.....TEOTC1503LS.....\$98.80
 Right Side.....TEOTC1503RS.....\$98.80

Body Panels



Wheel Well Tub

Short - WhiteTRIW1.....\$69.95
 Medium - WhiteTRIW3.....\$69.95
 Medium - Black or RedTRIW3-(Color).....\$74.95
 Long - WhiteTRIW2.....\$69.95
 Long - Black or RedTRIW2-(Color).....\$74.95

Medium Cowling

Medium WhiteTRICO2.....\$88.95
 Medium Bk Blue RedTRICO2-(Color).....\$96.95
 BRP Style Cowl White.....TRICOBWP-WHITE.....\$97.50
 BRP Style Cowl Bk Blue Red.....TRICOBWP-(Color).....\$109.50

Hood Smooth

WhiteTRIO2.....\$171.95
 Black, Blue, or RedTRIO2-(Color).....\$186.95
 Ram Air Hood.....TRIO3.....\$187.60
 New Design Hood Scoop.....TRIO5.....\$173.60
 Teo Hood Scoop.....TRIO7.....\$105.00
 Oil Cooler Ram.....TRIO12.....\$63.00

Engine Hood Tail Filter 18" Engine

WhiteTRIO6.....\$172.95
 Black, Blue, or RedTRIO6-(Color).....\$186.95

TRIOBRPSBS-WHITE TRIOBRPSBL-WHITE

TRIOBRPBBS-WHITE

TRIOBRPBBL-WHITE

TRIOBRPBBSX-WHITE

TRIOBRPBBSX-WHITE

TRIOBRPBBSX-WHITE

TRIOBRPBBSX-WHITE

BRP Hood for a Small Block

Short w/Full Bottom White.....TRIOBRPSBS-WHITE.....\$199.50
 Short w/Full Bottom Bk Blue Red...TRIOBRPSBS-(Color).....\$213.75
 Long Old Style - White.....TRIOBRPSBL-WHITE.....\$199.50

BRP Hood for a Big Block

Short Hood-Cut Alum Base White...TRIOBRPBBSX-WHITE.....\$199.50
 Short Hood w/Full Bottom White.....TRIOBRPBBS-WHITE.....\$199.50
 Short Hood w/Full Bot Bk Blue Red...TRIOBRPBBS-(Color).....\$213.75
 Long w/Full Bottom - White.....TRIOBRPBBL-WHITE.....\$199.50
 Long Hood Offers Clearance for
 Expansion Tank-Cut for Alum Base TRIOBRPBBLX-WHITE.....\$199.50

Midrail Front Bumper

1-1/4" pocket style. 98 & newer chassis.

Stock.....BRP464.....\$86.24

Unpainted Std Front Bumper for 1-1/2" Raised Front Nose**
 (Not Chrome)**..BRP464-1.5.....\$86.24

Front Bumper for Modified (Chrome) Top Rail is 3" Higher Than a Standard

BRP464.....BRP464TC.....\$226.10

Unpainted Tall Fr Bumper for Modified*(Not Chrome)*...Tall BRP464T.....\$104.27

Unpainted Tall Fr Bumper for 1-1/2" Raised Front Nose*(Not Chrome)*..BRP464T-1.5.....\$104.27

Nerf Bar Grommet Seal-1 1/2" I.D.-6" O.D. Seals-it

When using a oversize hole in the body panels, where the Nerf bar passes thru, gives the Nerf bar more clearance for movement when the Nerf bar gets bent..SEANBGS15..\$14.90

Rear Body Supports

Midrail Lower Qtr Panel Body Mts

Left Side.....BRP7103.....\$28.44
 Right Side ..BRP7104.....\$28.44

Roof Mounts

Midrail Front Roof Mount.....BRP7108.....\$33.93
 Midrail Rear Roof Mount.....BRP7109.....\$33.93
 Roof Mount Extensions.....BRP7112.....\$6.41

Straight Door Supports

Mid Rail Left Side Door Mount.....BRP7105S...\$40.84
 Mid Rail Right Side Door Mount...BRP7106S...\$33.93

Door Supports

Left Side.....BRP7105...\$33.93
 Right Side ..BRP7106...\$33.93

Window Screens

Mid Rail Screen (26-1/2" x 11-1/4").....BRP7107B.....\$86.50
 Mid Rail Tall Cage Screen (26-1/2" x 14-1/4").....BRP7119.....\$84.81
 Mid Rail Tall Cage Screen (26-1/2" x 14-1/4").....BRP7119-1X2...\$84.81

Teo Window Screens

For Tall Cage...TEOT039.....\$53.30
 NotchedTEOT039N.....\$53.30

Set Up Stands

Left Front (4-7/16").....BRP1553...\$13.07
 Right Front (3-11/16")..BRP1552...\$13.07
 Left Rear (4-1/4").....BRP1538...\$13.07
 Right Rear (3-3/4").....BRP1539...\$13.07

Rear Engine Plate

BBC and SBC Narrow Frame (Mid-Rail)
 BRP292.....\$238.47

Front Clip

Is the complete front clip less 2x4's. includes radius rod posts as well as radius rod post braces. Floor is complete excluding the 2x4.
 Stock Clip.....BRPFCLIP3.....\$1400.23

Rear Clip

For 2000X or newer.
 BRPRCLIP1.....\$163.47

Spoiler Mts

2000X Mid Rail Front Spoiler Side Mount
 Left Side (5/8" Tubing).....BRP7110.....\$6.41

2001 and Newer Mid Rail

Right Spoiler Mount (5/8" Tubing) ..BRP7110R...\$6.41

Ultra Strong Bolt On Shock Tower

Made from Ultra Strong 2024 Alum. Solid, but still weighs in at 1.8 lbs. Direct replacement for our CHA 100BO steel bolt on shock tower. Pre-drilled for quick replacement at the track or shop. Bolts and seals for rear end aren't included****

BRP9262.....\$44.57

This is 1" Longer Than BRP9262 for Longer Shocks

BRP9431.....\$44.57

Shock Tower

LF/RF..BRPCHA100..\$21.80

Front Shock Tower

CTDNM-026..\$53.13

Front Shock Tower

Replacement Teo Front Shock Tower Bolt-In.
 TEOT021.....\$48.75

Body Brace Mount for 1-1/2" Pipe

Fits 1-1/2" frame and accepts a 1/2" steel tube. Use in conjunction with BRP9477 roof support or any other custom fabricated support you like. These make a great addition for body support without any welding required on the chassis.

BRP9457.....\$25.32

Listing for Left Pan Hard Bar & Short Rod Mills/ Watt Style Left Pan Hard Inboard @ Rear End

Left Inboard Pan Hard Mount BRP1626L
 For Rear End Housing BRP1626L \$72.49
 Top threaded rod for ability for BRP1626 & BRP1626L to be mounted BRP9563 \$26.10
 Left Rear Pan Hard Bar BRP1120BK \$17.65



Outboard at Frame

Outboard at Frame BRP4550L \$143.99

Mounting Hardware

Thru Slug BRP1511 \$4.90
 Tapped Slug BRPCHA207 \$7.11
 Weld-On Lower Mount BRPCHA527 \$34.20
 Drop 2" Drop Rail BRPCHA142LL \$38.00
 Rear Floor Brace BRPCHA275 \$29.53

Left Rear Radius Rod Adaptor Plate

(has 6 holes on radius) BRP9099L-1
 (7.5" Shorter Radius Rod)
 Left BRP9099L-1 \$167.63

Right Rear Radius Rod Adaptor Plate

(has 3 holes on radius) BRP9099R-1
 (7.5" Shorter Radius Rod)
 Right BRP9099R-1 \$133.75

Right Rear Tubing Support for Bkt

BRP9099R-1B \$71.15

Radius Rods for

Short Rod and Left Pan Hard

Left Rear Radius Rods for short rod (1)
 17" 1-1/4" Radius Rod BRPRR17BK \$21.74

Right Rear Radius Rods for short rod (1)
 18" 1-1/4" Radius Rod BRPRR18BK \$22.64

Rear Coil Over Steel Wedge Bolt Kits
 (Mount to Rear Shock Towers of std Bicknell
 1.25" Tube) (2) BRP9560 \$150.64

Rear Trailing Arm Mounts for Quad Lock Tubes Only and
 Coil Spring Application (2) BRP9469 \$167.03

Rear Trailing Arm Mounts Adaptor Brackets Bolts
 to BRP9469 (2) BRP9549 \$133.75

Wide Roller Kits

Wide Roller Kit for Non-Adjustable Birdcages. Includes bolts,
 wide spacers, and a wide roller. 1 kit required for each birdcage
 BRP9582 \$64.37

Wide Roller Only allows increased side to side movement of torsion bars/rear end
 when using left side panhard bar or left side frame mounted j-bar.
 BRP9578 \$46.09

Wide Roller Kit Adjustable Birdcage. Includes bolts, 2 laser cut
 spacers, and a wide roller. 1 kit required for each birdcage.
 BRP9583 \$64.37

J-Bar

1-1/2 Steel J-Bar. Hooks to right side of rear end w/std BRP1626 mt & left side
 of chassis w/BRP9590 requires two 5/8 thread x 1/2 hole steel rod ends.
 BRP9584 \$125.36

Panhard

Cockpit Adjustable Left Side Panhard (Silver) BRP9588 \$400.40
 Non-Adj Left Side J Bar Mt Panhard (Silver) BRP9590 \$143.99

Drop Down Coil Over Mount

Drop down coil over mount for left rear or right rear short link cars.
 An alternative to the version with the weight jack screw assembly.
 BRP9574 \$135.52

Torque Arm Plates Sold Each

28" x 32 1/2" Thickness: 3/8", -3" (New torque arm for
 transmission clearance for 2" motor set back cars.
 BRP9295 \$110.71

Radius Rods

12" x 1" Polished 5/8" RH & LH Tap RAD0120M \$13.69
 17" x 1.25" Polished 5/8" RH & LH Tap RAD1170M \$20.66
 18" x 1.25" Polished 5/8" RH & LH Tap RAD1180M \$21.16

Left Rear Speed Chain Assembly

Stops the suspension's travel before the shock reaches full extension.
 Adjusts the total amount of allowable chassis roll. Being able to easily
 adjust this can help achieve a more balanced race car. Maintains load
 at the left rear tire by limiting how far the torsion bar/spring can extend.
 The more it extends the "lighter" the tire becomes. 1.5" Dia Mt Bkt, 3.0"
 Axle Tube Mount Bkt, Left Rear Speed Chain Housing, 24" of 3/16
 Chain (Yield strength of 2,400 lbs), 24" of black shrink wrap.
 DIG54-000 \$250.00

**Bicknell Linear
 Floor Slider**
 DIG30-000 \$220.00

**Linear Bearing
 Floor Slider Hig Fab**
 DIG30-001 \$220.00



12" Heat Shrink Sleeve for Chain

WEHWM314S \$5.00

12" Limit Chain

WEHWM314C \$11.20

Suspension Limiter

Single bushing suspension limiter is commonly used on the chassis LR
 or RR to limit travel during acceleration "hike up" and control roll steer. Double
 bushing limiter is often used on the lift bar to control lift bar travel on deceleration.
 Top plate is drilled to attach a 1/2" rod end when used in a shock mount
 or for attaching to a weight jack bolt with 7/16"-20 internal threads using optional
 chrome moly stud ALL64304. Clevis has a 3/8" hole.

Single Bushing Limiter ALL64300 \$77.99
 Dual Bushing Limiter ALL64302 \$91.99



Limiter Chain Kit

Commonly used to limit rear suspension or lift bar travel. 3/16" x 18" long chain link will accept
 a 3/8" bolt or pin but may be modified to accept up to a 1/2" bolt. Chain can be easily cut to
 required length. Shrink sleeve installs over chain and when heated with a heat
 gun shrinks to keep chain in position and prevent from binding or catching
 on itself.

3/16" Dia. Accepts 3/8" Pin or Bolt ALL64312 \$7.49
 5/16" Dia. Accepts 1/2" Pin or Bolt ALL64314 \$8.99



Axle Tube Bracket

Bracket clamps around 3" axle tubes providing a mounting point for a suspension
 limiter such as a limiting strap or chain. 1" wide bkt has tabs with 1/2" holes.
 ALL68324 \$19.99

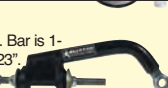

J-Bar Panhard Bar w/Rubber Center

It has a rubber center to cushion side loading and improve handling. Bar is 1-
 1/2" dia. steel tubing. Center-to-center length adjusts from 18-1/2" to 23".
 ALL56157 \$109.99



Cut-To-Fit J-Bar Style Panhard Bars

It is an unwelded kit offering the ability to build a custom length J-Bar with up to a 27" long center
 to center distance, enough to work with most chassis. Bar is formed from .250" wall 1-1/2" steel
 tubing, has a 4" drop, includes a threaded insert and rod ends.
 ALL56141 \$78.99

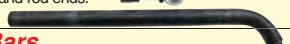

Adjustable J-Bar Panhard Bars

Bars are formed from 1-1/2" steel tubing and mount to the pinion rather than the axle tube to
 maintain adequate driveshaft clearance. J-bars have 3/4" rods ends and allow up to 2" of
 adjustment. 6.2 lbs.

4" Drop, 17-1/2"-19-1/2", J-Bar Panhard Bar ALL56155 \$104.99
 4" Drop, 19-1/2"-21-1/2", J-Bar Panhard Bar ALL56156 \$104.99

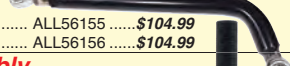

Coil-Over Load Bolt Assembly

Threaded bolt is 6" long with 1-1/8"-12 fine threads and is commonly used on big
 bar soft spring cars. Load bolt offers the ability to easily change corner weights,
 change the center to center distance of the shock, adjust bump stop distances with-
 out adding shims and adjust ride height without running out of shock travel.
 ALL56074 \$44.99



Weight Jack Bolt Collars 1-1/8"-12

Steel collar typically welds onto frame or chassis for installation of a threaded jack
 bolt. Collar includes grease fitting.
 ALL56098 \$9.99



1-1/8"-12, Fine Thread Weight Jack Bolt Sleeves

Weld-in mild steel sleeve provides a mounting point for jack bolts or adjustable shock
 mounts. Sleeves are 2" long and have a 1-3/8" O.D. for welding into chassis tubing.
 ALL56073 \$11.99

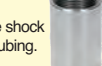

Alum. Q/C Pinion Mt

Single side quick change pinion mount with
 climber on an arc. Slot goes 1-1/2" below pinion centerline. Climber hard-
 ware included WEHWM205 \$133.00



Alum. Double Sided Q/C Pinion Mt

Same arc as our WM205 with the extra arc slot on left side of the
 pinion. Mt adjusts easily with our climber nut. All hardware.
 WEHWM205DS \$147.00



Steel Quick Change Pinion Mt

Our new billet steel QC pinion mt. This profile matches our WM219
 mount and is machined with the seal installed in it to eliminate the seal
 plate like our std steel mounts use. Comes with climber gear hardware.
 WEHWM419 \$160.00



J-Bars

Superior in strength, adjustability, and versatility to any other brand on the market.
 Fits any chassis. Adjust the bar length 2" without disconnecting from the frame.

Alum. 19-21 Std 4" Drop WEHWM4019-21 \$170.00
 Alum. 20-22 Std 4" Drop WEHWM4020-22 \$170.00
 Steel 19-21 Dbl Adjustable WEHWM40S19-21 \$115.00
 Steel 20-22 Dbl Adjustable WEHWM40S20-22 \$115.00



Suspension Travel Limit Chain Holder w/Bearing

Here is our new no-bind suspension limit chain holder bearing. This allows your chain to stay
 free through suspension travel. This one has an aluminum housing and
 clamp rings. This is a complete kit with clamp rings.
 WEHWM210AK \$85.00



Limit Chain Axle Clamp

Limit chain clamp for 3" axle tube with double shear tabs.
 WEHWM293 \$28.00



Limit Chain w/Belleville Spring

Our new Brad Waits designed quick change limit chain adjuster allows you to change your
 chain length by simply pulling a pin, moving to the next hole and inserting the pin.
 You can make a chain adjustment in seconds with no tools. The limit chain adjuster also
 has a Belleville spring stack to give you a cushion at the
 end of the chain to keep your tire on the track.
 Quick Adjust 1-1/2" Limit Chain w/Spring
 WEHWM269150A \$85.00
 Bolt In Steel Quick Adjust Mount w/Spring
 WEHWM269BSW \$80.00





The CT-1

The CT-1 is the premier rear available for closed tube applications. The CT-1 is the latest product available from Bulldog Rears. Since 2004, Bulldog has become the "Choice of Champions" in the sprint car market.

What our competitors call options - we call standard equipment. From high quality castings, bearings and seals to the most user friendly rear available, Bulldog is your choice for reliability and performance. The CT-1 is available in 4.86 or 4.12 ratios and with six or eight rib side bells. Get a CT-1 today to see why they are "The Choice of Champions!"

Standard Features of The CT-1 Include:

- Breather Assembly
- Correct length through bolts for your application
- Three side bells studs per side allow for easy side bell removal without complete disassembly
- Magnetic Drain Plug
- 8 AN port for fill can applications
- Heat treated lower shaft
- Billet Gear Cover with O-ring Seal
- Posi Lock
- Pinion Nose Roller Bearing
- Right Side Bell with Inspection Plug
- **The best customer service in the business!**



Complete Closed Tube Rarends

Bulldog CT-1 4.86 Complete Magnesium Rear (less tubes)...DMICT1-486..**\$1696.98**

Bulldog CT-1 4.12 Complete Magnesium Rear (less tubes)...DMICT1-412..**\$1696.98**

Choose Options in the Blue Box to the right.

Comes with 5 FREE Quarts of Bulldog Blood Gear Oil when you buy a Complete Closed Tube Rarend!



DMI Rear Options

Closed Tube Rarend Options (Pick Your Options Below)

- DMI1-A ..\$171.84..Black Thermal Coating - 6 Rib
- DMI1-B ..\$171.84..Black Thermal Coating - 8 Rib
- DMI1-C ..\$171.84..Black Thermal Coating - 8 Rib Right Side / 6 Rib Left Side
- DMI1-D ..\$171.84..Black Thermal Coating - 8 Rib Left Side / 6 Rib Right Side
- DMI1-E ..\$68.74.....Black Thermal Coating - Center Only
- DMI1-F ..\$103.10..Black Thermal Coating - Side Bells Only - 8 Rib
- DMI1-G ..\$103.10..Black Thermal Coating - Side Bells Only - 6 Rib
- DMI1-H ..\$103.10..Black Thermal Coating - Side Bells Only - 8 Rib RS / 6 Rib LS
- DMI1-I.....\$103.10..Black Thermal Coating - Side Bells Only - 8 Rib LS / 6 Rib RS

- DMI2-A ..\$171.84..EDM Ring Gear
- DMI2-B ..\$123.73..Polish Ring & Pinion
- DMI2-C ..\$295.56..EDM / Polish Ring and Pinion

- DMI3-C ..\$109.98..Aluminum End Yoke
- DMI3-D ..\$27.49.....Heat Treated Lower Shaft

- DMI4-A ..\$75.54....Front Seal Plate - Standard
- DMI4-B ..\$75.54....Front Seal Plate - w/o 2 Counterbores
- DMI4-C ..\$75.54....Front Seal Plate - w/o Counterbores

- DMI5-A ..\$27.49....8-Rib Side Bells - Both Sides
- DMI5-B ..\$13.75....8-Rib Side Bells - Right Side Only
- DMI5-C ..\$13.75....8-Rib Side Bells - Left Side Only

- DMI6-A ..\$75.61....Low Drag w/Teflon Lip Seals & Severe Duty Bearings
- DMI6-B ..\$82.48....Low Drag w/Teflon Lip Seals & Severe Duty Bearings w/Seal Plate Seal
- DMI6-C ..\$27.49....Low Drag Seals Only
- DMI6-D ..\$34.37....Low Drag Seals Only w/ Seal Plate Seal
- DMI6-E ..\$27.49....Severe Duty Spool Bearings
- DMI6-F ..\$20.62....Severe Duty Lower Shaft Bearings
- DMI6-G ..\$48.11....Severe Duty Bearings - All

- DMI7-ADIRT Modified Thru Bolts
- DMI7-BDIRT Modified Thru Bolts w/ 4B Seal Plate
- DMI7-CDirt Late Model Thru Bolts

- DMI8-A ..\$240.57..Include SmartTube Style Tubes - Specify Lengths
- DMI8-B ..\$412.42..Include Splined Teo Style Tubes - Specify Lengths
- DMI8-C ..\$433.04..Include Wide 5 Tubes - Specify Lengths
- DMI8-D ..\$439.91..Include Aluminum 8-Bolt Tubes - Specify Lengths
- DMI8-E ..\$549.89..Include HD Wide 5 - Specify Lengths
- DMI8-F ..\$543.02..Include SmartTubes - BRP Quadlock - Specify Lengths

- DMI9-A ..\$34.37....UltraLight Aluminum Spool
- DMI9-B ..\$687.37..Locker Diff
- DMI9-C ..\$54.99....Steel Spool

DMI Rear Race Components Parts



DMIRRC-1102-01 DMIRRC-1103-01 DMIRRC-1104 DMIRRC-1105
DMIRRC-1104T DMIRRC-1104T

- DMIRRC-1102.....\$272.65..CT-1 Mag Left Side Bell - 6 Rib
- DMIRRC-1102-01 ..\$324.23..CT-1 Mag Left Side Bell - 6 Rib -Black Thermal Coated
- DMIRRC-1103.....\$257.91..CT-1 Mag Right Side Bell - 6 Rib
- DMIRRC-1103-01 ..\$309.49..CT-1 Mag Right Side Bell - 6 Rib -Black Thermal Coated
- DMIRRC-1104.....\$6.20.....CT-1 Side Bell Axle Seal
- DMIRRC-1104T ..\$22.05.....CT-1 Side Bell Axle Seal - Teflon Lip
- DMIRRC-1105.....\$7.30.....Side Bell O-Ring



- DMIRRC-1411.....\$16.16....CT-1 Lower Shaft Bearing
- DMIRRC-1412 ..\$38.50....CT-1 Lower Shaft Bearing - Severe Duty
- DMIRRC-1427 ..\$147.34..CT-1 Steel Lower Shaft
- DMIRRC-1427HD ..\$184.20..CT-1 Steel Lower Shaft Heavy Duty Ground Finish
- DMIRRC-1620 ..\$1.42.....Lower Shaft Snap Ring



- DMIRRC-1479 ..\$44.15....CT-1 Front Yoke
- DMIRRC-1480A ..\$176.82..CT-1 Front Yoke - Aluminum
- DMIRRC-1481 ..\$5.82.....CT-1 Front Yoke Washer
- DMIRRC-1482 ..\$2.22.....CT-1 Front Yoke Bolt
- DMIRRC-1483 ..\$7.75.....CT-1 U-Bolts w/ Nuts (2pk.)
- DMIRRC-1485 ..\$6.28.....Aluminum Spacer for under CT-1 Front Yoke



- DMIRRC-1107.....\$287.39..CT-1 Mag Left Side Bell - 8 Rib
- DMIRRC-1107-01 ..\$338.98..CT-1 Mag Left Side Bell - 8 Rib Black Thermal Coated
- DMIRRC-1108.....\$272.65..CT-1 Mag Right Side Bell - 8 Rib
- DMIRRC-1108-01 ..\$324.23..CT-1 Mag Right Side Bell - 8 Rib Black Thermal Coated
- DMIRRC-1171.....\$21.46....CT-1 Side Bell Bearing for Alum Spool
- DMIRRC-1270 ..\$294.75..CT-1 Alum Spool
- DMIRRC-1271 ..\$331.61..CT-1 Alum Spool - UltraLight
- DMIRRC-1276 ..\$25.00....CT-1 Spool Shim Kit 3 each-.010,.012,.015,.020



Hollow Steel Driveshaft 32-32 Spline - 20..DMISRC-2467-32..\$212.70



- U-Joint Yoke - Long Steel Billet U-Joint Yoke - Long 32 Spline DMISRC-2342-32..\$191.30

DMI REAR RACE COMPONENTS PARTS



DMIRRC2275



DMIRRC-2275-26.62B\$254.51.....CT-1 Spindle Style Alum Axle Tube - 26.625"
 DMIRRC-2275-28.12B\$254.51.....CT-1 Spindle Style Alum Axle Tube - 28.125"
 DMIRRC-2275-29.12B\$254.51.....CT-1 Spindle Style Alum Axle Tube - 29.125"
 DMIRRC-2275-30.12B\$254.51.....CT-1 Spindle Style Alum Axle Tube - 30.125"
 DMIRRC-2275-34B\$254.51.....CT-1 Spindle Style Alum Axle Tube - 34"



DMIRRC2280



DMIRRC-2280-15B.....\$265.27.....CT-1 Aluminum 8-Bolt Tube - 15"
 DMIRRC-2280-16.5B.....\$265.27.....CT-1 Aluminum 8-Bolt Tube - 16.5"
 DMIRRC-2280-22.62B.....\$265.27.....CT-1 Aluminum 8-Bolt Tube - 22.625"
 DMIRRC-2280-24.75B.....\$265.27.....CT-1 Aluminum 8-Bolt Tube - 24.75"



DMIRRC2200



DMIRRC-2200-20.18B...\$142.26..CT-1 SmartTube Style Axle Tube - 20.188"
 DMIRRC-2200-22.18B...\$142.26..CT-1 SmartTube Style Axle Tube - 22.188"
 DMIRRC-2200-24.12B...\$142.26..CT-1 SmartTube Style Axle Tube - 24.125"
 DMIRRC-2200-24.62B...\$142.26..CT-1 SmartTube Style Axle Tube - 24.625"
 DMIRRC-2200-28.06B...\$142.26..CT-1 SmartTube Style Axle Tube - 28.060"
 DMIRRC-2200-30.12B...\$142.26..CT-1 SmartTube Style Axle Tube - 30.125"
 DMIRRC-2200-34B.....\$142.26..CT-1 SmartTube Style Axle Tube - 34"
 DMIRRC-2205-2206.....\$16.78....Steel Sleeve for SmartTube Style Tube



DMIRRC2250



DMIRRC-2250-20.18B...\$228.42..CT-1 Splined SmartTube Style Axle Tube 20.188"
 DMIRRC-2250-22.18B...\$228.42..CT-1 Splined SmartTube Style Axle Tube 22.188"
 DMIRRC-2250-24.12B...\$228.42..CT-1 Splined SmartTube Style Axle Tube 24.125"
 DMIRRC-2250-24.62B...\$228.42..CT-1 Splined SmartTube Style Axle Tube 24.625"
 DMIRRC-2250-28.06B...\$228.42..CT-1 Splined SmartTube Style Axle Tube 28.060"
 DMIRRC-2250-30.12B...\$228.42..CT-1 Splined SmartTube Style Axle Tube 30.125"



Bulldog Blood 75w-90 Gear Oil

Bulldog Blood 75w90 Synthetic Racing Gear Oil is track tested to meet the high demands placed on today's ring and pinions. Bulldog Blood from DMI is a proprietary formula that features extreme pressure additives that aid in the prevention of micro-pitting and excess wear. Bulldog Bloods non-foaming formula lowers operating temperature and is the only choice when it comes to high performance gear oil. The special additives in Bulldog Blood treat the metal and dramatically increases gear life.

1 Gallon.....DMIBULLDOG1.....\$60.05
 5 Gallon Pail.....DMIBULLDOG5.....\$295.36
 1 Quart.....DMIBULLDOGQT.....\$15.37



DMIRRC1350

DMIRRC1361B

DMIRRC1386B

DMIRRC-1350.....\$25.04....Rear Cover Bearing
 DMIRRC-1355.....\$1.42.....Rear Cover Stud
 DMIRRC-1361.....\$7.30.....Rear Cover High Nut - Black
 DMIRRC-1361B...\$7.30.....Rear Cover High Nut - Blue
 DMIRRC-1361G...\$7.30.....Rear Cover High Nut - Gold
 DMIRRC-1386G...\$216.64..Billet Alum Rear Cover w/ Bearings - Gold
 DMIRRC-1386B...\$216.64..Billet Alum Rear Cover w/ Bearings - Black
 DMIRRC-1390.....\$8.36.....Gear Cover Bearing Retainer
 DMIRRC-1391.....\$1.42.....Bolts for Gear Cover Bearing Retainer

DMI1390

DMI1390

DMIRRC-1001.....\$73.63....Front Seal Plate for CT-1
 DMIRRC-1001B...\$73.63....Front Seal Plate for CT-1 w/o
 2 Counterbores
 DMIRRC-1001C...\$73.63....Front Seal Plate for CT-1 w/o
 Counterbores



DMI1001

DMIRRC-1002.....\$14.67....Front Seal for CT-1 Seal Plate
 DMIRRC-1002T...\$26.46....Front Seal for CT-1 Seal Plate - Teflon Lip
 DMIRRC-1003.....\$2.95.....Seal O-Ring for CT-1 Seal Plate
 DMIRRC-1004.....\$2.95.....O-Ring for CT-1 Seal Plate Flange
 DMIRRC-1007.....\$3.70.....Spirallock for Seal Plate
 DMIRRC-1010.....\$20.57....Large Inspection Plug
 DMIRRC-1015.....\$1.42.....Large Inspection Plug O-Ring
 DMIRRC-1016.....\$13.20....Fill Level Plug
 DMIRRC-1017...\$1.42.....Fill Level Plug O-Ring
 DMIRRC-1034.....\$20.57....Breather Assembly

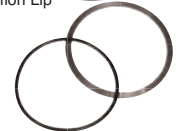

DMI1007
DMI1003



DMI1002

DMIRRC1002T

DMIRRC1010

DMIRRC-1034

Seal for DMI for SmartTube with O-Ring

DMIRRC-1003.....\$30.59



Hollow 31 Spline Axle

DMIRRC-2300-25.5.....\$154.72.....25.5"
 DMIRRC-2300-28.5.....\$154.72.....28.25"
 DMIRRC-2300-29.75.....\$154.72.....29.75"
 DMIRRC-2300-32.5.....\$154.72.....32.5"
 DMIRRC-2300-33.5.....\$154.72.....33.5"
 DMIRRC-2300-35.5.....\$154.72.....35.5"
 DMIRRC-2300-36.5.....\$154.72.....36.5"
 DMIRRC-2300-38.5.....\$154.72.....38.5"



Solid 31 Spline Axle

DMIRRC-2350-25.5.....\$122.25.....25.5"
 DMIRRC-2350-28.5.....\$122.25.....28.5"
 DMIRRC-2350-29.75.....\$122.25.....29.75"
 DMIRRC-2350-30.5.....\$122.25.....30.5"
 DMIRRC-2350-31.....\$122.25.....31"
 DMIRRC-2350-31.5.....\$122.25.....31.5"
 DMIRRC-2350-32.5.....\$122.25.....32.5"
 DMIRRC-2350-33.5.....\$122.25.....33.5"
 DMIRRC-2350-35.....\$122.25.....35"
 DMIRRC-2350-35.5.....\$122.25.....35.5"
 DMIRRC-2350-36.....\$122.25.....36"
 DMIRRC-2350-36.5.....\$122.25.....36.5"
 DMIRRC-2350-38.....\$122.25.....38"



Ring and Pinion

DMIRRC-1300.....\$397.31...4.12 R & P
 DMIRRC-1300-02.....\$577.07...4.12 R & P - EDM
 DMIRRC-1300-02-05...\$706.50...4.12 R & P - EDM / Polish
 DMIRRC-1300-05.....\$526.74...4.12 R & P - Polish
 DMIRRC-1305.....\$397.31...4.86 R & P
 DMIRRC-1305-02.....\$577.07...4.86 R & P - EDM
 DMIRRC-1305-02-05...\$706.50...4.86 R & P - EDM / Polish
 DMIRRC-1305-05.....\$526.74...4.86 R & P - Polish



DMIRRC-1306.....\$176.82...Bearing & Posi Lock Kit

Northeast Modified Chevy/Ford Bellhousings



Chevy/Ford NE Modified

No Flywheel and Coupler
Aluminum..BER300-NFC..\$419.95
Magnesium..BER300-NFC-MAG..\$550.65

Late Model Chevy Bellhousings

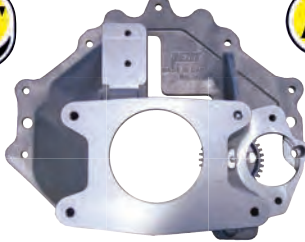

Chevy Late Model

No Flywheel and Coupler
Aluminum..BER301-NFC..\$435.00
Magnesium..BER301-NFC-MAG..\$559.00

Late Model Ford Bellhousings

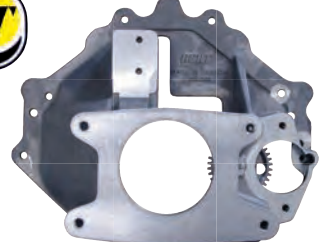

Ford Late Model

No Flywheel and Coupler
Aluminum..BER301F-NFC..\$470.17
Magnesium..BER301F-NFC-MAG..\$583.25

Note: Please call for other Make & Model Bellhousings.

Two Piece Flywheels & Couplers



BER007



BER007A

Drive Flange Modified

ChevyBER007.....\$82.40
Chevy Aluminum.....BER007-A.....\$84.48
New Chevy 3 Inches.....BER007-NC.....\$84.48
LS1 Chevy.....BER007-LS1.....\$84.48
Dodge 340/360.....BER007-D.....\$84.48
Ford 302/351.....BER007-F.....\$84.48
Ford 429/460.....BER007-F429.....\$84.48



BER371-H



BER371-L-G

Drive Flange Late Model - Chevy

Steel Gilmer Hub.....BER371-G.....\$90.97
Steel HTD Hub.....BER371-H.....\$90.97
Aluminum Gilmer Hub.....BER371-L-G.....\$105.58
Aluminum HTD Hub.....BER371-L-H.....\$105.58

Two-Piece Flywheel

Flywheel Ring Chevy.....BER370.....\$62.50
Flywheel Ring Offset .080 more..BER370-M..\$62.50
Uses less shims.

Bert Flywheel Bolts

6 pcs 12 pt 1-1/4" x 7/16-20

BSC80625.....\$12.00

6 pcs 12 pt 1" x 7/16-20 NEW

BSC80624.....\$12.00

1" works w/most 1 Pc Flywheels.

Chevy Flywheel Shim

BER324-NC.....\$1.27



One Piece Flywheels



1 Piece Modified Flywheel

Dodge Modified.....BER311-D.....\$114.17
Dodge 360 Ext. Bal.....BER311-D360-EXT.B..\$156.86
Dodge Hemi.....BER311-DH.....\$114.17
Ford 429/460 Modified...BER311-F429.....\$114.17
Modified LS1.....BER311-LS1.....\$114.17
New Chevy 3".....BER311-NC.....\$114.17
New Chevy 3" Ext Bal.....BER311-NC-EXT.....\$151.35
Oldsmobile Modified.....BER311-O.....\$114.17
Pontiac Modified.....BER311-P.....\$114.17
Pontiac 2000 Modified....BER311-P2000.....\$114.17
Pinto 1600 & 2000 Mod..BER311-PIN.....\$114.17
Pinto 2300.....BER311-PIN2300.....\$114.17
Flywheel Modified 454....BER312.....\$156.86

BER318-400
Gilmore
(Square Tooth)



1 Piece Late Model Gilmore Flywheel

400 SB Ext Bal Gilmore..BER318-400.....\$193.46
Belt Guide Washer.....BER318-BG.....\$3.42
Dodge Gilmore.....BER318-D.....\$147.28
Dodge R5 Gilmore.....BER318-D-R5.....\$147.27
Dodge Hemi Gilmore....BER318-DH.....\$147.28
Ford R5 Gilmore.....BER318-F-R5.....\$147.27
Ford 429/460 Gilmore...BER318-F429.....\$147.28
New Chevy 3" Gilmore...BER318-NC.....\$147.28
Oldsmobile Gilmore.....BER318-O.....\$147.28
Pontiac Gilmore.....BER318-P.....\$147.28
Pontiac 2000 Gilmore....BER318-P2000.....\$147.28
Pinto Gilmore.....BER318-PIN.....\$147.28
Pinto 2300 Gilmore.....BER318-PIN2300.....\$147.28

BER320-SL3
HTD
(Round Tooth)



1 Pc Late Model HTD Flywheel

HTD Ext. Bal. for 400C...BER320-400.....\$193.46
Dodge HTD.....BER320-D.....\$147.28
Dodge R5 HTD.....BER320-D-R5.....\$147.27
Dodge Hemi HTD.....BER320-DH.....\$147.28
Ford 429/460 HTD.....BER320-F429.....\$147.28
HTD LS1.....BER320-LS1.....\$147.28
New Chevy 3" HTD.....BER320-NC.....\$147.28
New Chevy 3" Ext. Bal...BER320-NC-EXT.....\$185.99

CRATE

Oldsmobile HTD.....BER320-O.....\$147.28
Pontiac HTD.....BER320-P.....\$147.28
Pontiac 2000 HTD.....BER320-P2000.....\$147.28
Pinto 1600 & 2000 HTD..BER320-PIN.....\$147.28
Pinto 2300 HTD.....BER320-PIN2300.....\$147.28
LS3.....BER320-LS3.....\$147.28

Ford Flywheel Adapters



BER370-F



Ford Flywheel Adapter

Ford Flywheel Ring
BER370-F.....\$109.99

Bellhousing Pieces

Idler Gear

BER303.....\$145.98

Idler Gear Bushing

BER304.....\$7.28

Idler Gear Shaft

BER306.....\$13.46

Bellhousing Plate Modified

BER307-M.....\$26.87



Bellhousing Plate Late Model

BER307.....\$26.88

Idler Gear Spring

BER308.....\$5.77

Idler Gear Washer

BER309.....\$1.66

Idler Gear Shaft Grease Fitting

BER310.....\$1.61



Starters



Inboard Starters

Late Model and Modified Starters

Inboard mount for use on Bert style bellhousings on either Northeast Modifieds or Late Models.

Northeast Modified.....BER323M2KW..\$229.90

Late Model.....BER323L2KW...\$229.90



Late Model 1.4kw Bert Starter

BSC20020.....\$195.75



Modified 1.4kw Bert Starter

BSC20021.....\$195.75



Dirt Modified Transmission 2nd Generation

BER1200...\$1815.00(Shifter NOT Included)



Optional Remote Side Shifter Kit

For BER1200 Transmission

Now you can shift your race car just as easy as shifting a street car. Bert has designed a remote shifter for the east coast modified second generation trans (SG-1200), because of the single shifting rod design the use of a heavy duty cable and adapter bracket has create a great system. This shifter is handy and brings comfort to driver specially when going in and out of the cockpit. BER078-SG...\$239.95

2nd Generation Transmission



Regular Shifter Kit

For BER1200 Transmission
BER078-S...\$79.95



Late Model Trans 2nd Generation

BER1300.....\$1799.99

Late Model Trans 2nd Generation Muncie Length

BER1400.....\$1799.99

Late Model Trans Ball Spline 2nd Generation

BER1500....\$2399.00

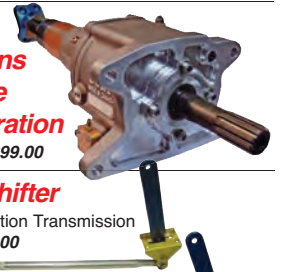

Regular Shifter

For 2nd Generation Transmission
BER1310...\$79.00

Bloomquist Shifter

For 2nd Generation Transmission
BER1311...\$79.00



We Rebuild All Bert Transmissions in house!

1st Generation: The Original Transmission



Dirt Modified Trans Original Style

Open Drive TransBERMOZ.....\$1789.53
Closed Drive Trans.....BERMCZ.....\$1889.13

Shown with
optional shifter

Dirt Late Model Transmission

It feature an internal clutch assembly for reduced rotating weight, and new "dog teeth" gears. Trans available with optional coupler and shifter for an additional amount per item. Bellhousing includes Gilmer or HTD flywheel.
Late Model Trans Alum ..BERLMZ.....\$1599.00



Complete

Late Model Trans w/Ball Spline

Reduces drivetrain bind. Available in aluminum or mag. Order the coupler of your choice separately.
BERLMZ-BS\$2369.73



Tailshaft only upgrade your late model transmission

BER003-BS\$1122.34
BER003-BS-MAG\$1176.79

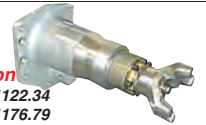

Replacement Parts

Modified Basic Kit..BER090..\$105.29

- (6) Radius Tooth Clutch Disk.....BER026
- (1) Front Oil Seal.....BER029
- (1) Rear Oil Seal.....BER052
- (2) Shifter Seal.....BER049
- (1) O-ring.....BER015
- (2) Fork Retaining Pin.....BER071
- (2) Frost Plug 3/4" Cup.....BER076

Modified Full Rebuild Kit..BER092..\$301.12

- (6) Radius Tooth Clutch Disk.....BER026
- (1) Front Oil Seal.....BER029
- (1) Rear Oil Seal.....BER052
- (2) Shifter Seal.....BER049
- (1) O-ring.....BER015
- (2) Fork Retaining Pin.....BER071
- (2) Frost Plug 3/4" Cup.....BER076
- (1) Front Input Bearing.....BER032
- (1) Output Bearing (modified).....BER051
- (2) Radial Needle Roller.....BER020
- (2) Cage Needle Bearing.....BER045
- (2) Cage Needle Bearing.....BER074
- (3) Thrust Needle Roller.....BER018
- (2) Thrust Washer 90.....BER019.090
- (4) Thrust Washer 60.....BER019.060
- (1) Thrust Washer 30.....BER019.030

Piston Kit with O-Ring

Replaces BER061 and BER062.
BER61-K...\$10.93



Spectro Race Bert Transmission Fluid

We highly recommend this stuff for use in BERT transmissions because of the internal clutch.

1 Quart..SPECRACETF..\$9.80



Replacement Modified Shifter Kit

The first thing to go when you lose a driveshaft is your shift linkage. Replace the whole thing with this complete kit.

Does **Not** include rod ends.
BER078-M.....\$120.68



Bert and Winters Hand Clutch Master

ENG18875...\$99.50

Rebuild Kit

ENG151EP...\$14.95

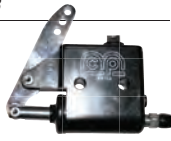

New Style Clutch Handle

BER066-1C.....\$17.40

Bert Clutch Handle Knob

BER078-C.....\$15.95



Bert Transmission Gaskets

- Front Cover/Main Case Gasket .015 Thick
BSCBER001\$3.50
- Bert Side Cover Gasket .030 Thick
BSCBER002\$3.75
- Bert Rear Cover Gasket .030 Thick
BSCBER003\$3.95

Note: All transmission rebuild parts available.

Late Model Basic Kit..BER091..\$108.88

- (6) Radius Tooth Clutch Disk.....BER026
- (1) Front Oil Seal.....BER029
- (1) Late Model Rear Oil Seal.....BER065
- (1) Extension Bushing.....BER060
- (2) Shifter Seal.....BER049
- (1) O-ring.....BER015
- (2) Fork Retaining Pin.....BER071
- (2) Frost Plug 3/4" Cup.....BER076

Late Model Full Rebuild Kit..BER093..\$268.07

- (6) Radius Tooth Clutch Disk.....BER026
- (1) Front Oil Seal.....BER029
- (1) Late Model Rear Oil Seal.....BER065
- (1) Extension Bushing.....BER060
- (2) Shifter Seal.....BER049
- (1) O-ring.....BER015
- (2) Fork Retaining Pin.....BER071
- (2) Frost Plug 3/4" Cup.....BER076
- (1) Front Input Bearing.....BER032
- (1) Output Bearing (L/M).....BER056
- (2) Radial Needle Roller.....BER020
- (2) Cage Needle Bearing.....BER045
- (2) Cage Needle Bearing.....BER074
- (3) Thrust Needle Roller.....BER018
- (2) Thrust Washer 90.....BER019.090
- (4) Thrust Washer 60.....BER019.060
- (1) Thrust Washer 30.....BER019.030

Piston Kit with O-Ring

Replaces BER061 and BER062.
BER61-K...\$10.93

Common New Style fits all 1st Gen Trans. Replacement Parts

- Radius Tooth Clutch Disk.....BER026.....\$10.20
- Steel Clutch.....BER027.....\$4.75
- Input Modified Dog Teeth.....BER008-Z.....\$169.41
- Input Late Model Dog Teeth.....BER009Z.....\$191.92
- Direct Slider Dog Teeth.....BER011Z.....\$138.10
- Reverse Idler Gear.....BER044.....\$43.40
- Shifter Fork.....BER041.....\$49.15
- Reverse Fork.....BER075.....\$39.10



2nd Generation Transmission Rebuild Parts

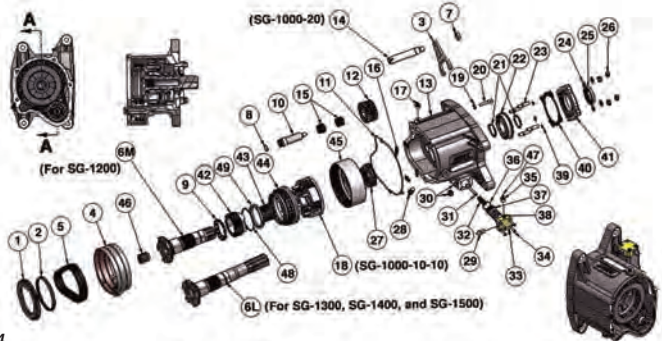

Item Description (Quantity)	Part #	Price
1.) Reverse Gear (1)	BERSG-1029	\$108.94
2.) Reverse Bearing - Seal Together w/SG-1061 (1)	BERSG-1031-K	\$45.55
3.) Selector Fork (1)	BERSG-1017	\$14.20
4.) Bert Band - Together w/SG-1030-01 (1)	BERSG-1030-02	Scall
5.) Double Raw Chain (1)	BERSG-1076	\$46.80
6M.) Input Shaft (For SG-1200) (1)	BERSG-1002	\$369.28
6L.) Input Shaft Late (For SG-1300, SG-1400, & SG-1500) (1)	BERSG-1003	\$432.00
7.) Hex Nylon Lock 1/2-20 UNF (1)	BERSG-1056	\$0.48
8.) O-Ring OD 3/4 ID 5/8 with 1/16 (1)	BERSG-1079	\$0.16
9.) Carrier Truste Support Bearing (1)	BERSG-1032-K	\$52.67
9b.) Steel Ball 5/16 (1)	BERSG-1060	Scall
10.) Reverse Gear Shaft (1)	BERSG-1027	\$39.92
Sell Together w/SG-1034	BERSG-1027	\$39.92
11.) Case Gasket (1)	BERSG-1001-G	\$2.89
12.) Reverse Idler Gear (1)	BERSG-1028	\$142.53
13.) Main Casting (1)	BERSG-1001	\$640.29
14.) Front Fork System Sub Assembly (1)	BERSG-1000-20	\$66.95
15.) Needle Bearing 20 x 24 x 17 (2)	BERSG-1057	\$4.73
16.) Trust Washer (4)	BERSG-1021	\$0.50
17.) Breather (1)	BERSG-1068	\$4.33
18.) Carrier Sub Assembly (1)	BERSG-1000-10-10	\$292.49
19.) O-Ring OD 9/16 Wall 1/16 (1)	BERSG-1054	\$0.05
20.) Front Fork Support Screw (1)	BERSG-1022	\$8.22
21.) External Retaining Rings, 5160-137 (2)	BERSG-1080	\$2.04
22.) Input Shaft Bearing (1)	BERSG-1053	\$30.31
23.) Front Cover Stud (4)	BERSG-1037	\$8.43
24.) Flat Washer 5/16 (4)	BERSG-1156	\$0.05

25.) Shaft Seal CRWA1-R (1)	BERSG-1052	\$6.93
26.) Hex Nylon Lock 5/16-24 UNF (4)	BERSG-1258	\$0.20
27.) Sun Gear Selector (1)	BERSG-1006	\$124.54
28.) Band Anchor Stud (1)	BERSG-1033	\$9.92
29.) Servo AN Adapter (1)	BERSG-1064	\$1.79
30.) Magnetic Drain Plug 1/4 NPT (2)	BERSG-1063	\$2.49
31.) Band Anchor Shaft (1)	BERSG-1019	\$8.72
32.) Piston Return Spring (1) OD 5/8 x 1-1/4 x w (.069 x .109)	BERSG-1078	\$5.39
33.) Servo Cover (1)	BERSG-1020	\$36.13
34.) Flat Head 82 Degree #10-24 UNC x .750 (4)	BERSG-1066	\$0.12
35.) Servo Bleed Adapter (1)	BERSG-1065	\$6.65
Sell Together w/SG-1067	BERSG-1065	\$6.65
36.) O-Ring 1/16 x 1.000 (A.P.D.N.) (1)	BERSG-1081	\$0.16
37.) Servo Piston (1)	BERSG-1018	\$12.37
38.) O-Ring 3/32 (2)	BERSG-1077	\$1.35
39.) Stud O-Ring (4)	BERSG-1082	\$0.11
40.) Gasket (1)	BERSG-1039	\$3.99
41.) Front Cover (1)	BERSG-1004	\$47.34
42.) Sun Gear (1)	BERSG-1012	\$123.25
43.) Needle Bearing 40 x 45 x 27 (1)	BERSG-1069	\$11.66
44.) L and R Carrier (1)	BERSG-1009	\$238.62
45.) Carrier Crown (1)	BERSG-1007	\$171.98
46.) Needle Bearing WJ 12 x 16 x 16 (1)	BERSG-1058	\$4.73
47.) Servo Bleed Adapter Plug (1)	BERSG-1067	\$6.65
48.) Sun Gear Trust Ring (1)	BERSG-1016	\$4.98
49.) Carrier Support (1)	BERSG-1011	\$1.19

2nd Generation Dirt Modified Transmission Rebuild Parts

Item Description (Quantity)	Part #	Price
1.) Shaft Seal (1)	BERSG-1150	\$1.79
2.) Shifting Rod (1)	BERSG-1102	\$28.25
3.) Selector Fork (1)	BERSG-1017	\$14.20
4.) Set Screw 7/16 (2)	BERSG-1157	\$4.23
5.) Hex Nylock 1/2-20 UNF (1)	BERSG-1056	\$0.48
6.) Hex Nylock 5/16-18 UNC x 1.500 (4)	BERSG-1155	\$0.45
7.) Hex Nylock 5/16-18 UNC x 2.000 (1)	BERSG-1154	\$0.70
8.) Lock Washer .313 (5)	BERSG-1051	\$0.05
9.) Flat Washer 5/16 (5)	BERSG-1156	\$0.05
10.) Tail Casting Modified (1)	BERSG-1201	\$259.55
11.) Plongeur Small (2)	BERSG-1035-01	\$12.05
Plongeur Big (2)	BERSG-1035-02	\$12.05
12.) Detent Spring (2)	BERSG-1158	\$1.33
13.) Output Shaft Modified (1)	BERSG-1202	\$158.38
14.) Deep Groove Ball Bearing 80mm x 40mm x 23mm (1)	BERSG-1250	\$54.82
15.) Shaft Seal CRWA1-R, Same as Bert 052 (1)	BERSG-1251	\$16.56

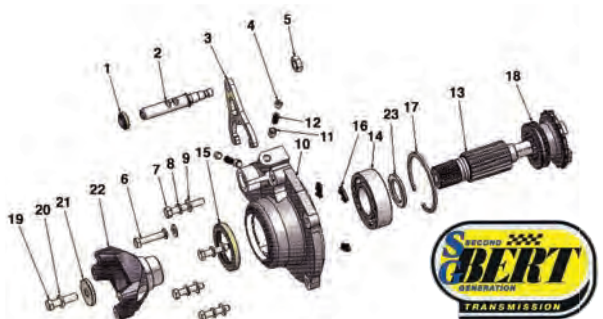

16.) Trust Washer (3)	BERSG-1021	\$0.50
17.) Internal Retaining Ring, Bore Dia 3 5/32 (1)	BERSG-1160	\$8.10
18.) Gears Selector (1)	BERSG-1101	\$195.65
19.) Hex Cap Screw 3/8-24 x 1.500 (1)	BERSG-1252	\$0.70
20.) Lock Washer 3/8 (1)	BERSG-1253	\$0.05
21.) Yoke Washer (1)	BERSG-1213	\$7.08
22.) Yoke Modified (1)	BERSG-1212	\$111.98
23.) Output Shaft Spacer (1)	BERSG-1203	\$9.22

SG-1300-01

(Tail Casting 2nd Generation)

1 Rod End 3/8-24 UNF (1)	QA1CMR6	\$2.90
2 Hex Jam Nut 3/8-24 UNC (1)	JAM006	\$0.21
3 Shaft (1)	BERSG-1150	\$1.79
4 Shifting Rod Extension (1)	BERSG-1102	\$28.25
5 Selector Fork (1)	BERSG-1017	\$14.20
6 Set Screw 3/8-16 UNC x .375 (2)	BERSG-1157	\$4.23
7 Hex Nylon Lock 1 2-20 UNF (1)	BERSG-1056	\$0.48
8 Hex Head Screw 5/16-18 UNC x 1.500 (4)	BERSG-1155	\$0.45
9 Hex Head Screw 5/16-18 UNC x 2.000 (1)	BERSG-1154	\$0.70
10 Lock Washer .313 (5)	BERSG-1051	\$0.05
11 Flat Washer 5/16 (5)	BERSG-1156	\$0.05
12 Tail Casting Late Model Sub Assy) (Sale Together) (1)	BERSG-1400-05	\$563.60
13 Plongeur Small (2)	BERSG-1035-01	\$12.05
Plongeur Big (2)	BERSG-1035-02	\$12.05
14 Spring 5/16 (2)	BERSG-1158	\$1.33
15 Output Shaft (1)	BERSG-1302	\$374.36
16 Deep Groove Ball Bearing, Snap Ring, Contact Seal on Outer Side, 60mm x 40mm x 18mm (1)	BERSG-1350	\$23.22
17 Bert Part # 031 (2)	BERSG-1083	\$1.69
18 Crown Trust Washer (3)	BERSG-1021	\$0.50
19 Internal retaining ring, Bore diameter 3 5/32 (1)	BERSG-1160	\$8.10
20 Hi Selector (1)	BERSG-1101	\$195.65



SG-1300-05 (2nd Generation Sub Assy)

1 Shaft Seal BHH1010-AD, Same as Bert Part # 065 (1)	BERSG-1354	\$15.60
2 Bert Part # 60 (1)	BERSG-1356	\$11.21
3 (1)	BERSG-1304	\$14.00
4 Hexagon Socket Button Head Cap Screw (1)	BERSG-1357	\$0.25
5 Output Tube (1)	BERSG-1303	\$60.48
6 Tail Casting (Late Model) (1)	BERSG-1301	\$431.98
7 Hexagon Socket Button Head Cap Screw (2)	BERSG-1352	\$0.75



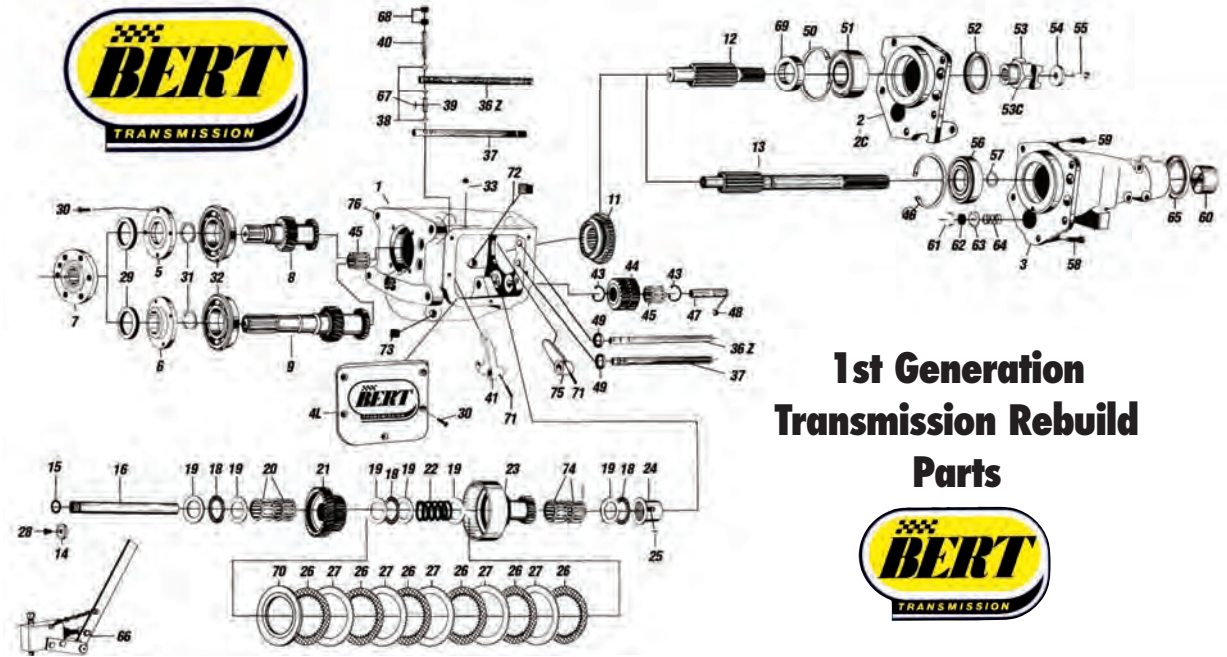

1st Generation Transmission Rebuild Parts



SG-1400-01 (Tail Casting Muncie Length)



1 Rod End 3/8-24 UNF (1)	BERSG-1151\$12.02
2 Hex Jam Nut 3/8-24 UNC (1)	BERSG-1152\$call
3 Shaft Seal (1)	BERSG-1150\$1.79
4 Shifting Rod Extension (1)	BERSG-1102\$28.25
5 Selector Fork (1)	BERSG-1017\$14.20
6 Set Screw 3/8-16 UNC x .375 (2)	BERSG-1157\$4.23
7 Hex Nylon Lock 1 2-20 UNF (1)	BERSG-1056\$0.48
8 Hex Head Screw 5/16-18 UNC x 1.500 (4)	BERSG-1155\$0.45
9 Hex Head Screw 5/16-18 UNC x 2.000 (1)	BERSG-1154\$0.70
10 Lock Washer .313 (5)	BERSG-1051\$0.05
11 Flat Washer 5/16 (5)	BERSG-1156\$0.05
12 Tail Casting Late Model Sub Assembly (Sale Together) (1)	BERSG-1400-05\$563.60
13 Plongeur Small (2)	BERSG-1035-01\$12.05
Plongeur Big (2)	BERSG-1035-02\$12.05
14 Spring 5/16 (2)	BERSG-1158\$1.33
15 Output Shaft (1)	BERSG-1402\$358.97
16 Deep Groove Ball Bearing, Snap Ring, Contact Seal on Outer Side, 60mm x 40mm x 18mm (1)	BERSG-1350\$23.22
17 Bert Part # 031 (2)	BERSG-1083\$1.69
18 Crown Trust Washer (3)	BERSG-1021\$0.50
19 Internal retaining ring, Bore diameter 3 5/32 (1)	BERSG-1160\$8.10
20 Hi Selector (1)	BERSG-1101\$195.65

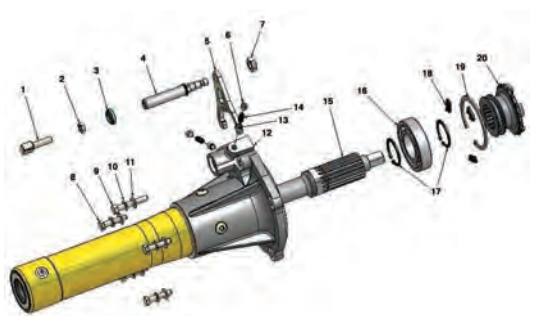

SG-1400-05 (Muncie Length Sub Assembly)

1 Shaft Seal BHH1010-AD, Same as BER 065 (1)	BERSG-1354\$15.60
2 Bert Part # 60 (1)	BERSG-1356\$11.21
3 Tube Bushing (1)	BERSG-1304\$14.00
4 Hexagon Socket Button Head Cap Screw (1)	BERSG-1357\$0.25
5 Output Tube (1)	BERSG-1403\$99.97
6 Tail Casting (Late Model) (1)	BERSG-1301\$431.98
7 Hexagon Socket Button Head Cap Screw (2)	BERSG-1352\$0.75

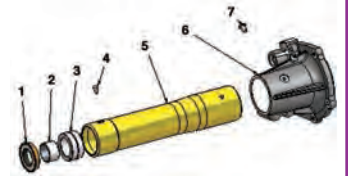

SG-1500-01 (Tail Casting Late Model Ball Spine Assembly)

1 Rod End 3/8-24 UNF (1)	BERSG-1151\$12.02
2 Hex Jam Nut 3/8-24 UNC (1)	BERSG-1152\$call
3 Shaft Seal (1)	BERSG-1150\$1.79
4 Shifting Rod Extension (1)	BERSG-1102\$28.25
5 Selector Fork (1)	BERSG-1017\$14.20
6 Set Screw 3/8-16 UNC x .375 (2)	BERSG-1157\$4.23
7 Hex Nylon Lock 1 2-20 UNF (1)	BERSG-1056\$0.48
8 Output Shaft (4)	BERSG-1502\$317.86
9 Bert Part # 031 (1)	BERSG-1053\$30.31
10 Hex Head Screw 5/16-18 UNC x 1.500 (4)	BERSG-1155\$0.45
11 Hex Head Screw 5/16-18 UNC x 2.000 (1)	BERSG-1154\$0.70
12 Lock Washer .313 (5)	BERSG-1051\$0.05
13 Flat Washer 5/16 (5)	BERSG-1156\$0.05
14 Tail Casting Late Model Sub Assembly (Sale Together) (1)	BERSG-1500-05\$542.05
15 Plongeur Small (2)	BERSG-1035-01\$12.05
Plongeur Big (2)	BERSG-1035-02\$12.05
16 Spring 5/16 (2)	BERSG-1158\$1.33
17 Deep Groove Ball Bearing, Snap Ring, Contact Seal on Outer Side, 60mm x 40mm x 18mm (1)	BERSG-1350\$23.22
18 Crown Trust Washer (3)	BERSG-1021\$0.50
19 Internal retaining ring, Bore diameter 3 5/32 (1)	BERSG-1160\$8.10
20 Hi Selector (1)	BERSG-1101\$195.65

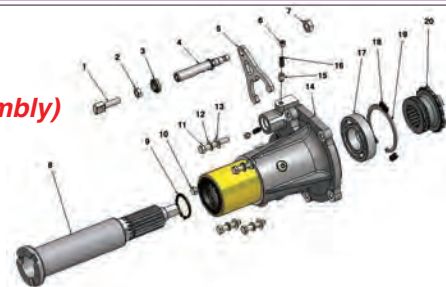

SG-1500-05 (Tail Casting Late Model Ball Spine Sub Assembly)

1 Hexagon Socket Button Head Cap Screw (2)	BERSG-1352\$0.75
2 Tail Casting (Late Model) (1)	BERSG-1301\$431.98
3 (1)	BERSG-1503\$45.10
4 Needle Bearing HJ324120 (1)	BERSG-1504\$30.84
5 Snap Ring (1)	BERSG-1505\$4.98
6 CR Seal 19762 (1)	BERSG-1506\$9.42

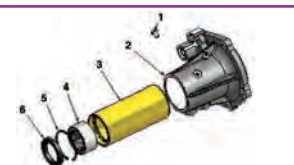

Strange Oval

Slip Yokes

Forged Driveshaft 32 Spline 1310
STRDYM235.....\$169.95

Billet DS 32 Spline 1310 for Bert Trans
STRDYM205.....\$127.95

Billet U-Joint Strap Kit 1310 for Bert Trans Yoke

STRDYM205-1.....\$70.95

Slip Yoke Spring

STRDYMSPRING.....\$2.80

Billet Quick Change Yoke

STRDYM225.....\$127.34

19-3/8" 32 Spline Driveshaft

STRDM103-19-3/8.....\$201.50

Hollow Steel Driveshaft

32-32 Spline - 20
DMISRC-2467-32.....\$212.70

U-Joint Yoke Long

Steel Billet U-Joint Yoke - Long 32 Spline
DMISRC-2342-32.....\$191.30

Neapco U-Joints

1310 1-1/16 x 3 1/4.....NEA1-0153.....\$12.52
1310 9/16" hole in center...NEA1-0153X-SP.....\$20.67

Spicer U-Joints 1310 1-1/16 x 3 1/4

Greaseable.....SPI5-53X.....\$13.95
Non-Greaseable.....SPI5-1310X.....\$18.95

U-Bolts (Pair)

U-Bolts (pair).....BSC5855.....\$6.24

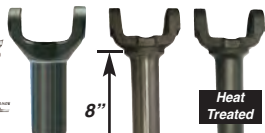

Slip Yoke FAS6133

5.5" Yoke 16 Spline
FAS6133.....\$30.95
8" Bert Late Model Slip Yoke 27 Spline
FASXLT-8.....\$46.95
8" Winters Late Model Slip Yoke
Heat Treated
FASXLT-8HD.....\$65.25
8" Bert Wide Angle Slip Yoke 27 Spline
FASXLT-8WA.....\$91.95



Drive Shafts

19" LW Driveshaft Length 22.5 CTC
FAS2-083M-DM-19.....\$297.25
20" LW Tubular Driveshaft Std Length 22.5 CTC
FAS2-083M-DM-20.....\$287.95

Billet U-Bolt Kits

FASBBSK...\$48.50



Ball Spline Driveshafts

19" (Troyer) ...BER240-19.....\$775.56
23" (TEO) ...BER240-23.....\$775.56

Driveshafts

Gun drilled and internally polished for light-weight & added strength. Fully floating at both ends allows freer suspension movement. Small diameter takes up less room.

16 x 16 Spline for open drive.

Overall Length

14".....BER250.....\$151.34
16".....BER251.....\$151.34
18".....BER252.....\$147.62
20".....BER253.....\$147.62
22".....BER254.....\$151.34
24".....BER255.....\$151.34
26".....BER256.....\$151.34
28".....BER257.....\$151.34
30".....BER258.....\$151.34

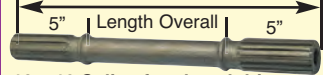

16 x 10 Spline for closed drive.

Overall Length

14".....BER259.....\$151.34
16".....BER260.....\$151.34
18".....BER261.....\$151.34
20".....BER262.....\$151.34
22".....BER263.....\$151.34
24".....BER264.....\$151.34

Slip Yoke

High Angle Extra Clearance
PEMYSYXL8F.....\$53.20



Modified Transmission



Falcon Shorty Transmission

It features two forward speeds and a reverse with an integral hydraulic applied clutch which operates low and reverse gears. High gear is a 1 to 1 direct drive ratio, while low gear is a 2.4 to 1 ratio, the Falcon was designed with durability as a requirement, with internal clutches being the only degrading internal parts. Two types of input drives are available. Conventional 18 splines on the main drive that engages splines in the crank coupler is standard. It measures 9 7/8" from front of case to center of rear yoke, and comes complete with a crank coupler, lightweight shifter and hand operates master cylinder. The Falcon Shorty is only available in open drive.
WIN60150.....\$1344.00



Falcon Shorty

Basic Rebuild Kits.....WIN62824-2.....\$120.73
Complete Rebuild Kits.....WIN62825-2.....\$224.35

Late Model Transmission

Falcon Late Model Transmission

It weighs in at 43 pounds with an aluminum case and extension housing and an even lighter 38 pounds 2 ounces in magnesium.
WIN60100.....\$1343.75



Falcon Late Model Rebuild Kit

Basic Rebuild Kits.....WIN62822-2.....\$95.90
Complete Rebuild Kits.....WIN62823-2.....\$199.79

Modified Bellhousings



2 5/8" Deep Flywheel Housing Assy

With reverse starter mt. Accepts popular internal clutch transmissions with short input shafts including the Falcon Trans. Mounts included for small block and big block camshaft driven pumps. Includes idler gear, starter ring gear and spacer shims.
Chevy.....WIN62844.....\$375.00
Ford.....WIN62904.....\$542.15

Shifter Kit Modified

WIN60115-S...\$140.05

Late Model Bellhousings



6 1/4" Deep Flywheel Housing Assy

Chevy Aluminum.....WIN62843.....\$409.57
Chevy Magnesium.....WIN62843M.....\$512.49
Ford Magnesium.....WIN62843M-2.....\$525.49

Starters

3.73:1 Gear Reduction, 2.4 kw
Reverse Mt, 6-1/2 in Ring Gear
Shorty Starter.....WIN62910.....\$238.00
Late Model Starter.....WIN62911.....\$248.40



Flywheels & Couplers

Starter Ring Gear & Shims

Application.....Starter Ring Gear.....Shim
SBC & BBC.....WIN62479-A.....\$2.70
SBC.....WIN62479-C.....\$2.70
Late SBC.....WIN62479-D.....\$2.80

Flywheel for Crate Motor CRATE

Flywheel, Late Chevy, Ext Balance, 18 Spline
WIN63844-18.....\$133.65

Flywheel Shim
WIN62321.....\$2.80

Crank Couplers Short

WIN62348-18...SBC & BBC 18 Spline.....\$63.36
WIN62349-18...SBC & BBC 18 Spline, Alum.....\$70.95
WIN62349-18...SBF 18 Spline.....\$70.11
WIN62349-18A.SBF 18 Spline, Alum.....\$91.80
WIN62350-18...Late SBC 18 Spline.....\$72.70
WIN62350-18A.Late SBC 18 Spline, Alum.....\$70.11

Crank Couplers w/HTD

Chevy 18 Spline
w/HTD Pulley.....WIN62446.....\$101.35
w/HTD Pulley, Alum.....WIN62446A.....\$112.57
Ford 18 Spline
w/HTD Pulley.....WIN62887.....\$101.35
w/HTD Pulley, Alum.....WIN62887A.....\$112.57
Chevy Late 18 Spline
w/HTD Pulley.....WIN62890.....\$99.14
w/HTD, Alum.....WIN62890A.....\$112.57

Shifter

The shifters feature a lightweight aluminum dual handle designed for rough tracks. Levers can be locked in with simple detent so it can't jump out of gear. Bert shifter with rods, clevis kit & mounting plate. (BK or R)
KLUKRC-7400R...\$132.80

CIRCLE TRACK CLUTCHES

Stock Clutch Rule Systems

The 10.5" diaphragm for GM or Ford applications features a billet aluminum pressure ring with steel face to provide a durable mating surface for the clutch disc. When used with a 6 point RAMetallic disc, the clutch weighs just over 15 pounds. If a full face disc is required, the RAM 200 series organic disc will provide great holding power. RAM also offers several lightweight billet steel flywheels to match these components. If all steel components are required for the clutch system, RAM makes a similar diaphragm plate with a steel ring. All street stock components are factory rebuildable.



Complete System	
Chevy pre-86 10.5" 10 spline 25.5 lbs.	RAM900100 \$760.00
Chevy pre-86 10.5" 10 spline 23.5 lbs.	RAM910100 \$775.00
Chevy 86-up 10.5" 10 spline 25.5 lbs.	RAM900300 \$760.00
Chevy 86-up 10.5" 10 spline 23.5 lbs.	RAM910300 \$775.00

Pressure Plates	
GM steel lw diaphragm pressure plate, 11.7 lbs.	RAM851 \$375.00
GM lw diaphragm pressure plate, 13.5 lbs.	RAM801 \$317.87
GM std weight diaphragm plate, 18.5 lbs.	RAM401 \$185.00
Ford lw diaphragm pressure plate, 13 lbs.	RAM834 \$344.00
Ford std weight diaphragm plate, 18 lbs.	RAM434 \$196.00
Ford 2000/2300 steel ring pressure pl 8.5" 10 lbs.	RAM40315 \$123.26

Clutch Discs	
GM 10.5 x 1 1/8-10 6 point solid hub disc, 2.5 lbs.	RAM1021 \$189.00
GM 10.5 x 1 1/8-26 6 point solid hub disc, 2.5 lbs.	RAM1029 \$189.00
Ford 10.5 x 1 1/16-10 6 pt solid hub disc, 2.5 lbs.	RAM1025 \$189.00
GM 10.5 x 1 1/8-10 solid hub organic disc, 2 lbs.	RAM251 \$103.00
GM 10.5 x 1 1/8-26 solid hub organic disc, 2 lbs.	RAM259 \$103.00
Ford 10.5 x 1 1/16-10 solid hub organic disc, 2 lbs	RAM255 \$103.00

Flywheels	
Chevy lw steel flywheel pre-86 '0' bal 15 lb.	RAM1510 \$269.00
Chevy lw steel flywheel pre-86 '0' bal 11.7 lb.	RAM1510-12 \$272.00
Chevy lw steel flywheel pre-86 '0' bal 9.7 lb.	RAM1510-10 \$274.00
Chevy lw steel flywheel 86-up 'ext' bal. 15 lb.	RAM1512 \$269.00
Chevy lw steel flywheel 86-up 'ext' bal. 11.7 lb.	RAM1512-12 \$272.00
Chevy lw steel flywheel 86-up 'ext' bal. 9.7 lb.	RAM1512-10 \$274.00
Chevy lw steel flywheel 86-up '0' bal. 15 lb.	RAM1514 \$269.00
Ford 2000/2300 lw steel flywheel 9.5 lbs. 15 lb.	RAM1535 \$263.00

Street Hydraulic Release Bearings

They are perfect for custom builds, kit cars, or other applications where the standard release mechanism may not fit. Bearings feature .700 inch travel, and are designed to work with up to a 3/4 inch master cylinder. Kits include the release bearing, bleed kit, and mounting hardware.



GM for Muncie, Saginaw, T-10 1.375" collar dia.	RAM78125 \$135.00
Ford T-5 transmission 1.435" collar	RAM78130 \$239.00
Ford Tremec transmission 1.435" collar	RAM78132 \$249.00

REPLACEMENT PARTS	
O-ring set	RAM78505 \$9.77
Remote bleeder kit	RAM78510 \$24.70
Replacement bearing only	RAM78015 \$33.24

A...14.14
B...0.450
C...0.170
D...2.49

SFI Spec 29.1 True Billet Flexplates
Our line of True Billet flexplates is second to none. No other manufacturer can claim to have stronger gear teeth, less runout or more consistent quality. They are now available for a wide variety of domestic engine and transmission applications. We also offer manufacturing of special flexplates, which are made to your specifications, and hardware to complete the installation well.

Total Weight.....	6.3 lbs.
Counter Bal Wt.....	Neutral
Converter Pat.....	3 on 10.75 and 3 on 11.5
Tooth Count 168 • Pitch 12.....	MEZFP300 \$397.71
Tooth Count 139 • Pitch 10.....	MEZFPT300 \$397.71
Bolt Kit.....	MEZFP437625 \$17.75



7.25 Multi-Disc Systems

The RAM 7.25 series clutch system utilizes our extensive knowledge to provide a more durable 7 1/4 inch clutch system. A new internal drive mechanism provides smooth driveable engagement. The four pad disc design has twice the friction material of other 7 1/4 inch clutches and is our own proprietary mix known for its outstanding durability. The clutch discs feature 8 rivet hubs for added torque capacity. Works with mechanical or RAM hydraulic release bearings shown below.



Chevy pre-86 3 disc	1 1/8-10	12.8	RAM8351 \$669.00
Chevy pre-86 3 disc	1 1/8-26	12.8	RAM8353 \$669.00
Chevy 86-up 3 disc	1 1/8-10	12.8	RAM8371 \$669.00
Chevy 86-up 3 disc	1 1/8-26	12.8	RAM8373 \$669.00
Ford SB 3 disc	1 1/16-10	12.8	RAM8355 \$669.00

7.25 Single Disc - up to 500 ft/lbs. capacity			
Chevy pre-86 1 disc	1 1/8-10	9.7	RAM8751 \$565.00
Chevy pre-86 1 disc	1 1/8-26	9.7	RAM8753 \$565.00
Chevy 86-up 1 disc	1 1/8-10	9.7	RAM8771 \$565.00
Chevy 86-up 1 disc	1 1/8-26	9.7	RAM8773 \$565.00
Ford SB 1 disc	1 1/16-10	9.7	RAM8755 \$565.00

90 Series 6 1/4" Assault Weapon Clutches

RAM Assault Weapon button style clutches are among the lightest and most affordable metallic clutches available. Each unit utilizes a CNC machined steel button flywheel and open design to eliminate heat and dirt buildup inside the unit. Patented RAMetallic friction discs stand up to occasional slippage that often puts multi-disc clutches out of commission, and the absence of internal splines eliminates the possibility of floater plate hang up. Button units are for use with a flexplate. Release bearing must be purchased separately.

Chevy pre-86 1 1/8-10 spline, 3 disc	RAM9351S \$569.00
Chevy pre-86 1 1/8-26 spline, 3 disc	RAM9353S \$569.00
Ford SB 1 1/16-10 spline, 3 disc	RAM9355S \$569.00
Chevy 86-up 1 1/8-10 spline, 3 disc	RAM9371S \$569.00
Chevy 86-up 1 1/8-26 spline, 3 disc	RAM9373S \$569.00
Chevy pre-86 1 1/8-10 spline, 2 disc	RAM9651S \$499.00

RAM Multi-Disc Hydraulic Release Bearing

RAM's new hydraulic release bearing is easier to install than the previous version and much more competitively priced. Total travel is .500" and the bearing has a rounded face for use with multi disc clutches. This bearing is not for use with stock style clutches.



Hydraulic bearing for GM	RAM78100 \$103.74
Hydraulic bearing for GM stock clutch	RAM78125 \$135.00
Remote bleeder kit	RAM78510 \$24.70
Replacement bearing (round)	RAM78010 \$33.18
Replacement bearing (flat)	RAM78015 \$33.24
Replacement 'o' ring set	RAM78500 \$16.76



SPRINT SECTION / CHASSIS



Torsion Arms

WINSRC-2688\$56.95 Torison Arm L/R
WINSRC-2689\$56.95 Torison Arm L/R L/W
WINSRC-2691\$59.95 Torison Arm



Torsion Arm Front

WINSRC-2120 ..\$36.95 Torsion Arm L/F 18-1/2"
WINSRC-2125 ..\$39.95 Torsion Arm 17"
WINSRC-2130..\$42.95 Torsion Arm R/F 16-1/2"



Pitman Arms

WINSRC-2230\$39.95 Short, 11", Lightweight
WINSRC-2240\$39.95 Long, 11" or 12" Lightweight
WINSRC-2250\$41.95 Short, 10", Broach, 11", L/W
WINSRC-2260\$39.95 Long, 10", Broach, 11" or 12", L/W
WINSRC-2270\$41.95 Short, 11", Heavy Duty
WINSRC-2280\$41.95 Long, 11" or 12", Heavy Duty
WINSRC-2290\$41.95 Short, 10", Broach, 11", HD
WINSRC-2300\$41.93 Long, 10", Broach, 11" or 12", HD

Billet Non-Wing Bird Cages

Manufactured from Certified Billet Alum material, these Non-Wing Bird Cages are machined to perfection and are truly the nicest and strongest on the market.
• Adjustable Lower Flag • Black Anodized
• Uses 28mm Bearing

Billet Non-Wing Bird Cage (Pair).....KRP-1745..\$495.00
Right Billet Non-Wing Bird Cage.....KRP-1750..\$299.00
Left Billet Non-Wing Bird Cage.....KRP-1755..\$285.00
Billet Non-Wing Bird Cage lower Flag ..KRP-1760..\$50.00



Front Axles

2-1/2" Lightweight Chrome Plated.

WINSRC1712-C-8291-J&J.....\$245.64
WINSRC1712-C-8291-MAXIM...\$315.83



Front Axles

Lightweight Front Axles are constructed using 2.5" 4130 material. All fabricated components are heli-arc welded.

2-1/2" J&J Style.....DMISRC-1900 ..\$269.77
2-3/8" Camber Split.....DMISRC-1905 ..\$269.77
2-1/2" Eagle/Maxim StyleDMISRC-1910 ..\$269.77
52" Offset Camber Split.....DMISRC-1920 ..\$269.77
53" Offset Camber Split.....DMISRC-1930 ..\$269.77

Billet Alum Straight Pitman Arms

It is designed to with stand today's toughest tracks. Machined from 2024 Alum and Precisionally Machined for optimum strength and Atomically Broached for an exact fit. 11" & 12" Adjustment Holes. Available Anodized Black. 3D Cad Designed.

SilverKRP-1400\$50.00
Anodized BlackKRP-1405.....\$55.00

Billet Alum Angle Broached Pitman Arms

It is made to get the extra offset that's needed for today's Short Steering Boxes. With the 3D Cad Deigned Lightening Pockets and sweet Radiused Edges, this Pitman Arm is strong enough to withstand the roughest tracks out there and not sacrifice driver safety or feel. Atomically Broached on an angle for a precision fit.
• 11" & 12" Adjustment Holes • Available Anodized Black
• Machined From 2024 Aluminum

SilverKRP-1410\$50.00
Anodized BlackKRP-1415.....\$55.00



Jacobs Ladder

Jacobs Ladder are available in titanium and steel.

4130 Steel w/Straps 13-5/8".....DMISRC-2505...\$71.80
4130 Steel w/Straps 14".....DMISRC-2510...\$71.80
4130 Steel w/Straps 13-1/4".....DMISRC-2515...\$71.80
Titanium w/Straps 13-1/4".....DMISRC-2525...\$202.14
Titanium w/Straps 13-5/8".....DMISRC-2530...\$202.14
Titanium w/Straps 14".....DMISRC-2540...\$202.14
Aluminum Jacobs Ladder Strap ..DMISRC-2545...\$3.66

'W' - Links WIN2515

'W'-Link 13 1/4" with straps
WINSRC2515\$46.95
'W'-Link 13 5/8" with straps
WINSRC2505\$46.13
'W'-Link 14" with straps
WINSRC2510\$46.13



Angular Contact Caged Bearings

This state-of-the-art Sprint Birdcage is designed with strength in mind but still emphasizes weight savings.
Set.....WINSRC2575...\$326.30



Birdcages

Small Double Bearing Birdcage Set
DMISRC-2575\$415.43



Aluminum Front Torsion Arms

Manufactured out of the finest American Made 2024 Alum Material & precisionally machined to perfection. These are the Strongest & Lightest Arms available.

Aluminum Short Front Torsion Arm
SilverKRP-1100\$50.00
Anodized Black.....KRP-1105\$55.00

Aluminum Long Front Torsion Arm
SilverKRP-1110\$60.00
Anodized Black.....KRP-1115\$65.00

Angle Broached Right Front Torsion Arm

Designed to let you run a softer. Right Front Torsion Bar and let the car transfer weight back over the left rear faster. The rule of the angle is that it adds 25lbs. to your Front Torsion Bar on compression. Atomically Broached. 10° Degree Angle Broached.
Silver.....KRP-1130.....\$55.00
Anodized Black.....KRP-1135.....\$60.00

"S" Style Front Torsion Arm

When you get your Car to sideways in the corner the left front tire will hit the Torsion Arm and act like a brake, thus making the car want to spin out. Well this is the fix for the problem; this "S" Style Front Torsion Arm will give you optimal clearance and help keep your Driver from spinning out. Machined from 2024 Billet Aluminum and Precisionally Machined. A Must For Non-Wing Cars. Atomically Broached.
SilverKRP-1120\$60.00
Anodized Black.....KRP-1125\$65.00

Alum. Front Torsion Arms

The Fully Radiused Design gives it the trick VMAC racing look and comes just like all VMAC racings other items either Anodized Black or just Std Silver. Both Arms and the Stop come complete with Grade 8 Hardware. Made From 2024 Billet Alum. Comes Anodized Black. Universal Kit Works On Any Car.

Sway Bar Stop

SilverKRP-1160\$35.00
Anodized Black.....KRP-1165\$40.00

Right Front Sway Bar Arm Splined

SilverKRP-1170\$60.00
Anodized Black.....KRP-1175\$65.00

Left Front Sway Bar Arm No Splines

SilverKRP-1180\$55.00
Anodized Black.....KRP-1185\$60.00

Short & Tall Adjustable Magnetic Set-Up Blocks

Machined to perfection and will work on any Std or Raised Rail Car. There are 3 Magnets installed in the bottom of each Set Up Block to keep them held into place on the Chassis Frame Rail. The Short Block Set is adj from 1 3/4" to 3" in 1/4 inch increments and also goes to 4". The Tall Block Set is adj from 3" to 5" in 1/4 inch increments and also goes to 6" for squaring the Rear End. Magnetic Base. Fully Adj. Anodized For Protection.
Short.....KRP-2585\$85.00
Tall.....KRP-2590\$95.00

Wing Tree Quick Pin Kit

This kit is designed to let you easily move your Wing up or down without using any wrenches. The two 1/4" Quick Pins are installed through the Wing Tree Slider Ends and Encapsulated with Aircraft Spiral Locking Rings. We have even included a 3/8" Quick Pin for the Wing Ram with a Spiral Lock Ring. Aircraft Grade Material. KRP-2310\$12.95

XR-1 Exploded View

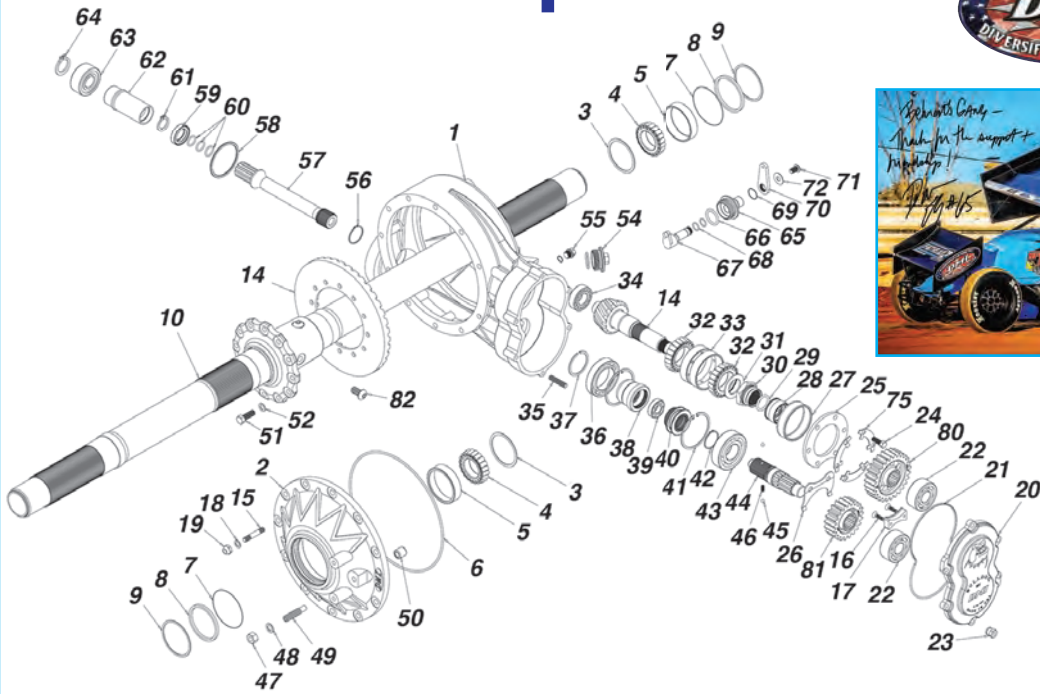

1	XR-1 Mag Rear Center Section (1)	DMIRRC-1005\$639.69	39	I.D. Shifter Bearing (1)	DMIRRC-1510\$8.78
2	XR-1 Mag Side Bell w/Brake Mt (1)	DMIRRC-1100\$269.51	40	Male Splined Shifter Coupler (1)	DMIRRC-1600\$110.49
3	Rear Axle Shim Kit 2-.075		41	Housing Bore Snap Ring (2)	DMIRRC-1520\$1.42
	3 Each - .010, .012, .015, .020 (1)		42	Stub Shaft Snap Ring (2)	DMIRRC-1620\$1.42
4	Axle Bearing (2)	DMIRRC-1229\$35.31	43	Stub Shaft Bearing (1)	DMIRRC-1625\$16.16
5	Axle Bearing Race (2)	DMIRRC-1210\$53.13	44	Lower Stub Shaft (1)	DMIRRC-1615\$94.27
6	Side Bell O'Ring (1)	DMIRRC-1215\$27.94	45	Detent Ball (2)	DMIRRC-1610\$1.42
7	Axle O'Ring (2)	DMIRRC-1105\$7.30	46	Detent Spring (1)	DMIRRC-1605\$1.86
8	Axle Seal (2)	DMIRRC-1220\$2.95	47	Back Stop Aluminum Nut (1)	DMIRRC-1150\$1.42
9	Axle Seal Spiral Lock (2)	DMIRRC-1105\$7.30	48	Back Stop Washer (1)	DMIRRC-1145\$1.42
10*	Alum Axle 1.875" I.D. Long Splines w/Spool (1)	DMIRRC-1225\$3.32	49	Back Stop Set Screw (1)	DMIRRC-1140\$6.00
14	4.12 Ring & Pinion (1)	DMIRRC-1205\$877.11	50	Ring Gear Back Stop (1)	DMIRRC-1135\$14.67
15	Side Bell Stud (9)	DMIRRC-1300\$397.31	51	Ring Gear Bolt (12)	DMIRRC-1301\$1.42
15	Short Sided Bell Stud (2)	DMIRRC-1110\$4.36	52	Ring Bolt Washer (12)	DMIRRC-1302\$1.42
16	Bolts for Gear Cover Bearing Retainer (2)	DMIRRC-1391\$1.42	54	Large Inspection Plug (1)	DMIRRC-1010\$20.57
17	Gear Cover Bearing Retainer (1)	DMIRRC-1390\$8.36	54A	Large Inspection Plug O'Ring (1)	DMIRRC-1015\$1.42
18	Side Bell Washer (11)	DMIRRC-1130\$1.42	55	Fill Level Plug (1)	DMIRRC-1016\$13.20
19	Side Bell Locknut (11)	DMIRRC-1120\$1.42	55A	Fill Level Plug O'Ring (1)	DMIRRC-1017\$1.42
20	Billet Alum Rear Cover No Bearing Gold (1)	DMIRRC-1387G\$176.82	56	Lower Shaft Snap Ring (1)	DMIRRC-1440\$1.42
21	Silicone Sealing Ring for Gear Cover (1)	DMIRRC-1345\$5.89	57	Internal 10-10 Lower Shaft (1)	DMIRRC-1430\$113.51
22	Rear Cover Bearing (2)	DMIRRC-1350\$25.04	58	Snout Bearing Spacer (1)	DMIRRC-1420\$8.78
23	Rear Cover High Nut - Black (6)	DMIRRC-1361\$7.30	59	Internal 10-10 Seal (1)	DMIRRC-1415\$14.67
24	Pinion Retainer Bolt (6)	DMIRRC-1335\$1.42	60	Lower Shaft O'Ring (3)	DMIRRC-1435\$1.42
25	Pinion Retainer Flange (1)	DMIRRC-1320\$29.41	61	10-10 Internal Snap Ring (1)	DMIRRC-1425\$1.42
26	Stub Shaft Bearing Retainer (1)	DMIRRC-1325\$29.41	62	Internal 10-10 Coupler (1)	DMIRRC-1400\$58.90
27	Pinion Bearing Spacer (1)	DMIRRC-1315\$20.57	63	Internal 10-10 Front Bearing (1)	DMIRRC-1410\$50.47
28	Posi-Lock Retainer (1)	DMIRRC-1366\$27.94	64	10-10 External Snap Ring (1)	DMIRRC-1405\$1.42
29	Posi-Lock O'Ring (1)	DMIRRC-1367\$1.42	65	Threaded Shifter Housing (1)	DMIRRC-1701\$58.90
30	Posi-Lock Nut RH	DMIRRC-1369\$35.31	66	O'Ring for Threaded Shifter Housing (1)	DMIRRC-1707\$1.42
31	Pinion Washer (1)	DMIRRC-1368\$4.36	67	Shifter Shaft (1)	DMIRRC-1710\$58.90
32	Big Pinion Bearing - Timken (2)	DMIRRC-1311\$66.42	68	Shifter Shaft O'Ring (2)	DMIRRC-1715\$1.42
33*	Big Pinion Bearing Race (1)	DMIRRC-1312\$32.35	69	Shifter Shaft Snap Ring (1)	DMIRRC-1720\$1.42
34	Small Pinion Bearing (1)	DMIRRC-1310\$32.35	70	Shifter Arm (1)	DMIRRC-1725\$14.67
35	Rear Cover Stud (6)	DMIRRC-1355\$1.42	71	Bolt for Shifter Arm (1)	DMIRRC-1730\$1.42
36	O.D. Shifter Bearing (1)	DMIRRC-1505\$23.51	72	Washer for Shifter Arm (1)	DMIRRC-1735\$1.42
37	O.D. Shifter Coupler Snap Ring (1)	DMIRRC-1515\$1.42	75	2 Bolt Locking Tab (3)	DMIRRC-1330\$4.45
38	Female Splined Shifter Coupler (1)	DMIRRC-1500\$110.49			

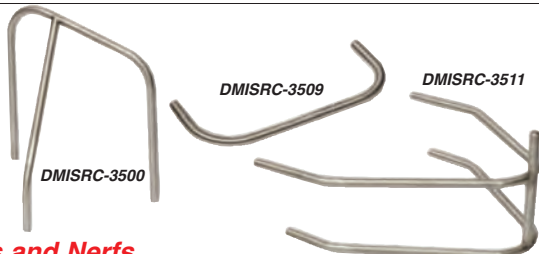

Stainless Bumpers and Nerfs

RS Shorty Nerf Bar.....DMISRC-3500 ..\$69.93	RS Hoop Nerf Bar.....DMISRC-3506 ..\$55.21
LS Shorty Nerf Bar.....DMISRC-3501 ..\$69.93	LS Hoop Nerf Bar.....DMISRC-3507 ..\$55.21
LS Shorty Nerf Bar Raised Rail...DMISRC-3502 ..\$69.93	LS Hoop Nerf Bar Raised Rail...DMISRC-3508 ..\$55.21
RS Long Nerf Bar.....DMISRC-3503 ..\$90.16	Front Bumper.....DMISRC-3509 ..\$25.77
LS Long Nerf Bar.....DMISRC-3504 ..\$90.16	Rear Bumper.....DMISRC-3511 ..\$119.60
LS Long Nerf Bar Raised RailDMISRC-3505 ..\$90.16	



SPRINT SECTION / CHASSIS



AM Series - Male Aluminum Over 10% Lighter

Right HandLeft Hand.....BoreThread
QA1AMR8-10...QA1AML8-10...0.5000...5/8-18\$12.63

Chrome Moly Steel Best for Racing

Right HandLeft Hand.....Bore.....Thread
QA1XMR8-10...QA1XML8-10 0.5000...5/8-18.....\$17.43



Forged Aluminum Direct Mt Front Hub Kit

WIN3980\$240.95

Forged Splined Rear Hub

WIN3784.....\$107.93



Direct Mount Front Hubs

DMI's GoldStar Front Hubs were the first hubs produced with a threaded dust cap. Unmatched quality and performance continue to make the GoldStar a popular choice.

Direct Mount Front Hubs Pr.

BlackDMISRC-1971\$419.14

Front Direct Mount Hub

Left (Black).....DMISRC-1969\$228.05

Right (Black)DMISRC-1968\$224.55



Direct Mount Hubs and Parts

13"/15" Lt. Wt. (Alum.)

Hub-Step Shaft
With Rotor MountWELC8088-LC.....\$265.68
No Rotor Mount.....WELC8088-RC\$265.68

Hub-Straight Shaft

With Rotor MountWELC8088-LT\$265.68
No Rotor Mount.....WELC8088-RT\$265.68

Weld Ultra Hub

13"/15" 3-Spoke Lightweight Hub Straight Shaft w/3 Lug Rotor Mount Aluminum WELC8088-LT3...\$296.84

13"/15" 3-Spoke Lightweight Hub Straight Shaft No Rotor Mount Aluminum WELC8088-RT3...\$296.84



Front Hub Replacement Bearing & Races

• Aircraft Material • Precision Ground • Tight Tolerances
• Works In Either Oil Filled Or Grease Packed Hub App
Front Hub Bearing.....KRP-1230.....\$12.95
Front Hub Race.....KRP-1235.....\$12.50

Hub Replacement Parts

VMAC Front Hubs utilize only the best Seals and O-Rings to ensure proper sealing. Replacement Hub Caps are 6061 T-6 Material and Anodized for added protection.
• Double Wall Seals. • Buna O-Ring.

Front Hub Dust Cap.....KRP-1240.....\$22.44
Front Hub Spiral Lock.....KRP-1245.....\$5.00
Front Hub Cap O-Ring.....KRP-1250.....\$3.00
Front Hub Seal.....KRP-1255.....\$8.00

Billet Aluminum Combo Steering Arm

The fully radiused design gives optimal weight savings without sacrificing strength. The 1" Forward Drag Link Hole Design gives you added clearance and a better turning radius.
• 3D CAD Designed • Fits 3 1/4 Spindle Bolt Spacing
SilverKRP-1300.....\$60.00
Anodized Black.....KRP-1305.....\$65.00

Billet Aluminum Right Front Steering Arm

It is a direct match for the VMAC Racing Combo Arm. Made and designed exactly the same as all VMAC Racing Products are, with one thing in mind, Optimal Weight Savings, and Ultra Strong.

• 3D Cad Designed • Fits 3 1/4 Spindle Bolt Spacing
SilverKRP-1310.....\$35.00
Anodized Black.....KRP-1315.....\$40.00

Direct Mount Front Hub Nuts

Manufactured with a large flange to distribute even pressure that ensures your Wheels stay tight. 3/8-16 National Coarse Threads. 6-Point 9/16 Hex Head. Zinc Plated.
KRP-1260.....\$1.50

Aluminum Front Spindles

Front Spindle Kit

WIN3622...\$153.99

Front Spindle Kit w/Titanium Shaft

WIN3622T\$174.95

Spindles

Spindles are forged for increased strength. All Spindles now include DMI's trick locknut. New design eliminates snout spinning.

Steel Snout.....DMISRC-2010\$199.40

Titanium Snout...DMISRC-2030\$265.89

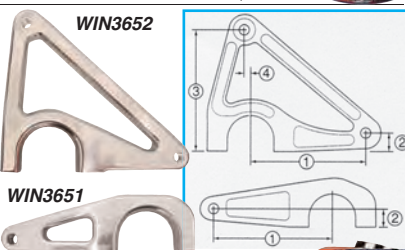

Sprint Steering Arms

1 - Dimension from tie rod center - line to king pin
2 - Dimension from tie rod center - line to spindle
3 - Dimension from drag link center - line to spindle
4 - Dimension from drag link center - line to center - line of king pin

Part #	Price	1	2	3	4
WIN3452	\$40.95	5.737"	.981"	6.000"	.598"
WIN3451	\$22.95	5.737"	.981"	N/A	N/A
WIN3651	\$22.95	5-1/2"	5/8"	N/A	N/A
WIN3652	\$41.95	5-1/2"	5/8"	6 3/8"	1/2"



Thermal Hood Blanket

It will help keep your Motor up to racing temp and protect that expensive engine. Easily installs in seconds. Comes In Black Only. Fits Any Sprint Car. Side Flap Snaps Up So Your Headers. Don't Burn Your Engine Blanket.
KRP-2610\$212.44

Tail Tank Cooler

Made from Reflective Aerospace Material to block out the heat and keep your Methanol cool. Tight Contoured Fit. Velcro Front Strap Helps Keep The Tail Tank Cooler In Place. Fits 25, 28, 30, and 33 Gallon Tanks.
KRP-2615.....\$75.00

4130 Chromoly Tubular Rear Wing Tree

It features 3/4" O.D. Material and it's Heli-Arc Welded in a Jig Fixture to insure each one is exactly the same. Its Telescoping Inserts make this Wing Tree fully adjustable making height changes simple. The Wing Ram Tab is welded into place and the Welded Center gives it Optimal Strength. Fully Adjustable from 18" To 24" • 26" Wide. 3D CAD Designed.
Chromoly Tubular Rear Wing Tree...KRP-2300\$90.00
Replacement Tubular Insert (Ea.)...KRP-2305\$15.00

Chromoly Tubular

Rear Nose Wing Mounts Pair

Made from 4130 Chromoly Material and Heli-Arc Jig Designed to bolt from the Shock Tower to your Nose Wing Side Board. These help clean up the air under the Nose Wing. Sold as a pair.
KRP-2350.....\$40.00

Chromoly Twist In Top Wing Post Pair

They are made to let your Wing slide back and forth with ease. Heli-Arc Jig Welded and Zinc Plated for added protection. 12" Long • Bright Cad Plated
KRP-2345\$45.00

Direct Mount Front Hub Studs

They are made from only the best Grade 8 Material. 3/8"-16 NC Precision Cut Threads and Black Oxide Coated for added protection. These are a direct replacement for your VMAC Hubs. Low Profile Button Style Head. 3/8-16 National Coarse Threads. Precision Ground.
KRP-1265\$2.00

Left Front Rotor Bolts

Made to attach your Left Front Brake Rotor to your Front Hubs. Manufactured using Grade 8 Material. 82" Tapered Allen Head Cap Screw with 1/2-20 National Fine Threads.
• Black Oxide Coated
• Machined Threads
• Precision Ground
KRP-1270.....\$2.00

Steel King Pin .859

DMISRC-2039\$22.93

King Pin Cap Short

DMISRC-2045B.....\$7.11

King Pin Cap Long

DMISRC-2055\$4.47

King Pin Bearing and Race Kit

DMISRC-2003\$24.35

Front Spindle Wrench

Made to fit sprint front spindle bearing retaining nut.
WIN3621.....\$20.99



Bert Sprint Transmission

The new Bert Sprint Transmission assembly weighs less than 36 lbs, including 6-1/2" flywheels, bellhousing, starter, transmission, torque ball coupler, hydraulic clutch master.

- All new clutch and gear system • A true neutral
- A direct drive that give you the same power response.
- One lever does it all. First, Neutral, and Direct.
- Now Sprint Cars can use the same dependable set-up that cranks up countless Late Models, Modifieds, and other race cars every weekend.
- Over all length of 9.625" from fire wall to center of U-joint.

Sprint Transmission.....BERSPZ.....**\$3226.66**

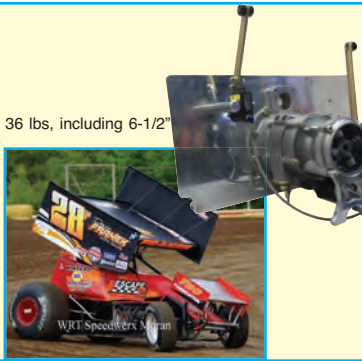

Super Bird Cages

VMAC Super Bird Cages are made from A-206 Aluminum Alloy. The 1-piece design makes these Bird Cages stronger & lighter than anything else on the market. VMAC's Very Own 28mm Angular Bearing. Black Powder Coated. Tight Ratio Pickups. Grade 8 Aircraft Hardware. Machined Flat On Top Of Both Bird Cages For Easy Timing. Right And Left Side Bkt Mts.

Pair.....KRP-1700.....**\$389.95**
 Left Side.....KRP-1705.....**\$212.44**
 Right Side.....KRP-1710.....**\$212.44**



12 Volt Racing Battery

Voltage: 12 volts

- Pulse Cranking Amps (PCA) 904
- 360 Cold Cranking Amps

Size: 5.8" L x 3.4" W x 5.8" H. Min Weight: 11.5 lbs.

Warranty: 2 yr pro-rated, 1st year Free replacement for street and competition purposes.

Standard.....BRLB14115.....**\$169.99**



Swedged Alum. Radius Rods

Lightweight Rods for Sprint Cars

- 1" O.D. x 5/8" 18".....RBBRRP-0100-18.....**\$12.95**
- 1" O.D. x 5/8" 18.5".....RBBRRP-0100-18.5.....**\$12.95**
- 1" O.D. x 5/8" 19".....RBBRRP-0100-19.....**\$12.95**
- 1" O.D. x 5/8" 19.5".....RBBRRP-0100-19.5.....**\$12.95**
- 1" O.D. x 5/8" 20".....RBBRRP-0100-20.....**\$12.95**
- 1" O.D. x 5/8" 20.5".....RBBRRP-0100-20.5.....**\$12.95**
- 1" O.D. x 5/8" 21".....RBBRRP-0100-21.....**\$12.95**
- 1" O.D. x 5/8" 21.5".....RBBRRP-0100-21.5.....**\$12.95**
- 1" O.D. x 5/8" 22".....RBBRRP-0100-22.....**\$12.95**
- 1" O.D. x 5/8" 22.5".....RBBRRP-0100-22.5.....**\$12.95**
- 1" O.D. x 5/8" 23".....RBBRRP-0100-23.....**\$12.95**
- 1" O.D. x 5/8" 23.5".....RBBRRP-0100-23.5.....**\$12.95**
- 1" O.D. x 5/8" 24".....RBBRRP-0100-24.....**\$12.95**
- 1" O.D. x 5/8" 24.5".....RBBRRP-0100-24.5.....**\$12.95**
- 1" O.D. x 5/8" 25".....RBBRRP-0100-25.....**\$12.95**



Solid Torsion Bar 23"

- 23" x 3/4 .600.....SCHRT-B23SD0600.....**\$84.75**
- 23" x 3/4 .610.....SCHRT-B23SD0610.....**\$84.75**
- 23" x 3/4 .620.....SCHRT-B23SD0620.....**\$84.75**
- 23" x 3/4 .630.....SCHRT-B23SD0630.....**\$84.75**
- 23" x 3/4 .640.....SCHRT-B23SD0640.....**\$84.75**
- 23" x 3/4 .650.....SCHRT-B23SD0650.....**\$84.75**
- 23" x 3/4 .660.....SCHRT-B23SD0660.....**\$84.75**
- 23" x 3/4 .670.....SCHRT-B23SD0670.....**\$84.75**
- 23" x 3/4 .680.....SCHRT-B23SD0680.....**\$84.75**
- 23" x 3/4 .690.....SCHRT-B23SD0690.....**\$84.75**
- 23" x 3/4 .700.....SCHRT-B23SD0700.....**\$84.75**
- 23" x 3/4 .710.....SCHRT-B23SD0710.....**\$84.75**
- 23" x 3/4 .720.....SCHRT-B23SD0720.....**\$84.75**
- 23" x 3/4 .730.....SCHRT-B23SD0730.....**\$84.75**
- 23" x 3/4 .740.....SCHRT-B23SD0740.....**\$84.75**
- 23" x 3/4 .750.....SCHRT-B23SD0750.....**\$84.75**
- 23" x 3/4 .765.....SCHRT-B23SD0765.....**\$84.75**
- 23" x 3/4 .775.....SCHRT-B23SD0775.....**\$84.75**



28mm Angular Bird Cage Bearings

It is the only manufacturer with its own truly Angular Bearing. Manufactured to withstand the day to day abuse any Sprint Car Team has to offer. The 54 Precision Ground Ball Bearings are encased in a Hardened Steel Shell that makes these the best bearings on the market!

- Split Inner Races For Easy Maintenance
- Precision Ground Ball Bearings
- Super Seal Outer Seals
- 100mm OD • 28mm Wide



Torsion Bar Reamer

It is manufactured for accuracy. The heart of the Reamer is its 4340 Tool Steel Industrial Cutter. Each Flute is precision ground for perfect cutting and accuracy. The Stem is made to come apart so it's easy to store. Machined at the Handle End is a 3/4 Hex so you can easily cut through your Bushings. Don't get caught in the Pits or the Shop without one. Billet Aluminum Construction. 2-Piece Take Apart Design Makes For Easy Storage. Anodized Black For Added Protection.

- Sprint Car TB Reamer 1-1/8" ..KRP-2500 ..**\$199.95**
- Midget TB Reamer 1".....KRP-2503 ..**\$199.95**



30" Hollow Torsion Bar

- 1-1/8-30" 950 Rate.....SCHRT-B30HW-0950.....**\$115.00**
- 1-1/8-30" 975 Rate.....SCHRT-B30HW-0975.....**\$115.00**
- 1-1/8-30" 1000 Rate.....SCHRT-B30HW-1000.....**\$115.00**
- 1-1/8-30" 1025 Rate.....SCHRT-B30HW-1025.....**\$115.00**
- 1-1/8-30" 1050 Rate.....SCHRT-B30HW-1050.....**\$115.00**
- 1-1/8-30" 1065 Rate.....SCHRT-B30HW-1065.....**\$115.00**



Hollow Torsion Bar 26"

- 26" x 7/8 .700.....SCHRT-B26HW0700.....**\$112.75**
- 26" x 7/8 .725.....SCHRT-B26HW0725.....**\$112.75**
- 26" x 7/8 .750.....SCHRT-B26HW0750.....**\$112.75**



Torque Tube

& Drive Shaft Checker

We have all rolled our Drive Shaft or Torque Tube on the ground trying to see if it was bent and couldn't tell. Well here is the answer, with Precision Ground Bearings and a Sturdy Aluminum Base this Checker will eliminate any questions whether your Drive Shaft, Radius Rod, Torsion Bar, or Torque Tube is bent.

KRP-2560.....**\$79.95**



Torsion Bars Hollow Titanium

There is a difference when you combine the best material, superior machining and the finest heat treating in the world. Winters hollow torsion bars out perform and out last all others! All torsion bars are available in various sizes.

18"WIN2594T-18.....**\$390.95**

16"WIN2594T-16.....**\$390.95**

Sprint Lightweight Torsion Stop

BRP4508...**\$42.20**



Torsion Stops

- A.) 1-3/4" 7075-T6 Forged Alum. Stop 1-3/4" ..WINSNC2140
- B.) 2" 7075-T6 Forged Alum. Stop 2".....WINSNC2150
- C.) 1-3/4" Forged Steel Stop 1-3/4".....WINSNC2160
\$19.95
- D.) 1-3/4" Forged Titanium Stop 1-3/4".....WINSNC2160T
\$81.95
- E.) 2" Forged Steel Stop 2".....WINSNC2170
\$19.95
- F.) 2" Forged Titanium Stop 2".....WINSNC2170T
\$80.99



Billet Front Torsion Bar Stops

It are truly a piece of machining art. Made from 2024 Aircraft Aluminum Material and Precisionally Machined to perfection. Comes Complete with Grade 8 Hardware.

- Billet 1 3/4" Split Front Torsion Bar Stop
KRP-1140.....**\$35.00**
- Billet 1 3/4" Split Front Torsion Bar Stop (Anodized Black)
KRP-1145.....**\$40.00**
- Billet 2" Split Front Torsion Bar Stop
KRP-1150.....**\$35.00**
- Billet 2" Split Front Torsion Bar Stop (Anodized Black)
KRP-1155.....**\$40.00**



Sprint Axle Spacer Kit

10 Piece Axle Spacer Kit
WIN3558.....**\$54.95**



Sprint Axle Spacers & Kits

- Description.....7075-T6 Aluminum
 - 3/8" Spacer.....Straight...WIN6683".....**\$12.95**
 - 7/8" Splined Spacer.....Straight...WIN6686".....**\$17.95**
 - 1-1/2" Splined Spacer.....Tapered...WIN6684".....**\$17.95**
 - 1-7/8" Splined Spacer.....Straight...WIN6687".....**\$20.95**
 - 2" Splined Spacer.....Tapered...WIN6685".....**\$30.95**
 - 2-3/8" Splined Spacer.....Straight...WIN6688".....**\$23.95**
- *Sprint spacers are available in magnesium.
Add prefix 'K' to part # example: WINK6683.



Torsion Bar Bushings

Oil lite bronze can also be used as a sway bar bushing.

- Bar ODTube IDMaterial.....Part #
- 1 1/8"1.250"BrassBEA6000.....**\$4.25**
- 1 1/8"1.250"NylonBRP264.....**\$8.98**



LPS Steel Torsion Stops

- 2 1/2" straight.....LPS4.....**\$30.95**
- 2 1/2" curved.....LPS6.....**\$30.95**
- 2" curved.....LPS11.....**\$30.95**
- 1 3/4" curved.....LPS14.....**\$30.95**



Axle Hex Nuts

- Description.....Left.....Right
- SprintWIN6121L **\$17.95**.....WIN6121R **\$17.95**
- Sprint (For Ultralight Axle).....WIN6121L-UL **\$54.95**.....WIN6121R-UL **\$54.95**
- Sprint, Mag. (For Ultralight Axle).....WINK6121L-UL **\$77.95**.....WINK6121R-UL **\$77.95**



SPRINT SECTION / DRIVELINE

Torque Tubes

Aluminum Torque Tube w/ H.D. Base - 28"
DMISRC-2390.....\$156.32

Aluminum Torque Tube w/ L.W. Base - 28"
DMISRC-2393.....\$156.32



New Style Torque Ball Housing & Collar w/Insert

It is the Ultimate Torque Ball Housing available today. If you are tired of replacing magnesium housings - Get the Ultimate Torque Ball Housing! DMISRC-2308...\$191.30



Torque Ball Safety Blanket

Fire resistant safety blanket designed by Jason Meyers Racing protects drivers legs and feet in the event of a U-joint failure. Ballistic nylon covered blanket weighs just 1-1/2 lbs. and has quick release adjustable straps which allow blanket to be removed easily for servicing torque ball and u-joint. Blanket includes two mounting brackets, mounting studs, nuts, and installation instructions.
ALL55220...\$334.99



Aluminum Rear End Cover Nuts



Manufactured from 9/16 Billet Alum Hex and Precisionally Machined. One of the added features is that the Rear Cover Nut is completely drilled all the way through and then Radius Machined in the Head of Optimal Weigh Savings and gives it that trick VMAC Racing Finish.
KRP-2220.....\$4.00



Splined Rear Wheel Centers

Black Widow Alum. Splined Rear Ctr for Weld/Sanders.
DMISRC-1979A.....\$177.91

Black Widow Alum. Splined Rear Ctr for Weld/Sanders. Gold
DMISRC-1979AG.....\$177.91

Torque Ball Housing Stud and Highnut Kit for DMI SRC-2305

DMISRC-2307.....\$36.74



Rear End Saver

Made From 6061 T-6 Alum. Anodized Black For Added Protection. Comes complete with all hardware.
KRP-1630.....\$60.00



Torque Tube Nut Kit (6)

These Special 6-Point Flange Aircraft Jet Nuts have a built-in Washer and work perfect with VMAC Racing's Torque Tube Stud. Comes in a set of (6).
KRP-1625.....\$10.00



Torque Tube Stud Kit

DMIRRC-2006....\$20.57



Splined Rear Wheel Centers

Every Alum Splined Rear Axle needs these. These Chromoly Axle Spacers are a must to install before you slide on your Bird Cages. Precision machined inner diameter for exact fit on any Axle. Comes In 3/16 or 9/16 Thickness. Zinc Plated For Added Protection. Works On Winters, DMI, & Frankland Axles.

3/16 Spacer.....KRP-2210.....\$10.00
9/16 Spacer.....KRP-2215.....\$12.00



Driveshaft

20", 22", 24", 26", 28", 30", and 31-1/2"



Steel, Solid 10-16 Spline, 1.125 OD.....WIN5988 ...\$85.95
Titanium, 10-16 Spline, 1.125 OD.....WIN5988T...\$422.95



Lower Shaft

Standard Shaft, Open Drive.....WIN5003-02...\$108.95
Heat Treated Shaft, Open Drive...WIN5003.....\$124.95
Standard Shaft.....WIN6249.....\$110.28
Heat Treated Shaft.....WIN6249HT...\$131.23



Std Shaft, Sprint Int. Coupler.....WIN6678-01...\$104.95
Heat Treated Shaft, Sprint Int. Coupler...WIN6678-03...\$127.95
Titanium Shaft, Sprint Int. Coupler.....WIN6678T.....\$299.95



Axle Sprint Alum 52-1

Aluminum Live Axle (Specify Offset)
WIN5778A-52-1.....\$578.95



King Pin Caps

WIN1109-02A...\$3.07

WIN6476-02

King Pins

*Fits Sprint or Midget
Hollow King Pin.....WIN6476.....\$18.95
Steel King Pin cap.....WIN1109.....\$3.95
Hollow King Pin.....WIN6476-02...\$16.52
Aluminum King Pin Cap.....WIN1109-02A...\$3.07
10" Spindle Bushing (.859 ID).....WIN7515.....\$2.90
Thrust Race .030 Use w/WIN7511...WIN7512.....\$1.83
Roller Thrust Bearing.....WIN7511.....\$3.57
.005" Thick Shim, Thrust Bearing.....WIN7514.....\$0.74



10" Ring Gear

12 Bolt Magnesium Shifter

The Sprint Rear is available with hubs, in-out shifter, and with magnesium castings.
4.86 R&P Standard...WINK637S...\$1873.95



"Pro Eliminator" 10" Ring Gear 12-Bolt Quick Change Rear End Assemblies

Magnesium, open tube assemblies have 10" ring gears with internal right side bell, shifter, Posi-Lock assembly (WIN8104), aluminum axle (WIN8122), sealed front bearing (WIN8141), pinion nose roller bearing (WIN8143), gear cover (WIN8185), and lightweight side bells (WIN8185) unless otherwise specified.

WINK837S.....\$1401.86

Additional Options (Extra)

8104, 8106, 8141, 8143, 8153, 8185, 8216
8104, 8122, 8141, 8143, 8185, 8216
8104, 8106, 8116, 8122, 8137, 8141, 8143, 8163
8104, 8116, 8122, 8137, 8141, 8143, 8163, 8208, 8153



Aluminum Slip Yoke Assembly

WIN3700.....\$161.95



Assembly Part #s

Sprint Outside Ball Aluminum Assy
WIN3714.....\$130.95

Sprint Outside Ball L/W Assy
WIN3475.....\$156.95



Closed Drive Line

Alum Collar, 3" Alum Torque Tube 28"
WIN6661-02.....\$113.95

Mag Collar, 3" Alum Torque Tube 28"
WINK6661-02A.....\$178.95

Mag Collar, 3" Mag Torque Tube 28"
WINK6661-02.....\$293.95

Aluminum Torque Ball
WIN6654.....\$106.95

Mag Torque Ball
WINK6654.....\$148.95



Breather Can

Weighs .70 lbs. Breather element can be cleaned and reused. Fully welded lightweight aluminum. #6 an breather line. #8 an return line. Small, compact design that will not detract. From the appearance of your car. 360° mounting bracket included to allow.
WIN4763.....\$153.95



Inspection Plugs



Quick change side oil level plug
BRP908.....\$23.36



1" hex head makes it easy to remove plug from center section to inspect.
BRP909.....\$23.95



Rear Cover Nuts

Black Aluminum.....WIN7794ASBK\$2.94
3/8-16 x 1 3/4" Stud.....WIN7802.....\$2.13



Breather Assembly

Pro Eliminator Breather Assembly (Side Mount)
WIN2966.....\$21.95

Pro Eliminator Breather Assembly (Top Mount)
WIN2967.....\$21.46



Rear End Shifter Cables

Super Shifter Lever, Assembly (Sprint or Midget)
WIN3232.....\$109.95

Coupler

10-10 Coupler Sprint/Midget
Steel.....WIN5987.....\$41.95
Aluminum...WIN5987A...\$45.95



Stub Shafts

Standard Stub Shaft.....WIN6250.....\$96.64
Heat Treated Stub Shaft...WIN6250HT...\$122.95



Options for "Pro Eliminator" Quick Change

Posi-Lock Assembly.....WIN8104...\$26.56
Heat Treated Lower Shaft.....WIN8106...\$28.46
Bushings in Lower Shaft.....WIN8116...\$36.75
Double Row Bearing Carriers.....WIN8118...\$95.55
Titanium Thru-Bolts.....WIN8127...\$147.00
Titanium Lower Shaft.....WIN8128...\$213.80
Heavy Duty Gear Cover.....WIN8137...\$62.62
Special Front Bearing.....WIN8141...\$23.45
Roller Bearing on Pinion Nose.....WIN8143...\$18.38
Lightweight Side Bells.....WIN8147...\$84.53
Titanium Shifter Shaft.....WIN8150...\$84.53
Lightweight Aluminum Axle.....WIN8153...\$44.10
Splined for Brake Mount.....WIN8158...\$44.10



SPRINT SECTION / COCKPIT

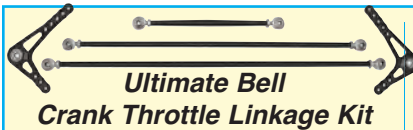

Ultimate Bell Crank Throttle Linkage Kit

The Trick Swaged Radius Rod links have right and left hand threads for optimum adjustment. Completely Anodized Black. Universal Kit Fits All Chassis.

- Crank Throttle Linkage Kit W/Steel Heims KRP-2005.....\$95.00
- Crank Throttle Linkage Kit W/Aluminum Heims KRP-2010.....\$115.00



Billet Throttle Arms

Available For 5/16 & 3/8 Throttle Shafts. Works On Hilborn, Kinsler, & Engler Injectors. Stainless Steel Hardware. Anodized Finish.

- 5/16 Billet Throttle Arm (Black)KRP-2065\$15.00
- 3/8 Billet Throttle Arm (Red)KRP-2070\$15.00

Steering Gear Locators

All VMAC Racing's Steering Gear Locators are manufactured from 6061 Billet Aluminum. All four styles have been Completely Radius Machined and the Mounting Holes Chamfered for easy installation.

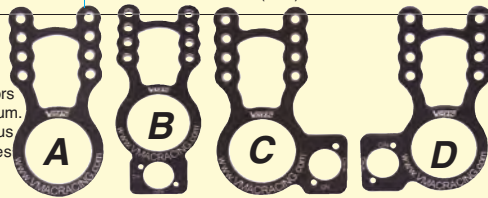

- A. Standard Steering Gear Locator.....KRP-1425.....\$17.95
- B. Bottom Fuel Shut Off Steering Gear Locator.....KRP-1430.....\$24.95
- C. Right Side Fuel Shut Off Steering Gear Locator.....KRP-1440.....\$24.95
- D. Left Side Fuel Shut Off Steering Gear Locator.....KRP-1435.....\$25.00

1/2 Steering Box Mount

Designed to make installing and removing your box easier and faster. Fully Machine Radiused from 6061 T-6 Billet Aluminum. Black Anodized Finish. 3-D Cad Designed. Ultra Lite Weight...KRP-1420...\$40.00

Cross Shaft Throttle Linkage Kit

This kit includes 2 Pillow Blocks that are installed on the bridge of your Injector, 2 Center Throttle Arms, 2 Fully Adjustable Turnbuckles with Aluminum Heims, 3/8 Stainless Cross Shaft, 3/8 Throttle Arm, and an Idle Adjustment Stop. KRP-2000.....\$225.00

Tubular Throttle

The 10/32 Bolt that is welded at the end of the Toe Return that is perfectly located to make the Throttle Linkage Assembly easy and fast. The Toe Return is welded down close to the top of your foot so your Driver will have optimum throttle control. KRP-2075.....\$50.00

Panel Mount Ball Valves

Great for dash mounted fuel shutoff. Complete with offset handle.

- 6 AN Male Fittings.....PET09-0910.....\$115.09
- 6 AN Push-On Fittings ..PET09-0912.....\$115.09
- 8 AN Male Fittings.....PET09-0930.....\$115.09
- 8 AN Push-On Fittings ..PET09-0932.....\$115.09

Inline Ball Valves

Made from aircraft alum, valves utilize hardcoated alum balls & bodies along with Teflon seals. Make fuel or oil shutoff easy, while allowing full flow when opened.

- 8 AN x -8 AN Sm Body.....PET09-0920.....\$115.09
- 8 push-on x -8 push-on Sm BodyPET09-0922.....\$115.09
- 8 AN x -8 AN Large Body.....PET09-0940.....\$121.16
- 8 push-on x -8 push-on Large Body..PET09-0942.....\$121.16

15" Steering Wheels

Ultra LW Uncoated Alum

Half the weight of std wheels Shot peened rim for good grip w/o wrist strain w/bumps- DishedLON56822...\$61.83

Drilled- Flat - Sprint LON56866...\$84.14

Steering Wheel Spacers

3/4".....LON56703...\$12.75

Steering Quick Disconnect

High quality disconnect features multi spline design for a more accurate fit. Bolts to Sweet, Profile or GME steering box. SWE801-70005.....\$90.45

Multi Splined Quick Release Steering Disconnect

Complete assembly fits Nields/Profile/Lee Boxes BRP2129.....\$68.28

2 Bolt Pump Adapter

It uses a 2-bolt pattern and is used on sprint car mid-plates with a raised camshaft or normal camshaft geometry. KRCKRC19552000.....\$67.89

3 Bolt Pump Adapter

It uses a 3-bolt Hilborn pattern and will bolt directly to the rear of the current Peterson, Johnson, Wulff, Nutter, and several other manufacturers that have a Power Take-Off built into the rear of their dry sump pumps. This is also our most popular sprint car mid plate adapter. KRCKRC19551000.....\$67.89



DMI's Race Kits

DMI's Race Kits are a handy way to purchase the necessary parts to build your racecar. All your favorite DMI components at a great package price - another way DMI has raised the bar in convenience and service.



Complete Race Kit.....DMI SRC-6000

- (1) 2-1/2" Front Axle - Eagle/Maxim Style.....DMISRC-1910.....\$269.77
- (2) Aluminum Spindle with Straight Steel Snout.....DMISRC-2000.....\$161.86
- (2) Steel King Pin - .859.....DMISRC-2039.....\$22.93
- (1) King Pin Bearing and Race Kit.....DMISRC-2003.....\$24.35
- (1) Combo Steering Arm - 5.5" x 1" Forward.....DMISRC-2085.....\$61.09
- (1) Single Steering Arm for SRC-2080 & SRC-2085.....DMISRC-2100.....\$36.81
- (1) Front 3 - Lug Rotor 10-7/8" w/Holes.....DMISRC-2710.....\$47.97
- (1) Brake Line Rock Guard.....DMISRC-2820.....\$8.55
- (1) LF Caliper Mount for 10-7/8" Rotor w/Allen Bolts.....DMISRC-2810.....\$14.65
- (1) Steel Tie Rod or Drag Link.....DMIRR-45-5-ST.....\$48.76
- (4) 5/8" Steel RH Jam Nut.....JAM010.....\$0.60
- (2) 5/8" Steel LH Jam Nut.....JAM010L.....\$0.85
- (1) New Style Torque Ball Housing & Collar w/Insert.....DMISRC-2308.....\$191.30
- (1) Aluminum Torque Ball.....DMISRC-2370.....\$112.34
- (1) Aluminum Torque Tube with HD Base 28".....DMISRC-2390.....\$156.32
- (1) Steel/Alum U-Joint Assembly Chevy & Mopar Gladiator Cross.....DMISRC-2345.....\$233.42
- (1) 4340 Steel Tubular Driveshaft - 30".....DMISRC-2430.....\$129.97
- (1) Small Double Bearing Birdcage Set.....DMISRC-2575.....\$415.43
- (1) Front Torsion Arm - Long.....DMISRC-2100.....\$54.55
- (1) Front Torsion Arm - Short.....DMISRC-2130.....\$52.10
- (2) Aluminum Torsion Stop - 1-3/4" Split.....DMISRC-2140.....\$34.35
- (1) LW Right Rear Torsion Arm - LW Eagle/Maxim.....DMISRC-2687.....\$64.30
- (1) LW Left Rear Torsion Arm - LW Eagle/Maxim.....DMISRC-2689.....\$65.07
- (2) Steel Torsion Stop - 1-3/4" Split.....DMISRC-2160.....\$41.54
- (1) 4130 Steel Jacobs Ladder w/Straps - 13-5/8".....DMISRC-2505.....\$71.80
- (8) Plastic Torsion Bushing for .095 Tubes.....DMISRC-2220.....\$5.04
- (2) 10 pc. Aluminum Spacer Kit.....DMISRC-2590.....\$73.54
- (1) Long Lightweight Pitman Arm - Angle Broach.....DMISRC-2260.....\$47.06
- (3) 1/2" x 1/2" Aluminum Tapered Spacers.....DMISRC-2095.....\$1.65



A.) Reservoir Tank Econo Round w/Roll Bar Mounting Bkt

KRCKRC91500000.....\$83.39

B.) Mounting Bkt, Replacement for Round Tanks

KRCKRC91510000.....\$106.67

C.) Reservoir Tank, Flat Surface Mt, -6 Fitting on RH Side Facing Tank..KRCKRC91515000.....\$106.67



Battery Pack Complete Kit

Includes holder for lightweight 9V battery, low oil pressure switch (20 psi), warning light, heavy duty mag kill switch with weatherproof switch cover, wire and terminals. LON45620...\$36.00



SPRINT SECTION / ENGINE

Billet Alum Front Motorplate

Made from 6061 Plate and Completely Machine Radiated, Anodized Black. Ultra Lite Weight. Fits All SBCs.
KRP-1500.....\$60.00



Rear Motorplate

Made from 6061 Aluminum, with machined Lightening Pockets. All mounting holes are drilled with the Torque Tube Ball Housing and Pump Holes being tapped. Fits all major chassis.
KRP-1510...\$160.00



Honeycomb Radiator Mounts

It's always hard to mount your Honeycomb Rad Protector until now. VMAC Racing has come up with these slick Plastic Bolts, Washers, and Nuts to get the job done. Easily installs in seconds. Heavy Duty Polyurethane Material. Extra Long To Mount Through The Thickest Rads.
KRP-2625\$10.00

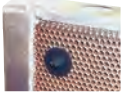

Radiator Honeycomb

Honeycomb screen mounts to front of radiator to protect from rocks and debris. Secure directly to radiator using ALL30085 mounting kit, sold separately. 19" x 26" x 1/2" thick.
ALL30158.....\$23.99

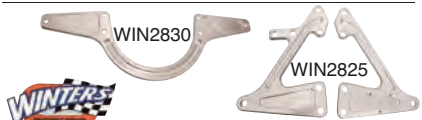
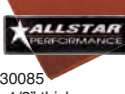

Aluminum Front Motor Plates

One Piece Front.....WINSRC-2830 ...\$67.13
Two Piece Front.....WINSRC-2825 ...\$69.95

Oil Tank Mounts

Upper Oil Tank Mount
WIN3981\$49.00
Lower Oil Tank Mount
WIN3982\$49.00



Timing Gear Covers

6061-T6 Heavy duty billet alum Std & raised cam (.391) configuration. 1000% machined. Cover available for MSD trigger ignition. Designed for SBC.

Standard offsetWIN4182\$269.99
Raised cam styleWIN4182R...\$269.99
For crank triggerWIN4183\$283.49
Raised cam style, crank trigger.....WIN4183R...\$283.49



Sprint Car Front Magneto Drive Assy

Front Magneto Drive Assembly has been designed to work with: Standard Shaver - Wesmar gear drive assemblies. Moroso cam driven dry sump pumps, as well as other commonly used oil pumps. Commonly used crank driven water pumps. MSD 12 LT Generator. Benefits Include: Increased timing accuracy. The ability to eliminate costly crank trigger systems. Improved access to Magneto for timing adjustments. Increased area at the rear of engine allows for induction system improvements
SBC, Non-Raised CamMOR60205\$2412.81
SBC, .390 Raised CamMOR60206\$2412.81



Sprint Car Billet Alum Timing Cover

Designed to work with all gear and chain cam drive systems, including Standard Shaver and Wesmar gear drive assemblies. Timing Cover's bolt pattern is designed to accept Moroso cam driven dry sump pumps as well as others. Is included in the Moroso Sprint Car Front Magneto Drive Assembly. Cover accommodates commonly used Sprint Car crank driven water pumps. Has a top timing port.

SBC, Non-Raised CamMOR60200\$287.79
SBC, .390 Raised CamMOR60201\$287.79



Peterson

Center Vent LW Tank w/Filter

It incorporates a center vent system which vents air from the oil out through the bottom of the tank. This tank has been proven in competition and includes the same filter package as our other popular sprint car tank. Total tank weight including filter is 4.7 lbs.

2.5 Gallon Male -12 AN fittings. Center Vent. Single return line. 1 Piece.
PET08-0867.....\$37.65
Dual return line. 1 Piece
PET08-0868.....\$771.18



LW Non Take Apart

Peterson's 2.5 gallon lw tanks weigh 3.2 lbs and includes inside baffles and de-aeration assembly. Used by Karl Kinser and Sammy Swindell.

2.5 Gallon LW tank, Male -12 AN fittings. Single return line...PET08-0037...\$353.78
Dual return linePET08-0038..\$377.26

Lightweight - Take Apart

Peterson's new lightweight take a part tanks use the same internal baffling as our race proven 1 piece tanks. Tanks are built with -12 AN male fitting. These tanks weigh only 3 ounces more than the one piece tank!
2.5 Gallon lightweight tank, Male -12 AN fittings.

Single return linePET08-0027 ...\$443.68
Dual return linePET08-0028 ...\$468.45



Super Flow High Speed Checker

Made for today's High Pressure Fuel Systems. The Extra Large 4" Gauge goes up to 160 lbs.
KRP-1900\$199.95



Outlaw Leakdown Tester

This unit comes complete with Barrel Valve and Engine Leakdown Tester Hoses. Anodized Black 14mm Spark Plug Adaptor. Industrial Grade Hardware. Easy To Read Large Liquid Filled Gauge.
KRP-1910\$145.00



Billet Down Nozzle Filter Kit

Machined from 6061 T-6 Billet. Comes Complete In A Set Of 8. Fit's Hilborn, Kinser, And Engler Nozzles. Hard Anodized For Added Protection.
KRP-1990.....\$59.95



Dual Gauge Leakdown Tester

Manufactured from only the best alloys and utilizing American Made Hardware.
KRP-1915.....\$120.00



Peterson Sprint Car Tank Bkt

This bracket is fabricated from aircraft quality aluminum and uses stainless straps for durability. Designed to mount any 6" dia tank to the front of SBC engine.
PET08-0105.....\$72.96



Sprint Car Air Box

Sprint box w/filter top 6 3/4" center spread**K&N100-8562* ..\$672.99
Sprint box w/carbon top 6 3/4" center spread**K&N100-8563* ..\$673.99
Side filter w/filter top only**K&N100-8564 ..\$478.99
Base Plate Only, holes are not pre cutK&N100-8565 ..\$212.99
Side filter w/carbon top only**K&N100-8566 ..\$525.99
Side filter w/filter top, no holes in base**K&N100-8567* ..\$623.99
Side filter w/filter top, 7" center spread**K&N100-8568* ..\$735.99
Small Sprint box w/filter top, no holes in base, fits two injectors**K&N100-8569* ..\$312.99
Medium Sprint box w/filter top, no holes in base, fits four injectors**K&N100-8570* ..\$369.99
*These are complete units base plate, side filter and top **Side filter is glued to top on all units



Straight Tube Design Headers

(Collector Dia/Length 3-1/2" x 13")

Tube Diameter	Std Chevy	Spread Port/DN	
1-3/4" - 1-7/8"	SCH1054LV	SCH1054LVSP	..\$279.95
1-7/8"	SCH1055L	SCH1055LDN\$229.95
1-7/8"-2"	SCH1055LV	SCH1055LVDN\$279.95
2"	N/A	SCH1056LDN\$229.95



Swept Forward Design Headers

(Collector Dia/Length 3-1/2" x 13")

Tube Diameter	Std Chevy	Spread Port/DN	
1-3/4"	SCH1024L	SCH1024LSP\$229.95
1-7/8"	SCH1025L	SCH1025LDN\$229.95
1-7/8"-2"	SCH1025LV	SCH1025LVDN\$279.95
2"	N/A	SCH1026LDN\$229.95



Beyea Custom Headers

23° Chevy

1-5/8" - 3"BEYDS231\$300.00
1-3/4" - 3"BEYDS233\$300.00



Spread Port 360-410 Sprints

1-7/8" - 3 - 1/2"BEYDSSP360-S2.....\$350.00
1-7/8" - 3 - 1/2"BEYDSSP410-1.....\$300.00

Beyea Custom Headers

Tri-Y Sprint

1-3/4" - 1-7/8" - 3"BEYDSTY23S2.....\$720.00
1-3/4" - 2" - 3"BEYDSTYSP360D2.....\$760.00



Quick Release Muffler Clamps

The Exhaust Rings are easily welded to any 3 1/2" Collector. The Stainless Exhaust Clamp has a low profile design. Weld On Friendly. Fits Any 3 1/2" Collector.
Exhaust ClampKRP-2110\$25.00
Exhaust RingKRP-2115\$20.00



Fuel Block

This unique design has three #6 Male Fittings out the top with one #8 out the end for your Return Line. What makes this better than the competition is at the opposite end of the #8 Return Fitting is another #6 Port for a Double High Speed System.
KRP-1930.....\$87.44



Replacement Flush Mt Down Nozzle Filter

This filter is a direct replacement for any Down Nozzle Filter Biscuit. Installs in seconds and has a 1/8 NPT Male Thread.....KRP-1995 \$5.00



SPRINT SECTION / BRAKES



Billet NDL Radial Mt

It is a compact, lightweight, and rugged caliper that provides strong clamping force from four 1.75" stainless cup pistons. The bodies are fully CNC machined from billet with internal fluid ports that eliminate external fluid tubes.

Bore Size .Rotor Width

1.75".....0.81".....WIL120-13406-N..\$191.65
1.75".....0.38".....WIL120-6453-SI..\$144.00

Forged Narrow Mount Dynalite

It represent the next generation of calipers available as an upgrade or direct replacement for the popular Narrow Mount Dynalite models series with 3.50" mounting. NDP calipers combine superior strength with several new performance enhancements to make these the best "Dyna" series calipers ever built.

Bore Size .Rotor Width

1.75".....0.81".....WIL120-11572.....\$116.94
1.75".....0.38".....WIL120-11571.....\$116.94

DynaPro Single Billet

It's combine superior strength with several new perf enhancements to make these the best "Dyna" series calipers ever built. The DPS is perfect for compact high perf braking as required in Open Wheel, Drag, Modified, Kart & Off Road apps.

Bore Size .Rotor Width

1.75".....0.38".....WIL120-9689.....\$90.60
1.75".....0.38".....WIL120-9687.....\$90.60

Billet Narrow Dynalite Radial Mt Nickle Plated

Bore Size.....Rotor W.4 Piston Radial Mt Side Inlet
1.75/1.75.....0.81.....WIL120-13406-N.....\$191.65
1.75/1.75.....0.38.....WIL120-13405-N.....\$191.65
Radial Mt Bkt Kit - 3.50" Mt Center, 12.19" Rotor Dia
WIL250-13365.....\$68.69

DynaPro Single Nickle Plated

Bore Size ..Rotor Width
1.75/1.75.....0.38..2 Piston 3.25" Lug Mt
WIL120-10188-N.....\$102.44

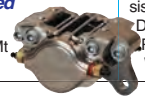

Clamp On Magnesium Inboard Rotor Mount

Use with all 8 on 7" bolt circle rotors.
WINK6986-03.....\$188.99

Sprint Rotor Mount

Magnesium floating 46 splined inboard rotor mount. 1 piece rotor mount, use with all 8 on 7.00 bolt circle rotors.
WINK6396S-1.....\$162.46

Caliper Mt

Left Front Caliper Mount for 10 7/8" Rotor. Fits Spindle WIN3622 & WIN3622T.

A: 3-1/4" • B: 3-1/4" • C: 1-9/16"
WINS2810.....\$11.95



Nylon Brake Line Kit

Quickly plumb any race car using an Allstar Nylon Brake Line Kit. Kit extends from the master cylinder to the caliper and includes 35 feet of 3/16" line, compression ends, unions, tees and 1/8" NPT fittings. Race proven for years. Not for street use.
ALL48030.....\$64.99

Dynapro Radial Sprint Inboard Brake Kit

A fully engineered bolt-on brake system for sprint car quick change rear wheels with 3.00 x 46 splined axles. With Super Alloy .810 vented discs and a newly designed dynamic mount rotor axle clamp, are the lowest rotating weights available for Sprint racing. The LW advantages of the Super Alloy rotor are combined with high durability & long wear. Forged billet Dynapro radial mount calipers with Composition Metallic pads, produce superior stopping power and consistent fade-free response. Kit includes Axle Clamp with Dynamic Mt Rotor Adapter assembly with T-nuts & Radial Mt Bracket & mounting hardware.
WIL140-11206.....\$624.57

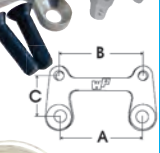
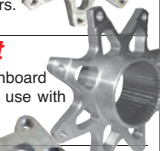

Remote Master Cylinder Kits

Allows you to place reservoirs in an easy to reach location. Great for race cars.

5/8" bore.....WIL260-3372.....\$67.48
3/4" bore.....WIL260-3374.....\$67.48
7/8" bore.....WIL260-3376.....\$67.48
1" bore.....WIL260-3378.....\$67.48
1-1/8" bore.....WIL260-3380.....\$67.48

Rebuild Kits

5/8".....WIL260-3880.....\$18.69
3/4".....WIL260-3881.....\$18.69
7/8".....WIL260-3882.....\$18.69
1".....WIL260-3883.....\$18.69
1-1/8".....WIL260-3884.....\$18.69

Master Cyl Return Spring Kit

It is made to keep the driver from burning the brakes off the car. A high strength zinc coil spring with an anodized black billet retainer make this the nicest master cyl return spring kit on the market.
KRP-2400.....\$19.95

Splined Right Rear Rotor Mt

Tired of always having trouble getting that right rear rotor on and off, well here is a fix. This will let you use any left front rotor on it. No matter if the rotor is bent or wrapped this mount will slide on and off with no problems. Made from Aircraft 6061 T-6 Alum.
KRP-2430.....\$45.00

Steel Convo Left Front Brake Rotors

They are designed for optimum stopping power. The Convolved 3/8" Thick Design saves weight but doesn't sacrifice stopping power. The 3 Bolt Design bolts directly to your Front Hub & is direct replacement for either Alum or Titanium Rotors.
10-1/4" diameter.....KRP-2465.....\$85.00
10-3/4" diameter.....KRP-2470.....\$85.00

Aluminum Left Front Brake Caliper Mts

The Aircraft 2024 Material is precisionally machined with an Arched Bridge to help keep the Caliper true and straight giving optimal braking power. Available for either 10" or 11" Rotors. 3 1/4 Bolt Spacing. Anodized Black. Comes With 2 Flush Head Allen Bolts.

Left Front Brake Caliper Mount
(10" Rotor).....KRP-2410.....\$15.95
(11" Rotor).....KRP-2415.....\$15.95

Right Rear or Left Rear Brake Caliper Mts

Machined from 6061 T-6 Alum. These are the Brake Mts you will need to go with either style of VMAC Racings Birdcages. Made to work on the left or right birdcages.
Standard.....KRP-1735.....\$20.00
Red Devil.....KRP-1740.....\$20.00

Left Front Caliper Mount

Use with 10-7/8" Rotor. Fits Spindle WIN3622 & WIN3622T.
WINS2810.....\$11.95

Aluminum Birdcage Caliper Mount

WINS2574.....\$16.80

Rotors

Aluminum 3 Hole Mount Rotors

Willwood's 3 hole mt rotors are precision CNC machined from high strength billet plate. These rotors fit the popular 3 x 5.00" mt circle found on most sprint and midget front hubs.

Diameter..Width.....Bolt Circle..Hole Type.....Weight LBS..Rotor Type
10.95".....0.31".....3 x 5.00".....0.516".....1.8.....DRILLED.....WIL160-3327.....\$56.24
10.20".....0.31".....3 x 5.00".....0.516".....1.6.....DRILLED.....WIL160-3411.....\$56.24

Splined Axle Mount Aluminum Rotors

Willwood's 3.00" x 42 splined axle mount rotors are manufactured from the same high strength billets with the same precision as our 3 hole mount front rotors.

Diameter.....Width.....Bolt Circle.....Weight LBS.....Rotor Type
10.95".....0.31".....3 X 42 SPLINE.....2.3.....DRILLED.....WIL160-3275.....\$49.90
10.20".....0.31".....3 X 42 SPLINE.....1.9.....DRILLED.....WIL160-3270.....\$62.44

Dynamic Mount Drilled Steel Rotors

Dynamic mounting is the most effective method of eliminating all types of thermal stress and distortion in steel rotor applications. These rotors are machined with mounting slots that are used with special t-nuts and bolt kits.

Diameter.....Width.....Bolt Circle.....Hole Type.....Lug I.D.Weight LBS.....Rotor Type
12.19".....0.35".....8 x 7.00".....SLOT.....6.56".....4.8.....SCALLOP.....WIL160-5538.....\$137.42
11.75".....0.35".....8 x 7.00".....SLOT.....6.56".....4.5.....SCALLOP.....WIL160-5855.....\$137.42

Sprint - Open Wheel Live Axle Clamp-On Rotor Mount

Lightweight and strong, these clamps provides sturdy fixed position mounting for rear inboard brake systems on live axle sprints and modifieds.

Rotor Bolt Cir.....Axle Spline.....Rotor Mt Hole.....Rotor Bolt Kit #.....Axle Clamp.....Part #
6 x 5.50".....3.00 x 46 Spline.....5/16".....(3).....WIL270-9761.....\$295.00
Dynamic Mount Bolt Kit Included

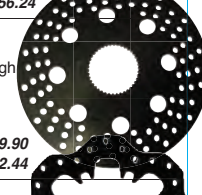
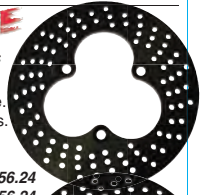

Crate Motor Section

DRIVE LINE

Crate Motor Flywheel

With many tracks mandating crate motors, Bert is there to work with those racers. Here Bert presents the first externally balanced flywheel to couple your crate motor to a Bert transmission. With horsepower limited, the efficiency of the Bert transmission is more important than ever!

Crate Motor Flywheel ..BER311-NC-EXT...\$151.35
Shims N.S. ChevyWIN62321\$2.80

Racing Flexplates

Chevy Flexplates are .035" thicker than stock and the ring gear is welded to both sides for added strength. Dual GM bolt patterns are sized for stock 3/8" bolts but can easily drilled to 7/16" for added strength. SFI 29.1 approved.

Chevy
External Dual Bolt Pattern, 168T
Only for 1 Piece Rear Side Engines
TCI399773.....\$118.04

Crate Flywheel

WIN63844-18.....\$133.65

Drive Flange Modified

New Chevy 3 Inches
BER007-NC.....\$84.48

Flywheel Shim

New Chevy
BER324-NC.....\$1.27

Crank Couplers Short

WIN62350-18...Late SBC 18 Spline\$72.70

Flywheel Shim

WIN62321.....\$2.80



Extra Long Dowel Pins

These 2-inch long GM dowel pins are a must for any applications running a mid-mount plate to insure that the transmission bellhousing is properly aligned with the engine. Kit contains two black zinc coated and precision ground dowel pins. These extra-long dowel pins are a must for any application running a mid-mount plate to ensure that the transmission bellhousing is properly aligned with the engine. Bellhousing Dowel Pins, .625 in. Diameter, 2.0 in. Length, Straight, GM, Pair.
TCI930055.....\$18.05



Bert Flywheel Bolts

6 pcs 12 pt 1" x 7/16-20
BSC80624\$12.00
1" works w/most 1 Pc Flywheels.

EXHAUST



602 Crate Dirt Modified Headers

DIRT Approved
Straight Tube 4-1 Header 1-5/8" x 3" Up Swept

BEYNEDMUS602-DL.....\$280.00



Tail Pipe Kit

Crate 602 Upswept Tail Pipe Kit
use with Beyea Headers
BEYNEDMTPKUS602-BEY.....\$120.00



Crate Mufflers

Dirt Modified Muffler
3" In, 3" Out; 8" Body
BEYMU3DM.....\$85.00

Dirt Modified Muffler - Dirt Legal
3" In, 3" Out; 8" Body
BEYMU3DM.....\$85.00



Dirt Modified Headers

Forward design for muffler clearance. Fits Behrent, Bicknell, Olsen, TEO, Troyer & other chassis.

Crate Motor Tube Dia. 1 5/8" Up Swept Collector 3x8"

SCH1122BUCM2.....\$249.95



Exhaust Elbows

Used as lower and upper elbow.
3" 13"SCH3013 ...\$23.95



Universal Exhaust Mount

Universal Mount fits 5" or 6" muffler cans. Mounts to BRP 7100 rear nerf bar post. Clamp flips up or down and cradle spins front to back for infinite adjustment. Laser cut steel and powder coated. 2 springs included in kit to retain muffler to cradle. Replacement parts also sold separately. Cradle is BRP 9265 and clamp is BRP 9264. Bolts and seals for rear end are not included***
BRP9263.....\$72.53



Crate Motor Gaskets

For a tight seal, don't forget the gaskets for your Schoenfeld headers. They offer header gaskets made with steel & stainless steel core laminate to provide stability, max torque retention, & excellent heat resistance.

Tube Dia.: 1-5/8" or 1-3/4"....SCH01560.....\$8.00



Header Gaskets

Perforated Steel Core w/anti-stick coating. Fel-Pro Exhaust Header Gasket facing consists of high-density fiber attached to both sides of a perforated steel core; the fiber has great torque retention qualities. These gaskets can even seal slightly warped surfaces and resist blowout/burnout from high-temp exhaust gas. Nonstick coating allows motion without damage, which simplifies gasket removal for servicing.

SBC D-port.....FEL1406.....\$20.69



Complete V8 stud kit with washers and hex or 12-point nuts. In chrome moly or stainless. Priced per set.

Header Bolts

3/8" diameter
Small Block Chevy Black Oxide Hex 3/8" wrench ARP100-1101...\$20.28 ARP100-1201...\$16.03 drilled 3/8" wr ARP100-1103...\$23.90 ARP100-1203...\$25.11



Header Bolts

Grade 8 Header Bolts are heat-treated with black oxide finish. Uses 7/16" hex head for quick installation and removal of headers. Header Bolts. 3/8"-16 x 3/4" hex head bolts for Small, Big Block and 90° V6 Chevy engines, Small Block Ford and other engines where a 3/8"-16 bolt is used. 16 per package
MOR38710...\$10.19



Crate Motor Section

COOLING

JON 1004-AL-DRT
(Cast Iron WP)



Lightweight Low Drag Complete 602/604 Crate Engine Kit.

Includes DIRT Legal Steel Water Pump, Lightweight Aluminum Power Steering Pump and Bracket, Pulleys, Mounting Hardware, Belt, and Spare Belt.

JON1004-AL-DRT\$718.13

JON2041-RA

SBC Radius Tooth Alternator Kit..2041-RA

45 amp, 1-Wire Alt.....JONAL-9101-B-NS\$249.90
24 Tooth Alt. Pulley.....JONAL-9105-24-A\$62.90
32 Tooth Drive Pulley.....JONWP-9104-32\$52.40
Belt Guide.....JONBG-9108-W\$14.60
Radius Tooth Belt.....JON672-10HD\$16.78
Alternator Bracket.....JONAL-9100-CL-B.....\$68.15
Rear Alternator Support.....JONAL-9100-CL-HM ..\$47.15
Mounting Kit.....JONAL-9100-CL-BK\$15.65
Switch.....JONSW-9100-A\$12.48

Use kit JON2040 for V-Belt Setup



Crate SBC Serpentine Pulley Kit

SBC Serpentine Pulley Kit Complete with Alternator and Power Steering Pump and Red Brackets, 17% Reduction. All Pulleys and Belts.....BRP1442.....\$694.84
All Pulleys and Belts (Black).....BRP1442BK...\$694.84

Kit Includes:

Serpentine Pulley

BRP952-2.....\$73.74

Pulley Spacer

BRP953.....\$20.54

Serpentine Belt

BRP949-3.....\$35.05

Power Steering Mount Assembly

BRP268.....\$45.46

Pump and Serpentine Pulley

BRP581.....\$209.49

SBC Alternator Mount

BRP9068.....\$83.70

Serpentine Pulley Water Pump/ 3 Rib Alternator

BRP946.....\$72.90

3 Rib Serpentine Belt

BRP947.....\$24.86

Alternator with Serpentine Pulley

BRPPOW8172-172.....\$211.28



Stage 1 Water Pump

Stock appearing cast iron design, but with improved bearings and impeller.

Short SBC 71-82 Corvette Only, 5.795" Length
STEW13103.....\$88.95



SBC

Crate Engine JON2441-AR-CE WP, Power Steering & Alt Drive

JON2441-AR-CE\$1799.00

Includes:

SBC Drive Mandrel...JONDH-8101-NE-B-2.5.....\$58.82
Crank Pulley Spacer.....JONSP-6103-B-A-3/8.....\$6.53
Belt Guide.....JONBG-6108-C.....\$7.99
Radius Tooth CS Pulley..JONCS-6102-AS-25.....\$58.50
Belt Guide.....JONBG-6108-A.....\$7.00
Bolt & End Cap Kit.....JONBEC-2109-K.....\$13.14

Radius Tooth WP Pulley..JONWP-6104-37S\$87.80
Pulley Mounting Kit.....JONWP-6104-MK\$9.81
Fan Shield.....JONBG-9108-E.....\$13.14

PS Pump w/Alum. Tank..JONPS-9008-AL-AR\$359.90
Radius Tooth PS Pulley..JONPS-6106-B-40\$70.79
Belt Guides.....JONBG-6108-40S\$35.40
PS Bracket w/Hardware..JONPS-8001-SB-R\$85.95
Radius Tooth Belt.....JON640-20HD.....\$32.46



Low Profile

For Northeast Dirt Mod,
Late Model, and IMCA.
Total Height 4.5 Inches.
Fits under low hood design.
Each tank comes with an
o-ring and mounting hardware.



Fits 602 Crate and all
Big Blocks has 1-3/8"
NPT Fitting for rear
cooling line
ART58037C...\$385.00



Molded Hoses

- 4 Ply construction strongest on the market.
- Wire reinforced.
- Part # for easy identification.
- Black and Red in color.

Upper Molded Hose

SBC Black....BRP9345\$77.43
SBC Red.....BRP9345RD..\$77.43

Lower Molded Hose

SBC Black....BRP9344\$93.53
SBC Red.....BRP9344RD..\$93.53



Radiator Hoses

2-ply coolant hose is flexible & adapts to a variety of apps. Abrasion resistant cover will not crack or harden.
1-1/2" Dia, 20" Upper Hose.....ALL30208..\$12.99
1-3/4" Dia, 19" Lower Hose.....ALL30226..\$21.99



Pro-Lite 350 Braided Hose

Inner liner of hi-temp synthetic rubber tube, clean and fast flowing, partial coverage textile inner braid reinforcing. Outer layer of braided nylon provides 350psi pressure capabilities while maintaining durability & flexibility.

size 3"
-10 EAR350310 ..\$34.76



Crate 7mm Pulley Kit

Kit includes alternator belt, mount, and pulley. They do not include the alternator. 35% Reduction.
BRP9274\$597.04

Kit Includes:

7mm Lower Crank Pulley
BRP9270\$83.70
Water Pump Pulley with built in fan spacer
BRP9271\$156.17
Alternator pulley
BRP9273\$52.45
Steel Power Steering Pump w/9272 pulley installed
BRP9288\$209.49
Block Mount Power Steering Pump Bracket
BRP268BK\$45.46
Alternator Mount
BRP9068BK\$83.70
Belt for Crank/Water Pump and Crank/Steering Pump
(3 required)
BRP9286\$30.02
730mm Belt for Water Pump/Alternator (1 required)
BRP9287\$31.35
Hex Drive Adaptor (allows turning motor over w/socket)
BRP9296\$22.25
17" Nylon Lightweight Fan
ALL30094\$19.99



6 Blade Fans

Heavy-duty, 6-blade fans are available in alum or steel versions and can move the volume of air needed to keep expensive race engines cool. Universal bolt pattern with a 5/8" pilot hole.



Diam. Steel Blades

17".....ALL30103\$31.49

Fan Spacer Kits

Alum spacers include reducer bushing, four Allen bolts to secure spacer to water pump and four hex bolts with washers to secure fan to spacer. Note: ALL30180 and ALL30182 include one set of 4 Allen bolts only.

2" Fan Spacer Kit.....ALL30186\$27.99



Fan Spacers

2" Spacer - Red...BRP1012.....\$31.91
2" Spacer - Black..BRP1012BK..\$30.38

Aluminum Oil Inlet Fittings

Aluminum fittings are offered in
-10AN to ease oil line installation.
-10AN x 1/2" NPT, 3.00" Long

ALL90043\$23.99



Stant

Racing Radiator Caps

21-25 psi w/EarsSTAN 10372 ...\$17.95

Crate Motor Section

FUEL DELIVERY

Holley

Mechanical Fuel Pump

170+ GPH pumps
3/4"-16 Inlet & outlet
Needs -8 Port Fitting.
SBC.....HOL12-327-20...\$144.95



PRO/CAM RACING ENGINE COMPONENTS

PRC9351

Mechanical Fuel Pumps

SBC 7 1/2" PSI, 6 Valve
PRC9351.....\$139.95



SBC Cast Fuel Pump - 7 PSI

SBC Steel -10 AN In/Out...CVSPIN-MP-504.....\$189.12
Replaces CATM4891-503D



SBC Steel -8 AN In/Out...CVSPIN-MP-5048...\$180.95
Replaces CATM4891-502D

Steel Fuel Pump Fittings

-8.....CVSPIN-MP-386.....\$15.86
-10.....CVSPIN-MP-385.....\$15.86

MOROSO

LW Fuel Pump Push Rods

Lightweight design with hardened ends reduces reciprocating mass to prevent pump arm float and subsequent fuel starvation.

Lightweight Fuel Pump Push Rod. SBC and BBC
MOR65750.....\$22.34



Pipe Thread to AN Adapters



Pipe Thread to AN Adapters Straight

size	NPT	aluminum straight
-8	3/8	EARAT981608.....\$5.57
-8	1/2	EARAT981688.....\$6.50
-10	3/8	EARAT981611.....\$6.54
-10	1/2	EARAT981610.....\$7.48



Inner liner of hi-temp synthetic rubber tube, clean and fast flowing, partial coverage textile inner braid reinforcing. Outer layer of braided nylon provides 350psi pressure capabilities while maintaining durability and flexibility.

Pro-Lite 350 Braided Hose

size 3'
-8 EAR350308 ..\$31.60



Ano-Tuff Swivel-Seal Hose Ends

size straight
-8 EARAT800108 \$11.57



size 45°
-8 EARAT804608 \$26.58



size 90°
-8 EARAT809108 \$29.50



Ultra HP Carbs

Making these carbs 38% lighter, increase the fuel capacity by 20% and add 30 other new features! They're available in our all-new Hard Core Gray hard coat anodized finish with Black billet for superior corrosion protection.

- 97% alum construction
- (For superior corrosion protection)
- 10 fuel bowl & base plate features
- 6 new metering block features
- 5 new main body features

Alum. Ultra HP - Hard Core Gray
650 cfm..HOL0-80802HBX..\$823.95

Holley

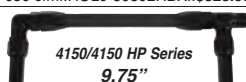

Single Inlet Ano-Tuff Pro-Lite 350 Hose

-6 AN EARAT104195.....\$99.47
-8 AN EARAT104295.....\$114.95

Carburetor, Power Steering, Fuel Pumps, Fuel Injection

-8 AN Male to 3/4"-16 Male
EARAT991958...\$10.48

Holley HP SERIES 4150 HP Carb

Contoured Venturi Inlet. High Flow Metering Blocks. 4 Corner Idle System. Center Hung Dominator Style Fuel Bowls. Spun-in Down Leg Boosters. Power Valve Blow-out Protection. 100% Wet Flow Tested and Calibrated.
650 cfm....HOL0-80541-1.....\$672.95

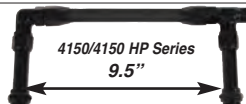

Single Inlet Ano-Tuff Pro-Lite 350 Hose

-8 AN EARAT101295.....\$115.95

500 CFM

Ultra XP 2BBL

All aluminum construction for nearly 50% weight savings over zinc version. Tumble polished alum w/Black billet alum metering block and base plate. No choke tower for unobstructed airflow. Air bleeds moved outward to allow a smoother transition of airflow....HOL0-4412BKX...\$542.95

Phenolic Carburetor Spacer

Advanced plastic and phenolic compounds are specially formulated to reduce heat conductivity 10 times greater than alum. Reducing fuel temp inside the carburetor results in a denser, more powerful fuel charge to the manifold. 1" Spacer. Fits Holley 4150/4160 bolt pattern, open plenum design
MOR64940.....\$37.19

Cast Aluminum Carburetor Spacers

Open plenum alum carb spacers increase plenum volume for high RPM power. 4 hole carb spacers increase mixture velocity for more midrange torque. 1" Spacer. Fits Holley 4150/4160 bolt pattern, open plenum design....MOR64980...\$51.98

Open Plenum 4150 Spacers

These spacers are machined to a minimum material not only to reduce weight, but also to reduce conductivity of heat from manifold to carb.
WM000010.....1".....\$104.40

Carb Spacer 1/4" Thick, Billet Alum.

BRP9092...\$27.84



ARP

Carburetor Stud Kits

The best way to make carbs stay perfectly sealed to the intake manifold is through the use of ARP's carb studs, which feature J-form threads to resist loosening from vibration.

Quantity: 4 • Size: 5/16
Applications.....O.A.L.....Black Oxide
1" spacer.....2.700ARP200-2402...\$17.96



11" Air Filters Chrome

The perfect application for when space is a premium, yet high performance is required. Base is available in 3 flange sizes and various heights to fit a wide variety of applications.

Neck Flange: 5-1/8"
Element Height: 5"



Complete.....Total
Element.....Assy.....Height
K&N-3680..\$73.99...K&N60-1190..\$122.99.....6.00"

Air Filter Gaskets

Designed to fit under the air cleaner for most carbs. They will help prevent unfiltered air from entering your engine.

Holley, Carter, Q-Jet..FEL2104..\$8.68



Aluminum Longacre Air Cleaner Stud Kit

Lightweight alum. Includes alum stud, thumb screw and air cleaner lid mount. Jam nut and mounting nut go under air cleaner lid so you can tighten the thumb screw without distorting the top. Built-in rubber seal keeps dust out of your engine.

5/16" Carb Thread.....LON32750\$37.28



MOROSO

Carbureted Mounted 2300/4100 Series

The answer to your throttle return spring linkage problems if you're running a 2300/2305 series two-barrel or 4150/4160 series four-barrel Holley carb. Designed & built rugged enough for competition, yet it's polished chrome finish is suitable for the finest show car. Includes one set of heavy and one set of light springs.
MOR64927\$26.22



Bullet Nose Carb Stud Kits

"Bullet Nose" studs are rounded on one end, making it easy to start nuts. Kits include 4 studs, hardened flat washers and jam nuts.

Fits carbs with 1/2" thick flange base with a 1" spacer or w/ 1 or 2, 1/2" spacers, 5/16"-18 and 24 x 2-1/2" long.
MOR37960\$8.42



Carb Base Gaskets for Holleys

4150/4777 Open Plenum
FEL1900.....\$5.23



Fuel Pump Gasket

FELP70573.....\$0.39

Fuel Pump Plate Gasket

FELP70576.....\$0.53



SBC Fuel Pump Plate (Aluminum)

BRP356...\$13.18



Crate Motor Section

OIL SYSTEMS



SBC Oil Filter Adapter

Stock replacement adapter bolts to the engine block and accepts oil filter.

Oil Filter Adapter.....ALL92000 ..\$12.39
Two Fasteners for Oil Filter Adapter
ALL92001 ..\$5.99



MOROSO Oil Bypass Eliminator Chevy

Designed to eliminate the oil bypass found on Chevy engines. A stock type spin-on oil filter can be used with this part installed.

MOR23775...\$36.11



MOROSO Oil Filter Adapters

Sandwich Adapter allows use with external plumbing, (coolers, dry sump pump or accumulator) while keeping filter in stock location.

For use w/remote coolersMOR23692...\$91.78



Pipe Thread to AN Adapters

Pipe Thread to AN Adapters Straight

size NPT aluminum straight
-12 1/2 EARAT981613.....\$10.95



#4 Straight to 1/8 NPT Oil Pressure Fitting

EAR968804...\$10.00



Peterson Oil Pressure Gauge Fittings

They get the oil pressure gauge line connection up where it is more accessible. Fitting is 1/8" NPT on engine side and -4 AN for gauge connection.

Straight FittingPET15-1041\$14.62



Synthetic Oils

XP3 Viscosity typical of SAE 10W-30

Provides outstanding high temp and high shear protection. Utilizes select synthetic base oils for increased durability at high temps. Formulated with proprietary anti-wear and friction reducing additives to fight valve train wear and increase horsepower. Ideal for crate, spec and custom built engines with clearances under .0027. Compatible with methanol and high octane race fuels.

JGR003061 Quart\$14.99



XP9 Viscosity typical of SAE 10W-40

Provides increased high temp and high shear protection for wet sump and high compression applications. Utilizes select synthetic base oils for increased durability at high temps. Compatible with methanol and high octane race fuels. Formulated with proprietary anti-wear and friction reducing additives to fight valve train wear and increase hp. Ideal for high output steel block engines.

JGR032061 Quart\$14.99



BR Break-In Oil

Used to break-in and dyno all their engines, this petroleum oil provides the highest levels of Zinc and Phosphorus for flat-tappet engines. The additive package promotes ring seal and provides maximum protection available for cams and lifters during initial break-in. Good for 2 hours dyno time and requires no additional additives.

15w50 (Quart)JGR00106...\$7.99



MOROSO Oil Filters

Chevy, 13/16" -16 UNF thread, long design (5-1/4" high), burst strength: 350 psi (max.)

MOR22460\$14.18



MOROSO Oil Filters

They are just for performance and racing use. The spin-on filters can trap very small micron-sized particles that cause most engine wear. All filters have an anti-drainback valve with a maximum flow rate.

1 quart Chevy...FRAHP-4....\$10.95



MOROSO Oil Filters

WIX has the low down on dirt and their Racing oil filters are ready to trap more dirt -45% more! Your engine needs lots of clean oil to get you across the finish line first and WIX has spent years of researching the effects of racing on filters and decades of manufacturing the best to gain the distinction of being the only filters officially licensed by NASCAR.

Flow Rate GPM....28

Thread....Filter....Filter...BypassAnti-Drain Size.....Height..OD Valve Setting..Back Valve
13/16-16..5.17.....3.6None.....Yes
1 Quart.....WIX51061R....\$11.19



K&N Oil Filters

K&N's premium wrench-off line of auto and marine canister oil filters were developed to meet the high perf. demands of race applications. They have rapidly become popular for their canister strength and durability. These canister style oil filters are designed to handle higher oil pressures than a standard oil filter and can be used with the latest synthetic motor oils. Most of these premium auto & marine canister oil filters come with a 1 inch welded nut on the top that makes removal easy. Premium canister oil filters for car, truck, and SUV applications. Exposed nut designed for easy removal (where applicable), on, high flow rates, & outstanding oil filtration. Traps 99% of harmful contaminants. Can be used with the latest synthetic motor oils.

1 quart Chevy...K&NHP-3002...\$12.09



IGNITION



Ultra 40 Spark Plug Wires The Most Powerful Wire Ever!

Highest spark energy transfer! Highest EMI/RFI suppression! Highest horsepower gain! Nickel copper conductor surrounds layers of ferrite impregnated core and Kevlar, protected by an extra thick EPDM layer and an 8.65 mm silicone jacket. No more powerful wire made.

Sleeved under header

SBC 90° HEI
MOR73607.....\$147.94 ea



8.5mm Super Conductor Wire Sets

The MSD Race Tailored Heli-Core and 8.5mm Super Conductor Wire Sets are designed specifically to fit race engines equipped with headers or an MSD Distributor.

8 cyl All SBC w/HEI style Dist Cap
MSD35599.....\$94.32



Circle Track RPM Control Digital Soft-Touch HEI Rev Limiter

Fully digital operation allows for accurate rev limiting. Rotary dials eliminate the need for plug-in RPM modules. Easy installation to any HEI distributor with plug-in wiring and connectors. Epoxy filled for endure extreme racing conditions and eliminate potential tampering with circuitry.

MSD8727CT...\$175.95



Racing Spark Plugs

HOT



COLD

14mm

3/4" Reach

5/8" Hex

Taper Seat

Projected Tip

Fits Many SBC

Crate Engines

V-Power Resistor Spark Plug

14mm x .708" Reach

5/8" Hex

Projected

Tapered seat



Plug Type

NGKTR5.....\$1.99

Plug Type

NGKTR6.....\$1.99



Blue Max Spiral Core Pre-Made Sets

8mm silicone. Insulated sleeve runs full length. Shrink tube sealed boots, and numbered ID tags. Race wire kits do not include coil wires.

SBC - HEI Type Terminals

Under Headers
MOR72407.....\$130.07



IMPACT Nitro

A self contained air filtration system that functions solo to purify inhaled air, or in conjunction with onboard bottle air systems. SNELL & SFI/FIA approved. Sizes: S-XL. Std colors are Silver, Flat/Gloss Black, white, and carbon fiber are available. SA2015.

IMP18015.....**\$1,199.00**
Carbon Fiber.**\$1,899.00**



Tear-Offs
ULT1215C
RAC10231C



SFI 15 & SFI-20 Team Drag 2-Piece Firesuit

SFI Foundation's 3.2A/15 Specification. Fire-retardant outer layer with cool, comfortable proprietary multi-layer inner. 360 degree full-floating arm gussets. Comfortable ribbed arm and ankle cuffs (will tuck into your race shoes/boots) for a tight seal and fit. Front patch pants pockets. Available in Black with silver piping.

IMP29300(size)	SFI-15 Jacket..	\$629.50	SFI 15
IMP29400(size)	SFI-15 Pants...	\$599.00	
IMP29600(size)	SFI-20 Jacket..	\$678.00	SFI-20
IMP29700(size)	SFI-20 Pants...	\$651.00	

Redlined Drag Glove SFI 3.3/20 Certified

Innovation, technology and design have come together to create Impact's newest drag glove offering both comfort and performance. Designed specifically for the drag-strip and featuring superior fire protection with its SFI rating of 3.3/20 and a TPP of over 100, the Impact Redline glove offers an anatomically correct pre-formed shape and suede insert panels on the palm and fingers allow maximum comfort and grip. The zig-zag elastic gauntlet ensures the gloves stay comfortably in place over the fire suit. Adult Sizes S-XXL. Colors: Black Only. IMP37500.....**\$225.00**



Drag/Nitro Over-Boot

Our Impact Top Fuel/Top Alcohol Over-Boot, which fits securely over Impact race shoes, is made with Nomex inner and outer and overlap hook and loop extra-length cover. Black only. IMP4900.....**\$249.00**



5-Point Camlock Seat Belts

Drag Racing "V" type (covered in Nomex)
SIM29116.....**\$279.95**



10' Sky Jacker Drag Chute

Handmade Crossform design delivers reliable and durable performance for cars up to 200 mph. Complete with nylon pack and pilot chute. Colors: Black, Red, or Blue. SIM42020(color)..**\$429.95**



TH400 Cast Aluminum Deep Pans

One of the best investments you can make to assure longevity of your automatic transmission is a cast aluminum deep pan. Designed with cooling fins to dissipate heat faster, these pans also provide additional strength and rigidity to the transmission case. No modifications are necessary to the stock dipstick and the pan includes magnetic drain plug, fluid pickup extension, filter, pan gasket and new rail bolts and washers.



Holds 2 extra quarts
TCI228000.....**\$156.91**

TH350 Cast Alum Deep Pan

One of the best investments you can make to assure longevity of your automatic transmission is a cast aluminum deep pan. Designed with cooling fins to dissipate heat faster, these pans also provide additional strength and rigidity to the transmission case. No modifications are necessary to the stock dipstick and the pan includes magnetic drain plug, fluid pickup extension, filter, pan gasket and new rail bolts and washers. Holds 2 extra quarts
TCI328000.....**\$168.58**



Powerglide Flame Die Cast Aluminum Deep Pan

The engineers at TCI have created a transmission fluid pan unlike any other. The TCI Die Cast Deep Aluminum Pan for Powerglide Transmissions offers revolutionary features that every high performance automotive enthusiast will appreciate. This deep pan is the first of its kind. Inside, the pan incorporates heat dissipating "inverted-dimples" that increase the surface area inside the pan. These unique "heat suckers" pull heat toward the exterior of the pan - ultimately lowering the temperature of the fluid. On the outside of the pan, exterior fins are slightly angled to create a funnel effect which increases the air speed across the surface. Finally, the pans' exterior is black powder coated to absorb heat from the interior to further lower operating temps.
TCI528220.....**\$165.92**

Dipsticks

Each dipstick features a locking stick that satisfies sanctioning bodies' racing rules.

TH350 Chevy Dipstick

Full Length, Locking-Style TH350 Chevy Stick Race or Street Use (Gold Dichromate)
TCI743861.....**\$55.22**

TH400 Chevy Dipstick

Full Length, Locking-Style TH400 Chevy Stick Race or Street Use (Gold Dichromate)
TCI743802.....**\$58.45**

Powerglide Dipstick

Full Length, Locking-Style Stick Race or Street Use (Clear Zinc)
TCI743800.....**\$38.41**



Heavy-Duty Micro Switch

Large Button Micro Switch with Cord
Sealed switch attached to spiral cord that stretches 7 feet
TCI388500.....**\$81.80**



Outlaw Shifter

It features rugged construction and is perfectly suited for competition use including compliance with NHRA/IHRA legal reverse lock out regulations. In addition, TCI's Outlaw Shifter features a Park/Neutral safety switch along with provisions for a reverse light system. TCI Outlaw Shifter includes 5-feet of heavy-duty shift cable and all the hardware required for installation. Optional 3-speed reverse pattern and 4-speed forward pattern gate plates are also available. Note: Ford AOD requires a 618016 installation kit.



w/cover Powerglide.....TCI611323..**\$357.11**
w/cover 3 Speed Forward.TCI616331..**\$371.07**

Transmission Safety Shield

Made from 6061-t6 aluminum, TCI's transmission shield is lightweight and offers excellent protection in the event of a drum explosion. Certified SFI 4.1.

Powerglide.....TCI970000..**\$131.80**
TH400.....TCI980000..**\$189.53**



MOROSO

Universal Anti Roll Kits

Brake line locks are used in Drag Racing to lock the front wheels and hold the car in the water box for the burnout, or to prevent creeping in the lights. Has a check valve which allows you to pump up the brakes while actuated. Will work in applications with ABS.



Univ Anti Roll Kit.....MOR44050..**\$122.61**
Univ Anti Roll Kit Enhanced...MOR44052..**\$183.04**



Racing Flexplates

Chevy Flexplates are .035" thicker than stock and the ring gear is welded to both sides for added strength. Dual GM bolt patterns are sized for stock 3/8" bolts but can easily be drilled to 7/16" for added strength. SFI 29.1 approved.



Chevy - Forged Flexplate (Stock to mild performance)

Internal Dual Bolt Pattern 168T...TCI399273..**\$96.36**
Ext 400, Dual Bolt Pattern 168T...TCI399373..**\$96.36**
External Dual Bolt Pattern, 168T...TCI399473..**\$96.36**
Internal Small Bolt Pattern 153T...TCI399573..**\$109.96**
External Dual Bolt Pattern, 168T
Only for 1 Pc Rear Side Engines TCI399773..**\$118.04**

Chevy - Machined Flexplate (Moderate to serious performance)

LS1 Chevy Flexplate.....TCI399753..**\$297.26**
LS1 to 4L80e Trans Flexplate.....TCI399754..**\$297.26**

Ford - Machined Flexplate (Moderate to serious performance)

289-351C, 351M-400M, Internal balanced, for racing applications only.....TCI529632..**\$286.68**

MEZIERE

SFI Spec 29.1 True Billet Flexplates

Total Weight.....6.3 lbs.
Counter Bal Wt...Neutral
Converter Pat.....3 on 10.75 and 3 on 11.5

A	..14.14
B	..0.450
C	..0.170
D	..2.49



Tooth Count 168 • Pitch 12...MEZFP300.....**\$397.71**
Tooth Count 139 • Pitch 10...MEZFP300.....**\$397.71**
Bolt Kit.....MEZFP437625..**\$17.75**

Synthetic Oils

**JOE SIBBS
DRIVEN
RACING OIL**

XP0 Viscosity typical of SAE 0W.....JGR00406.....1 Quart.....**\$17.99**
Utilizes ultra-low viscosity synthetic base oils for maximum horsepower during qualifying. Formulated with proprietary anti-wear and friction reducing additives to fight valve train wear and increase horsepower. Ideal for low temperature drag race applications.

XP1 Viscosity typical of SAE 5W-20.....JGR00006.....1 Quart.....**\$17.99**
Proven to handle 500 miles of competition at over 9500 RPM, XP1 utilizes multiple synthetic base oils for increased durability under higher loads. Formulated with proprietary anti-wear and friction reducing additives to fight valve train wear and increase horsepower. Ideal for high RPM and high output engines with tight clearances. Compatible with methanol and high octane race fuels.

XP2 Viscosity typical of SAE 0W-20.....JGR00206.....1 Quart.....**\$17.99**
Utilizes low viscosity synthetic base oils for increased horsepower without decreased durability. Formulated with proprietary anti-wear and friction reducing additives to fight valve train wear and increase horsepower. Ideal for restricted airflow applications and engines with tight clearances. Compatible with methanol and high octane race fuels.

XP3 Viscosity typical of SAE 10W-30.....JGR00306.....1 Quart.....**\$14.99**
Provides outstanding high temp and high shear protection. Utilizes select synthetic base oils for increased durability at high temps. Formulated with proprietary anti-wear and friction reducing additives to fight valve train wear and increase horsepower. Ideal for crate, spec and custom built engines with clearances under .0027. Compatible with methanol and high octane race fuels.

XP6 Viscosity typical of SAE 15W-50.....JGR01006.....1 Quart.....**\$14.99**
Provides excellent bearing oil film thickness for aluminum blocks and looser clearance engines. Utilizes select synthetic base oils for increased durability at high operating temp. Recommended for methanol fueled engines. Formulated with proprietary anti-wear and friction reducing additives to fight valve train wear and increase horsepower. Compatible with high octane race fuels.

XP9 Viscosity typical of SAE 10W-40.....JGR03206.....1 Quart.....**\$14.99**
Provides increased high temp and high shear protection for wet sump and high compression applications. Utilizes select synthetic base oils for increased durability at high temps. Compatible with methanol and high octane race fuels. Formulated with proprietary anti-wear and friction reducing additives to fight valve train wear and increase hp. Ideal for high output steel block engines.

XP10 Viscosity typical of SAE 0W-10.....JGR03306.....1 Quart.....**\$17.99**
Utilizes multiple low viscosity synthetic base oils to fine tune for increased hp and improved ring seal. Ideal for wet sump drag race engines and restricted airflow engines with tight clearances. Formulated with proprietary anti-wear and friction reducing additives to fight valve train wear and increase hp.

Semi Synthetic Racing Oils

XP5 Viscosity typical of SAE 20W-50.

A semi-synthetic based on our original formula race oil, XP5 provides excellent roller lifter and roller rocker arm protection. XP5 delivers improved high temperature shear and oxidation stability compared to mineral oil without the higher cost of a full synthetic. For use in high compression engines.

JGR00906.....1 Quart.....**\$9.71**

XP7 Viscosity typical of SAE 10W-40.

A semi-synthetic 10W-40 racing oil based on our proven XP5 racing oil. Ideal for desert and off-road engines, IMCA modified engines, spec engines, flat tappet camshafts and hydraulic lifter engines. Designed for clearances under .0030.

JGR01706.....1 Quart.....**\$9.71**

Petroleum Oils

XP4 Viscosity typical of SAE 15W-50.

High Zinc, Petroleum formula racing oil, XP4 offers low cost protection for racers who want to use non-synthetic oil. Excellent protection for dirt and nitrous racers who need to change their oil frequently. Recommended applications: big block, flat tappet camshaft, nitrous and alcohol fueled drag engines.

JGR00506.....1 Quart.....**\$7.99**

XP8 Viscosity typical of SAE 5W-30.

Excellent low cost drag racing oil. A high Zinc, Petroleum formula racing oil, XP8 offers low cost protection for racers who want to use non-synthetic oil. Recommended apps: small block, flat tappet camshaft engines & tight clearance nitrous engines (under .0027).

JGR01906.....1 Quart.....**\$7.99**

Qualifying Gear Oils.....1 Qt..JGR01130..\$17.99

An ultra-lightweight gear oil developed specifically for stock car qualifying. Provides race proven durability in open wheel competition. Proven durability in spiral bevel gear sets. Designed to reduce parasitic drag for qualifying runs when rear gear and trans temps are below 200F.

Synthetic Gear Oil.....1 Qt..JGR00630..\$17.99 • 5 Gal. Pail..JGR00617..\$350.02

This unique gear oil reduces operating temps by up to 15° compared to other brands. Viscosity typical of SAE 75W-110.

Super Spdy Gear Oil.....1 Qt..JGR00830..\$17.99

Lightweight, 100% synthetic gear oil provides race proven durability and power gains from reduced friction and parasitic drag.

SR50 Conventional Race Oil

Ideal for race engines requiring a 20W50 weight motor oil, SR50 provides consistent protection for flat tappet engines and prevents lifter skidding in aggressive roller cam valve trains using both needle and bushing lifters. It is not recommended in engines with stamped steel rockers; instead, use Driven Racing Oil's XP9 or XP6 for optimal durability.

20w50 (Quart).....JGR05206...**\$7.99**

Race Wax

It leaves a smooth, glossy finish that helps shed tire rubber and dirt. Perfect product for race cars with full decal wraps and fiberglass body cars. This makes clean up quick and easy without damaging the decals, paint, or windows.

JGR50060.....24 oz. Bottle.....**\$8.26**

Power Steering Fluid

A fully synthetic formula power steering fluid. Offers high temp foam resistance.

1 Quart.....JGR01306.....**\$11.49**

Manual Trans Fluid

A fully synthetic fluid specially designed to meet the specific needs of an oval track/drag racing manual trans.

1 Quart.....JGR01206.....**\$8.99**

High Viscosity Lubricant

It provides a tenacious yet fluid film to protect reciprocating and rotating components during assembly and initial break-in. This non-foaming product mixes with the break-in oil and extends film thickness during the critical break-in process.

JGR50050.....8 oz. Bottle...**\$8.99**

Coolant System Protector

Impurities in well water can cause rust and corrosion inside the radiator, water pump and cylinder heads, and this can lead to a loss of cooling efficiency. It stops the adverse effect of hard water better than the leading brand of coolant additives.

1 Quart.....JGR50030.....**\$8.99**

BR Break-In Oil

Used to break-in and dyno all their engines, this petroleum oil provides the highest levels of Zinc and Phosphorus for flat-tappet engines. The additive package promotes ring seal & provides max protection available for cams and lifters during initial break-in. Good for 2 hours dyno time & requires no additional additives.

15w50 (Quart).....JGR00106...**\$7.99**

5w30 (Quart).....JGR01806...**\$7.99**

Hot Rod HR High Perf. Oils

HR-1: Perfect for BB muscle cars, blown street rods, and high temp protection. Great loose bearing clearances.

Conventional 15W-50.....JGR02106..**\$7.99**

HR-2: Great for SB engines and "crate" motors. 10W Multi-Grade formula provides great start-up protection.

Conventional 10W-30.....JGR02006..**\$7.99**

SYNTHETIC FORMULA: They provides improved cold-start protection compared to mineral oils.

HR-3: Great protection for blown marine engines and air cooled engines.

Synthetic 15W-50.....JGR01606..**\$9.99**

HR-4: The ultimate in street/strip protection - Excellent start-up protection and high temp stability of a synthetic.

Synthetic 10W-30.....JGR01506..**\$9.99**

Assembly Grease

Unique formula completely dissolves in oil leaving no residue. Used to pre-lube cams & lifters. Application to ring land prevents micro welding during initial engine break-in. Combined with JGR BR, it provides proven protection during break-in.

JGR00728...**\$2.99**

Automotive Degreaser

Professional strength formula foams away dirt, grease, and oil from all automotive parts and surfaces. Safe for use on any washable parts including rubber and plastic. Use for any degreasing need in your shop.

JGR50010...**\$5.39**

Brake and Parts Cleaner

Quickly removes brake fluid, grease, oil and other contaminants from brake lining and drums. Dries Fast. Leaves no residue. Non-Chlorinated. Excellent general parts cleaner.

JGR50020...**\$4.49**

Speed Shield

It is designed as a protectant that sheds dirt, dust, and mud, while providing a glossy, protective film for a variety of surfaces. After pressure washing the vehicle, spraying it down with Speed Shield will rinse away the smaller remaining dirt particles and leave a shine that isn't wet or oily. Ideal for off-road, power-sports, and dirt racing vehicles, this fast-drying, water-resistant product works great on plastic, paint, decals, and fiberglass.

JGR50070...**\$8.26**

Speed Lube

It is a spray lubricant for chains, linkages, Heim joints, and bearings. It features a variety of adhesion and anti-wear properties and is designed for extended intervals between applications. Speed Lube comes in a convenient aerosol spray can and is specially formulated to provide lubrication and protection from corrosion in hostile environments to bike chains and other parts.

JGR50090...**\$6.99**

Extreme Pressure Chassis Grease

This grease with excellent load carrying ability. Designed for High Temps & High Loads, JGR EPC provides exceptional mech stability in an NLGI #2 grease.

400 grams Cartridge..JGR70030...**\$15.99**

Spline Grease

Engineered for race apps with sliding spline teeth operating at high temps & RPM's. It utilizes a high viscosity synthetic base, proprietary anti-wear additives & a Polyurea thickener that is specially developed to extend durability.

JGR70070.....1/2 lb Tub.....**\$49.99**

Carb Defender-Ethanol Fuel Additive

Designed for carbureted classic and perf vehicles, this concentrated additive prevents costly repairs and poor perf resulting from the use of corrosive ethanol-blended pump gas or flex fuels.

JGR70040.....4.5 oz. bottle.....**\$9.49**

Carb Defender Concentrate Fuel Additive

For carb race engines that use Methanol, E85 or Oxygenated race fuel, Driven's Carb Defender Concentrate prevents corrosion and deposits in the fuel system and intake tract.

• Concentrate Treats 55 Gallons
JGR70044.....6 oz. bottle.....**\$14.99**



Hot Lap

Absolutely Undetectable!

Tires run cool. Aerosol works from the inside out. For races lasting 200 laps (based on 1/2 mile tracks) Tire Prep controls heat in racing tires, helps them last 30-50% longer, stay consistent during the race, improves cornering speeds, decreases lap times, can soften tires (which in some cases is desirable), oftentimes not allowed to be used at tracks. The guy pitted next to you is using it.

16 oz.....PROB7016TS\$25.47
GallonPROB7000TS\$120.95



Hot Lap II

Absolutely Undetectable!

Tires run cooler, last longer, grip more. Quicker application than the original, lasts 25 or so laps per application. Tire Prep - controls heat in racing tires, helps them last 30-50% longer, stay consistent during the race, improves cornering speeds, decreases lap times, can soften tires (which in some cases is desirable), oftentimes not allowed to be used at tracks. Gallon.....PROB6000TS2W..\$54.95



Hot Lap Victory Lane

Super quick for 50 laps. Works on asphalt or dirt. Excellent on short tracks. One gallon treats tires for about 4 racing week-ends. Tire Prep - controls heat in racing tires, helps them last 30-50% longer, stay consistent during the race, improves cornering speeds, decreases lap times, can soften tires (which in some cases is desirable), oftentimes not allowed to be used at tracks. Detectable. Gallon PROB5000....\$75.95



Hot Lap 3

Inside Tire Prep. Works on asphalt or dirt. Traction Treatment. Reduces Laptime 2-5 tenths. Tire Prep - Used to soften tires, is not suitable for application on the outside. Detectable.

30 fl. oz...PROB3030...\$28.00

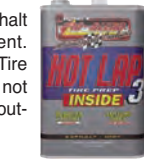

Hot Lap Pro Bite

Dramatically Increases Tire Grip. It is for slick tracks. It can be applied during the week. Hand wiped or rolled. Apply 6 coats (total) Tuesday thru Thursday or roll for 30 minutes on Wednesday. Tire Prep - Used as a topcoat over other Hot Lap tire treatment products. Increases forward and side "bite".

30 fl. oz.....PROB8000\$18.95
GallonPROB8000GL....\$71.95



Drag Racing Tire Treatment

Drag racing tire treatments improves 60 foot times. Reduces E.T.'s by up to 2 tenths, requiring up to 50 percent less burnout time. Helps tires to run much cooler and last up to 40 percent longer.

1 GallonPROB6070.....\$71.43



Racing Tire Cleaner

Cleans surface. Opens pores. Prepares tires for Hot Lap Treatment. It removes the mold release from new tires + cleans any foreign material off used tires + opens the pores of the tire to better accept tire prep. Also if used right before a race, helps tires "fire off" faster (meaning, get up to ideal temp)

1 Quart
PROB7050...\$22.00



40 Below Coolant

Reduces water temperature up to 40 degrees. Creates instant water cool down between rounds in drag cars. Add to radiator. 2 cans provide better results.

PROB4032\$19.95



Undetectable Fuel Additive

Add up to 40 confidential horsepower. Add 1 gallon of CTX-2 to 4 gallons of gas. 1 Gallon Can.

PROB1650...\$112.88



Pro-Tuff Gear Lube Treatment

For Severe Duty applications in rear ends, std transmissions, transaxles, and gear boxes. Its added to rear ends, manual trans, outdrives (although we have a marine version, just cleverly relabeled Marine Gear Lube) reduces heat by up to 50 degrees, eliminates wear, eliminates dry starts, absorbs shock and loading (as in pulling a trailer or a hard start)

PROB8398...\$29.74



Lubricates Entire Fuel System

Blends with alcohol or nitro methane to lubricate the entire fuel system. Add 16 oz. to 50 gallons. 16 oz. containers. Alcohol Fuel Lube (16 oz.)

PROB8400...\$24.33



AP Racing PRF Racing Brake Fluid

Developed for extreme, high temp racing conditions (dry boiling point of 608 degrees F). Exceeds DOT 4 spec. Sold in 16.9 oz. bottle.

ALL78116\$29.99



AP 600 Hi-Temp Racing Brake Fluid

Designed for extreme, high temp racing conditions with a dry boiling point in excess of 572 degs Fahrenheit. Exceeds DOT 3 stds. 1 pint container.

ALL78108\$23.99



Castrol SRF Brake Fluid

Castrol SRF brake fluid has a wet boiling point of 518 deg. F (270 deg. C) which exceeds DOT 3 and 4 standards. Do not mix Castrol SRF and other brake fluids, as this will reduce the benefits of Castrol SRF. Sold in 1 liter containers (33.8 ozs.)

ALL78115\$79.99



Compressor Cool

Especially effective in high heat, high stress environments. Solves water and moisture problems. Immediate, significant noise reduction. Reduces condensation up to 85%. Cools compressor oil up to 52 degrees. Reduces oil foaming up to 80%. Increases lubricity and film strength. Reduces friction, heat and metal wear. Inhibits rust and corrosion. Add 2% to 10% by volume to compressor oil initially. Add an additional 2% to 7% every 700 hours of operation. Will not drain out during oil changes. 6 per case.

PROB1730\$32.36



Oil Treatment

Add to severe duty, high stress and performance engines. Cools oil up to 57 degrees. Eliminates oil starvation, bearing failure, piston scuffing, galling, blueing, metal transfer, valve train drag and foaming. Eliminates condensation in gas and alcohol engines. A must for all Circle, Drag, Blown, Turbo, Nitrous, Pro Street and Marine applications.

PROB1600\$26.78

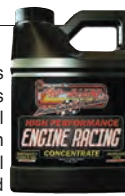

Performance Engine Assembly Lube

Blended for all automotive and industrial applications. Eliminates galling, blueing, metal transfer and oil starvation during break-in. Consistency of warm honey. Dramatic cam and valve train life guaranteed. Not a moly paste.

4 oz....PROB4040\$8.05

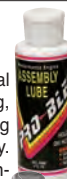

Transmission Fuel Additive

Firm up shifts and stops excessive wear. Great for towing or performance use. Blended for all automotive and industrial apps. Eliminates galling, blueing, metal transfer and oil starvation during break-in. Consistency of warm honey. Dramatic cam and valve train life guaranteed. Not a moly paste. Trans Fluid Additive - cools transmission fluid by 50 degrees, eliminates wear and friction, doubles the life of lubricated parts, eliminates hard shifts.

PROB4012\$17.76



Last Minute Treatment

Designed for racers that get their tires at the last minute. Works on asphalt or dirt. Undetectable.

1 Quart...PROB7032QL...\$31.38



570 Hi-Temp Brake Fluid



Wilwood's specially formulated Hi-Temp[®] 570 Racing Brake Fluid has a minimum 570[°] F. dry boiling point of to withstand the severe heat requirements of automotive racing. Hi-Temp[®] 570's low viscosity allows easy bleeding of your brake system, eliminating aeration of the brake fluid caused by foaming due to excessive pumping of the pedal.

PintWIL290-0632..\$9.96
Case of 24WIL290-0633..\$142.95



Super Hi-Temp EXP600 Plus Brake Fluid

It has been specially formulated for racing apps where brake systems consistently operate at very high temps. In addition to guarding against vapor lock, it maintains its viscosity and lubricity under extreme temps for maintaining brake system reliability and performance.

Pint.....WIL290-6209..\$18.75
Case of 20WIL290-6210..\$329.69





CTS Tire Softener

Chemically treats and softens race tires to increase traction. Sniffer-proof treatment makes old tires soft again. 1 gallon container. CTS Sniff-Proof Softener. ALL78104.....\$38.99



Competitive Edge Tire Treatment

Chemically treats & softens race tires to increase traction without making tires greasy. Apply race day or night before on new or old tires, can be used on the inside or outside. 1 gallon container treats 4 to 6 tires. ALL78105.....\$51.99



Track Claw Tire Strengtheners

Strengthens the rubber and will work on all tires. Undetectable. Reduces lap times 2-3 tenths. One gallon container

180°-220° F Tire Temps
ALL78110.....\$67.99

Up to 150° F Tire Temps
ALL78111.....\$67.99



Oil Reaube w/Moly

Semi-Synthetic 80-90-140 with moly 1 gallon WIN1730....\$45.95



Mud-X Concentrate

Mix concentrate with up to 10 quarts of water to produce a coating that prevents mud, dirt, oil, rubber and exhaust residue from sticking to body panels. Safe for metal, plastic, rubber, and painted surfaces. 1 quart. ALL78230.....\$8.99



DOT 4 Brake Fluid

Designed to lubricate and protect critical brake system componentry while providing reliable stopping power. Anti-vapor lock formulation maintains responsiveness and performance by fighting both water contamination and vaporization. Advanced chemistry resists corrosion, oxidation and is compatible with SBR, EPDM and natural rubbers.



Exceeds the requirements of US FMVSS 116 DOT 3 & DOT 4, SAE J1703, SAE J1704 and ISO 4925 (Classes 3 & 4). DOT-4 - 16.9 oz Bottle.....MAX80-86916.....\$6.95

Exceeds the requirements of US FMVSS 116 DOT 3 & DOT 4, SAE J1703 and SAE J1704. 16.9oz Bottle.....MAX80-87916.....\$16.95

DOT 5 and DOT 5.1 Brake Fluid Silicone Base

Designed to lubricate and protect critical brake system componentry while providing reliable stopping power. Advanced chemistry resists corrosion, oxidation and is compatible with SBR, EPDM and natural rubbers. Ideal for use in vehicles where incidental contact of brake fluid can damage finishes.

Exceeds US FMVSS 116 DOT 5 spec. DOT-5 - 16.9 oz Bottle.....MAX80-86916.....\$ 6.95

Exceeds US FMVSS 116 DOT 5.1, DOT 3 & DOT 4, SAE J1703, SAE J1704 and ISO 4925 (Classes 3, 4 and 5.1). DOT-5.1 - 16.9 oz Bottle.....MAX80-82916.....\$9.95



Mud-X Cleaner

Cleans and shines plastic, polycarbonate, chrome, fiberglass, paint, vinyl and leather. Leaves an invisible coating that protects surfaces and repels dirt, dust, fingerprints, smudges and bugs. Excellent for helmet shields. ALL78232.....\$12.99



Ceramic Engine Seal

The best Chemical Sealer you can buy to stop cooling system leaks. Works equally well in aluminum or cast iron blocks. Cooling system must be thoroughly clean before use. Does not work with antifreeze. If this doesn't stop the leaks, find yourself a welder! One Pint Plastic Bottle MOR35500.....\$15.43

Do not use with antifreeze



All Weather Seal

Specially formulated to stop cooling system leaks when antifreeze is present. Ideal for stopping radiator leaks and sealing cracked blocks in sub-freezing conditions. Works best when cooling system has been thoroughly cleaned and flushed.

One Pint Plastic Bottle MOR35520.....\$15.43

Can be used with antifreeze



Lucas Synthetic Oil Stabilizer

Light enough for an import - Tough enough for a semi. Use in new equipment which requires synthetic oils or any equipment that needs enhanced performance. It can also be used to protect new and used Heavy Duty and High Performance transmissions, gear boxes and engines. Controls heat and wear in motorcycles, air-cooled engines and all drive train components. Reduces friction for increased power and MPG. In Ford Powerstrokes we suggest one quart of Pure Synthetic Oil Stabilizer per oil change.

- Increase oil life by at least 50%
- Reduces oil consumption
- Eliminates dry starts
- Raises oil pressure
- Increases power and MPG



Upper Lube

Upper Lube is a high temp cylinder lube that protects and extends engine life. Added directly to the fuel, Upper Lube reduces fuel wash down, chalky residue and corrosion, while lubricating cylinders, valves, guides, and fuel system components. It mixes completely, won't separate from fuel, leaves no varnish residue and does not contain a flame agent. One 16 oz. bottle treats 55 gallons of alcohol, 150 gallons of gasoline, or 110 gallons of ethanol. Upper LubeALL78100.....\$12.99

Upper Lube With Cherry Fragrance
ALL78120.....\$12.99



Speed Wax

Specialized all-in-one detailer that conditions, shines and protects painted surfaces, chrome, anodizing, windscreens and plastic. Advanced formula blends conditioners with color enhancers to produce a brilliant shine. Designed to minimize effort and maximize shine and is the quickest way to detail your ride. Soothing wax sets up quickly and easily wipes from smooth surfaces. Easy application and removal. 17.8 oz. Aerosol.....MAX70-76920.....\$10.50



Biowash Biodegradable Formula

It is a unique, 100% biodegradable all-purpose cleaner. Fast-acting cleaning agents lift away dirt while scrubbing grime and oil based deposits. Specially engineered surfactants, lower surface tension allowing better penetration and wetting of soils. Tough on dirt, yet gentle enough to use on delicate surfaces including paint, plastic, chrome, anodizing, rubber, carbon fiber. Advanced micro chemistry protects aluminum, magnesium and other alloys. Contains no harmful acids, CFC's or solvents. 50 State VOC compliant. 32 oz. Bottle.....MAX85932.....\$8.99



K&N Cleaner and Degreaser

It works to dissolve the dirt build up and old filter oil, and can be washed away with water. Complete instructions on bottle. Do not use on polished or anodized aluminum.

32-fluid oz. squirt bottle ...K&N99-0621...\$9.40
1-gallon refill bottleK&N99-0635...\$22.72



Filtercharger Oil

It is the only oil specially formulated to work in combination with the cotton fabric in K&N Filtercharger elements providing a superior air filtration system. When used as directed, it quickly penetrates the filter pleats, where it remains suspended in the cotton fabric. Saturation is maintained until the element is cleaned with K&N Air Filter Cleaner.

12-oz. aerosol canK&N99-0516...\$6.67
8-oz. squeeze bottleK&N99-0533...\$4.70
1-gallon refill bottleK&N99-0551...\$28.99



Recharger Filter Care Service Kit (Aerosol)

A 6-step maintenance system designed to clean any K&N Filtercharger Air Filter. Restores air flow efficiency so your Filtercharger performs like new! Includes: 6.5 oz. Spray Oil and 12 oz. Filter Cleaner Aerosol...K&N99-5000...\$10.31



(Squeeze Oil)

Same as K&N99-5000 but includes: 8 oz. Squeeze Oil and 12 oz. Filter Cleaner #99-5050

K&N99-5050...\$10.31



Synthetic Air Filter Cleaner

It will bring your K&N synthetic air filter to like new condition. It works to dissolve grime and dirt build up, then it can be washed away with water. It is a great cleaner for K&N Hybrid air filters, K&N Blackhawk air filters, Dryflow air filters and other synthetic air filters.

32-fluid oz....K&N99-0624.....\$9.76



Air Filter Cleaner

Designed to remove grease, heavy filter oils and other contaminants from foam and fabric air filters. Unique and proprietary formulation contains no caustic chemicals, will not damage foam cells, paper or glue and easily washes out with water. Maxima Air Filter Cleaner is consistently ranked as best in class and contains no harmful CFCs.

64 oz. Bottle.....MAX70-79964.....\$19.95
17.1 oz. Aerosol.....MAX79920.....\$9.95



FFT Foam Filter Treatment

Providing unequalled protection against the elements. Unlike other foam filter oils, FFT's time proven formula will not plug foam cells or migrate off of filters. Protective coating catches dirt and fine dust without restricting airflow. Dyed dark blue to ensure even coverage on all surface areas inside and out. Resists washout from carburetor fogging. Water-resistant. The ultimate air filter oil.

16 oz. Bottle.....MAX60916.....\$7.95
32 oz. Bottle.....MAX60901.....\$12.95



FAB-1 Spray-On Air Filter Oil

A highly advanced synthetic based formula for all oil type fabric and foam air filter elements. A superior oil for stopping the passage of dirt, fine dust, water and other harmful elements into the apps intake system. Super tacky polymer and co-polymer additives attract and hold onto virtually all fine dust particles. The water-proof base resists moisture from passing through the filter. Prevents oil "wash out" of the filter from carb fogging and offers the best protection for your engine, spark plugs, carb and air filter.

18.8 oz. Aerosol.....MAX61920.....\$9.50



XPR Racing Oil

They are formulated for demanding applications such as racing, modified engines and off-road use. XPR's high film strength make it exceptionally well-suited for SYNTHETIC OIL today's high performance cars and trucks, particularly turbo and supercharged engines and / or engines using a nitrous boost. XPR produces winning results on the race track and is safe enough to use in your daily commuter car. Professional engine builders and race teams cite increased horsepower and torque, and longer engine life with the use of Royal Purple.

XPR 0W10 Oil.....1 Quart.....ROY01009.....	\$17.44
XPR 5W20 Oil.....1 Quart.....ROY01011.....	\$17.44
XPR 5W30 Oil.....1 Quart.....ROY01021.....	\$17.44
XPR 10W40 Oil.....1 Quart.....ROY01041.....	\$17.44
XPR 20W50 Oil.....1 Quart.....ROY01051.....	\$17.44

Call for Case Special!



Motor Oil

It delivers superior protection and improves performance in four-cycle gasoline and diesel engines. It increases horsepower and torque, saves fuels and reduces heat, wear and emissions. It has unsurpassed oxidation stability that allows for extended oil drains and fewer oil changes, which saves you time and money and reduces the impact on the environment. Royal Purple's performance advantages come from a blend of synthetic oils plus Royal Purple's proprietary synthetic tech. It is compatible with other mineral and synthetic motor oils.

Heavy Duty Motor Oil

SAE 30.....1 Quart.....ROY01030.....	\$9.68
SAE 40.....1 Quart.....ROY01040.....	\$9.68
SAE 50.....1 Quart.....ROY01050.....	\$9.68

Multi-Grade Motor Oil

5w20.....1 Quart.....ROY01520.....	\$8.49
5w30.....1 Quart.....ROY01530.....	\$8.49
10w30.....1 Quart.....ROY01130.....	\$8.49
10w40.....1 Quart.....ROY01140.....	\$8.49
15w40.....1 Quart.....ROY01154.....	\$8.49
20w50.....1 Quart.....ROY01250.....	\$7.86
5w40.....1 Quart.....ROY01540.....	\$8.49

Call for Case Special!



Max EZ

Power Steering Fluid

It is formulated with a blend of select synthetic base oils plus Royal Purple's proprietary Synerlec additive technology, which is proven to make equipment run cooler, smoother, longer, quieter and more efficiently.

1 Pint.....ROY01326.....	\$5.25
--------------------------	---------------



Transmission Fluids

Synchromax "Manual Trans Fluid"

It is also ideal for 4x4 transfer cases and/or 2-cycle motorcycle gear boxes. Synchromax is formulated with Royal Purple's synthetic, proprietary Synerlec additive technology, which offers improved shift quality over a wide temperature range and reduced gear noise. It is fully compatible with all types of friction materials, and offers excellent corrosion and oxidation protection, without affecting the soft metals commonly found in manual trans synchronizers.

ROY01512.....	\$16.55
---------------	----------------



Max-ATF "Dexron/Mercon Auto Trans Fluid"

It is recommended for all automatic transmissions requiring Ford Mercon or GM Dexron III transmission fluids. Max ATF is more oxidation-stable than other transmission fluids, and greatly resists breakdown from heat and loss of proper lubricity. It is fully compatible and can be mixed with other automatic transmission fluids; however, for the best results, drain or flush your current oil and then fill your transmission with Max ATF.

ROY01320.....	\$13.82
---------------	----------------



SC1 High Gloss Coating

Specifically formulated to protect and beautify multiple surfaces such as plastic, vinyl and carbon fiber. Safe for use on plastic, gloss or matte finishes. Excellent for use on plastic fenders, wheel wells and components. Outstanding mud and rubber deflector. Makes the cleaning-up process easier. Can be applied to the surface and left untouched or allowed to setup and buffed to a dry sheen leaving a long-lasting luster without attracting dirt and road debris. Water resistant.

17.2 oz. Aerosol Can.....MAX78920.....	\$10.50
--	----------------



Suspension Clean

Designed to clean suspension internally and externally. Unique and proprietary formulation combines industrial strength cleaners with a powerful spray to ensure maximum cleanliness while leaving a dry and residue free surface. It is strong enough to eliminate tough-to-clean grime and debris, but safe enough for incidental contact with Nitrile (buna-n), Viton and most seal materials.

18.1 oz. Aerosol Can.....MAX71920.....	\$8.95
--	---------------



Contact Cleaner

Designed to remove grease, oil and other contaminants from electrical components. Unique and proprietary formulation displaces moisture and is completely non-corrosive & non-staining. CFC-free & VOC compliant cleaner safely cleans electrical components, dries quickly & leaves behind no moisture, residue or film.

17.5 oz. Aerosol.....MAX72920.....	\$6.95
------------------------------------	---------------



Chain Wax

It is a paraffin bike chain lube that goes on wet. It penetrates rollers and side plates, then sets up to a soft, pliable wax. The chain will be encased in a protective layer and shielded from the harsh elements of dirt, grime & water. Special low melt point wax replenishes drive train by drip-feeding clean lube from the inside layers outward, significantly reducing abrasive wear and eliminating corrosion. Smooth, quiet, trouble-free operation in all conditions. Waterproof. Long lasting protection for all cyclists.

7.4 oz. Aerosol.....MAX74908.....	\$7.50
18.1 oz. Aerosol.....MAX74920.....	\$11.50



Clean Up Chain Cleaner

It is a heavy duty, emulsion type cleaner designed to thoroughly clean chains without harming rubber o-rings or metal surfaces. Quickly dissolves and removes left on chain lube, dirt, sand, mud and other grime. Doesn't harm the finish on gold chains, standard chains, aluminum or steel. Safe for O, X and Z-ring chains.

17.1 oz. Aerosol.....MAX75920.....	\$9.95
------------------------------------	---------------



Synthetic Chain Guard

It is an exclusive 100% synthetic bike chain lube. Special surface active formula reduces rolling resistance of drivetrain and improves shifting performance. Deep chain penetration ensures quiet operation, protects drivetrain under load and extends chain life by shielding it from the elements dirt, grime & water. Waterproof. Ideal for use on both short and long rides.

7.4 oz. Aerosol.....MAX77908.....	\$7.50
17.3 oz. Aerosol.....MAX77920.....	\$11.50



HPS w/Synerlec High Performance Street Motor Oil

Synerlec significantly increases oxidation stability for longer oil life. Improved oil life let's you go further between oil changes. Fewer oil changes saves time, money and reduces the impact on the environment. Royal Purple's proprietary additive technology. Synerlec significantly increases oil film strength which. High film strength reduces wear and improves sealing in the combustion chamber. Improved combustion increases horsepower and torque, saves fuel and reduces emissions.

HPS 5W-20.....1 Quart.....ROY31520.....	\$8.97
HPS 5W-30.....1 Quart.....ROY31530.....	\$8.97
HPS 20W-50.....1 Quart.....ROY31250.....	\$8.97

Max Gear Oil SAE 75W90

It is an ultra-tough, high perf, GL-5 automotive gear oil designed to provide maximum protection to heavily loaded gears while maximizing power output throughout the drive train. Max-Gear makes gears run smoother, quieter, cooler & longer without overhauls.

75W90.....ROY01300.....	\$16.13
-------------------------	----------------

Max Gear Oil SAE 75W140

Royal Purple's Max-Gear is an ultra-tough, high-performance, GL-5 automotive gear oil designed to provide maximum protection to heavily loaded gears, while maximizing power throughout the drivetrain. It outperforms many other oils because it combines the highest quality synthetic oils with Royal Purple's proprietary Synslide additive technology. Max-Gear makes your gears run smoother, quieter, cooler, and longer without overhauls.

75W140.....ROY01301.....	\$19.21
--------------------------	----------------

Break-In Oil

Royal Purple Break-in Oil is formulated to allow optimal ring seal and protect rotating assembly components, such as the camshaft and valve train from initial start up wear. It combines highly refined mineral oil, preferred for engine break-in, with advanced additives; containing high levels of zinc and phosphorus to optimize protection in flat tappet and roller engines.

1 Quart.....ROY11487.....	\$8.70
---------------------------	---------------

Max Cycle SAE20W50

This Royal Purple Max-Cycle motor oil is specifically formulated to improve motorcycle engine performance. It features a select synthetic base oil and Royal Purple's proprietary Synerlec additive technology. Max-Cycle provides unparalleled film strength that is up to 400 percent stronger than the leading synthetic and mineral oil.

1 Quart.....ROY01316.....	\$13.61
---------------------------	----------------

Purple Ice Coolant Additive

Purple Ice is a high perf radiator conditioner. Its advanced 2-in-1 corrosion inhibitor and wetting agent provides year-round defense against corrosion. Purple Ice also reduces the surface tension of the radiator coolant to help reduce engine temps. Extensive testing confirms Purple Ice reduces coolant temps better than comparable products while providing extra corrosion protection.

ROY01600.....	\$9.71
---------------	---------------

Assembly Lube

Max Tuff "Compatible with conventional and synthetic oils" Royal Purple Max-Tuff is an ultra-tough synthetic lubricant designed for use in reassembling repaired equipment. Royal Purple Max-Tuff assembly lube utilizes unique synthetic molecules that adhere tenaciously to metal surfaces to create a formidable load-bearing physical barrier between surfaces. This minimizes the possibility of boundary conditions, while providing excellent protection to both ferrous and non-ferrous metals against rust and corrosion.

ROY11335.....	\$16.19
---------------	----------------

SynFilm

SynFilm 32 Multi Purpose Synthetic Lubricant. Great for air tools, fishing reels, guns, fans, hinges, locks, bearings, and much much more. A must for every toolbox! Royal Purple SynFilm Recip. 100 is recommended for lubricating reciprocating air compressors (piston type).

ROY02514.....	\$3.30
---------------	---------------



RS Series Engine Oils

It is a 100% synthetic triple ester based race-grade engine oil. Technologically advanced formula contains special anti-wear/extreme pressure additives to protect critical engine components from extreme loads & peak temps generated by high-perf engines. Delivers increased hp & torque, superior engine cleanliness, reduces wear on bearings, cams, lifters, crankshafts and extends engine life. High Zinc/Phosphorous formula engineered for use in flat tappet & roller element engines.



0W-10 - 32 oz Quarts.....	MAX39-13901.....	\$13.95
0W-20 - 32 oz Quarts.....	MAX39-14901.....	\$13.95
5W-20 - 32 oz Quarts.....	MAX39-04901.....	\$13.95
5W-30 - 32 oz Quarts.....	MAX39-91901.....	\$13.95
10W-30 - 32 oz Quarts.....	MAX39-01901.....	\$13.95
10W-40 - 32 oz Quarts.....	MAX39-16901.....	\$13.95
10W-50 - 32 oz Quarts.....	MAX39-32901.....	\$13.95
5W-30 - 128 oz Gallons.....	MAX39-919128.....	\$53.95
10W-30 - 128 oz Gallons.....	MAX39-019128.....	\$53.95
10W-40 - 128 oz Gallons.....	MAX39-169128.....	\$53.95
15W-50 - 128 oz Gallons.....	MAX39-329128.....	\$53.95

Performance Engine Oils

Special anti-wear/extreme pressure additives protect critical engine components from extreme loads and peak temps generated by high-performance engines. Advanced, shear-stable polymers resist mechanical break-down & viscosity loss of the oil. Performance delivers increased horsepower, optimum engine cleanliness, reduces wear on bearings, cams, lifters, crankshafts and extends engine life. High Zinc/Phosphorous formula engineered for use in flat tappet and roller element engines.



10W-30 - 32 oz Quarts.....	MAX39-33901.....	\$7.95
10W-40 - 32 oz Quarts.....	MAX39-34901.....	\$7.95
20W-50 - 32 oz Quarts.....	MAX39-35901.....	\$7.95
20W-50 - 128 oz Gallons.....	MAX39-359128.....	\$28.95

Performance Straight-Weight Engine Oils

Designed to enable max power while providing ultimate protection under the most severe race conditions. The extensively developed formulation utilizes a 2X Zinc system combined with unique "stay-in-place" chemistry for protection during every run. High quality base oils combine with an advanced, proprietary additive system to provide world-class durability through effective ring seal, optimum engine cleanliness & resistance to separation caused by fuel dilution.



50WT - 128 oz Gallons.....	MAX39-36128.....	\$8.99
60WT - 128 oz Gallons.....	MAX39-37128.....	\$8.99
70WT - 128 oz Gallons.....	MAX39-38128.....	\$8.99

Semi-Syn Engine Oils

It is a complex blend of synthetic esters & highly refined petroleum base stocks offering protection beyond conventional oils. Tech advanced additives containing special anti-wear/extreme pressure additives protect critical engine components from extreme loads and peak temps generated by high-perf engines. Advanced, shear-stable polymers resist mech break-down and viscosity loss of the oil. It delivers increased hp, optimum engine cleanliness, reduces wear on bearings, cams, lifters, crankshafts and extends engine life. High Zinc/Phosphorous formula engineered for use in flat tappet and roller element engines.



10W-40 - 32 oz Quarts.....	MAX39-34901B.....	\$9.95
20W-50 - 32 oz Quarts.....	MAX39-35901B.....	\$9.95
10W-40 - 128 oz Gallons.....	MAX39-349128B.....	\$35.95
20W-50 - 128 oz Gallons.....	MAX39-359128B.....	\$35.95

HD Diesel Engine Oil

Advanced chemistry blended with high-quality petroleum base stocks offer excellent protection from the stresses of heat, soot and acids preventing wear from deposits and corrosion. Elevated levels of detergent/dispersant help to eliminate the formation of larger combustion particles minimizing soot-related viscosity increase allowing for improved drain intervals. Highly refined petroleum base stocks provide outstanding lubricity and resist oil loss due to oil volatilization.



15W-40 - 128 oz Gallons.....	MAX39-029128.....	\$28.95
------------------------------	-------------------	---------

Performance Break-In Engine Oils

Designed for breaking in engines with flat tappet camshafts, roller elements or where elevated levels of anti-wear additives are needed. Complex 2X Zinc structure protects for an extended temp range, outperforming conventional break-in oils. By combining 2 different zinc compounds, activates at lower temps and offers more protection at elevated temps. Promotes ring seal and provides max protection for cams and all critical valve train components during initial break-in of flat tappet and roller cam engines. Compatible with petroleum, semi-synthetic and fully synthetic motor oils. **NOT RECOMMENDED FOR STREET USE.**



5W-16 - 32 oz Quarts.....	MAX39-09901.....	\$7.95
10W-30 - 32 oz Quarts.....	MAX39-10901.....	\$7.95
15W-50 - 32 oz Quarts.....	MAX39-11901.....	\$7.95
10W-30 - 128 oz Gallons.....	MAX39-109128.....	\$28.95
15W-50 - 128 oz Gallons.....	MAX39-119128.....	\$28.95

Pro Gear

Regenerative, synthetic polymers resist shearing, mech breakdown and viscosity loss of the oil. High viscosity index (VI) formula offers consistent film thickness and performance over a greater operating temp range. Tech advanced formula increases hp and delivers superior anti-wear and extreme pressure protection from peak loads and elevated temps. Surface active chemistry delivers ultra-high film adhesion on gear faces, enabling higher load carrying capability and protecting critical gear interface areas and contact points. It is recommended for use in front and rear differentials, manual transmissions and lower gear units of marine engines or anywhere an API GL-5 gear oil is specified.



75W-90 - 32 oz Quarts.....	MAX49-44901.....	\$15.95
75W-140 - 32 oz Quarts.....	MAX49-45901.....	\$17.95
75W-90 - 128 oz Gallons.....	MAX49-449128.....	\$60.95
75W-140 - 128 oz Gallons.....	MAX49-459128.....	\$68.95
75W-190 - 128 oz Gallons.....	MAX49-469128.....	\$68.95
250 WT - 128 oz Gallons.....	MAX49-479128.....	\$79.95

Performance Gear Oil

Ultra-pure, high quality base oils & thickeners resist shearing, mech breakdown and viscosity loss of the oil. High viscosity index (VI) formula offers consistent film thickness and performance over a greater operating temp range. Tech advanced formula delivers superior anti-wear and extreme pressure protection from peak loads and elevated temps. Surface active chemistry delivers ultra-high film adhesion on gear faces, enabling higher load carrying capability and protecting critical gear interface areas and contact points. Fully formulated additive system contains anti-foam, rust, corrosion and oxidation protection for high stress conditions.



85W-140 - 128 oz Gallons.....	MAX49-429128.....	\$49.95
250 WT - 128 oz Gallons.....	MAX49-439128.....	\$59.95

SYN ATF Auto Trans Fluid

Advanced anti-foam agents minimize air entrapment in the oil and protect critical trans components at higher speeds seen in racing conditions. Exhibits excellent wetting properties enabling increased heat transfer & lowering overall operating temps. Superior additive package is oxidative and thermally stable inhibiting the formation of lacquer, varnish & harmful deposits ensuring clean, trouble-free operation. No slip formula offers positive shift engagement & reduces clutch drag.



10 WT - 32 oz Quarts.....	MAX49-00901.....	\$10.95
20 WT - 32 oz Quarts.....	MAX49-01901.....	\$10.95
30 WT - 32 oz Quarts.....	MAX49-02901.....	\$10.95
30 WT - 128 oz Gallons.....	MAX49-029128.....	\$38.95

SYN Power Steering Fluid

Racing power steering systems operate under increased loads and elevated temps when compared to on-highway systems. SYN PSF uses tech advanced additives to prevent wear, thermal breakdown and oxidation - offering unsurpassed protection to pumps, cylinders, valves and gears. Special conditioners keep seals and O-rings pliable under extreme conditions. Full synthetic formula delivers consistent steering response and exhibits excellent flow at low temps. LW formula reduces initial drag on pump avoiding power losses.



32 oz Quarts.....	MAX89-01901.....	\$12.95
-------------------	------------------	---------

Hi Test Octane Booster

Designed to increase power by increasing octane number and combustion efficiency. The advanced formulation eliminates knocking by increasing the auto-ignition temp of the air/fuel mixture and readily mixes with all fuels, including nitro and alcohol mixtures. The all organic blend contains no metal or phosphorus compounds and effectively increases power at dosages as low as 1 oz. HI-TEST per gallon of fuel.



16 oz. Bottle.....	MAX83916.....	\$6.50
--------------------	---------------	--------

Cool-Aide

Ready-to-use mix of powerful additive & deionized water. Formulated to reduce engine temps & provide significantly better contact on heated surfaces allowing for greater & more efficient heat transfer. Glycol, Nitrate, Amine, Borax free. Add to any cooling system (water or antifreeze). Non-slippery if spilled on paved surfaces. Approved & safe for use in most racing series.



Concentrate - 16 oz Bottle.....	MAX84916.....	\$9.95
Ready-to-use - 64 oz Bottle.....	MAX84964.....	\$9.95

PSO Race Oils

PSO is a 100% ester-based synthetic engine oil. Advanced formula contains surface active chemistry, drastically reducing friction and offering unsurpassed anti-wear/extreme pressure protection from extreme loads generated by high-perf engines. Ester synthetics resist mechanical break-down & viscosity loss of the oil and special additives offer consistently high vacuum. PSO delivers increased hp & torque, superior engine cleanliness, reduces wear on bearings, cams, lifters, crankshafts & etc.



Shock Synthetic Fluid

Designed to ensure max perf and provide max protection under the most severe conditions. Shear stable, ultra-high viscosity index (>350) formulation maintains film strength & reduces wear under extreme temps. Ultra clean formulation eliminates corrosion, conditions seals and extends equipment life.



Shock Racing Fluid

Designed for use in high performance shocks. Shear stable, high (300+) viscosity index formulation maintains viscosity and film strength while reducing wear. Advanced additive system minimizes stiction and reduces running friction while minimizing foaming and air entrapment. Ultra clean formulation eliminates corrosion, conditions seals and extends equipment life.



Castor 927

Designed to ensure max performance while providing max protection under the most severe conditions. Carbonization and vaporization resistant formulation combines surface-active esters with a highly-refined castor oil to provide excellent film thickness and surface tenacity, protecting cylinder walls, journals and other critical areas. Proprietary ash-free additive system keeps your engine running clean and free of gum formation, corrosion and deposits.



16 oz Bottle.....	MAX22916.....	\$10.95
Liter Bottle.....	MAX22901.....	\$19.95
64 oz Bottle.....	MAX22964.....	\$36.95

MTL Trans Lube

Mineral based motorcycle trans lubricant formulated for use in both 2-stroke and 4-stroke trans. Provides excellent film thickness and viscosity stability across all operating temps for max clutch and gear protection. Proprietary ClutchSaver formula ensures optimal clutch engagement, prevents slippage and minimizes wear. Exceeds the requirements of JASO MA2.



Liter Bottle.....	MAX42901.....	\$9.95
-------------------	---------------	--------

Formula K2

Full synthetic, triple ester 2-stroke engine oil designed to ensure optimum protection and performance under extreme race conditions. Clean burning, ring stick resistant formulation utilizes high molecular weight, surfaceactive esters to ensure optimal ring seal and maximum power. Advanced, low-ash additive system minimizes carbon build up while preventing rust, corrosion and wear.



16 oz Bottle.....	MAX22916.....	\$10.95
Liter Bottle.....	MAX22901.....	\$19.95
64 oz Bottle.....	MAX22964.....	\$36.95

Fuel Enhancer

Designed to prevent and cure all problems caused by ethanol due to ethanol's corrosivity and high affinity for water. Fuel Enhancer prevents water and ethanol from reaching critical components and can help prevent corrosion where water has previously been introduced.



1 oz. Pillow Pouch.....	MAX80-89930.....	\$1.95
32 oz. Bottle.....	MAX80-89901.....	\$19.95

INDEX

A

Accelerator Pump Cam	92
Accelerator Pump Kit	92
Access Panel Kits	117
Accumulator Mounts	54
Adapter Plates	102
Adjusting Rods	64
Aeromotive	94-95
A-Frames	119
Air Box	196
Air Cleaner Adapters	86
Air Cleaner Bottoms	86
Air Cleaner Spacers	86
Air Cleaner Stud Kits	86
Air Cleaner Tops	86, 165
Air Cleaners	86
Air Filter Cleaner	85, 205
Air Filter Degreaser	85
Air Filter Foam	85-86
Air Filter Gaskets	110
Air Filter Gaskets	86, 93
Air Filter Plates	84, 86
Air Filter Sealing Grease	85
Air Filter Stud Kits	86
Air Filter Tops	84-86
Air Filters	84-85
Air Jacks	163
Air Mover Fan	149
Air Pressure Gauge	158, 163
Air Rivet Gun	125
Air Tank	163
Alpinestars	22-23
Alternator Brackets	38
Alternator Kits	64-65
Alternator Mounts	66
Alternator Pulleys	38
Alternator Relays	40
Alternators	38, 65
Aluminum Fans	63
AN Caps	97
An Fittings	44-53
AN Plugs	97
Angle Gauge	158
Anodized Fittings	49-51
Anti Bind Radius Rod Sys	113
Anti Roll Kits	202
Anti Roll Stop	134
Aprons	149
Arm Restraints	9, 17, 28
Art's Radiators	61
Assembly Grease	155, 203
Assembly Lube	206
ATL Fuel Cells	98-99
Autolite Spark Plugs	81
Autometer Gauges	34-35
Axle Hex Nuts	193
Axle Puller	164
Axle Spacer Kit	193
Axle Spline Tool	164
Axle Strap	151
Axle Tubes	174, 183
Axles	170, 180, 183, 190

B

Back Up Washers	126
Bags	29
Bail Handle Caps	97
Balance Bar Assembly	175
Balance Bars	136
Balancer Bolts	105
Ball Joint Holders	119
Ball Joint Socket	119
Ball Joints	118
Ball Spline Driveshafts	188
Ball Valves	195
Ballast	117
Ballast Brackets	114
Ballast Mounts	114
Ballast Weight Mount Bar	173
Banjo Adapters	140
Banjoes Fittings	48
Bat Wing Pickup	97
Batteries	42-43
Battery Boxes	41

Battery Cables	38-39, 41
Battery Chargers	42-43
Battery Connectors	38-39, 41
Battery Disconnect Sw	36, 39, 41
Battery Kill Switch	38
Battery Terminals	39, 41
Battery Wrap Heat Barrier	104
Bead Breaker	160
Beadlock Zerks	168
Beadlocks	168
Bearing Packer	175
Bearings	170-171, 189, 192
Bell Helmets	18-19
Bellhousing	176, 182
Bellhousing Plate	184
Bellhousings	184
Bert Transmission	184-187
Big Bearing Spacers	175
Big Head Buttons	120
Bilstein Shocks	144-145
Birdcage Cups	174
Birdcages	174, 190, 193
Bleeders	130
Block Plates	59
Blocks	95
Blow Gun	162
Body Bolts Kits	117, 135
Body Brace Kit	117
Body Brace Mounts	180
Body Panels	180
Body Radius Tool	117
Body Supports	180
Bolt Extractor Kit	164
Boost Gauges	35
Boot Covers	9, 27
Boots	17
Braided Hose	45
Braille Batteries	43
Brake Adapters	48
Brake Balance Panel	36
Brake Balancer Assembly	138
Brake Bias Cable	134
Brake Bias Gauges	138
Brake Bottles	139
Brake Caliper Mounts	197
Brake Caliper Pistons	130
Brake Calipers	128-130, 138-139
Brake Deflectors	140, 172
Brake Duct Hose	134
Brake Ducts	134
Brake Fittings	140
Brake Fluid	134, 139, 204-205
Brake Hubs	134
Brake Kits	135
Brake Line Adapter Tabs	114
Brake Line Kits	197
Brake Lines	140
Brake Pads	128-130, 138-139
Brake Parts Cleaner	203
Brake Pedal Assembly	136, 175
Brake Rotor Adapter	133
Brake Rotor Hats	133
Brake Rotors	131-133, 139
Brake Shut Offs	137, 139, 175
Bras	9
Break In Oil	203, 206-207
Breath Deflector	15, 18
Breather Baffle	55
Breather Cans	194
Breather Grommet Baffle	55
Breather Tanks	54, 56
Breathers	54, 55, 85
Bridge Bolts	130
BSC Radiators	60
Bulk Gaskets	111
Bulkhead Fittings	47
Bump Spring Caps	143
Bump Steer Gauge	149, 159
Bump Stops	146
Bumper Bolts	125
Bumpers	180, 190
Bushings	75
Buttons	120-121, 124

C

Caliper Adapters	140
Caliper Brackets	172, 175
Caliper Mounts	197

Calipers	128-130, 138-139
Cam Bearing Install Tool	156
Cam Bolt Kits	107
Camshaft	109
Camshaft Installation Tool	153
Caps	48, 76-77, 125, 155
Car Covers	151
Carburetor Throttle Ball	92
Carbuertor Tops	93
Carburetor Adapters	47, 53, 91
Carburetor Case	90
Carburetor Drain Cup	152
Carburetor Fittings	91
Carburetor Fuel Line Kits	90
Carburetor Gaskets	110-111
Carburetor Hats	93
Carburetor Jet Tool	152
Carburetor Jets	92
Carb Linkage Bushing	100
Carburetor Spacers	93
Carburetor Stands	93
Carburetor Throttle Adj	92
Carb Throttle Cable Bkt	92
Carburetor Throttle Stud	92
Carburetor Tool Trays	93
Carburetor Tote	90
Carburetor Work Stand	93, 152
Carburetors	89-91
Carburetr Regulators	94-95
Carrier Fasteners	107
Caster Camber Gauge	149, 159
Catch Cans	96
C-Clips	130
Center Links	119
Ceramic Engine Seal	205
Chain Cleaner	206
Chain Wax	206
Champion Spark Plugs	81
Chassis Brackets	114
Chassis Ride Hgt Gauge	161
Check Valve Kits	89
Check Valves	96, 134, 157
Cheek Pads	174
Chicklets	14
Child Seats	31
Clamp On Heat Shield	104
Clamp On Rings	116
Cleaner	205
Cleaning Brushes	153
Cleco Fasteners	116
Cleco Pins	125
Clevis	112, 115
Clips	180
Clutch Cover Bolt Kits	106
Clutches	189
Cog Pulleys	57
Coil Bracket Bolt Kits	106
Coil Brackets	69
Coil Mounts	164
Coil Over Adapter	141, 175
Coil Over Kits	145, 146, 148
Coil Over Load Bolt Assy	115
Coil Over Spring Rater	158
Coil Over Spring Rubbers	141-143
Coil Over Wrench	165
Coil Selectors	69
Coil Spring Shims	115
Coil Spring Spacer	115
Coils	69, 71, 74
Compression Sleeves	52
Compression Tester	156
Compressor	154
Compressor Tester	158
Connecting Rods	106
Connectors	80
Control Arm Bushings	119
Control Arms	119
Converter Bolts	106
Coolant Check Valve	157
Coolants	203-204, 206-207
Cotter Pins	130
Cowling	180
Cradle Wheel Kits	116
Crank Couplers	188
Crank Sockets	153
Crank Throttle Linkage Kit	195
Crank Triggers	75
Crankcase Evac System	101

Crankcase Vent Filters	85
Crankshaft	107
Crankshaft Containers	106
Crankshaft Socket Tools	57, 153
Crankshaft Wipers	54
Crate Motor Section	198-201
Crimp Tools	77, 156
CV Fuel Pumps	89
Cylinder Head Bolts	108
Cyl Head Work Stand	152
Cyl Leak Down Gauges	154
Cylinder Leakage Tester	154

D

Dampers	105
Dashboard Gauge Grommet Seal	36
Daytona Sensors	78
Deburring Tool	124
Degreaser	85, 155, 205
Degree Wheel	153
Depth Gauge	158
Deutsch Connectors	80
Dial Caliper	155
Dial In Marker Holder	150
Diaphragm	89, 92
Dies	77
Digital Caliper	162
Digital Level	149
Digital Multi Retard	77
Dipsticks	54, 99, 202
Direct Mount Hubs	192
Dirt Ignition Boxes	71
Disconnect Switches	36, 39, 41
Distributor Caps	76-77
Distributor Coils	69
Distributor Gear Shim Kit	83
Distributor Gears	75
Dist Hold Down Clamps	75, 83
Distributor Rotors	76
Distributor Stud Kits	105
Distributors	72-75, 83
Door Supports	180
Dowty Seals	48
Draco Springs	141
Drag Boots	17
Drag Gloves	17
Drag Racing Section	202
Drag Racing Tree	156
Dragster Fillers	97
Drain Plug	165
Drain Plug Washers	54
Drill Bits	38, 124, 164
D-Rings	121
Drip Cups	148
Drip Tray	155
Drive Flanges	174, 184
Drive Mandrels	57
Driveshafts	176, 182
Driver Earpiece	20-21
Driver Gloves	11, 16-17, 20, 23, 30
Driver Shoes	11, 16, 20, 23, 27, 30
Driver Suits	10, 16, 22, 27, 30
Driveshaft Covers	176
Driveshafts	188, 194
Drum Wrench	150
Dry Break	99
Dry Break Valves	96
Dry Sump Oil Tanks	54
Dry Sump Pumps	55
Dry Sump Ret Manifolds	57
Dump Cans	96, 99
Durometer	158, 162
Dynamometer	156

E

Earls Plumbing	44-52
Earmolds	21
Earpiece	20-21
Earplugs	164
Eibach Springs	143
Elbow Fittings	46
Elbows	102
Electric Fuel Pumps	88-89
Electrical Repair Kits	40
Engine Assembly Lube	155, 204
Engine Cleaning Brushes	153
Engine Cradles	116, 149
Engine Fastener Kits	105
Engine Heater	157

Engine Hoods.....	180	Fuel Cell Replace Can.....	98	Helmet Cheek Pads.....	14	Jugs.....	150
Engine Leak Down Tester.....	154	Fuel Cell Tip Over Valve.....	97	Helmet Dryer.....	8	K	
Engine Lift Plates.....	116, 155	Fuel Cells.....	96-99	Helmet Fans.....	8	K&N Air Filters.....	84-85
Engine Mounts.....	175	Fuel Directors.....	91	Helmet Hooks.....	165	K1 Race Gear.....	30
Engine Oil.....	203, 206-207	Fuel Filters.....	93, 95, 100	Helmet Restraints.....	9	Kart Jackets.....	11
Engine Plates.....	180	Fuel Jug Covers.....	104	Helmet Shelves.....	150	Key Ways.....	174
Engine Seal.....	205	Fuel Level Sending Unit.....	97	Helmet Shields.....	7, 15, 19, 26	King Pins.....	171, 192, 194
Engine Storage Bag.....	153	Fuel Line.....	48	Helmet Skirts.....	9, 17, 22, 28	Kirkey Seats.....	31-33
Exhaust Adapter Plates.....	102	Fuel Line Kits.....	52	Helmet Speakers.....	20	Knee Guard.....	33
Exhaust Elbows.....	102	Fuel Line Kits.....	90	Helmets.....	6-7, 14-15, 18-19, 20, 26	L	
Exh Header Gasket.....	102-103, 110-111	Fuel Logs.....	89, 90-91, 95	Helper Springs.....	142-143	Laser Scale Pad Leveler.....	156
Exhaust Headers.....	102-103	Fuel Overflow Catch Can.....	96	Hex Suspension Tubes.....	112	Lead Ballast.....	117
Exhaust Heads.....	108	Fuel Pressure Gauges.....	52, 95, 117	Hi Heat Coating.....	101	Leaf Spring Perch.....	115
Exhaust Insulating Wrap.....	104	Fuel Press Regulator.....	88-89, 94-95	Hinge Kits.....	117	Leaf Spring Slider Box.....	115
Exhaust Jackets.....	104	Fuel Pump Block Off Plate.....	87	Hold Down Clamps.....	75, 83	Leak Down Tester.....	196
Exhaust Mounts.....	101	Fuel Pump Bolt Kits.....	87	Hold Down Tabs.....	55	Leg Protector.....	33
Exhaust Mufflers.....	102-103	Fuel Pump Brackets.....	95	Hole Saws.....	164	Leg Supports.....	33
Exhaust Port Covers.....	102	Fuel Pump Check Valve.....	89	Holley Carburetors.....	90-91	Level.....	149, 159
Exhaust Reducers.....	102	Fuel Pump Pushrods.....	109	Holley Fuel Pumps.....	88-89	Lever Shifters.....	116
Exhaust Tail Pipe Kits.....	103	Fuel Pump Relays.....	40	Honeycomb Radiator Mts.....	196	Lifters.....	109
Exhaust Tri-Y Headers.....	102-103	Fuel Pump Seal.....	87	Hood Blanket.....	192	Limiters.....	148
Exhaust Tubing.....	102	Fuel Pumps.....	88-89, 94	Hood Pin Kits.....	117	Line Wrenches.....	155
Exhaust Turnouts.....	102	Fuel Rail Kits.....	95	Hood Scoops.....	86	Linear Floor Slider.....	178
Expansion Rings.....	168	Fuel Sample Valves.....	88	Hoods.....	180	Link Brackets.....	119
Expansion Tanks.....	61-62	Fuel Shut Off Valves.....	52	Hooks.....	66	Lock Tool.....	170
F		Fueler Aprons.....	149	Hoops.....	178	Locking Collars.....	173
Falcon Shorty Trans.....	176	Full Containment Seats.....	31-32	Hose.....	8, 45	Locknuts.....	125
Falcon Transmission.....	188	Fuel Spools.....	166	Hose Clamps.....	44, 62	Louvered Windage Trays.....	54
Fan Mounting Kits.....	63	Funnels.....	150	Hose Ends.....	44-45, 49, 53	Lower Shaft Bearings.....	182
Fan Relays.....	40	G		Hose Fillers.....	62	Lower Shafts.....	194
Fan Shrouds.....	61-62	Gas Fill Tool.....	145	Hose Separators.....	48	Lower Spring Pads.....	115
Fan Spacer Kits.....	63	Gas Pedal.....	117, 175	Hot Lap.....	204	Lower Spring Plates.....	115
Fans.....	63, 65	Gaskets - Bulk.....	111	HTD Belts.....	54, 65	Lowering Blocks.....	115
Fast Fill Valves.....	97	Gaskets.....	110-111	Hub Bearing Kits.....	116	Lug Nuts.....	160
Fastener Wrench.....	124	Gaskets.....	110-111	Hubs.....	66, 134, 192	Lug Wrench.....	160-161
Fasteners.....	120-124	Gauge Panels.....	36-37	Humidity Gauge.....	169	Lumbar Supports.....	33
Feeler Gauge.....	152	Gauge Window Frames.....	114	HVC Coils.....	69-70		
Fel-Pro Gaskets.....	110-111	Gauge Wires.....	39	Hybrid.....	25	M	
Fender Filler Kit.....	97	Gauges.....	34-37	Hydraulic Release Bearing.....	189	Magnetic Triggers.....	80
Fender Support Kit.....	165	Gear Bags.....	29	Hypercoils.....	142	Magneto Signal Converter.....	37
Filler Necks.....	62	Gear Oils.....	203, 206-207	I		Magnifying Flashlight.....	83
Filter Cleaner.....	85	Gear Totes.....	150, 177	I-Beam Rods.....	106	Main Jets.....	92
Filter Degreaser.....	85	Gears.....	75, 177	Idler Gear.....	184	Main Studs.....	107
Filter Screens.....	57	G-Force.....	26-28	Idler Gear Bushing.....	184	Mandrel Bolts.....	57
Filtercharger Oil.....	85	Gilmer Belts.....	54	Idler Gear Shaft Grease Fit.....	184	Mandrel Spacers.....	57
Filters.....	84-85	Gloves.....	11, 16-17, 20, 23, 27, 30	Idler Gear Spring.....	184	Manifold Bolt Kits.....	108
Fire Extinguisher.....	150	Go Pro Mount.....	158	Idler Gear Washer.....	184	Manifold Bolts.....	87
Fire Suits.....	10, 16, 20, 22, 27, 30	Goodridge.....	53	Ignition Box Mounts.....	70	Manifold Filler Neck Kits.....	62
Fittings.....	44-53	Grinding Wheel.....	153	Ignition Boxes.....	70-71	Manifold Gaskets.....	87, 110-111
Flame Guard Sleeve.....	45	Grooving Heads.....	160	Ignition Coils.....	69	Manifolds.....	87
Flame Proof Paint.....	101	Grooving Iron Holder.....	161	Ignition Wires.....	74	Manual Compressor.....	154
Flange Bearings.....	68	Guide Plates.....	109	Impact Racing.....	14-17	Manual Piston Ring Filer.....	106
Flanged Jam Nuts.....	112	Gusset Tabs.....	114	Impact Guns.....	160	Maradyne Fans.....	63
Flapper Valve.....	99	Gussets.....	125	Impact Helmets.....	14-15	Marker.....	160
Flare Tool.....	149	H		In Line Duct Blowers.....	116	Master Cyl Rebuild Kits.....	130
Flashlight.....	152	Hans Device.....	24	In Line Fuel Filters.....	95, 100	Master Cylinders.....	137
Flat Spacers.....	126	Harmonic Balance Bolts.....	105	In Line Oil Coolers.....	56	Mats.....	150
Flat Tabs.....	114	Harmonic Bal Install Tool.....	153	Indexing Washers.....	83	Max Papis Innovations.....	67
Flexplate Bolt Kits.....	106	Harmonic Dampers.....	105	Inline Ball Valves.....	100, 195	Maxima Racing Oils.....	205, 207
Flexplates.....	189, 202	Harness Pads.....	28	Inner Bushing.....	115	Mechanical Fuel Pumps.....	88-89
Float Adjusting Tool.....	152	Hawk Brake Pads.....	138	Inspection Plugs.....	179, 194	Metering Block Gasket.....	92
Floor Mount Gas Pedal.....	117	H-Beam Rods.....	106	Insulating Blanket.....	101	Metris Spindle Gauge.....	115
Flush Head Buttons.....	120, 124	Head and Neck Restraints.....	24-25	Insulating Header Wrap.....	101	Metris Spindle Savers.....	115
Flwheel Housing.....	188	Head Bolts.....	108	Insulating Mat.....	104	Mid Plates.....	116
Flywheel Adapter.....	184	Head Gaskets.....	110-111	Insulating Sleeves.....	104	Mini Breather Tanks.....	54
Flywheel Bolt Kits.....	107	Head Skirts.....	9, 28	Insulating Wrap.....	104	Mini Spools.....	166
Flywheels.....	38, 176, 184	Head Socks.....	9, 22, 28, 30	Intake Gaskets.....	110-111	Mini Springs.....	179
Foam Filter Shields.....	86	Head Stud Kits.....	108	Intake Manifold Bolt Kits.....	108	Mini Valve Spring Tester.....	154
Foam Kits.....	85	Head Supports.....	31, 33	Intake Manifold Bolts.....	87	Mirrors.....	165
Foam Sheets.....	33	Header Bolt Locking Washers.....	103	Intake Manifold Gaskets.....	87	Modified Shifter Kit.....	185
Fox Springs.....	146-147	Header Bolts.....	101, 103	Intake Manifold Gaskets.....	87	Module Bypass Cables.....	80
Fram Oil Filters.....	57	Header Gaskets.....	102, 103, 110-111	Intake Manifolds.....	87	Module Holders.....	77, 79
Freeze Plugs.....	156	Header Gaskets.....	102, 103, 110-111	Integra Shocks.....	145	Module Kits.....	71, 77
Front Axle Bracket.....	172	Header Manifold Blanket.....	104	J		Module Selectors.....	79
Front Axles.....	170, 180, 190	Header Studs.....	101	Jack Bolt Collar.....	115	Modules.....	72
Front Clips.....	180	Header Tab Kits.....	101	Jack Stands.....	163	Molded Hoses.....	62
Front Hub Kit.....	170	Headers.....	102-103	Jacks.....	163	Molecule Cleaner.....	10
Front Hubs.....	192	Headlock Locking Bolts.....	103	Jacobs Ladder.....	190	Moose Blocks.....	149
Front Spindles.....	170-171	Heads.....	108	Jam Nuts.....	112	Moroso Wires.....	81
Front Spoiler.....	180	Heat Barrier.....	101, 104	Jaz Fuel Cells.....	96-97	Motor Mt Adapter Plates.....	114
Fuel Additives.....	203-207	Heat Barrier Blanket.....	101	Jaz Seats.....	32	Motor Mount Bolts.....	108
Fuel Block Kits.....	92	Heat Shield.....	104	J-Bars.....	178, 181	Motor Mount Pads.....	114
Fuel Blocks.....	95, 196	Heat Sleeves.....	104	Jet Extensions.....	92	Motor Mounts.....	114, 116
Fuel Bowl Gasket.....	92	Heating Pads.....	54	Jet Nuts.....	125	Motor Oil.....	203, 206-207
Fuel Cell Caps.....	97	Heel Riser.....	116	Jets.....	92	Motor Plates.....	196
Fuel Cell Foam Kit.....	97	HEI Kits.....	72	Joe Gibbs Oil.....	203	Mr Gasket.....	111
Fuel Cell Mount.....	117	Heims.....	112	Jones Racing.....	64-65	MSD Ignition.....	69-83
		Helmet Bags.....	29	Jug Racks.....	150		
		Helmet Blowers.....	8				

MSD Spark Plug Wires	81-82	Pinion Centering Jigs	164	Radiators	60-61	Sandwich Filter Adapters	56
MSD Wires	82	Pinion Nuts	167	Radio Box	20-21	Scale Cart	157
Mud Covers	168	Pipe Plugs	48	Radios	20	Scale Pad Leveler	156-157
Mud Lock Rings	168	Pipe Thread Fittings	44-47, 49-53	Radius Plates	149	Scale Ramps	162
Mud Plugs	161, 169	Piston Ring File	153	Radius Rod Adapter	113	Scales	157
Mud Scrapers	150	Piston Ring Filter	106	Radius Rod Adapter Plate	181	Scanners	20-21
Mud-X Cleaner	205	Pit Extensions	161	Radius Rods	113	Schrader Valves	146
Muffler Cover	101	Pit Guns	160	Radius Tabs	114	Scoops	86
Muffler Heat Shield	104	Pit Socket	160	Ram Clutches	189	Screw In Breathers	54
Mufflers	102-103	Pitman Arms	173, 190	Ratchet Crimper	77	Scrub Bags	86
N		Pivot Kits	7, 15, 26	Rear Axle Spring Perch	115	Sealed Connectors	80
Neck Supports	9, 17, 28	Plastic	125	Rear Axles	179	Seat Belt Hardware	17
NecksGen	25	Pliers - Rivet	125	Rear Bumpers	180	Seat Belt Mt Backing Plates	114
Nerf Bar Grommet Seals	180	Plug Wire Sleeves	104	Rear Clips	180	Seat Belts	12-13, 17, 28
Nerfs	190	Plugs	48, 125, 155	Rear Coil Spring Seat	114	Seat Foam Kits	33
NGK Spark Plugs	81	Plumbing	44-53	Rear Cover Nuts	179, 194	Seat Mounts	32-33
Nitrogen Fill Tool	149	Plunge Slot Buttons	124	Rear End Cover Nuts	194	Seats	31-33
Nitrogen Filler Gauge	146	Poly Washers	97	Rear End Savers	194	Selector Switch	77
Nomex Underwear	9, 22, 28, 30	Positive Cam Lock Shifter	116	Rear End Yokes	176	Self Eject Buttons	121
Northeast Dirt Section	170-183	Positive Lock Shifter Cable	116	Rear Engine Plate	180	Serpentine Belts	65-66
Nut Kits	125	Power Steering Adapters	47	Rear Gear Covers	179	Serpentine Pulley Idler Kits	66
Nuts - Jam	112	Power Steering Brackets	66	Rear Gears	166	Serpentine Pulleys	66
Nuts	47, 112	Power Steer Fluids	64, 203, 206-207	Rear Hubs	174	Set Up Belts	190
Nylon Fans	63	Power Steering Hose	45	Rear Lower Spring Plates	115	Set Up Plates	164
Nylon Washers	120	Power Steering Pumps	65-66	Rear Main Seals	110-111	Set Up Stands	164, 180
O		Power Steering Reservoirs	61, 68	Rear Spindles	175	Setrab Oil Coolers	56
Octane Booster	207	Power Steering Tanks	66, 68	Recovery Tanks	61-62	Shaft Rockers	108
Oil Cooler Adapters	55	Power Valve Tester	152	Reducer Bushings	46, 126	Shafts	68
Oil Cooler Mounts	62	Power Valves	92	Reducers	47, 102	Shield Bags	15
Oil Coolers	56, 61	Pre Cleaners	85	Regulator Brackets	89	Shield Bags	29
Oil Filter Adapters	55, 57	Pre Filters	86	Regulators	94-95	Shield Cleaner	7, 14
Oil Filter Block Offs	55	Pressure Plate Bolt Kits	106	Reinforcing Plates	126	Shield Foam Kits	15
Oil Filter Cutter	156	Proporting Valves	137	Reinforcing Washers	126	Shields	19, 26
Oil Filter MOUNTS	55, 57	Pulley Installer Tool	65	Relays	40	Shift Light	79
Oil Filters	54, 57	Pulley Shim Kits	156	Release Bearings	189	Shifter	185
Oil Line Kits	61	Pulley Spacers	66	Release Hubs	66	Shifter Cables	117, 194
Oil Pan Drain Plugs	54	Pulleys	57, 65-66	Remote Caliper Brackets	175	Shifter Knob	165
Oil Pan Gaskets	54, 110-111	Pump Adapter	195	Reservoir Tanks	195	Shifter Stick	165
Oil Pan Inspection Plug Kits	54	Push Rod Length Checkers	152	Residual Check Valves	134	Shifters	188, 202
Oil Pans	55	Pushrod Length Checker	109	Retard Control	77	Shim Spacers	168
Oil Preheaters	54	Pushrods	109	Rev Control	70, 79	Shock Brackets	116
Oil Pressure Fittings	52, 57	Pyrometer	162-163	Rev Limiter	71	Shock Dynamometer	156
Oil Pressure Gauges	35	Q		Rev Limiter Switch Box	79	Shock Fluid	207
Oil Pump Belt Guides	57	QA1 Rod Ends	112	Ring & Pinion Install Kits	166-167	Shock Inflation	158
Oil Pump Bolts	107	Quad Lock Birdcage	174	Ring and Pinions	166-167, 183	Shock Inflation Tool	162
Oil Pump Driveshafts	55	Quad Lock Caliper Bkt	174	Ring Compressor	153	Shock Inflator	148, 162
Oil Pump Drives	55	Quad Lock Tubes	174	Ring Filer	106	Shock Oil	145
Oil Pump Driveshaft Kits	107	Quick Change Gear Trays	150	Ring Gear Bolt Kits	167	Shock Pistons	146
Oil Pump Primer	153	Quick Change Gears	177	Rivet Back Up Plate	124	Shock Protector	148
Oil Pump Primer Kits	153	Quick Change Pinion Mts	181	Rivet Gun	125	Shock Replacement Parts	145
Oil Pump Pulleys	57	Quick Change Rear Axles	179	Rivet Pliers	125	Shock Sliders	148, 172
Oil Pump Studs	107	Quick Change Rear End Assy	194	Rivets	125	Shock Tower Locks	148
Oil Rear Lube	205	Quick Ch Ring & Pinion	167, 179	Robic Watch	151	Shock Towers	180
Oil Stabilizer	205	Quick Change Spools	179	Rock Screens	61	Shocks	144-147
Oil Storage Cabinets	150	Quick Disconnects	66	Rocker Arm Stud Kits	108	Shockwears	144
Oil Tank Heaters	54	Quick Fill	99	Rocker Arms	108	Shoe Laces	11
Oil Tank Mounts	196	Quick Fill Cans	96	Rockers	108	Shoes	11, 16, 20, 23, 27, 30
Oil Tanks	54	Quick Fuel Carburetors	89	Rod Bolt Extensions	153	Should Supports	33
Oil Temperature Gauges	35	Quick Fuel Components	96	Rod Bolt Stretch Gauge	153	Shrouds	61-62
O'Rings	48, 130	Quick Pin Kits	190	Rod End Seals	119	Shut Offs	137, 139
Outerwears Pre Filters	86	Quick Pins	116	Rod Ends	112	Shuttle Gauge	149
Oval Head Buttons	120	Quick Release Hubs	134	Rod Guide Tool	156	Side Bars	180
Overflow Brackets	63	Quick Release	66	Roll Bar Padding	29	Side Bells	182, 179
Overflow Catch Cans	96	Quick Release Hubs	66	Roll Stop	134	Side Rub Rails	180
Overflow Check Valves	96	Quick Rel Muffler Clamps	196	Roller Assembly	174	Simpson	6-13
Overflow Tanks	58, 63	Quick Rel Steering Disconnects	195	Roller Lifters	109	Simpson Helmets	6-7
P		R		Roller Race Sets	105	Slave Cylinders	136
Painless Wires	40	Race Fans	63	Roller Rockers	108	Slip Yoke Assembly	194
Paint	101	Race Roller Timing Kits	105	Rotor Adapter	133	Slip Yokes	176, 188
Panel Spring Adjuster	121	Race Wax	203	Rotor Bolts	192	Smart Tube Axle Systems	174
Panel Springs	121	Raceceiver	20	Rotor Hats	133	Smart Tubes	174
Panefast	120-124	Racequip	20	Rotor Spacer	168-169	Snips	125
Panefast Tools	123-124	Racer Tapes	151	Rotors	76, 131-133, 139	Sockets	44, 49
Panhard Bar Brackets	119	Racing Electronics	21	Royal Purple Oils	206	Socks	9, 22, 28, 30
Panhard Bar Mounts	178	Rack and Pinion	68	RPM Activated Switch	79	Soft Touch Rev Control	79
Panhard Bracket	172	Radial Mount	128	RPM Chips	80	Solid Transmission Mts	114
Panhard Mounts	178	Radial Mount Brackets	174	RPM Module	79	Spacer Kits	115
Panhard Slider	172	Radiator Air Combs	61	RPM Module Kits	71	Spacer Reducers	126
Panhard's	181	Radiator Caps	62	RPM Module Selectors	79	Spacers	93
Parachutes	17	Radiator Fittings	60	Rub Rails	180	Spanner Wrench	146
PCV Grommet	55	Radiator Honeycombs	62, 196	Rubber Hose	45	Spare Tire Holders	150
Pedal Assembly	136	Radiator Hose Fillers	62	S		Spark Guard	80
Performance Friction	139	Radiator Hoses	62	Safety Glasses	164	Spark Plug Gap Tool	156
Perma-Loc	108	Radiator Mounts	61-63	Safety Shields	202	Spark Plug Indexer	83
Pin Crimp Dies	77	Radiator Shaker Screens	62	Safety Wire	149	Spark Plug Indexing	152
Pin Extraction Tool	80	Radiator Water Restrictors	58	Safety Wire Drill Jig	149	Spark Plug Indexing Tool	156
				Safety Wire Pliers	149	Spark Plug Index Washers	152

Spark Plug Shield.....	104	Tail Tank Cooler.....	192	Torque Arm Sliders.....	178	Vave Core Tool.....	160
Spark Plug Wire Synch Kits.....	79	Tank Brackets.....	196	Torque Arms.....	178	V-Belt Pulley.....	56
Spark Plugs.....	81	Tape Measure.....	160	Torque Ball Housing Studs.....	194	V-Belts.....	63
Spark Pug Shield.....	83	Taper Reamer.....	164	Torque Ball Safety Blanket.....	194	Vent Filters.....	85
Spectro Trans Fluid.....	185	Tapered Ring Compress.....	107, 153	Torque Converter Bolts.....	106	Vent Kits.....	55
Speed Wax.....	205	Tapered Spacer Kits.....	93	Torque Tube Nut Kits.....	194	Vent Tanks.....	54
Spindle Checker Tools.....	117	Tapered Spacers.....	126	Torque Tube Stud Kits.....	194	Vent Tube Reduction Valves.....	90
Spindle Gauge.....	115	Tapes.....	151	Torque Tubes.....	194	Vibration Mounts.....	70
Spindle Nut Socket.....	161	Tear Off Posts.....	18	Torsion Arm Roller Adj Tool.....	178	Viton Inlet Needles.....	92
Spindle Nut Washer Assy.....	171	Tear Offs.....	8	Torsion Arms.....	178, 190	W	
Spindle Nuts.....	170-171	Tee Pipe Adapters.....	46	Torsion Bar Bushings.....	173, 193	Warning Lights.....	36, 39
Spindle Savers.....	115	Tel Tac.....	34	Torsion Bar Plug Kit.....	117	Washer Body Bolts.....	117
Spindle Wrench.....	192	Temp Adapters.....	37	Torsion Bar Rate Checker.....	173	Water Filler Necks.....	62
Spindles.....	170-171, 192	Terminal Blocks.....	37	Torsion Bar Reamer.....	193	Water Necks.....	59
Spline Grease.....	203	Terminals.....	38	Torsion Bar Roller.....	174	Water Outlet Gaskets.....	110-111
Splined Couplers.....	68	Terminals Kits.....	40	Torsion Bars.....	173, 193	Water Outlet Restrictor Kits.....	62
Splined Rear Wheel Ctrs.....	194	Thermal Mat.....	101	Torsion Bearings.....	173	Water Pump Relays.....	40
Spoiler Brackets.....	125	Thermo Sleeves.....	104	Torsion Stops.....	173, 193	Water Pump Shim Kits.....	58
Spoiler Mounts.....	180	Thermo Tec.....	101, 104	Towels.....	164	Water Pump Spacer Kits.....	58
Spoilers.....	180	Thermostat Gaskets.....	110-111	Track Mats.....	150	Water Pump Spacers.....	65
Spring Adapters.....	141, 143	Thermostat Housing Banks.....	62	Traction Grabber Grinder.....	160	Water Pump Spacers.....	58-59
Spring Bags.....	148	Thermostat Housing Bolts.....	106	Traction Tools.....	161	Water Temp Gauges.....	35
Spring Cups.....	115	Thermostat Housing Space.....	62	Trailer Door Cabinets.....	150	Wax.....	203, 205
Spring Plates.....	115	Thread Chaser.....	156	Trailer Ramps.....	162	Weather Seal.....	205
Spring Rods.....	179	Thread Plug Kits.....	117	Trailing Arm Bracket.....	119	Weathertight Sealed Connect.....	80
Spring Spacers.....	115, 141, 143	Throttle Adjuster.....	92	Transmission.....	176, 185-188, 193	Weight.....	117
Spring Steel Punches.....	164	Throttle Arms.....	195	Transmission Coolers.....	56	Weight Jack Bolt Sleeves.....	115
Springs - Panel.....	121	Throttle Bell Cranks.....	117	Transmission Fluid.....	185	Weight Jack Bolts.....	115
Springs.....	141-143	Throttle Body Gasket.....	92	Transmission Fuel Additive.....	204	Weight Jack Plates.....	115
Sprint Car Section.....	190-197	Throttle Cable Bracket.....	92	Trans Kickdown Stud.....	92	Weld Fittings.....	52
Sprint Car Tank Brackets.....	54	Throttle Cable Mounting Kit.....	100	Transmission Mounts.....	114, 116	Weld Plates.....	122-123, 127
Sprint Wash Plug Sets.....	117	Throttle Cables.....	117	Transmission Pan Bolt Kits.....	106	Weld Plates w/Spring.....	127
Sq Drive Balancer Bolts.....	105	Throttle Linkage.....	100	Transmission Pan Bolt Kits.....	106	Weld Wheels.....	168-169
Stacker Radiators.....	61	Throttle Linkage.....	100	Transmission Pans.....	202	Wheel Adapter.....	161
Stagger Gauge.....	149	Throttle Linkage Kits.....	195	Trans Rebuild Parts.....	185-187	Wheel Centers.....	194
Stainless St Brake Lines.....	140	Throttle Pedal Assembly.....	117	Trans Safety Shields.....	202	Wheel Covers.....	169
Stainless Steel Valves.....	108	Throttle Return Spring Kit.....	100	Transmission Supports.....	116	Wheel Cribs.....	162
Starter Button.....	38-39	Throttle Return Springs.....	100	Trans Temp Gauges.....	35	Wheel Dolies.....	163
Starter Heat Shield.....	39, 104	Throttle Sponge.....	117	Transponders.....	8	Wheel Spacers.....	66, 161, 168
Starter Ring Gears.....	188	Throttle Stud.....	92	Tread Depth Gauge.....	162	Wheel Studs.....	161
Starter Savers.....	77	Thrust Bearing Kits.....	141	Tri-Y Headers.....	102-103	Wheel Well Tubs.....	180
Starter Shims.....	188	Tie Down Hangers.....	150	Tube Cutters.....	149	Wheels.....	168-169
Starter Solenoids.....	38	Tie Downs.....	151, 164	Tubing.....	102	Wide 5 Hubs.....	134, 175
Starters.....	38, 176, 184, 188	Tie Rod Ends.....	119	Tubing Adapters.....	52	Wide 5 Tubes.....	174
Steel Fans.....	63	Tie Rod Sockets.....	161	Tubing Notchers.....	164	Wide 5 Wheels.....	168
Steering Arms.....	170, 192	Tie Wraps.....	29	Tubular Throttle.....	195	Wide Roller Kits.....	178
Steering Box Mounts.....	66, 173, 195	Timing Belt Set.....	105	Turbo Insulating Kit.....	104	Wilwood.....	128-137
Steering Boxes.....	68, 173	Timing Chains.....	105	Turn Plates.....	159	Winches.....	151
Steering Column Bkts.....	68	Timing Clipboard.....	151	Turnouts.....	102	Windage Trays.....	54
Steering Gear Locators.....	195	Timing Control.....	77	U		Window Net Mounts.....	33
Steering Hubs.....	66	Timing Cover.....	105	U-Bolt Pads.....	115	Window Nets.....	9, 29
Steering Joints.....	68	Timing Covers.....	196	U-Bolts.....	188	Window Screens.....	180
Steering Mounts.....	173	Timing Gear Covers.....	196	U-Joint Caps.....	176	Wing Nuts.....	55
Steering Pads.....	67	Timing Gear Drive.....	105	U-Joints.....	176, 188	Wing Rams.....	193
Steering Quick Disc.....	66, 195	Timing Indicator.....	83	Underwear.....	22	Winged Buttons.....	121
Steering Quick Release.....	66	Timing Lights.....	78, 83, 152, 159	Universal Flat Tabs.....	114	Wire Boots.....	82
Steering Shaft Tubing.....	68	Timing Pointers.....	106	Upper A-Arm Brackets.....	115	Wire Looms.....	83
Steering Shafts.....	68	Timing Tapes.....	76, 105	Upper A-Arm Mounts.....	117	Wire Sleeves.....	83
Steering Wheel Ext.....	66	Tire Bead Breaker.....	160	Upper Control Arm Shims.....	115	Wire Terminals.....	82
Steering Wheel Hooks.....	66	Tire Deflator.....	169	Upper Radiator Mounts.....	63	Wires.....	39
Steering Wheel Spacers.....	66	Tire Durometer.....	158	Upper Spring Plates.....	115	Wires.....	74
Steering Wheels.....	67	Tire Gauge.....	158	Utility Jugs.....	150	Wiring Harness.....	40, 70
Stewart Water Pumps.....	58	Tire Groover.....	160	V		Wiring Kits.....	40
Stop Watches.....	151	Tire Inflator.....	163	Vacuum Advance Stop Pl.....	74	Wiring Sleeves.....	104
Storage Bags.....	153	Tire Marker.....	160	Vacuum Gauges.....	35	Wix Oil Filters.....	57
Storage Containers.....	106	Tire Prep Cart.....	157	Vacuum Pressure Gauge.....	154	Wrap Around Gussets.....	117
Stripper Crimper.....	77	Tire Prep Mount.....	161	Vacuum Pump Regulator.....	56	Wrench - Fasteners.....	124
Stub Stacks.....	93	Tire Prep Stand.....	161	Vacuum Pumps.....	56	Wrenches.....	49, 165
Stud Extracting Tool.....	153	Tire Pressure Relief.....	161	Vacuum Regulator.....	54	X	
Stud Girdles.....	108	Tire Pressure Gauge.....	163	Valve Cover Breathers.....	55, 85, 165	XS Power Batteries.....	42
Stud Shafts.....	194	Tire Purge Tool.....	160	Valve Cover Gaskets.....	55, 110-111	Y	
Studs.....	101	Tire Pyrometer.....	162	Valve Cover Stud Kits.....	55	Y-Blocks.....	95
Suit Cleaners.....	10	Tire Rack.....	150	Valve Cover Studs.....	55	Yokes.....	167, 176, 182, 188
Suits.....	10, 16, 20, 22, 27, 30	Tire Roll Out Fixture.....	161	Valve Covers.....	55	Z	
Suspension Limiter.....	181	Tire Roller.....	158, 175	Valve Kits.....	145	Zerks.....	168
Sway Bar Arms.....	173	Tire Sander.....	160	Valve Lash Adjusting Tool.....	152		
Sway Bar Mount.....	173	Tire Sander Holder.....	161	Valve Lash Wrench.....	152		
Switch Fused Panel.....	40	Tire Scribe.....	149	Valve Seal Installer.....	152		
Switch Panels.....	36-37	Tire Siper.....	157, 160	Valve Seat Pressure Tester.....	154		
Switches.....	38-39	Tire Spoons.....	160	Valve Shim Kits.....	146		
SynFilm.....	206	Tire Tools.....	160	Valve Spring Compressor.....	154, 156		
Syphon Pump.....	150	Tire Treatment.....	204-205	Valve Spring Hgt Micrometers.....	152		
T		Tire Treatments.....	161	Valve Spring Pressure Tester.....	154		
Tach Splitter.....	69	Tire Treliefs.....	161	Valve Springs.....	109		
Tachometers.....	34	Toe Gauge.....	149, 164	Valve Stems.....	168		
Tail Pipe Header Bolts.....	103	Toe Plates.....	159, 164	Valve Train Tray.....	152		
Tail Pipe Kits.....	103	Tool Tray.....	150	Valves.....	92, 108		
		Torque Arm Biscuit Assy.....	178				
		Torque Arm Hoops.....	178				
		Torque Arm Plates.....	178, 181				



Mailing: P.O. Box 550 • Florida, NY 10921
 Shipping: 38 Meadow Rd • Florida, NY 10921
 Order #: 877-372-2348 • Tech #: 845-651-7389
 Fax #: 845-651-1200 • www.behrents.com

PRSR STD
 U.S. POSTAGE
 PAID
 BEHRENT'S
 SPEED
 CENTER

Scan here to Shop
 our Mobile Website



Be sure to "LIKE" us on Facebook and "FOLLOW" us on Twitter & Instagram.



Volume XIX



Photo by Bob Armbruster

